Seismic Provisions for Structural Steel Buildings (1997) Supplement No. 2

November 10, 2000

Supersedes Supplement No. 1 to the AISC *Seismic Provisions for
Structural Steel Buildings*, dated February 15, 1999

Prepared by the American Institute of Steel Construction, Inc.
under the direction of the AISC Committee on Specifications and
approved by the AISC Board of Directors



Seismic Provisions for Structural Steel Buildings (1997) Supplement No. 2

November 10, 2000

1. Part I, Glossary

Delete the definition of *Inelastic Rotation of Beam-to-Column Connection*.

Add the following definitions:

Interstory Drift Angle. Interstory displacement divided by story height, radians.

Zipper Column. A vertical (or nearly vertical) strut connecting the brace-to-beam intersection of an inverted-V-braced frame at one level to the brace-to-beam intersection at another level. See Figure C-13.4 (b)."

Change definition of *Reduced Beam Section* as follows:

"A ~~ductile~~ reduction in cross-section . . . <remainder unchanged>"

2. Part I, Section 2

Change this section as follows:

...

American Society of Civil Engineers
ASCE 7-95~~98~~

American Society for Testing and Materials

ASTM A6-96~~b98~~

ASTM A500-93~~99~~

ASTM A673-95

ASTM A36-96~~97a~~

ASTM A501-93~~99~~

ASTM A913-95~~a97~~

ASTM A53-96~~99b~~

ASTM A572-94~~e99~~

ASTM A992-98

ASTM A283-93a

ASTM A588-94~~97a~~

American Welding Society

AWS D1.1-96~~D1.1:2000~~

....

3. Part I, Section 6.1

Add ASTM A992 to the list of material specifications that are approved for use in the Seismic Force Resisting System.

4. Part I, Section 6.2

Change this section as follows:

“When required in these Provisions, the required strength of a connection or related member shall be determined from the Expected Yield Strength F_{ye} of the connected member, where

$$F_{ye} = R_y F_y \quad (6-1)$$

F_y is the specified minimum yield strength of the grade of steel to be used. For rolled shapes and bars, R_y shall be as shown in Table I-6-1 taken as 1.5 for ASTM A36 and 1.3 for A572 Grade 42. For rolled shapes and bars of other grades of steel and for plates, R_y shall be taken as 1.1. Other values of R_y are permitted to be used if the value of F_{ye} is determined by testing that is conducted in accordance with the requirements for the specified grade of steel.

TABLE I-6-1
 R_y Values for Different Member Types

Application	R_y
Plates and all other products	1.1
Hot-rolled structural shapes and bars	
ASTM A36	1.5
A572 Grade 42	1.3
All other grades	1.1
Hollow Structural Sections	
ASTM A500, A501, A618 and A847	1.3
Steel Pipe	
ASTM A53	1.4

When both the required strength and the design strength calculations are made for the same member or connecting element, it is permitted to apply R_y to F_y in the determination of the design strength.”

5. Part I, Section 6.3

Change this section as follows:

“When they are used as members in the Seismic Force Resisting System, ASTM A6 Groups 3, 4, and 5 shapes with flanges 1½ in. thick and thicker, ~~ASTM A6 Groups 4 and 5 shapes~~, and plates that are ≥ 1½-in. thick or thicker in built-up cross-sections shall have a minimum Charpy V-Notch (CVN) toughness of 20 ft-lbs at 70 degrees F, determined as specified in LRFD Specification Section A3.1c.”

6. Part I, Section 7.3b

Change language as follows:

“All ~~complete joint penetration groove~~ welds used in primary members and connections in the Seismic Force Resisting System shall be made with a filler metal that has a minimum ~~CVN~~ Charpy V-notch toughness of 20 ft-lbs at minus 20 degrees F, as determined by AWS classification or manufacturer certification. This requirement . . . <remainder unchanged>”

7. Part I, Section 7.3c

Change this section as follows:

“For members and connections that are part of the Seismic Force Resisting System, discontinuities located within a plastic hinging zone as defined in Section 7.4a, created by errors or by fabrication or erection operations, such as tack welds, erection aids, air-arc gouging, and thermal ~~flame~~ cutting, shall be repaired as required by the Engineer of Record.”

8. Part I, Section 7.4

Add the following new section:

“7.4. Other Connections

7.4a. Welded shear studs shall not be placed on beam flanges within the zones of expected plastic hinging. The length of a plastic hinging zone shall be defined as one-half of the depth of the beam on either side of the theoretical hinge point. Decking arc-spot welds as required to secure decking shall be permitted. Decking attachments that penetrate the beam flanges shall not be used in the hinging zone.

- 7.4b.** Welded, bolted, screwed, or shot-in attachments for perimeter edge angles, exterior facades, partitions, duct work, piping, or other construction shall not be placed within the expected zone of plastic hinging, as defined in Section 7.4a, or of other members of the *Seismic Force Resisting System* which are expected to undergo plastic hinging. Outside the defined hinge area, calculations, based on the expected moment at the plastic hinge, shall be made to demonstrate the adequacy of the member net section when connectors which penetrate the member are used.

Exception: Welded shear studs and other connections are permitted where they have been included in the connection tests used to qualify the connection.”

9. Part I, Section 8.3

Add the following new section:

- “8.3c.** Column splices in Special Moment Frames shall be located as described in Section 8.3a, and shall have a nominal flexural strength that is at least equal to the nominal flexural strength of the smaller column. Where groove welds are used to make the splice, they shall be complete-joint-penetration groove welds. Weld backing need not be removed unless required by the Engineer of Record. The design shear strength of the connection shall be equal to or greater than the required shear strength calculated using the expected yield moments that can be developed at each end of the column.

Exception: The design strength of the column splice need not exceed the required strength as determined by inelastic analyses in which appropriate stress concentration factors have been considered for the type of connection being used.”

10. Part I, Section 9.2a

Change the first sentence as follows:

“The design of all beam-to-column joints and connections used in the Seismic Force Resisting System shall be based upon qualifying

cyclic test results in accordance with Appendix S that demonstrate an interstory drift angle of at least 0.04 radians inelastic rotation of at least 0.03 radians.”

Add the following sentence at the end of the last paragraph:

“Columns and connection elements with a tested yield strength that is more than 15 percent above or below F_{ye} shall not be used in qualification testing.”

11. Part I, Section 9.3a

Change this section as follows:

“Shear Strength: The required ~~thickness shear strength~~ R_u of the panel zone shall be determined in accordance with the method used in proportioning the panel zone of the tested connection ~~by applying Load Combinations 4-1 and 4-2 to the connected beam or beams in the plane of the frame at the column. R_u need not exceed the shear force determined from 0.8 times $\Sigma R_y M_p$ of the beams framing to the column flanges at the connection.~~ As a minimum, the required shear strength R_u of the panel zone shall be determined from the summation of the moments at the column faces as determined by projecting the expected moments at the plastic hinge points to the column faces. The design shear strength $\phi_v R_v$ of the panel zone shall be determined using $\phi_v = 0.75$ 1.0. When $P_u \leq 0.75 P_y$,” [Remainder unchanged].

12. Part I, Section 9.4b

Change this section as follows:

“Width-Thickness Ratios: Beams shall comply with λ_p in Table I-9-1. When the ratio in Equation 9-3 is less than or equal to 2.0 ~~1.25~~, columns shall comply with λ_p in Table I-9-1. Otherwise, columns shall comply with λ_p in LRFD Specification Table B5.1.”

13. Part I, Section 9.6

Change definition of ΣM^*_{pb} as follows:

“The sum of the moment(s) in the beam(s) at the intersection of the beam and column centerlines. ΣM^*_{pb} is determined by summing the projections of the expected beam flexural strength(s) . . .”

14. Part I, Section 9.7a.1

Change Section 9.7a.1. as follows:

1. Column flanges at beam-to-column connections require lateral support only at the level of the top flanges of the beams when a column is shown to remain elastic outside of the panel-zone. under either of the following conditions: It shall be permitted to assume that the column remains elastic when the ratio calculated using Equation 9-3 is greater than 2.
- a. ~~The ratio calculated using Equation 9-3 is greater than 1.25.~~
 b. ~~The column remains elastic under Load Combination 4-1.~~

15. Part I, Sections 10 & 11

Replace Sections 10 and 11 with the following:

10. INTERMEDIATE MOMENT FRAMES (IMF)

10.1. Scope

Intermediate Moment Frames (IMF) are expected to withstand limited inelastic deformations in their members and connections when subjected to the forces resulting from the motions of the Design Earthquake. IMF shall meet the requirements in this Section.

10.2. Beam-to-Column Joints and Connections

10.2a. The design of all beam-to-column joints and connections used in the Seismic Force Resisting System shall be based upon qualifying cyclic test results in accordance with Appendix S that demonstrate an interstory drift angle of at least 0.02 radians. Qualifying cyclic test results shall consist of at least two cyclic tests and shall meet the requirements in Section 9.2a.

10.2b. Beam-to-column connection testing shall demonstrate a flexural strength, determined at the column face, that is at least equal to the nominal plastic moment of the beam M_p at the required inelastic rotation (see Appendix S), except as follows:

1. When beam local buckling rather than beam yielding limits the flexural strength of the beam, or when connections incorporating a Reduced Beam Section are used, the flexural strength shall be taken as $0.8M_p$ of the tested beam.
2. Connections that accommodate the required rotations within the connection elements and

maintain the design strength as specified are permitted, provided it can be demonstrated by rational analysis that any additional drift due to connection deformation can be accommodated by the building. Such rational analysis shall include the effects of overall frame stability including second order effects.

3. The required shear strength V_u of a beam-to-column connection shall be determined using the load combination $1.2D + 0.5L + 0.2S$ plus the shear resulting from the application of a moment of magnitude equal to $1.1R_yF_yZ$ in the opposite sense on each end of the beam. Alternatively, a lesser value of V_u is permitted if justified by rational analysis. The required shear strength need not exceed the shear resulting from Load Combination 4-1.

10.3. Continuity Plates

Continuity plates shall be provided to be consistent with the tested connection.

11. ORDINARY MOMENT FRAMES (OMF)

11.1. Scope

Ordinary Moment Frames (OMF) are expected to withstand minimal inelastic deformations in their members and connections when subjected to the forces resulting from the motions of the Design Earthquake. OMF shall meet the requirements in this Section.

11.2. Beam-to-Column Joints and Connections

11.2a. Beam-to-column connections shall be made with welds and/or high-strength bolts. Connections are permitted to be FR or PR moment connections as follows:

1. FR moment connections that are part of the Seismic Force Resisting System shall be designed for a required flexural strength M_u that is at least equal to $1.1R_yM_p$ of the beam or girder or the maximum moment that can be delivered by the system, whichever is less. For connections with welded flange joints, weld backing and weld tabs shall be removed except that the top-flange backing is permitted to

remain in place provided that it is attached to the column flange by a continuous fillet weld on the edge below the complete-joint-penetration groove weld. After removal of weld backing, the surface shall be repaired and a contouring fillet weld added. Weld tabs shall be removed and the surface finished flush and smooth. Single-sided partial-joint-penetration groove welds and single-sided fillet welds shall not be used to resist tensile forces in the connections. Double-sided partial-joint-penetration groove welds and double-sided fillet welds that resist tensile forces in the connections shall be designed to resist a required force of $1.1R_yF_yA_g$ of the connected element or part.

2. PR moment connections are permitted when the following requirements are met:
 - a. Such connections shall provide for the design strength as specified in Section 11.2a.1.
 - b. The nominal flexural strength of the connection shall be no less than 50 percent of M_p of the connected beam or column, whichever is less.
 - c. The stiffness and strength of the PR moment connections shall be considered in the design, including the effect on overall frame stability.

11.2b. For FR moment connections, the required shear strength V_u of a beam-to-column connection shall be determined using the load combination $1.2D + 0.5L + 0.2S$ plus the shear resulting from the application of $1.1R_yF_yZ$ in the opposite sense on each end of the beam. Alternatively, a lesser value of V_u is permitted if justified by rational analysis. For PR moment connections, V_u shall be determined from the load combination above plus the shear resulting from the maximum end moment that the PR moment connections are capable of resisting.

11.3. Continuity Plates

When FR moment connections are made by means of welds of beam flanges or beam-flange connection plates directly to column flanges, continuity plates shall be provided to transmit beam flange forces to the column web or webs. Such plates shall have a minimum thickness equal to that of the beam flange or beam-flange connection plate. The welded joints of the continuity plates to the column flanges shall be made with either complete-joint-penetration groove welds, two-sided partial-joint-penetration groove welds combined with reinforcing fillet welds, or two-sided fillet welds and shall provide a design strength that is at least equal to the design strength of the contact area of the plate with the column flange. The welded joints of the continuity plates to the column web shall have a design shear strength that is at least equal to the lesser of the following:

- a. The sum of the design strengths at the connections of the continuity plate to the column flanges.
- b. The design shear strength of the contact area of the plate with the column web.
- c. The weld design strength that develops the design shear strength of the column panel-zone.
- d. The actual force transmitted by the stiffener.

Continuity plates are not required if tested connections demonstrate that the intended inelastic rotation can be achieved without their use.

16. Part I, Section 13.2d

Change language as follows:

“Width-thickness Ratios: Width-thickness ratios of stiffened and unstiffened compression elements of braces shall meet the compactness requirements in LRFD Specification Table B5.1 (i.e., $\lambda < \lambda_p$) and the following requirements:

1. ~~Braced shall be compact (i.e., $\lambda < \lambda_p$).~~ The width-thickness ratio of angles shall not exceed $52 / \sqrt{F_y}$.
2. I-shaped members and channels used as braces shall comply with λ_p in Table I-9-1.
3. Round HSS shall have... <remainder unchanged>”

17. Part I, Sections 14.2 through 14.5

Delete Sections 14.2 through 14.5 and replace with the following:

“14.2 Strength

The required strength of the members and connections, other than brace connections, in OCBFs shall be based upon Load Combinations 4-1 and 4-2. The design strength of brace connections shall equal or exceed the expected tensile strength of the brace, determined as $R_y F_y A_g$. Braces with Kl/r greater than $720 / \sqrt{F_y}$ shall not be used in V or inverted-V configurations.”

18. Part I, Section 16

Add the following sentence at the end of the Section:

“When welds from web doubler plates or continuity plates occur in the ‘k-area’ of rolled steel columns, the ‘k-area’ adjacent to the welds shall be inspected after fabrication, as required by the Engineer of Record, using approved nondestructive methods conforming to AWS D1.1.”

19. Appendix S, Section S2

Replace this section with the following:

“S2. SYMBOLS

The number in parenthesis after the definition of a symbol refers to the Section number in which the symbol is first used.

θ	Interstory drift angle (S6)
γ	Link rotation angle (S6)”

20. Appendix S, Section S3

Add the following definitions:

“*Complete Loading Cycle*. A cycle of rotation taken from zero force to zero force, including one positive and one negative peak.”

“*Interstory Drift Angle*. Interstory displacement divided by story height, radians.”

Replace the definition of *Inelastic Rotation* with the following:

“*Inelastic Rotation*. The permanent or plastic portion of the rotation angle between a beam and the column or between a Link and the column of the Test Specimen, measured in radians. The

Inelastic Rotation shall be computed based on an analysis of Test Specimen deformations. Sources of inelastic rotation include yielding of members, yielding of connection elements and connectors, and slip between members and connection elements. For beam-to-column moment connections in Moment Frames, inelastic rotation shall be computed based upon the assumption that inelastic action is concentrated at a single point located at the intersection of the centerline of the beam with the centerline of the column. For link-to-column connections in Eccentrically Braced Frames, inelastic rotation shall be computed based upon the assumption that inelastic action is concentrated at a single point located at the intersection of the centerline of the link with the face of the column.”

21. Appendix S, Section S5.5

Change #2 as follows:

“2. The yield stress of the beam shall not be more than 15 percent below F_{ye} for the grade of steel to be used for the corresponding elements of the Prototype. Columns and connection elements with a tested yield stress shall not be more than 15 percent above or below F_{ye} for the grade of steel to be used for the corresponding elements of the Prototype. F_{ye} shall be determined in accordance with Section 6.2.”

22. Appendix S, Section S6.1

Replace this section with the following:

“S6.1. General Requirements

The Test Specimen shall be subjected to cyclic loads according to the requirements prescribed in Section S6.2 for beam-to-column moment connections in Moment Frames, and according to the requirements prescribed in Section S6.3 for link-to-column connections in Eccentrically Braced Frames.

Loading sequences other than those specified in Sections S6.2 and S6.3 may be used when they are demonstrated to be of equivalent or greater severity.”

23. Appendix S, Section S6.2

Replace this section with the following:

“S6.2 Loading Sequence for Beam-to-Column Moment Connections

Qualifying cyclic tests of beam-to-column moment connections in Moment Frames shall be conducted by controlling the interstory drift angle, θ , imposed on the Test Specimen, as follows:

- a. 6 cycles at $\theta = 0.00375$ rad.
- b. 6 cycles at $\theta = 0.005$ rad.
- c. 6 cycles at $\theta = 0.0075$ rad.
- d. 4 cycles at $\theta = 0.01$ rad.
- e. 2 cycles at $\theta = 0.015$ rad.
- f. 2 cycles at $\theta = 0.02$ rad.
- g. 2 cycles at $\theta = 0.03$ rad.

Continue loading at increments of $\theta = 0.01$ rad., with two cycles of loading at each step.”

24. Appendix S, Section S6.3

Replace this section with the following:

“S6.3 Loading Sequence for Link-to-Column Connections

Qualifying cyclic tests of link-to-column moment connections in Eccentrically Braced Frames shall be conducted by controlling the link rotation angle, γ , imposed on the Test Specimen, as follows:

- a. 3 cycles at $\gamma = 0.0025$ rad.
- b. 3 cycles at $\gamma = 0.005$ rad.
- c. 3 cycles at $\gamma = 0.01$ rad.
- d. 2 cycles at $\gamma = 0.02$ rad.
- e. 2 cycles at $\gamma = 0.03$ rad.

Continue loading at increments of $\gamma = 0.01$ rad., with two cycles of loading at each step.”

25. Appendix S, Section S9

Change Item No. 6. as follows:

- “6. A plot of beam moment versus ~~total Inelastic Rotation~~ interstory drift angle for beam-to-column moment connections; or a plot of link shear force versus link rotation”

angle for link-to-column connections. For beam-to-column connections, the beam moment and the ~~total Inelastic Rotation~~ interstory drift angle shall be computed with respect to the ~~face~~ centerline of the column. ”

Change Item No. 7 as follows:

“7. The interstory drift angle and the total Inelastic Rotation developed by the Test Specimen. <Remainder unchanged>”

26. Appendix S, Section S10

Change this section as follows:

“For each connection used in the actual frame, at least two tests are required for each connection in which the Essential Variables, as listed in Section S4, remain within the required limits. Both tests shall satisfy the criteria stipulated in Sections ~~8.5~~, 9.2, 10.2, or 15.4, as applicable. In order to satisfy ~~Inelastic Rotation~~ interstory drift angle requirements, each Test Specimen shall sustain the required ~~rotation~~ interstory drift angle for at least one complete loading cycle.”

27. Part II, Section 6.5c

Change Equation 6-3 as follows:

$$1.40b\sqrt{F_y/E_s} - b\sqrt{F_y/(2E_s)} \quad (6-3)$$

28. Part II, Section 13.4

Change Part II, Section 13.4 as follows:

“13.4. Braces

Structural steel braces shall meet the requirements for ~~OCBFCB~~ in Part I Section 4413. Composite braces shall meet the requirements for composite columns in Section 13.2.”

29. Part II, Section 13.5

Change Part II, Section 13.5 as follows:

“Bracing connections shall meet the requirements in Section 7 and Part I Section 4413.”

30. Commentary Part I, Section C1

Add the following paragraph:

“It should be noted that these provisions were developed specifically for buildings. The provisions, therefore, may not be applicable, in whole or in part, to non-building structures. Extrapolation of their use to non-building structures should be done with due consideration of the inherent differences between the response characteristics of buildings and non-building structures.”

31. Commentary Part I, Section C4

Replace all references to “1997 NEHRP Provisions (FEMA, 1997A)” with “2000 NEHRP Provisions (FEMA, 2000e)”.

In Table I-C4-1 replace the values given for Intermediate Moment Frames (IMF) and Ordinary Moment Frames (OMF) with the following:

BASIC STRUCTURAL SYSTEM AND SEISMIC FORCE RESISTING SYSTEM	<i>R</i>	<i>C_d</i>
Intermediate Moment Frames (IMF)	4.5	4
Ordinary Moment Frames (OMF)	3.5	3

32. Commentary Part I, Section C6.2

Add the following to the end of this section:

“While ASTM A709 is primarily used in the design and construction of bridges, it could also be used in building construction. Written as an umbrella specification, its grades are essentially the equivalent of other approved ASTM specifications. For example, ASTM A709 grade 50 is essentially ASTM A572 grade 50 and ASTM A709 grade 50W is essentially ASTM A588 grade 50. Thus, if used, ASTM A709 material should be treated as would the corresponding approved ASTM material grade.”

33. Commentary Part I, Section C6.3

Change Item (3) in the first paragraph as follows:

“... (3) plate elements with thickness greater than or equal to $\underline{2} \frac{1}{2}$ in. that are part of the Seismic Force Resisting System, such as the flanges of built-up girders.”

34. Commentary Part I, Section C7.3

Change the first sentence of the second paragraph of this section as follows:

“For all welds used in primary members and connections in the Seismic Force Resisting System, weld metal notch toughness is required in these Provisions.”

Add the following sentence to the end of the second paragraph:

“These weld toughness requirements are not intended to apply to ERW and SAW welding processes used in the production of HSS (ASTM A500) and pipe sections (ASTM A53).”

Add the following sentence to the end of the last paragraph of this section:

“The Engineer of Record should refer to AWS D1.1 for guidance in establishing the acceptance criteria for repair of discontinuities. Outside the plastic hinge regions, AWS D1.1 requirements for repair of discontinuities should be applied.”

35. **Commentary Part I, Section C7.4**

Add the following new commentary Section C7.4:

“**C7.4 Other Connections**

The FEMA/SAC testing has demonstrated the sensitivity of regions undergoing large inelastic strains to discontinuities caused by welding, rapid change of section, penetrations, or construction caused flaws. For this reason, operations that cause discontinuities are prohibited in the critical hinging region. Areas where critical hinging is expected include moment frame hinging zones as defined, link beams of EBFs, the ends and the center of SCBF braces, etc. It should be noted that yield level strains are not strictly limited to the plastic hinge zones (beam-column joint region for coverplate or RBS connections, e.g.). Caution should also be exercised in creating discontinuities in these regions as well.”

36. **Commentary Part I, Section C8.3**

Replace Commentary Section C8.3 with the following:

“**C8.3 Column Splices**

Inelastic analyses conducted as part of the FEMA/SAC program have demonstrated that the common assumption that column flexural stresses in the mid-height of moment

frame columns are low is not necessarily true. Bending moments equaling, or exceeding, the yield moment of the column are possible at column splices, even when the splices are located as required by Section 8.3a. Accordingly, the requirement is given that the nominal flexural strength of the splice should equal or exceed the nominal flexural strength of the smaller column. It is not necessary to apply over-strength factors and ϕ factors to the requirement, since it is a comparison of relative member nominal strengths.

The exception is provided to allow for cases where the Engineer of Record can demonstrate that the largest demands that can occur at column splices are below the yield level. Inelastic dynamic analyses are required to justify using this exception. In these cases, the use of welded joints other than complete-joint-penetration groove welds may be used, provided that stress concentration factors (e.g. estimated using a fracture mechanics approach) generated by the proposed joint configuration are taken into account.”

37. Commentary Part I, Section C9.2a

Add the following:

“Limitations are placed on permissible differences between the tested yield strength and F_{ye} for beams, columns and connection elements. It is not intended that these limitations be applied retroactively to the existing database of qualification tests. Rather, these requirements are intended to apply for use in new qualification testing.”

FEMA 350, *Recommended Seismic Design Criteria for New Steel Moment-Frame Buildings* includes recommendations for design and fabrication of several types of connections which are deemed to be prequalified for use in Special Moment Frames of steel. These connection designs are based on extensive testing and analysis performed by the SAC Joint Venture under a program funded by FEMA. When used within the limitations listed in FEMA 350, including Quality Control and Quality Assurance requirements, these connections should be deemed to comply with the requirements of Section 9.2.”

38. Commentary Part I, Section C9.3

Insert the following paragraph after the first paragraph of this section:

“Despite the ductility demonstrated by panel zones studies conducted by the SAC Joint Venture and others (Engelkirk, 1999) have indicated that panel zone distortions can affect the performance of beam-to-column connections. Consequently, the provisions require that the panel zone design match that of the successfully tested connections used to qualify the connection being used. The balance of the procedure of Section 9.3a is intended to provide a minimum strength level to prevent excessively weak panel zones, which may lead to unacceptable column distortion. Where prequalified connections described in FEMA 350 are used, the design of panel-zones according to the methods given therein shall be considered as meeting the requirements in Section 9.3a.”

Modify the second paragraph as follows:

“Equation 9-1 represents a design strength in the inelastic range and, therefore is for comparison to ~~factored loads~~ limiting strengths of connected members. ~~In the 1991 Uniform Building Code (ICBO, 1991), the minimum required panel zone shear strength was determined by multiplying the service load panel zone shear force by 1.85. In these Provisions and in the LFRD Specification, Load Combinations A4-5 and A4-6 are used to determine the required panel zone strength. Because all of the effects of panel-zone yielding may not be positive, ϕ is conservatively specified in these Provisions as 0.75, which results in a reliability that is approximately equivalent to that obtained with the aforementioned provisions in the 1991 Uniform Building Code; ϕ is specified for non-seismic applications as 0.9 in the LFRD Specification. . ϕ_v has been set equal to unity because ϕ is typically applied to systems to assure that they remain elastic. In this case, it is known that yielding will occur. The application of the moments at the column face to determine the required shear strength of the panel-zone recognizes that the beam hinging will take place at a location away from the beam-to-column connection, which will result in amplified effects on the panel-zone shear. The previous version of this provision included a reduction factor of 0.8 on the beam yielding effects, which was intended to recognize that, in some~~

cases, gravity loads might inhibit the development of plastic hinges on both sides of a column. However, there is no assurance that this will be the case, especially for one-sided connections and at perimeter frames where gravity loads may be relatively very small.

Delete the third paragraph that begins: "As an upper limit, the design" and replace with the following:

"This provision requires that the panel zone thickness be determined using the method used to determine the panel zone thickness in the tested connection, with a minimum value as described in the remainder of the section. The intent is that the local deformation demands on the various elements in the structure be consistent with the results of the tests that justify the use of the connection. The expected shear strength of the panel zone in relation to the maximum expected demands that can be generated by the beam(s) framing into the column in the structure should be consistent with the relative strengths that existed in the tested connection configuration. Many of the connection tests were performed with a one-sided configuration. If the structure has a two-sided connection configuration with the same beam and column sizes as a one-sided connection test, the panel zone shear demand will be about twice that of the test. Therefore, in order to obtain the same relative strength, the panel zone thickness to be provided in the structure should be approximately twice that of the test."

Change the first paragraph on page 72 as follows:

"Web doubler plates may extend between top and bottom continuity plates that are welded directly to the column web and web doubler plate or they may extend above and below top and bottom continuity plates that are welded to the doubler plate only. In the former case, the welded joint connecting the continuity plate to the column web and web doubler plate is required to be configured to transmit the proportionate force from the continuity plate to each element of the panel-zone. In the latter case, the welded joint connecting the continuity plate to the web doubler plate is required to be sized to transmit the force from the continuity plate to the web doubler plate and the web doubler plate thickness ~~and welding~~ is required to be selected to transmit this same force; minimum-size fillet welds per LRFD Specification Table J2.4 are used to connect along the column-web edges."

Delete the last paragraph on page 72 that begins with “The beneficial role of panel-zone deformation...”

39. Commentary Part I, Section C9.4

Add the following paragraph at the end of the section:

“The choice of the ratio in Equation 9-3 of 2.0 as a trigger for precluding this limit is based upon studies of inelastic analyses by Gupta and Krawinkler (1999), Bondy (1996) and others, that indicate that hinging of columns may not be precluded at ratios below 2.0. Hinging of columns that do not comply with λ_p may result in flange local buckling, which is detrimental to column performance.”

40. Commentary Part I, Section C9.7a

Change the first paragraph as follows:

“Restrained Connections: Beam-to-column connections are usually restrained laterally by the floor or roof framing. When this is the case and it can be shown that the column remains elastic outside of the panel-zone, lateral support of the column flanges is required only at the level of the top flanges of the beams. ~~Although arbitrary, the two criteria given to demonstrate that the column remains elastic are reasonable.~~ If it cannot be shown that the column remains elastic, lateral support is required at both the top and bottom beam flanges because of the potential for flexural yielding, and consequent lateral-torsional buckling, of the column.”

Add the following paragraph to the end of the section:

“The 1997 AISC Seismic Provisions required column lateral bracing when the ratio in Equation 9-3 was less than 1.25. The intent of this provision was to require bracing to prevent lateral torsional buckling for cases where it cannot be assured that the column will not hinge. Studies of inelastic analysis (Gupta and Krawinkler, 1999 and Bondy, 1996) have shown that, in severe earthquakes, plastic hinging can occur in the columns even when this ratio is significantly larger than 1.0. The revised limit of 2.0 was selected as a reasonable cut-off since column plastic hinging for values greater than 2.0 is usually associated with extremely large story drifts. Similarly, Load Combination 4-1 does not provide assurance against hinging of the column. The intention of

the revisions to this section is not to force the use of much heavier columns, as required to meet the increased ratio, but rather to assure that appropriate bracing is provided.”

41. Commentary Part I, Section C10

Add the following to the beginning of Commentary Section C10:

“General Commentary for Sections C10 and C11

As a result of the SAC program (FEMA, 2000a), the Intermediate Moment Frame (IMF) as defined in the 1997 AISC *Seismic Provisions for Structural Steel buildings* (AISC, 1997) is no longer applicable. This system has been eliminated and the Ordinary Moment Frame (OMF) as given in AISC (1997) has been split into two systems: the IMF based on a tested design procedure and the OMF based on a prescriptive design procedure. Both systems are intended primarily for construction subject to certain seismic design categories and other height restrictions (NEHRP, 2000). It is intended that the new IMF and OMF will not require the larger interstory drift angles expected of SMF, because of the use of more or larger framing members, or because of use in lower seismic zones. Because little inelastic action is required, many of the restrictions applied to the SMF are not applied to the IMF and the OMF.”

42. Commentary Part I, Section C10.1

Replace Commentary Section C10.1 with the following:

“The Intermediate Moment Frame (IMF) as given in Supplement No. 2 to the 1997 AISC *Seismic Provisions for Structural Steel Buildings* is essentially the same as the Ordinary Moment Frame (OMF) system defined in the 1997 AISC *Seismic Provisions for Structural Steel Buildings*. This new IMF is intended to provide limited levels of inelastic rotation capability and is based on a tested design.

The following building height and system limitations are given in the 2000 NEHRP Provisions (FEMA, 2000e) for the IMF:

1. There is no height limit on Seismic Design Categories (SDC) B and C.
2. The IMF can be used in buildings up to 35 feet regardless of floor and/or wall weight for SDC D.

3. The IMF is not permitted in SDC's E, and F, except as described in reference footnote 'i' and 'j'.
4. Footnote 'i' reads 'Steel ordinary moment frames and intermediate moment frames are permitted in single-story buildings up to a height of 60 feet when the moment joints of field connections are constructed of bolted end plates and the dead load of the roof does not exceed 15 psf.'"
5. Footnote 'j' also reads that IMF's 'are permitted in buildings up to a height of 35 feet where the dead load of the walls, floors, and roofs does not exceed 15 psf.'"

43. Commentary Part I, Section C10.2

Replace Commentary Section C10.2 with the following:

"The minimum interstory drift angle required for IMF connections is 0.02 radians while that for SMF connections is 0.04 radians. This level of interstory drift angle has been established for this type of frame based on engineering judgement applied to available tests and analytical studies (FEMA, 1997a; SAC, 1995d; FEMA, 2000a)."

44. Commentary Part I, Section C10.8

Delete Commentary Section C10.8.

45. Commentary Part I, Section C11.1

Replace Commentary Section C11.1 with the following:

"Similar to the IMF, the Ordinary Moment Frame (OMF) is intended to provide for limited levels of inelastic rotation capability. Unlike the IMF, the OMF is based on a prescriptive design procedure.

The following building height and system limitations are given in the 2000 NEHRP Provisions (FEMA, 2000e) for the OMF:

1. There is no height limit on Seismic Design Categories (SDC) B and C.
2. The OMF is not permitted in SDC's D, E, and F, except as described in reference footnotes 'i' and 'j'.
3. Footnote 'i' reads 'Steel ordinary moment frames and intermediate moment frames are permitted in single-story buildings up to a height of 60 feet when the moment joints of

field connections are constructed of bolted end plates and the dead load of the roof does not exceed 15 psf.’

4. Footnote ‘j’ reads ‘Steel ordinary moment frames are permitted in buildings up to a height of 35 feet where the dead load of the walls, floors, and roofs does not exceed 15 psf.’”

46. Commentary Part I, Section C11.2

Delete the second paragraph. Leave the remainder as is.

47. Commentary Part I, Section C11.3

Add the following to this section:

“When welding continuity plates to the column flanges with two-sided partial-joint-penetration groove welds combined with reinforcing fillet welds, refer to AWS D1.1 Article 2.6.2 and Annex I for an explanation of the required effective throat.

A minimum continuity plate thickness equal to the beam flange implies that a lower strength plate material may be used.

The ‘contact area’ referred to in this section, is the thickness of the continuity plate times its length, after reductions in length for access holes.”

48. Commentary Part I, Section C13.1

Modify the fourth full paragraph on page 84 as follows:

“For brace buckling out of the plane of single plate gussets, weak-axis bending in the gusset is induced by member end rotations. This results in flexible end conditions with plastic hinges at midspan in addition to the hinges that form in the gusset plate. Satisfactory performance can be ensured by allowing the gusset plate to develop restraint-free plastic rotations. This requires that the free length between the end of the brace and the assumed line of restraint for the gusset be sufficiently long to permit plastic rotations, yet short enough to preclude the occurrence of plate buckling prior to member buckling. A length of two times the plate thickness is recommended (Astaneh et al., 1986). Note that this free distance is measured from the end of the brace to a line that is perpendicular to the brace centerline, drawn from the point on the gusset plate nearest to the brace end that is constrained from out-of-plane rotation. See Figure C-13.2. Alternatively, connections with stiffness in two directions, such as crossed gusset plates, can

be detailed. Test results indicate that forcing the plastic hinge to occur in the brace rather than the connection plate results in greater energy dissipation capacity (Lee and Goel, 1987).”

49. Commentary Part I, Section C13.1

Add the following to the end of this section:

“A zipper column system and a two-story X system are illustrated in Figure C-13.4.

Two-story X and zipper-braced frames can be designed with post-elastic behavior consistent with the expected behavior of V-braced SCBF. These configurations can also capture the increase in post-elastic axial loads on beams at other levels. It is possible to design 2-story X and zipper frames with post-elastic behavior that is superior to the expected behavior of V-braced SCBF by proportioning elements to discourage single-story mechanisms.”

50. Commentary Part I, Figure C-13.2

Replace the existing Figure C-13.2 with the following Figure C-13.2.

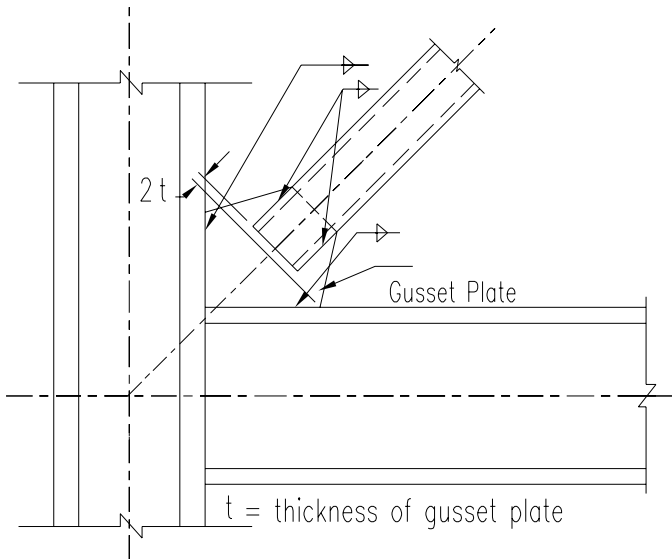

Fig. C-13.2. Brace-to-gusset plate requirement for buckling out-of-plane bracing system.

51. Commentary Part I, Section C13.2a

Change the third sentence as follows:

“Tang and Goel (1989) and Goel and Lee (1992) showed that the post-buckling cyclic fracture life of bracing members generally ~~decreases~~ increases with an increase in slenderness ratio.”

52. Commentary Part I, Section C13.3c

Change the third sentence as follows:

“Testing has demonstrated that where a single gusset plate connection is used, the rotations can be accommodated as long as the brace end is separated by at least two times the gusset thickness from a line perpendicular to the brace axis about which the gusset plate may bend unrestrained by the beam, column, or other brace joints (Astaneh et al., 1986).”

Add the following at the end of the first paragraph:

“More information on seismic design of gusset plates can be obtained from Astaneh (1998).”

53. Commentary Part I, Section C13.4a

Change the first paragraph as follows:

“V-braced and Inverted-V-Braced Frames exhibit a special problem that sets them apart from braced frames in which both ends of the braces frame into beam-column joints. Upon continued . . . The full tension force can be expected to be in the range of P_y . In addition, configurations where the beam-to-brace connection is significantly offset from the midspan location should be avoided whenever possible, since such a configuration exacerbates the unbalanced conditions cited above. The adverse effect of this unbalanced force”

54. Commentary Part I, Section C14.2

Delete Commentary Sections 14.2 through 14.5 and replace with the following:

C14.2. Strength

In the 1997 AISC Seismic Provisions, there were relatively few differences between Ordinary Concentrically Braced Frames (OCBFs) and Special Concentrically Braced Frames (SCBFs). It is believed that, despite the lower R value given in NEHRP (FEMA, 1997a), these systems may not perform well in large ground motions. Consequently

the OCBF provisions, except those previously given for “Low Buildings” in Section 14.5, have been eliminated, and limits on the use of OCBFs to those building types are presented in the 2000 NEHRP Provisions (FEMA, 2000e).

The specific reasons for elimination of most of the OCBF provisions that were in the 1997 AISC Seismic Provisions are as follows:

1. Section 14.3a.b allows connections to be designed for a strength that may be less than that of the braces themselves. This will preclude ductile performance of the system.
2. Section 14.4a.1 requires that braces in V-Type and Inverted V-Type bracing systems be designed for “at least 1.5 times the strength using LRFD Specification Load combinations A4-5 and A4-6.” This may lead to overly strong bracing, which will be capable of buckling the columns of the braced frame, and may lead to collapse.
3. Section 14.4a.3 does not provide for sufficient beam strength to maintain the strength of the tension brace after buckling of the compression brace. The result is that buckling of the compression brace can lead to a sudden and dramatic reduction in the story strength.

The provisions in Section 13 for SCBF’s preclude all the above undesirable characteristics. It is the intent that SCBF’s be used for all concentrically braced frames where significant ductility is needed. In order to accomplish this, the following items are included in the 2000 NEHRP Provisions (FEMA, 2000e):

1. The use of Ordinary Steel Concentrically Braced Frames (OCBF’s) in the Dual Systems is not included.
2. The height limit of Seismic Design Categories (SDC) D and E are limited to 35 ft and OCBF’S are not permitted for SDC F, except as noted below.
3. Each of these three categories has a reference footnote “k”.

4. The footnote “k” reads “Steel ordinary braced frames are permitted in single story buildings up to a height of 60 ft when the dead load of the roof does not exceed 15 psf, and in penthouse structures.”

The application of Load Combinations 4-1 and 4-2 to determine the member size and connections other than bracing connections, in SDC D and E buildings with an R factor of about 2.5 would provide sufficient strength to preclude the need for significant ductility of the system.

The effect of these modifications on the design of steel concentrically braced frames in comparison to those designed in accordance with the 1997 AISC Seismic Provisions will be as follows:

1. Most concentrically braced frames will be classified as SCBF’s.
2. V-Type and Inverted V-Type SCBF frames will have lighter braces, but significantly heavier floor beams.
3. All configurations will be permitted to use larger Kl/r values, which may result in lighter braces. Connections of the braces may be heavier, depending upon whether or not the requirement to develop the strength of the braces for SCBF’s is offset by the lighter bracing.

55. **Commentary Part I, Section C16**

Add the following:

“Commentary Section C6.3 indicates that the k-area of rotary-straightened wide-flange columns may have reduced notch toughness. Preliminary recommendations (AISC, 1997) discouraged the placement of welds in this area due to the susceptibility to post-weld cracking that has occurred on past projects. Where such welds are to be placed, it is deemed necessary to perform inspections to verify that such cracking has not occurred. Typically, such inspections would incorporate magnetic particle or dye penetrant testing with acceptance criteria as specified in AWS D1.1. The required frequency of such inspections should be specified in the contract documents.

FEMA 353, *Recommended Specifications and Quality Assurance Guidelines for Steel Moment-Frame Construction for Seismic Applications*” is a reference for the preparation of a quality assurance plan for steel Special Moment Frames and Intermediate Moment Frames, as well as for other seismic force resisting systems. In addition building codes require specific quality assurance plan requirements.”

56. Commentary Appendix S, Section CS1

Change the last paragraph of this section as follows:

“When developing a test program, the designer should be aware that regulatory agencies may impose additional testing and reporting requirements not covered in this Appendix. Examples of testing guidelines or requirements developed by other organizations or agencies include those published by SAC (~~FEMA, 1995; FEMA, 199b~~ FEMA, 2000a; SAC, 1997),.... <remainder unchanged>”

57. Commentary Appendix S, Section CS3

Add the following to the beginning of this section:

“Interstory Drift Angle

The interstory drift angle developed by a connection test specimen is the primary acceptance criterion for a beam-to-column moment connection in a moment frame. In an actual building, the interstory drift angle is computed as the interstory displacement divided by the story height, and includes both elastic and inelastic components of deformation. For a test specimen, interstory drift angle can usually be computed in a straightforward manner from displacement measurements on the test specimen. Guidelines for computing the interstory drift angle of a connection test specimen are provided by SAC (1997).”

Change the existing definition as follows:

“Inelastic Rotation

One of the key parameters measured in a connection test is the inelastic rotation that can be developed in the specimen. Previously in these Provisions, inelastic rotation was the primary acceptance criterion for beam-to-column moment connections in moment frames. The acceptance criterion in the Provisions is now based on interstory drift angle, which includes both elastic and inelastic rotations. However, inelastic rotation provides an important

indication of connection performance in earthquakes and should still be measured and reported in connection tests. For the purpose of demonstrating conformance with requirements in these Provisions, inelastic rotation of a moment connection is required to be computed based on the assumption that all inelastic deformation of a test specimen is concentrated at a single point at the face of the column. In reality, inelastic deformations are distributed over a finite length of the members and/or the connection elements. For many connection types used since the Northridge Earthquake, the portion of the beam subject to yielding is located some distance away from the face of the column. In other cases, yielding may be located within the column panel zone. Researchers have used a variety of different definitions for inelastic rotation of connection test specimens in the past, making comparison among tests difficult. In order to promote consistency in how test results are reported, these Provisions require that inelastic rotation be computed based on the assumption that all inelastic deformation of a test specimen is concentrated at a single point at the intersection of the centerline of the beam with the centerline of the column. With this definition, inelastic rotation is equal to the inelastic portion of the interstory drift angle. Previously in the Provisions, inelastic rotation was defined to be computed with respect to the face of the column. The definition has been changed to the centerline of the column to be consistent with recommendations of SAC (SAC, 1997; FEMA, 2000a).

~~Regardless of where the actual inelastic deformation occurs... (delete this entire paragraph).~~

The computation of the inelastic rotation requires an analysis of test specimen deformations (SAC, 1997). ~~Examples of such calculations for moment connections can be found in SAC (1996).~~

For tests of Link-to-column connections...(last paragraph unchanged).”

58. **Commentary Appendix S, Section CS6**

Replace the first paragraph with the following revision:

“The loading sequence prescribed in Section S6.2 for beam-to-column moment connections is taken from SAC/BD-97/02, “Protocol for Fabrication, Inspection, Testing, and Documentation

of Beam-to-Column Connection Tests and Other Experimental Specimens” (SAC, 1997). This document should be consulted for further details of the loading sequence, as well as for further useful information on testing procedures. The prescribed loading sequence is not intended to represent the demands presented by an actual earthquake ground motion. This loading sequence was developed based on a series of non-linear time history analyses of steel moment frame structures subjected to a range of seismic inputs. The maximum deformation, as well as the cumulative deformation and dissipated energy sustained by beam-to-column connections in these analyses, were considered when establishing the prescribed loading sequence and the connection acceptance criteria. If a designer conducts a non-linear time history analysis of a moment frame structure in order to evaluate demands on the beam-to-column connections, considerable judgement will be needed when comparing the demands on the connection predicted by the analysis with the demands placed on a connection test specimen using the prescribed loading sequence. In general, however, a connection can be expected to provide satisfactory performance if the cumulative plastic deformation, and the total dissipated energy sustained by the test specimen prior to failure are equal or greater to the same quantities predicted by a non-linear time-history analysis. When evaluating the cumulative plastic deformation, both total rotation (elastic plus inelastic) as well as inelastic rotation at the connection should be considered. SAC/BD-00/10 can be consulted for further information on this topic.

The loading sequence specified in SAC/BD-97/02 was specifically developed for connections in Moment Frames, and may not be appropriate for testing of link-to-column connections in EBFs. Inelastic deformation of EBFs generally initiates at much lower interstory drift angles than in moment frames. The loading cycles prescribed for moment frame connection test specimens at interstory drift angles less than 0.01 rad will generally be in the elastic range. However, for typical EBFs, yielding in the links may initiate at interstory drift angles less than 0.00375 rad. Consequently, using the loading sequence prescribed for moment frames may result in an excessive number of inelastic loading cycles for an EBF test specimen. Further, the relationship between interstory drift angle and link rotation angle in an EBF is

dependent on the frame geometry. Consequently, prescribing a loading history for link-to-column connection tests based on interstory drift angle may lead to inconsistent test results. Since acceptance criteria for link-to-column connections are based on the link rotation angle, then a prescribed loading history based on the link rotation angle will provide for more consistent test results. No standard loading sequence has been developed for testing of link-to-column connections. The loading sequence prescribed in Section S6.3 was chosen based on judgement and a review of typical loading sequences used in past EBF testing.

The loading sequence specified in ATC-24, 'Guidelines for Cyclic Seismic Testing of Components of Steel Structures,' (Applied Technology Council, 1992) is considered as an acceptable alternative to those prescribed in Sections S6.2 and S6.3. Further, any other loading sequence may be used for beam-to-column moment connections or link-to-column connections, as long as the loading sequence is equivalent or more severe than those prescribed in Sections S6.2 and S6.3. To be considered as equivalent or more severe, alternative loading sequences should meet the following requirements: 1) the number of inelastic loading cycles should be at least as large as the number of inelastic loading cycles resulting from the prescribed loading sequence; and (2) the cumulative plastic deformation should be at least as large as the cumulative plastic deformation resulting from the prescribed loading sequence."

59. Commentary Part II, Section C1

Change the first paragraph as follows:

"These Provisions for the seismic design of composite structural steel and reinforced concrete buildings are based upon the 1994 NEHRP Provisions (FEMA, 1994) and subsequent modifications made in the 1997 NEHRP Provisions (FEMA, 1997a). ~~Chapter 10 of the 1997 NEHRP Provisions references these provisions for detailing and design requirements for composite structures. It is anticipated that the 2000 IBC (ICC, 1997), which is currently in preparation, will similarly reference these Provisions.~~ Since composite systems are assemblies of steel and concrete components, Part I of these Provisions, the LRFD Specification (AISC, 1999) and ACI 318 (ACI, 1995), form an important basis for Part II."

60. Commentary Part II, Section C4

Change this section as follows:

“In general, requirements for loads and load combinations for composite structures are similar to those described in Part I Section C4. Specific seismic design, loading criteria and usage limitations for composite structures are specified in the 2000 NEHRP Provisions (FEMA, 2000e). ~~However, the 1997 NEHRP Provisions is currently the only code or standard that includes specific seismic loading criteria for these new composite structures. As indicated above, it is anticipated that the 2000 IBC (ICC, 1997) will include seismic loading provisions similar to those in the 1997 NEHRP Provisions.~~

The calculation of seismic forces for composite systems per the 2000 NEHRP Provisions (FEMA, 2000e)~~1997 NEHRP Provisions~~ is the same as is described for steel structures in Part I Commentary Section C4. Table II-C4-1 lists the seismic response modification factors R and C_d for the 2000 NEHRP Provisions (FEMA, 2000e)~~1997 NEHRP Provisions~~. The values in Table II-C4-1 are predicated upon meeting the design and detailing requirements for the composite systems as specified in these provisions. Overstrength factors for the composite systems given in Table II-4-1 of these Provisions are the same as those specified in the 2000 NEHRP Provisions (FEMA, 2000e)~~1997 NEHRP Provisions~~.

ACI 318 Appendix C has been included ... <paragraph unchanged>... in lieu of those in ACI 318 Chapter 9.

The seismic response modification factors R and C_d for composite systems specified by the 2000 NEHRP Provisions (FEMA, 2000e)~~1997 NEHRP Provisions~~ are similar ...<remainder unchanged>”

61. Commentary Part II, Section C13

Change the first paragraph as follows:

“C-CBF is one of the two types of composite braced frames that is specially detailed for Seismic Design Categories C and above; the other is C-EBF (see Table II-C4-1). While experience using C-CBF is limited in high seismic regions, the design provisions for C-CBF are intended to result in behavior comparable to steel

SCBF ~~OCBF~~, wherein the braces often are the elements most susceptible to inelastic deformations (see Part I Commentary Section C13 ~~C14~~). The R and C_d values and usage limitations for C-CBF are similar to the same as those for steel SCBF ~~OCBF~~.”

62. References

Add the following references:

American Institute of Steel Construction, Inc., 1999, *Load and Resistance Factor Design Specification for Structural Steel Buildings*, AISC, Chicago, IL.

American Institute of Steel Construction, Inc., 1997, *Seismic Provisions for Structural Steel Buildings*, AISC, Chicago, IL.

Astaneh, A., 1998, “Seismic Behavior and Design of Gusset Plates for Braced Frames,” *Steel Tips*, Structural Steel Education Council, Moraga, CA.

Bondy, K.P., 1996, “A More Rational Approach to Capacity Design of Seismic Moment Frame Columns,” *Earthquake Spectra*, Volume 12, No. 3, (August, 1996), EERI, Oakland, CA.

Engelkirk, R.E., 1999, “Extant Panel Zone Design Procedures for Steel Frames are Questioned,” *Earthquake Spectra*, Volume 15, No. 2, (May 1999), pp. 361-370, EERI, Oakland, CA.

Federal Emergency Management Agency, 2000a, *FEMA 350 Recommended Seismic Design Criteria for New Steel Moment-Frame Buildings*, FEMA, Washington, D.C.

Federal Emergency Management Agency, 2000b, *FEMA 351 Recommended Seismic Evaluation and Upgrade Criteria for Welded Moment-Resisting Steel Frame Structures*, FEMA, Washington, D.C.

Federal Emergency Management Agency, 2000c, *FEMA 352 Recommended Post-Earthquake Evaluation and Repair Criteria for Welded Moment-Resisting Steel Frame Structures*, FEMA, Washington, D.C.

Federal Emergency Management Agency, 2000d, FEMA 353 *Recommended Specifications and Quality Assurance Guidelines for Steel Moment-Frame Construction for Seismic Applications*, FEMA, Washington, D.C.

Federal Emergency Management Agency, 2000e, *NEHRP (National Earthquake Hazards Reduction Program) Recommended Provisions for Seismic Regulations for New Buildings*, FEMA, Washington, D.C.

Gupta, A. and Krawinkler, H., 1999, *Prediction of Seismic Demands for SMRF's with Ductile Connections and Elements*, SAC/BD-99/06, SAC Joint Venture, Sacramento, CA.

SAC, 1997, SAC/BD-97/02 Version 1.1, "Protocol for Fabrication, Inspection, Testing, and Documentation of Beam-Column Connection Tests and Other Specimens," SAC Joint Venture, Sacramento, CA.

Change the reference Schneider (1998) as follows:

Schneider, S.P., 1998, "Axially Loaded Concrete-Filled Tubes," *Journal of Structural Engineering*, Vol. 124, No. 10, pp. 1125-1138, ASCE, Reston, VA.



American Institute of Steel Construction, Inc.
One East Wacker Drive, Suite 3100
Chicago, IL 60601-2001

Pub. No. S341s (XXXXXX)