

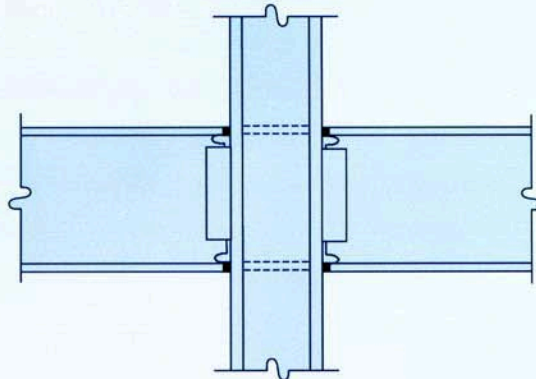

Steel Design Guide Series

13

*Stiffening of Wide-Flange Columns
at Moment Connections:
Wind and Seismic Applications*





13

Steel Design Guide Series

Stiffening of Wide-Flange Columns at Moment Connections: Wind and Seismic Applications

Charles J. Carter, PE

American Institute of Steel Construction, Inc.
Chicago, IL

Copyright © 1999

by

American Institute of Steel Construction, Inc.

*All rights reserved. This book or any part thereof
must not be reproduced in any form without the
written permission of the publisher.*

The information presented in this publication has been prepared in accordance with recognized engineering principles and is for general information only. While it is believed to be accurate, this information should not be used or relied upon for any specific application without competent professional examination and verification of its accuracy, suitability, and applicability by a licensed professional engineer, designer, or architect. The publication of the material contained herein is not intended as a representation or warranty on the part of the American Institute of Steel Construction or of any other person named herein, that this information is suitable for any general or particular use or of freedom from infringement of any patent or patents. Anyone making use of this information assumes all liability arising from such use.

Caution must be exercised when relying upon other specifications and codes developed by other bodies and incorporated by reference herein since such material may be modified or amended from time to time subsequent to the printing of this edition. The Institute bears no responsibility for such material other than to refer to it and incorporate it by reference at the time of the initial publication of this edition.

Printed in the United States of America

Second Printing: October 2003

TABLE OF CONTENTS

1. Introduction	1	5.2 Column Stiffening for Weak-Axis Moment Connections	33
1.1 Scope	1	5.3 Column Stiffening for Concurrent Strong- and Weak-Axis Moment Connections	34
1.2 Column Stiffening	2	5.4 Web Doubler Plates as Reinforcement for Local Web Yielding, Web Crippling, and/or Compression Buckling of the Web.	35
1.3 References Specifications	2	5.5 Web Doubler Plates at Locations of Weak-Axis Connections	35
1.4 Definitions of Wind, Low-Seismic, and High-Seismic Applications.	2	5.6 Diagonal Stiffeners	36
1.5 Acknowledgements.	2		
2. Strong-Axis Moment Connections to Unreinforced Columns	3	6. Design Examples	39
2.1 Force Transfer in Unreinforced Columns	3	Example 6-1.	39
2.2 Determining the Design Strength of an Unreinforced Column	5	Example 6-2.	40
2.3 Column Cross-Sectional Stiffness Considerations	11	Example 6-3.	41
2.4 Design Aids.	11	Example 6-4.	45
3. Economical Selection of Columns	13	Example 6-5.	47
3.1 Achieving Balance Between Increases in Material Cost and Reductions in Labor Cost.	13	Example 6-6.	47
3.2 Eliminating Column Stiffening.	14	Example 6-7.	50
3.3 Minimizing the Economic Impact of Column Stiffening Requirements in Wind and Low-Seismic Applications.	15	Example 6-8.	52
3.4 Minimizing the Economic Impact of Column Stiffening Requirements in High-Seismic Applications.	16	Example 6-9.	52
4. Strong-Axis Moment Connections to Stiffened Columns	17	Example 6-10.	54
4.1 Determining the Column Stiffening Requirements	18	Example 6-11.	55
4.2 Force Transfer in Stiffened Columns	20	Example 6-12.	58
4.3 Design of Transverse Stiffeners	22	Example 6-13.	59
4.4 Design of Web Doubler Plates	27	Example 6-14.	61
5. Special Considerations	33	APPENDIX A	67
5.1 Column Stiffening for Beams of Differing Depth and/or Top of Steel.	33	APPENDIX B.	75
		APPENDIX C	83
		APPENDIX D	95
		Special Considerations.	95
		Moment Connections to Column Webs.	99

Chapter 1

INTRODUCTION

1.1 Scope

The design of columns for axial load, concurrent axial load and flexure, and drift considerations is well established. However, the consideration of stiffening requirements for wide-flange columns at moment connections as a routine criterion in the selection of the components of the structural frame is not as well established. Thus, the economic benefit of selecting columns with flange and web thicknesses that do not require stiffening is not widely pursued, in spite of the efforts of other authors who have addressed this topic previously (Thornton, 1991; Thornton, 1992; Barger, 1992; Dyker, 1992; and Ricker, 1992). This Design Guide is written with the intent of changing that trend and its contents are focused in two areas:

1. The determination of design strength and stiffness for unreinforced wide-flange columns at locations of strong-axis beam-to-column moment connections; and,
2. The design of column stiffening elements, such as transverse stiffeners (also known as continuity plates) and web doubler plates, when the unreinforced column strength and/or stiffness is inadequate.

Recommendations for economy are included in both cases.

Force transfer and design strength of unreinforced columns with strong-axis moment connections are covered

in Chapter 2. Economical considerations for unreinforced columns and columns with reinforcement are given in Chapter 3. Force transfer and design strength of reinforced columns with strong-axis moment connections, as well as the design of transverse stiffeners and web doubler plates, is covered in Chapter 4. Special considerations in column stiffening, such as stiffening for weak-axis moment connections and framing arrangements with offsets, are covered in Chapter 5. Design examples that illustrate the application of these provisions are provided in Chapter 6, with design aids for wind and low-seismic applications in Appendices A, B, and C.

1.2 Column Stiffening

Transverse stiffeners are used to increase the strength and/or stiffness of the column flange and/or web at the location of a concentrated force, such as the flange force induced by the flange or flange-plate of a moment-connected beam. Web doubler plates are used to increase the shear strength and stiffness of the column panel-zone between the pair of flange forces from a moment-connected beam. The panel-zone is the area of the column that is bounded by the column flanges and the projections of the beam flanges as illustrated in Figure 1-1.

If transverse stiffeners and/or web doubler plates carry loads from members that frame to the weak-axis of the

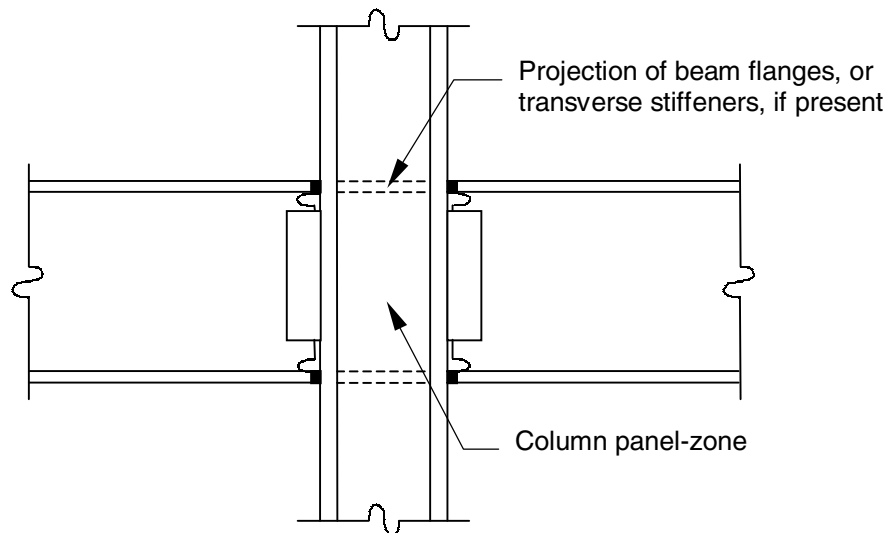

Figure 1-1 Illustration of column panel-zone.

column, the recommendations herein must be adjusted as discussed in Sections 5.2, 5.3, and 5.5. As discussed in Section 5.4, if web doubler plates are required to increase the panel-zone shear strength, they can also be used to resist local web yielding, web crippling, and/or compression buckling of the web per LRFD Specification Section K1. As discussed in Section 5.6, diagonal stiffening can be used in lieu of web doubler plates if it does not interfere with the weak-axis framing.

1.3 References Specifications

This Design Guide is generally based upon the requirements in the AISC LRFD *Specification for Structural Steel Buildings* (AISC, 1993), hereinafter referred to as the LRFD Specification, and the AISC *Seismic Provisions for Structural Steel Buildings* (AISC, 1997a), hereinafter referred to as the AISC Seismic Provisions. Although direct reference to the AISC *Specification for Structural Steel Buildings—Allowable Stress Design and Plastic Design* (AISC, 1989) is not included, the principles herein remain generally applicable.

1.4 Definitions of Wind, Low-Seismic, and High-Seismic Applications

For the purposes of this Design Guide, wind, low-seismic and high-seismic applications are defined as follows. Wind and low-seismic applications are those for which the structure is designed to meet the requirements in the LRFD Specification with no special seismic detailing. This includes all applications for which the structural response is intended to remain in the nominally elastic range and the response modification factor R used in the determination of seismic forces, if any, is not taken greater than 3.

High-seismic applications are those for which inelastic behavior is expected in the beams or panel-zones as a means of dissipating the energy induced during strong ground motions. Such buildings are designed to meet the requirements in both the LRFD Specification and the AISC Seismic Provisions and a response modification factor R that is appropriate for the level of detailing required for the moment-frame system selected is used in the determination of seismic forces.¹ Additionally, the moment connections used in high-seismic applications have special seismic detailing that is appropriate for the moment-frame system selected.

1.5 Acknowledgements

This Design Guide resulted partially from work that was done as part of the Design Office Problems activity of the ASCE Committee on Design of Steel Building Structures. Chapter 3 is based in large part upon this previous work. Additionally, the AISC Committee on Manuals and Textbooks has enhanced this Design Guide through careful scrutiny, discussion, and suggestions for improvement. The author thanks the members of these AISC and ASCE Committees for their invaluable input and guidance. In particular, Lawrence A. Kloiber, James O. Malley, and David T. Ricker contributed significantly to the development of Chapters 3 and 4 and William C. Minchin and Thomas M. Murray provided helpful comments and suggestions throughout the text of this Design Guide.

¹From AISC Seismic Provisions Commentary Table I-C4-1, R -values of 8, 6, and 4 are commonly used for Special Moment Frames (SMF), Intermediate Moment Frames (IMF), and Ordinary Moment Frames (OMF), respectively.

Chapter 2

STRONG-AXIS MOMENT CONNECTIONS TO UNREINFORCED COLUMNS

In wind and low-seismic applications, it is often possible to use wide-flange columns without transverse stiffeners and web doubler plates at moment-connected beams. To use an unreinforced column, the following criteria must be met:

1. The required strength (Section 2.1) must be less than or equal to the design strength (Section 2.2); and,
2. The stiffness of the column cross-section must be adequate to resist the bending deformations in the column flange (Section 2.3).

If these criteria cannot be met, column stiffening is required.

In high-seismic applications, transverse stiffeners are normally required, as discussed in Section 2.3. However, it remains possible in many cases to use wide-flange columns in high-seismic applications without web doubler plates at moment-connected beams.

2.1 Force Transfer in Unreinforced Columns

In an unreinforced column, concentrated forces from the beam flanges or flange plates are transferred locally into the column flanges. These concentrated forces spread through the column flange and flange-to-web fillet region into the web as illustrated in Figure 2-1a. Shear is dispersed between them in the column web (panel-zone) as illustrated in Figure 2-1b. Ultimately, axial forces in the column flanges balance this shear as illustrated in Figure 2-1c.

2.1.1 Required Strength for Local Flange and Web Limit States

In wind and low-seismic applications, beam end moments, shears, and axial forces are determined by analysis for the loads and load combinations in LRFD Specification Section A4.1. Note that the total design moment is seldom equal to the flexural strength of the beam(s). A rational approach such as that illustrated in Example 6-4 or similar to that proposed by Disque (1975) can be used in conjunction with these loads and load combinations. Different load combinations may be critical for different local-strength limit states.

For the general case, the beam end moment is resolved at the column face into an effective tension-compression

couple in the beam flanges or flange plates. The corresponding flange force P_{uf} is calculated as:

$$P_{uf} = \frac{M_u}{d_m} \pm \frac{P_u}{2} \quad (2.1-1)$$

where

P_{uf} = factored beam flange force, tensile or compressive, kips

M_u = factored beam end moment, kip-in.

d_m = moment arm between the flange forces,² in.

P_u = factored beam axial force, kips

The formulation of Equation 2.1-1 is such that the combined effect of the moment and axial force is transmitted through the flange connections, ignoring any strength contribution from the web connection, which is usually more flexible.

When the moment to be developed is less than the full flexural strength of the beam, as is commonly the case when a drift criterion governs the design, and the axial force is relatively small, this calculation is fairly straightforward. However, when the full flexural strength of the beam must be developed, or when the axial force is large, such a model seems to guarantee an overstress in the beam flange, particularly for a directly welded flange moment connection. Nonetheless, the above force transfer model remains acceptable because inelastic action into the range of strain hardening allows the development of the design flexural strength of the beam in the connection (Huang et al., 1973). Such self-limiting inelastic action is permitted in LRFD Specification Section B9. Alternatively, a web connection with a stiffness that is compatible with that of the connections of the beam flanges can be used to activate the full beam cross-section and reduce the portion carried by the flanges.

Note that, if a composite moment connection is used between the beam and column, the calculations in Equations 2.1-1 and 2.1-2 must be adjusted based upon the appropriate

²The actual moment arm can be readily calculated as the distance between the centers of the flanges or flange plates as illustrated in Figure 2-1a. Alternatively, as stated in LRFD Specification Commentary Section K1.7, 0.95 times the beam depth has been conservatively used for d_m in the past.

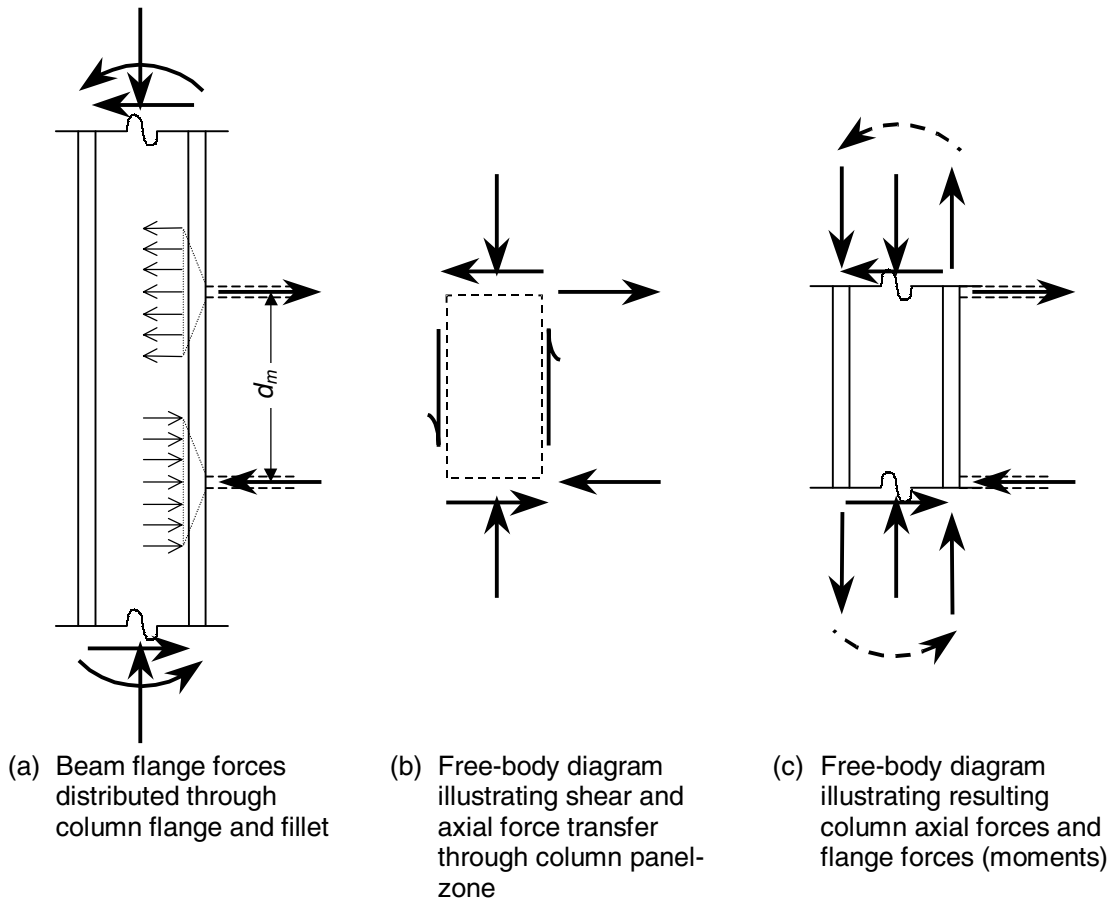

Note: beam shear and axial force (if any) omitted for clarity.

Figure 2-1 Force transfer in unreinforced columns.

detailing and force transfer model. Some possible composite connections are illustrated in AISC (1997a), Leon et al. (1996), and Viest et al. (1998).

In high-seismic applications, the moments, shears, and axial forces are determined by analysis for the loads and load combinations in LRFD Specification Section A4.1 and AISC Seismic Provisions Section 4.1. The resulting flange force P_{uf} is then determined using Equation 2.1-1. Note that the corresponding connection details have special seismic detailing to provide for controlled inelastic deformations during strong ground motion as a means of dissipating the input energy from an earthquake.³

For Ordinary Moment Frames (OMF), a cyclic inelastic rotation capability of 1 percent is required. Moment connections such as those discussed in AISC Seismic Provisions Commentary Section C11.2 and illustrated in

³With strong panel-zones and fully restrained (FR) construction, the primary source of inelasticity is commonly hinging in the beam itself. If the panel-zone is a significant source of inelasticity, or if partially restrained (PR) construction is used, the flange-force calculation in Equation 2.1-2 should be adjusted based upon the actual force transfer model.

Figure C-11.1 can be used. From AISC Seismic Provisions Section 11.2a, the flange forces in Ordinary Moment Frames (OMF) need not be taken greater than those that correspond to a moment M_u equal to $1.1R_yF_yZ_x$ or the maximum moment that can be delivered by the system, whichever is less.

For Special Moment Frames (SMF) and Intermediate Moment Frames (IMF), a cyclic inelastic rotation capability of 3 and 2 percent, respectively, is required. Several alternative connection details using reinforcement, such as coverplates, ribs, or haunches, or using reduced beam sections (dogbones), have been successfully tested and used. Such connections shift the location of the plastic hinge into the beam by a distance a from the column face as illustrated in Figure 2-2. From AISC Seismic Provisions Section 9.3a, the flange forces in Special Moment Frames (SMF) and Intermediate Moment Frames (IMF) need not be taken greater than:

$$P_{uf} = \frac{M_u}{d_m} = \frac{1.1R_yF_yZ + V_u a}{d_m} \quad (2.1-2)$$

where 1.1 is an adjustment factor that nominally accounts for the effects of strain hardening, and

- R_y = an adjustment factor that nominally accounts for material yield overstrength per AISC Seismic Provisions Section 6.2
 - = 1.5 for ASTM A36 wide-flange beams
 - = 1.3 for ASTM A572 grade 42 wide-flange beams
 - = 1.1 for wide-flange beams in other material grades (e.g., ASTM A992 or A572 grade 50)
- F_y = beam specified minimum yield strength, ksi
- Z = plastic section modulus of beam cross-section at hinge location (distance a from column face), in.³
- V_u = shear in beam at hinge location (distance a from column face), kips
- a = distance from face of column flange to plastic hinge location, in.

The axial force effect is neglected in Equation 2.1-2, since the model is already based conservatively upon the fully yielded and strain-hardened beam flange at the critical section.

2.1.2 Required Strength for Panel-Zone Shear

As illustrated in Figure 2-3, the total panel-zone shear force V_u at an interior column results from the combined effects of two moment-connected beams and the story shear V_{us} . In wind and low-seismic applications, the total panel-zone shear force V_u is calculated as:

$$V_u = (P_{uf})_1 + (P_{uf})_2 - V_{us} \quad (2.1-3)$$

In high-seismic applications, when the flange forces have been calculated using the moment resulting from AISC

Seismic Provisions Load Combinations 4-1 and 4-2 and Equation 2.1-1, the total panel-zone shear force is calculated with Equation 2.1-3. As a worst case, however, the total panel-zone shear force V_u need not be taken greater than:

$$V_u = 0.8[(P_{uf})_1 + (P_{uf})_2] - V_{us} \quad (2.1-4)$$

The factor 0.8 in Equation 2.1-4 is from AISC Seismic Provisions Section 9.3a. It recognizes that the effect of the gravity loads will counteract some portion of the effect of the lateral loads on one side of an interior column and thereby inhibit the development of the full plastic moment in the beam on that side.

In wind, low-seismic, and high-seismic applications, for a column with only one moment-connected beam, Equation 2.1-3 can be reduced to:

$$V_u = P_{uf} - V_{us} \quad (2.1-5)$$

Note that gravity-load reduction, as used for high-seismic applications in Equation 2.1-4, is not appropriate in Equation 2.1-5 for a column with only one moment-connected beam.

2.2 Determining the Design Strength of an Unreinforced Column

An unreinforced column must have sufficient strength locally in the flange(s) and web to resist the resulting flange-force couple(s). Moment connections are termed “double concentrated forces” in LRFD Specification Section K1 because there is one tensile flange force and one compressive flange force acting on the same side of the column as illustrated in Figure 2-4a. When opposing moment-

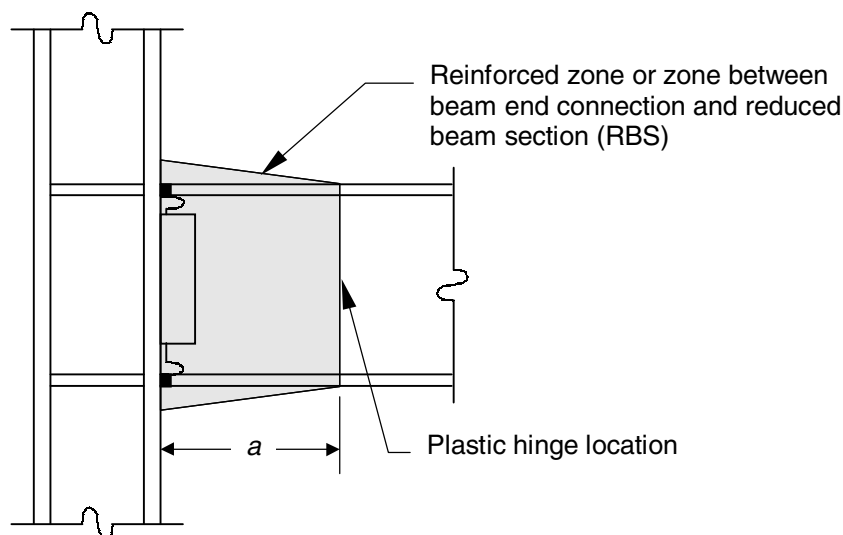

Figure 2-2 Schematic illustration of moment connection for high-seismic applications.

connected beams coincide, a pair of double concentrated forces results as illustrated in Figures 2-4b (the gravity load case) and 2-4c (the lateral load case).

The design strength of the panel-zone in shear must be checked for all columns with moment connected beams. For a tensile flange force, the design strength of the flange in local flange bending and the design strength of the web in local yielding must also be checked. For a compressive flange force, the design strength of the web in local yielding, crippling, and compression buckling must be checked. Note that the compression buckling limit state is applicable only when the compressive components of a pair of double concentrated forces coincide as illustrated in Figure 2-4b (i.e., at the bottom flanges). If the magnitudes of these opposing flange forces are not equal, the compression buckling limit state is checked for the smaller flange force, since only this portion of the larger flange force must be resisted. Each of these limit states is discussed below.

2.2.1 Panel-Zone Shear Strength

In wind and low-seismic applications and high-seismic applications involving Ordinary Moment Frames (OMF), the design shear strength of the panel-zone ϕR_v is determined with the provisions of LRFD Specification Section K1.7, which allows two alternative assumptions.

The first assumption is that, for calculation purposes, the behavior of the panel-zone remains nominally within the elastic range. The resulting design strength given in Equations 2.2-1 and 2.2-2 is then determined from LRFD Specification Equations K1-9 or K1-10 with consideration of the magnitude of the axial load P_u in the column:

$$\text{For } P_u \leq 0.4P_y, \quad \phi R_v = 0.9 \times 0.6F_y d_c t_w \quad (2.2-1)$$

$$\text{For } P_u > 0.4P_y, \quad \phi R_v = 0.9 \times 0.6F_y d_c t_w \left(1.4 - \frac{P_u}{P_y} \right) \quad (2.2-2)$$

In the second assumption, it is recognized that significant post-yield panel-zone strength is ignored by limiting the calculated panel-zone shear strength to that in the nominally elastic range. At the same time, it must be realized that inelastic deformations of the panel-zone can significantly impact the strength and stability of the frame. Accordingly, a higher strength can generally be utilized as long as the effect of inelastic panel-zone deformation on frame stability is considered in the analysis. When this option is selected, the resulting design strength given in Equations 2.2-3 and 2.2-4 is determined from LRFD Specification Equations K1-11 and K1-12 with consideration of the magnitude of the axial load P_u in the column:

$$\text{For } P_u \leq 0.75P_y,$$

$$\phi R_v = 0.9 \times 0.6F_y d_c t_w \left(1 + \frac{3b_f t_f^2}{d_b d_c t_w} \right) \quad (2.2-3)$$

$$\text{For } P_u > 0.75P_y,$$

$$\phi R_v = 0.9 \times 0.6F_y d_c t_w \left(1 + \frac{3b_f t_f^2}{d_b d_c t_w} \right) \left(1.9 - \frac{1.2P_u}{P_y} \right) \quad (2.2-4)$$

For F_y equal to or less than 50 ksi, all W-shapes listed in ASTM A6 except a W30 × 90 and a W16 × 31 have a web thickness that is adequate to prevent buckling

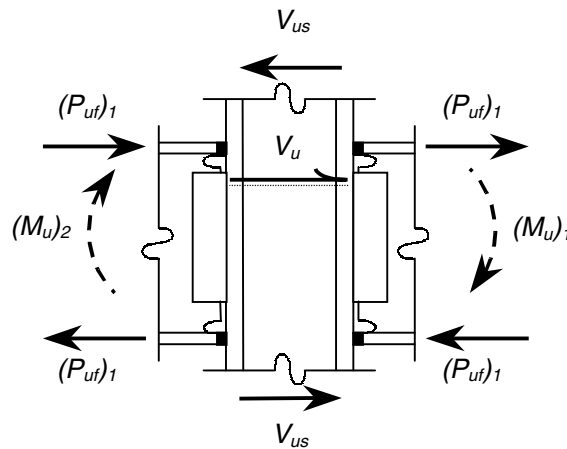

Note: shear forces in beams and moments and axial forces in column omitted for clarity.

Figure 2-3 Panel-zone web shear at an interior column (with moment-connected beams bending in reverse curvature).

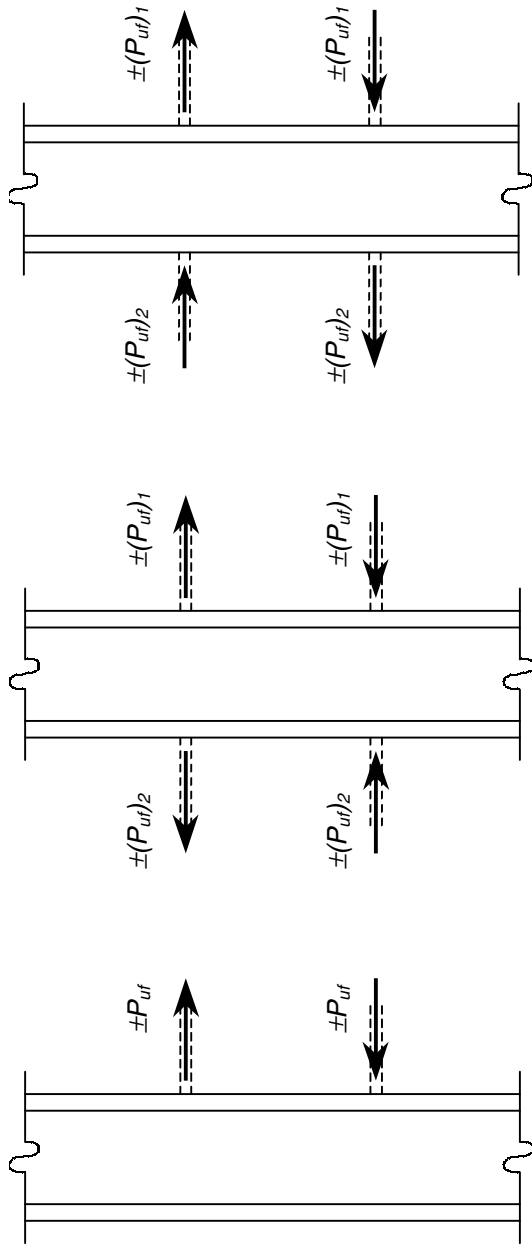

(a) Double concentrated forces

(b) A pair of double concentrated forces,
gravity load case

(c) A pair of double concentrated forces,
lateral load case

Figure 2-4 Moment connection flange force terminology.

under panel-zone web shear per LRFD Specification Section F2. For $F_y = 50$ ksi, these two shapes exceed the limit on h/t_w by 1.9 and 1.5 percent, respectively. Thus, for all practical purposes, in wind and low-seismic applications, shear buckling of the column web need not be checked for columns with F_y equal to or less than 50 ksi.⁴

In high-seismic applications involving Special Moment Frames (SMF) or Intermediate Moment Frames (IMF), the effect of inelastic panel-zone deformation on frame stability must be considered in the analysis. The design shear strength of the panel-zone ϕR_v given in Equations 2.2-5 and 2.2-6 is determined from AISC Seismic Provisions Section 9.3a:

For $P_u \leq 0.75P_y$,

$$\phi R_v = 0.75 \times 0.6F_y d_c t_w \left(1 + \frac{3b_f t_f^2}{d_b d_c t_w} \right) \quad (2.2-5)$$

For $P_u > 0.75P_y$,

$$\phi R_v = 0.75 \times 0.6F_y d_c t_w \left(1 + \frac{3b_f t_f^2}{d_b d_c t_w} \right) \left(1.9 - \frac{1.2P_u}{P_y} \right) \quad (2.2-6)$$

These provisions are identical to those in LRFD Specification Equations K1-11 and K1-12, except that a lower resistance factor is used to provide an added margin against excessive panel-zone yielding. Additionally, to prevent shear buckling under the higher inelastic demand associated with high-seismic loading, the minimum thickness of the unreinforced column web given in Equation 2.2-7 is determined from AISC Seismic Provisions Section 9.3b:

$$t_w \text{ min} = \frac{d_m + d_c - 2t_f}{90} \quad (2.2-7)$$

where

- t_w = column web thickness, in.
- b_f = column flange width, in.
- t_f = column flange thickness, in.
- d_b = beam depth, in.
- d_c = column depth, in.
- F_y = column minimum specified yield strength, ksi
- P_u = column required axial strength, in.
- $P_y = F_y A$, column axial yield strength, in.
- A = column cross-sectional area, in.²
- d_m = moment arm between concentrated flange forces, in.

⁴If using allowable stress design, the shear buckling limit is slightly more conservative and the following W-shapes must be checked for shear buckling: W44×230, W40×215, W40×199, W40×183, W40×174, W40×167, W40×149, W36×150, W36×135, W33×130, W33×118, W30×99, W30×90, W27×84, W24×68, W24×55, W21×44, W18×35, W16×31, W16×26, W14×22, and W12×14.

Note that Equation 2.2-7 is in a form that has been adapted from that which appears in the AISC Seismic Provisions.

2.2.2 Local Flange Bending

When a directly welded flange or flange-plated moment connection is used, differential stiffness across the width of an unstiffened column flange results in a stress concentration in the weld adjacent to the column web as illustrated in Figure 2-5 that must be limited for tensile flange forces. The design local flange bending strength ϕR_n given in Equation 2.2-8 is determined from LRFD Specification Equation K1.1 with consideration of the proximity of the concentrated flange force to the end of the column:

$$\phi R_n = 0.9 \times 6.25t_f^2 F_y \times C_t \quad (2.2-8)$$

When an extended end-plate moment connection is used, flange bending must be limited to prevent yielding of the column flange under tensile flange forces. The design local flange bending strength ϕR_n given in Equation 2.2-9 is determined from Murray (1990) with consideration of the proximity of the concentrated flange force to the end of the column as:

$$\phi R_n = 0.9 \times \left(\frac{b_s}{\alpha_m p_e} \right) t_f^2 F_y \times C_t \quad (2.2-9)$$

where

- t_f = column flange thickness, in.
 - F_y = column specified minimum yield strength, ksi.
- Note that Equation 2.2-9 was developed from research that considered only ASTM A36 material (Curtis and Murray, 1989). If column material with higher yield strength is used, it is recommended that F_y be taken conservatively as 36 ksi in Equation 2.2-9.

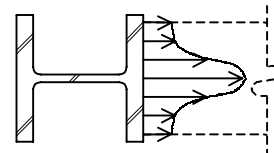

Figure 2-5 Concentration of stress in flange or flange-plate weld for a column with thin flanges and no transverse stiffeners.

- $C_t = 0.5$ if the distance from the column end to the closer face of the beam tension flange is less than $10t_f$
 $= 1$ otherwise
 $b_s = 2.5(2p_f + t_{fb})$, in., for a four-bolt unstiffened extended end plate; see Figure 2-6a
 $= 2p_f + t_{fb} + 3.5p_b$, in., for an eight-bolt stiffened extended end plate; see Figure 2-6b
 $p_f =$ distance from centerline of bolt to nearer surface of the tension flange, in; d_b plus $1/2$ in. is generally enough to provide wrench clearance; 2 in. is a common fabricator standard
 $t_{fb} =$ beam flange thickness, in.
 $p_b =$ vertical pitch of bolt group above and bolt group below tension flange, in.
 $\alpha_m = 1.36 \left(\frac{p_e}{d_b} \right)^{1/4}$ for a four-bolt unstiffened extended end plate
 $= 1.13 \left(\frac{p_e}{d_b} \right)^{1/4}$ for an eight-bolt stiffened extended end plate
 $p_e = \frac{g}{2} - \frac{d_b}{4} - k_1$
 $g =$ bolt gage, in.
 $d_b =$ bolt diameter, in.
 $k_1 =$ distance from beam web centerline to flange toe of flange-to-web fillet, in.

2.2.3 Local Web Yielding

When a directly welded flange or flange-plated moment connection is used, the concentrated force is distributed to the column web as illustrated in Figure 2-7a. The design local web yielding strength ϕR_n given in Equation 2.2-10 is determined from LRFD Specification Equations K1-2 or K1-3 with consideration of the proximity of the concentrated flange force to the end of the column:

$$\phi R_n = 1.0 \times [C_t(5k) + N]F_y t_w \quad (2.2-10)$$

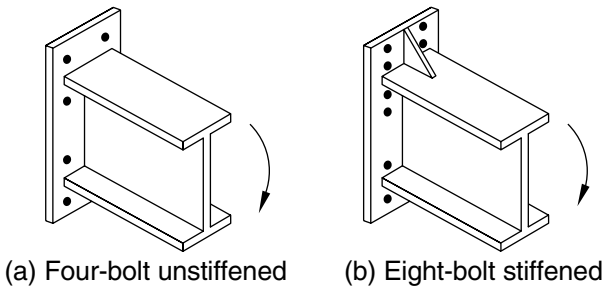

Figure 2-6 Configuration of extended end-plate moment connections.

When an extended end-plate moment connection is used, the concentrated force is distributed to the column web as illustrated in Figure 2-7b. The design local web yielding strength ϕR_n given in Equation 2.2-11 is determined from Murray (1990) with consideration of the proximity of the concentrated flange force to the end of the column:

$$\phi R_n = 1.0 \times [C_t(6k + 2t_p) + N]F_y t_w \quad (2.2-11)$$

where

- $t_w =$ column web thickness, in.
 $F_y =$ column specified minimum yield strength, ksi
 $k =$ distance from outside face of column flange to the web toe of the flange-to-web fillet, in.
 $N =$ beam flange or flange plate thickness plus $2w$, in.
 $C_t = 0.5$ if the distance from the column end to the closer face of the beam flange is less than d_c
 $= 1$ otherwise
 $w =$ leg size of fillet weld or groove weld reinforcement, if used, in.
 $t_p =$ end-plate thickness, in.
 $d_c =$ column depth, in.

2.2.4 Web Crippling

The design local web crippling strength ϕR_n given in Equation 2.2-12 is determined from LRFD Specification Equations K1-4, K1-5, or K1-6 with consideration of the proximity of the concentrated flange force to the end of the column:

$$\phi R_n = 0.75 \times 135 C_t t_w^2 \left[1 + N_d \left(\frac{t_w}{t_f} \right)^{1.5} \right] \sqrt{\frac{F_y t_f}{t_w}} \quad (2.2-12)$$

where

- $C_t = 0.5$ if the distance from the column end to the closer face of the beam compression flange is less than $d_c/2$
 $= 1$ otherwise
 $t_w =$ column web thickness, in.
 $N_d = 3N/d_c$ if the distance from the column end to the closer face of the beam tension flange is either:
 (1) greater than or equal to $d_c/2$; or,
 (2) less than $d_c/2$ and N/d_c is less than or equal to 0.2.
 $= \left(\frac{4N}{d_c} - 0.2 \right)$ otherwise
 $t_f =$ column flange thickness, in.
 $F_y =$ column specified minimum yield strength, ksi
 $N =$ beam flange or flange plate thickness plus $2w$ for directly welded flange or flange-plated moment connection, in.
 $=$ beam flange thickness plus $(2w + 2t_p)$ for extended end-plate moment connections, in.

w = leg size of fillet weld or groove weld reinforcement, if used, in.
 t_p = end-plate thickness, in.
 d_c = column depth, in.

Note that, from LRFD Specification Commentary Section K1.4, for the rolled shapes listed in ASTM A6, the limit state of web crippling will not govern the design of transverse stiffening for a moment connection, except to a W12×50 or W10×33 column. That is, if transverse stiffening is required, another limit state, such as local web yielding or local flange bending, will be more critical in all except the aforementioned two cases.

2.2.5 Compression Buckling of the Web

When a pair of compressive flange forces coincide as illustrated in Figure 2-4b, the column web is subject to out-of-plane buckling as illustrated in Figure 2-8. The design

web compression buckling strength ϕR_n given in Equation 2.2-13 is determined from LRFD Specification Equations K1-8 with consideration of the proximity of the concentrated flange force to the end of the column:

$$\phi R_n = 0.90 \times \frac{4,100 C_t t_w^3 \sqrt{F_y}}{h} \quad (2.2-13)$$

where

- $C_t = 0.5$ if the distance from the column end to the closer face of the compression flanges is less than $d_c/2$
- $= 1$ otherwise
- t_w = column web thickness, in.
- F_y = column specified minimum yield strength, ksi
- $h = d_c - 2k$, in.
- d_c = column depth, in.
- k = distance from outside face of column flange to the web toe of the flange-to-web fillet, in.

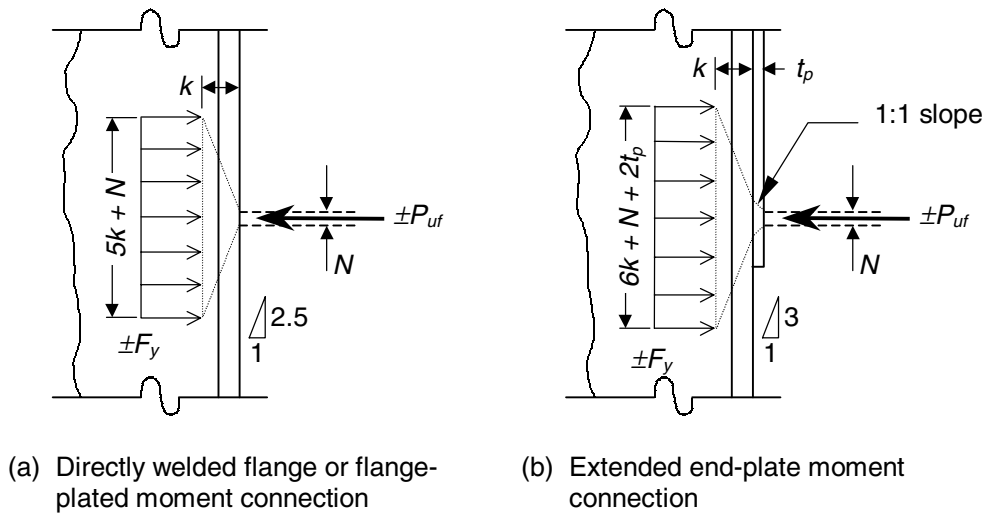

Figure 2-7 Local force transfer for local web yielding limit state.

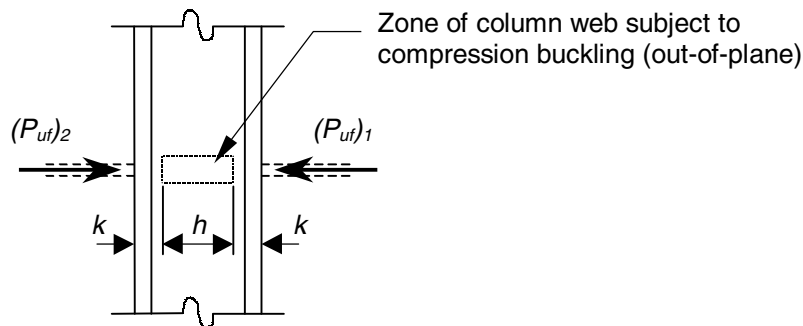

Figure 2-8 Compression buckling of the column web.

2.3 Column Cross-Sectional Stiffness Considerations

In addition to satisfying the strength requirements given in Section 2.2, the supporting column must also have sufficient stiffness to resist local deformations of the cross-section under the tensile and compressive flange forces. In wind and low-seismic applications, design for the strength criteria in Section 2.2 has historically resulted in columns with suitable stiffness as well as strength. In high-seismic applications, however, the associated higher inelastic demand necessitates a more explicit consideration of flange stiffness to limit the variation in stress distribution across the width of the connected flange or flange plate. AISC Seismic Provisions Sections 9.5 and 11.3 indicate that transverse stiffeners that match the configuration of those used in the qualifying cyclic tests (see AISC Seismic Provisions Appendix S) for the moment connection to be used are required. Note that transverse stiffeners are not required

if testing demonstrates that the intended inelastic rotation can be achieved without their use.

2.4 Design Aids

For wind and low-seismic applications, the determination of the design strength of unreinforced wide-flange shapes used as columns is simplified with the tables in Appendices A, B, and C. In Appendix A, the design column panel-zone shear strength is tabulated. In Appendix B, the design local column strength at locations of concentrated flange forces is tabulated assuming that the concentrated force is not at a column-end location. In Appendix C, the design local column strength at locations of concentrated flange forces is tabulated assuming that the concentrated force is at a column-end location. The use of these tables is illustrated in several of the example problems in Chapter 6.

Chapter 3

ECONOMICAL SELECTION OF COLUMNS

Transverse stiffeners and web doubler plates are extremely labor-intensive detail materials due primarily to the fit-up and welding that is associated with their use. Additionally, issues such as restraint, lamellar tearing and welding sequence must be addressed when transverse stiffeners and/or web doubler plates are used. As such, they add considerable cost in spite of their disproportionately low material cost. If transverse stiffeners and web doubler plates can be eliminated and an unreinforced column can be used, significant cost savings can often be realized. Additionally, the elimination of column stiffening will simplify (and thereby economize) connections that are made to the weak axis of the column.

In wind and low-seismic applications, the specification of column sizes that eliminate transverse stiffeners is encouraged. In high-seismic applications, however, transverse stiffeners will normally be required, as discussed previously in Section 2.3.

In wind, low-seismic, and high-seismic applications, the specification of column sizes that eliminate web doubler plates is encouraged. Web doubler plates require significant welding into the column flange-to-web fillet region (k-area), which is an area of potentially lower notch toughness (AISC, 1997b). The shrinkage that accompanies the cooling of these welds typically can distort the cross-section and overwelding in this region carries the potential for cracking. Additionally, the weld joint may require the use of a non-prequalified detail as discussed in Section 4.4.3.

3.1 Achieving Balance Between Increases in Material Cost and Reductions in Labor Cost

In Table 3.1, estimated costs are given for some arbitrarily selected transverse stiffener and web doubler plate details as illustrated in Figure 3-1. These estimated costs were determined by averaging the cost estimates⁵ provided by several fabricators and rounding the result to the nearest five-dollar increment. When comparing these typical details to actual details, it should be noted that the comparative weld types and sizes are of much greater significance than the thicknesses or overall dimensions of the plate materials. It is the labor involved in cutting, profiling, and

⁵The estimated costs are predicated upon the material and labor costs that existed at the time this Design Guide was written (circa early 1999). Because it is anticipated that labor costs will continue to rise at a faster rate than material costs, the user may find it advantageous to periodically inquire with local fabricators to determine a more current estimate of these costs.

welding transverse stiffeners and web doubler plates that is predominant in their cost.

An equivalent column weight change is tabulated from these estimated costs based upon a mill price of \$425 per ton, which is a median value in the common range of from \$400 to \$450 per ton FOB,^{6,7} and a 14-ft floor-to-floor height. The tabulated values are calculated as the estimated cost times 2000 lb per ton divided by \$425 per ton divided by the 14-ft length. The resulting value is the estimated maximum per-foot column-weight increase that could be made to eliminate that element of the column stiffening without increasing cost. In fact, because the tabulated values do not consider other intangible economic benefits, such as the simplification of connections that are made to the weak axis of the column, the tabulated value should be considered conservative.

As an example, consider a W14×90 column with full-depth transverse stiffeners (Case 5, Table 3.1) at each beam flange (2 pairs total) and one web doubler plate (Case 8, Table 3.1). The total of the tabulated column-weight-change values for this column stiffening arrangement is 40 lb/ft + 82 lb/ft = 122 lb/ft. Thus, if any heavier W14 up to and including a W14×211 column could be used without transverse stiffeners and a web doubler plate, it would likely be more economical than the W14×90. In most cases, the actual increase in column weight required to eliminate column stiffening will be much less than the maximum calculated and a significant economic benefit can be realized.

When the required column-weight change exceeds the sum of the tabulated values, some engineering judgment must be used. If the comparison is unfavorable, but still close, the use of a heavier column might still be justified by the aforementioned intangibles. Alternatively, the designer may still find it advantageous to investigate the possibility of eliminating the web doubler plate only (or transverse stiffeners only in some cases).

As an example, consider again the W14×90 column with full-depth transverse stiffeners (Case 5, Table 3.1) at each beam flange (two pairs total) and one web doubler plate (Case 8, Table 3.1). If any heavier W14 up to

⁶FOB stands for “free on board,” which indicates that the quoted price assumes delivery to the indicated location. In the above case, the indicated location is the mill itself; subsequent shipping would incur additional cost.

⁷Because mill prices fluctuate, the designer may find it advantageous to periodically inquire with fabricators, steel mills, or other shape suppliers to determine the current range of mill prices.

and including a W14×159 column could be used without a web doubler plate, but with the transverse stiffeners, it would be more economical than the W14×90. Similarly, if any heavier W14 up to and including a W14×120 column could be used without transverse stiffeners, but with a web doubler plate, it would be more economical than the W14×90.

3.2 Eliminating Column Stiffening

From Section 3.1, it is clear that there is significant potential for economic benefit when transverse stiffeners and web doubler plates can be eliminated. Therefore, the designer should consider alternatives that eliminate the need for column stiffening, when possible. The design aids in Appendices A, B, and C provide for the rapid identification of column strength and stiffening requirements in wind and low-seismic applications. Some additional suggestions follow.

1. Specify column material with yield strength of 50 ksi, such as ASTM A992 or A572 grade 50 steel. The increased minimum yield strength will increase

the design strength of the column, yet there will be little or no impact on the material cost. Mill grade extras for 50-ksi wide-flange material are largely nonexistent in shapes that weigh as much as 150 lb per ft of length.⁸ Even for W-shapes in weight ranges that have grade extras, these nominal cost differences of two or three pennies per pound are negligible when compared to the advantage gained in detail material savings. Column material with even higher yield strength, such as ASTM A913 grade 65 material, is also available; however, the associated material cost differential is greater.

2. Consider a different column section that has a thicker flange and/or web, as appropriate. This increase in material cost, given today's typical FOB mill price for common grades⁹ of steel of approximately \$400 to \$450 per ton, is in most cases

⁸Inquire with steel mills to determine the current range of shapes for which a grade extra applies.

⁹Common grades include ASTM A992, ASTM A572 grade 50, and A36.

Table 3.1					
Estimated Cost of Various Column Stiffening Details (as illustrated in Figure 3-1)					
Case	Thickness	Attachment to Column Flange	Attachment to Column Web	Estimated Cost	Equivalent Column Weight (lb/ft) if Wide-Flange Steel Costs \$425 per Ton from Rolling Mill ³
Partial-Depth Transverse Stiffeners (Two Pairs)					
4 PL 4½ × 0'-10 (ASTM A36) with one ¾ × ¾ corner clip each					
1	½ in.	fitted to bear	⅜-in. fillet welds	\$80	27
2	1 in.	fitted to bear	⅝-in. fillet welds	\$120	40
3	½ in.	¼-in. fillet welds	⅜-in. fillet welds	\$90	30
4	1 in.	½-in. fillet welds ¹	⅝-in. fillet welds	\$140	47
Full-Depth Transverse Stiffeners (Two Pairs)					
4 PL 4½ × 1'-0" (ASTM A36) with two ¾ × ¾ corner clips each					
5	½ in.	¼-in. fillet welds	⅜-in. fillet welds	\$120	40
6	1 in.	½-in. fillet welds	⅝-in. fillet welds	\$210	71
7	1½ in.	CJP groove weld	½-in. fillet welds ¹	\$470	158
Web Doubler Plate (One)					
1 PL 12½ × 2'-0 (ASTM A36)					
8	½ in.	CJP groove weld	⅜-in. fillet welds	\$245	82
9	¾ in.	CJP groove weld	⅝-in. fillet welds	\$370	124
10	¾ in.	⅝-in. fillet weld ²	⅝-in. fillet welds	\$215	72
11	1 in.	⅞-in. fillet weld ²	⅝-in. fillet welds	\$305	103
<p>¹The consulted fabricators were asked if they would instead prefer a CJP-groove-welded detail in place of this larger-size fillet-welded detail. In all cases, the answer was no.</p> <p>²A ¾-in. by ¾-in. bevel on the column-flange edges of the web doubler plate is used to clear the column flange-to-web fillet. It should be noted that the fillet-welded web doubler plate detail in Case 10 is not suitable for high seismic applications because the weld size does not develop the strength of the full thickness of the web doubler plate.</p> <p>³A floor-to-floor height of 14 ft has been used in this tabulation.</p>					

easily offset by the savings in labor costs, as illustrated previously in Section 3.1.

3. Consider a deeper cross-section for the beam that is connected to the column. Increasing the depth of the beam decreases the flange force delivered due to the increase in moment arm between the flange-force couple. If it were possible to replace a W16×50 with a W18×50, the material cost would not be increased; if a lighter, deeper shape were suitable, the material cost would in fact be decreased. Even if there were an increase in material cost, it would in most cases be easily offset by the savings in labor costs. Note that this suggestion may instead be punitive when the moment connection is designed to develop the strength of the beam.
4. Increase the number of moment-resisting connections and/or frames to reduce the magnitude of the moment delivered to a given connection to a level that is within the local design strength of the column section.

3.3 Minimizing the Economic Impact of Column Stiffening Requirements in Wind and Low-Seismic Applications

In some cases, the need for column stiffening may not be avoidable. When this is the case, the following suggestions may help minimize the cost impact for building structures

in wind and low-seismic applications:

1. Where allowed by governing building codes, design column stiffening in response to the actual moments and resulting flange forces rather than the full flexural strength of the cross-section; the latter simply wastes money in the majority of cases. When the Engineer of Record (EOR) delegates the determination of the column stiffening requirements, the design forces and moments should also be provided.
2. If designing in allowable stress design, take advantage of the allowable stress increase in wind-load applications (load combinations in LRFD inherently account for such concurrent occurrence of transient loads).
3. Properly address reduced design strength at column-end applications. The typical beam depth is usually such that the reduced design strength provisions for column-end applications apply only at the nearer flange force.
4. Increase the number of moment-resisting connections and/or frames to reduce the magnitude of the moment delivered to a given connection to a level that allows a more economical stiffening detail.
5. Give preference to the use of fillet welds instead of groove welds when their strength is adequate and the application is appropriate (see Chapter 4).

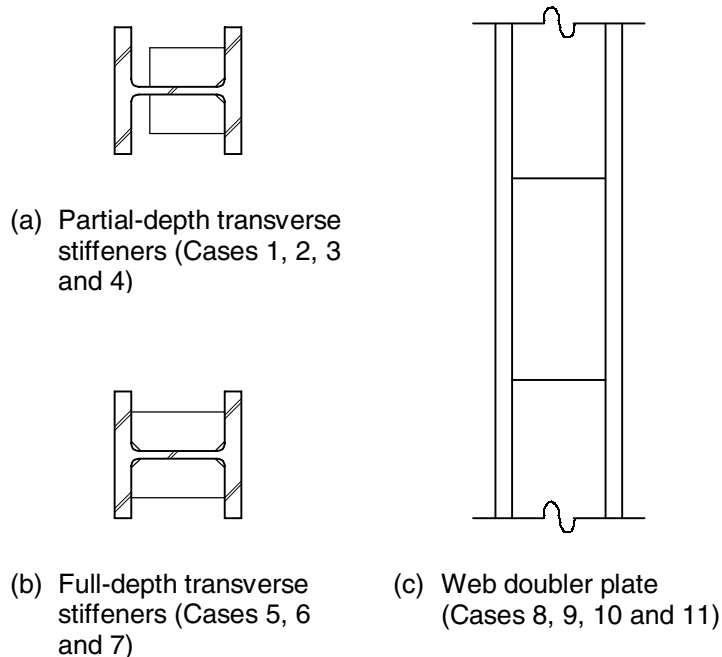

Note: dimensions and edge connections for the above column stiffening elements are as given in Table 3.1, based upon a W14 column.

Figure 3-1 Column stiffening arrangements for cost estimates in Table 3.1.

This is particularly true for the welds connecting transverse stiffeners to the column.

6. When possible, use a partial-depth transverse stiffener, which is more economical than a full-depth transverse stiffener because it need not be fitted between the column flanges. Select the partial-depth transverse stiffener length to minimize the required fillet-weld size for the transverse-stiffener-to-column-web weld.
7. While transverse stiffeners are required in pairs when the limit states of local flange bending or local web yielding are less than the required strength, a single transverse stiffener is permitted and should be considered when the limit states of web crippling and/or compression buckling of the web only are/is less than the required strength.
8. In cases when the flange force is only compressive, allow the option to weld the transverse stiffener end or to finish it to bear on the inside flange. In most lateral load resisting frames, however, moments are reversible and the design flange force may be either tensile or compressive.
9. Use a single web doubler plate up to a required thickness of $\frac{1}{2}$ in. If thicker web reinforcement is required, consider the use of two plates, one on each side of the column web. This practice may be more economical and is likely to reduce heat input, weld shrinkage, and member distortion.
10. Select the web doubler plate thickness so that plug welding between the column web and web doubler plate is not required.

11. Recognize that, in the concentrated-flange-force design provisions in LRFD Specification Section K1, it is assumed that the connection is a directly welded flange or flange-plated moment connection, not an extended end-plate moment connection. Appropriate design strength equations are given in Chapter 2 based upon the recommendations in Murray (1990).
12. Limit the number of different thicknesses that are used throughout a given project for transverse stiffeners and web doubler plates. Production economy is achieved when many repetitive elements can be used.

3.4 Minimizing the Economic Impact of Column Stiffening Requirements in High-Seismic Applications

In high-seismic applications, economy suggestions 4, 5, 6,¹⁰ 9, 10,¹¹ 11, and 12 in Section 3.3 remain applicable. Additionally, economy suggestion 1 remains applicable for web doubler plates, when the flange force(s) are determined from LRFD Specification Section A4.1, AISC Seismic Provisions Section 4.1, and Equation 2.1-1.

¹⁰Applicable when a moment connection is made to one flange only.

¹¹Note that this may not be possible in high-seismic applications if the column web thickness itself does not meet the seismic shear buckling criteria given in Equation 4.4-6.

Chapter 4

STRONG-AXIS MOMENT CONNECTIONS TO STIFFENED COLUMNS

When the required strength (Section 2.1) exceeds the design strength of the column for the concentrated forces (Section 2.2), or when the stiffness of the column cross-section is inadequate to resist the bending deformations in the column flange (Section 2.3), column stiffening is required. Several common stiffening arrangements are illustrated in Figures 4-1 through 4-6 with common welding options for the attachments of the stiffening elements to the column.

In Figures 4-1 and 4-2, a column with partial-depth transverse stiffeners only and a column with full-depth transverse stiffeners only are illustrated, respectively. In Figure 4-3, a column with web doubler plate(s) only is illustrated. In Figures 4-4, 4-5, and 4-6, columns with both transverse stiffeners and web doubler plates(s) are illustrated. In Figures 4-4 and 4-5, the web doubler plate(s)

extend past the partial-depth and full-depth transverse stiffeners, respectively. In Figure 4-6, the web doubler plate(s) extend to but not past the full-depth transverse stiffeners.

As illustrated in Figures 4-4, 4-5 and 4-6 the web doubler plates that are fillet welded to the column flanges are shown thicker than those that are groove welded to the column flanges are. This is intended to visually highlight the increased thickness that is often required to facilitate the use of a fillet-welded edge detail (see Section 4.4.2).

Fillet-welded and groove-welded details are illustrated generally in all cases. Fillet-welded details will be preferable in the majority of cases although partial-joint-penetration or complete-joint-penetration groove welds may be the best choice in some cases. Ultimately, preference should be given to the use of details that require the

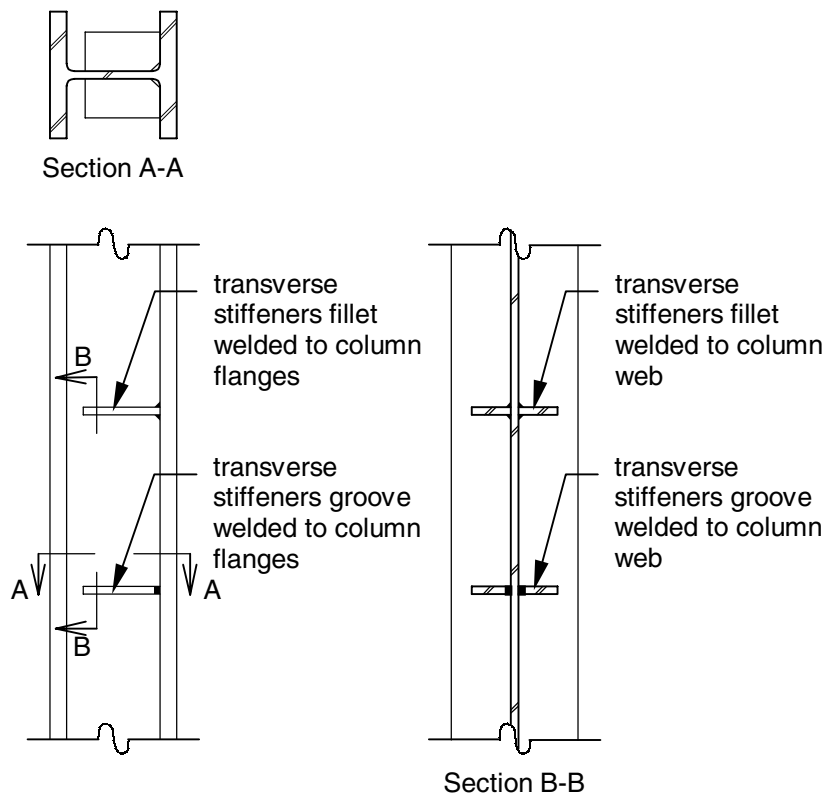

Figure 4-1 Column with partial-depth transverse stiffeners.

least amount of weld metal with due consideration of the material preparation requirements.

4.1 Determining the Column Stiffening Requirements

In wind and low-seismic applications, various alternative stiffening details utilizing transverse stiffeners, web doubler plates, or a combination thereof, are permitted in LRFD Specification Section K1, depending upon the limit state(s) for which column stiffening is required. The welding requirements are also specified for each case therein. In high-seismic applications, the required placement and welding of transverse stiffeners and web doubler plates is given in LRFD Specification Section K1 and AISC Seismic Provisions Sections 9.3c, 9.5 and 11.3. These column-stiffening requirements and alternatives are summarized in Sections 4.1.1 through 4.1.6.

4.1.1 Panel-Zone Web Shear

When the column web thickness is inadequate to resist the required panel-zone shear strength, a web doubler plate is required.¹² The welding requirements for web doubler plates are as summarized in Section 4.4.3 and 4.4.4.

4.1.2 Local Flange Bending

When the column flange thickness is inadequate to resist the tensile flange force, a pair of transverse stiffeners extending at least one-half the depth of the column web is required. They must be welded to the loaded column flange to develop the strength of the welded portion of the transverse stiffener. The weld to the column web must be sized to develop the unbalanced force in the transverse stiffener to the web.

4.1.3 Local Web Yielding

When the column web thickness is inadequate to resist the tensile or compressive flange force, either a pair of transverse stiffeners or a web doubler plate,¹³ extending at least one-half the depth of the column web is required.

In wind and low-seismic applications, when required for a tensile flange force, and in high-seismic applications, the transverse stiffener must be welded to the loaded

¹²Alternatively, diagonal stiffening can be used if it does not interfere with the weak-axis framing; see Section 5.6.

¹³See Section 5.4.

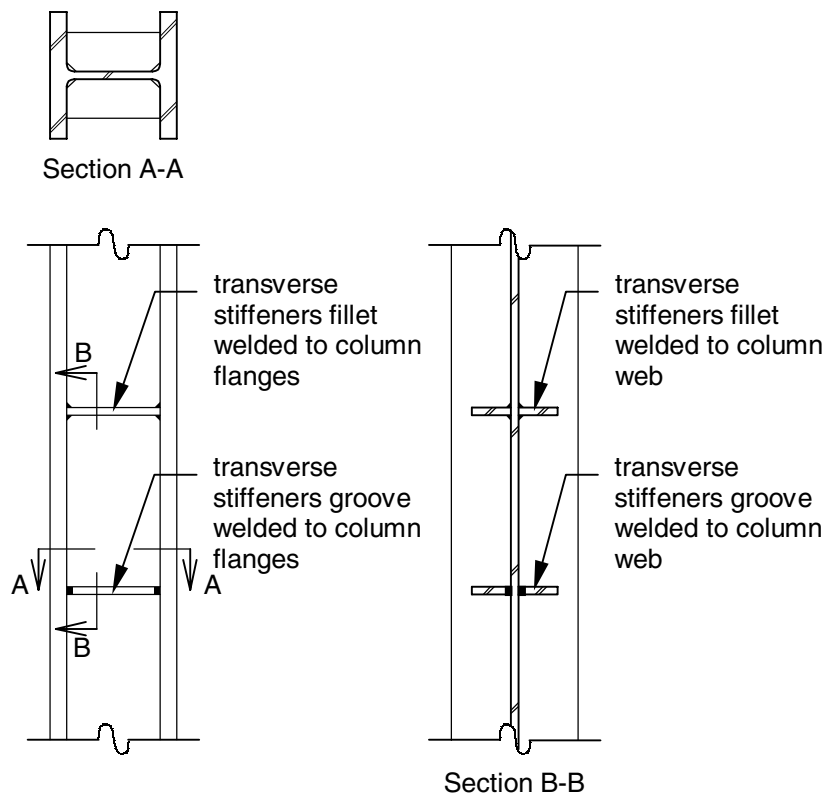

Figure 4-2 Column with full-depth transverse stiffeners.

column flange to develop the strength of the welded portion of the transverse stiffener. In wind and low-seismic applications when required for a compressive flange force, the transverse stiffener must either bear on or be welded to the loaded flange to develop the force transmitted to the transverse stiffener.

The weld to the column web must be sized to develop the unbalanced force in the transverse stiffener into the column panel-zone.

4.1.4 Web Crippling

When the column web thickness is inadequate to resist the compressive flange force, either a transverse stiffener, a pair of transverse stiffeners or a web doubler plate,¹⁴ extending at least one-half the depth of the column web, is required.

In wind and low-seismic applications, the transverse stiffener must either bear on or be welded to the loaded

flange to develop the force transmitted to the transverse stiffener. In high-seismic applications, the transverse stiffener must be welded to the loaded flange to develop the strength of the welded portion of the transverse stiffener.

The weld to the column web must be sized to develop the unbalanced force in the transverse stiffener into the column panel-zone.

4.1.5 Compression Buckling of the Web

When the column web thickness is inadequate to resist the opposing compressive flange forces, either a transverse stiffener, a pair of transverse stiffeners or a web doubler plate,¹⁵ extending the full depth of the column web, is required.

In wind and low-seismic applications, the transverse stiffener must either bear on or be welded to the loaded flange to develop the force transmitted to the transverse

¹⁴See Section 5.4.

¹⁵See Section 5.4.

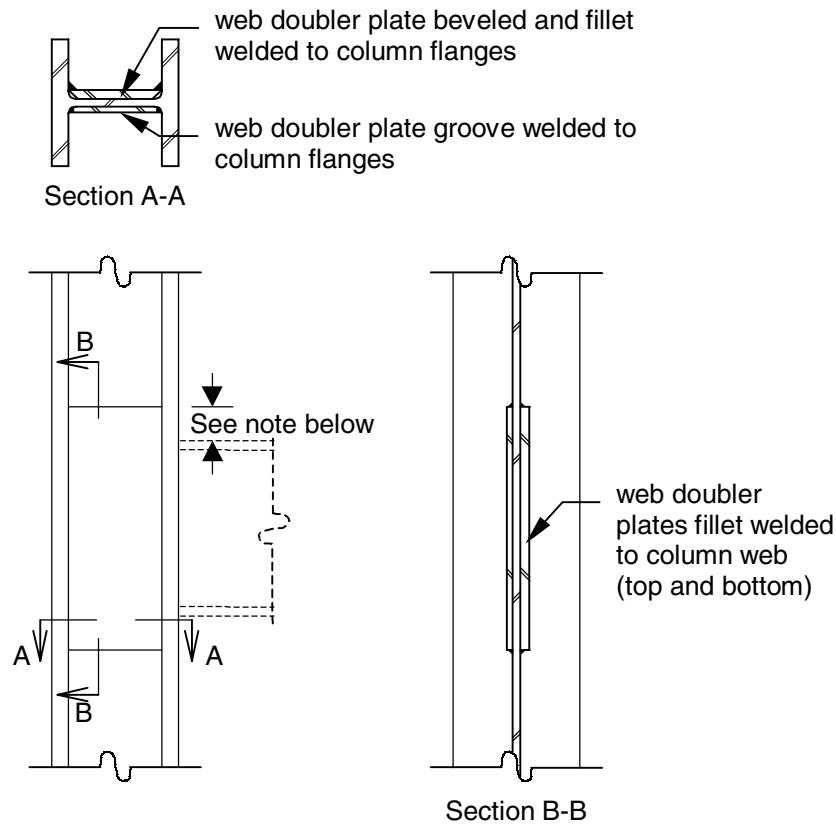

Note: $2.5k$ minimum for directly welded flange and flange-plated moment connections, $3k + t_p$ minimum for extended end-plate moment connections (top and bottom)

Figure 4-3 Column with web doubler plate(s).

stiffener. In high-seismic applications, the transverse stiffener must be welded to the loaded flange to develop the strength of the welded portion of the transverse stiffener.

The weld to the column web must be sized to develop the unbalanced force in the transverse stiffener into the column panel-zone.

4.1.6 Flange Stiffness

In wind and low-seismic applications, flange stiffness is addressed by the local flange bending limit state (Section 4.1.2). In high-seismic applications, transverse stiffeners will normally be required (see Section 2.3) in pairs with welding as described in Sections 4.3.4 and 4.3.5.

4.2 Force Transfer in Stiffened Columns

In a stiffened column, the load path is similar to that described in Section 2.1, except that the added stiffening elements share in a portion of the force transfer. Concentrated forces from the beam flanges or flange plates are

transferred locally into the column flanges. These concentrated forces spread through the column flange and flange-to-web fillet region into the web, transverse stiffener(s), if used, and web doubler plate(s), if used. Shear is dispersed between them in the column panel-zone. Ultimately, axial forces in the column flanges balance this shear.

4.2.1 Required Strength for Transverse Stiffeners

The following discussion is applicable to the required strength of the ends of the transverse stiffener in tension and/or compression. The required strength of the transverse stiffener in shear to transmit an unbalanced load to the column panel-zone is covered in Section 4.3.2.

In wind and low-seismic applications, transverse stiffeners are required only when the concentrated flange force (Section 2.1.1) exceeds the design strength of the column flange or web (Sections 2.2.2 through 2.2.5). In an exact solution, this force would be apportioned between the web and transverse stiffeners on the basis of relative

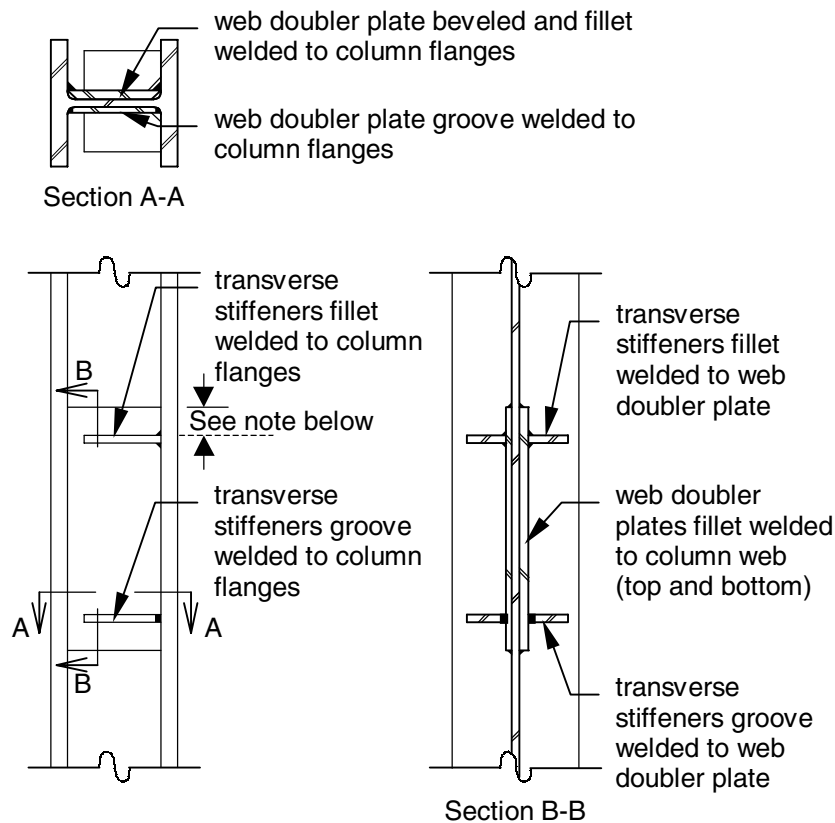

Note: $2.5k$ minimum for directly welded flange and flange-plated moment connections, $3k + t_p$ minimum for extended end-plate moment connections (top and bottom)

Figure 4-4 Column with partial-depth transverse stiffeners and web doubler plate(s) (extended).

stiffness and effective area. However, AISC has long allowed a simplified approach whereby only the force in excess of the governing column flange or web limit-state is assumed to be transmitted to the transverse stiffener end in tension or compression. Because minimum transverse stiffener width and thickness provisions are also included (see Sections 4.3.1 and 4.3.2), this rational method has historically provided a safe result. Accordingly, the required strength of the transverse stiffener(s) in tension and/or compression is:

$$R_{ust} = P_{uf} - \phi R_{n \min} \quad (4.2-1)$$

where

- P_{uf} = factored beam flange force, tensile or compressive (Section 2.1), kips
- $\phi R_{n \min}$ = the lesser of the design strengths in flange bending and web yielding at locations of tensile flange forces, or the lesser of the design strengths in local web yielding, web

crippling, and compression buckling (if applicable) at locations of compressive flange forces, kips

If R_{ust} is negative, transverse stiffening is not required and its value is set equal to zero in subsequent calculations.

Note that the flange force against which each limit state must be checked may vary. For example, the compression buckling limit-state will usually be applicable for a pair of opposing compressive flange forces induced by maximum concurrent negative moments due to gravity load at a column with beams that are moment connected to both flanges. At the same time, the tensile or compressive flange forces induced by the maximum moments due to lateral loads may be more critical for the other limit-states.

In high-seismic applications, transverse stiffeners that match the configuration of those used in the qualifying cyclic tests (AISC Seismic Provisions Appendix S) for the moment connection to be used are required as discussed previously in Section 2.3.

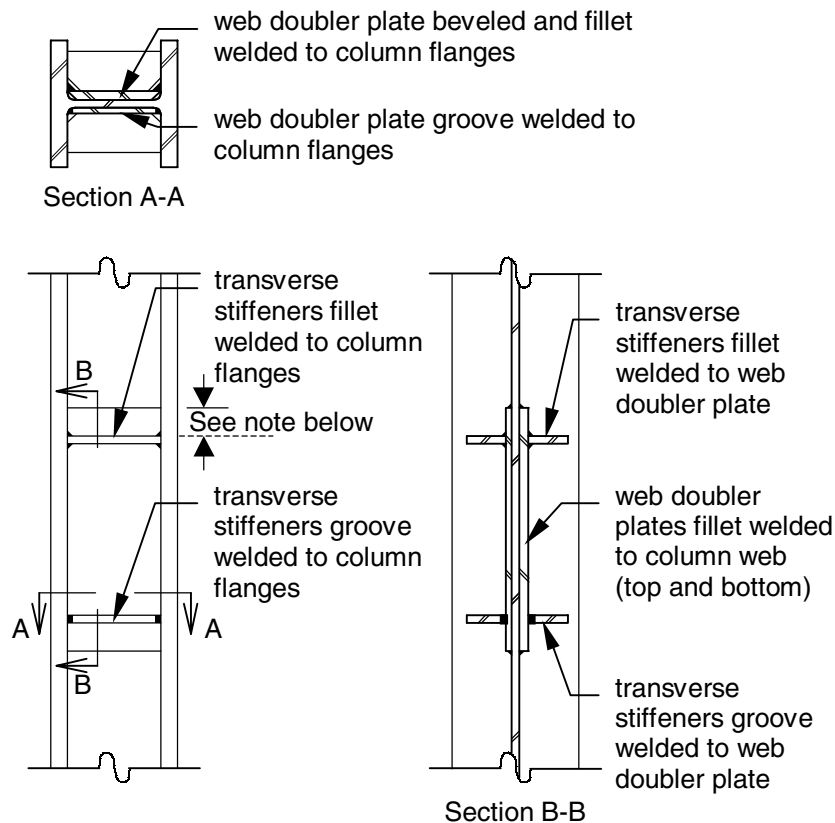

Note: 2.5k minimum for directly welded flange and flange-plated moment connections, $3k + t_p$ minimum for extended end-plate moment connections (top and bottom)

Figure 4-5 Column with full-depth transverse stiffeners and web doubler plate(s) (extended).

4.2.2 Required Strength for Web Doubler Plates

Web doubler plate(s) are required only when the column web shear (Section 2.1.2) exceeds the design strength of the column web (Section 2.2.1). The required strength of the web doubler plate(s) is:

$$V_{udp} = V_u - \phi R_{vcw} \quad (4.2-2)$$

where

V_u = factored panel-zone shear force (Section 2.1.2), kips

ϕR_{vcw} = column web design shear strength (Section 2.2.1), kips

If V_{udp} is negative, web doubler plating is not required.

4.3 Design of Transverse Stiffeners

Transverse stiffeners are sized to provide a cross-sectional area A_{st} , where

$$A_{st \min} = \frac{R_{ust}}{\phi F_{yst}} \quad (4.3-1)$$

where

R_{ust} = transverse stiffener required strength (Section 4.2.1), kips

F_{yst} = transverse stiffener specified minimum yield strength, ksi

ϕ = 0.9

When beams are moment connected to both column flanges and share transverse stiffeners, the transverse stiffener end area is selected for the maximum individual flange force, not the combined force from both transverse stiffener ends. The combined force from both transverse stiffener ends is of interest, however, for the design of the column-web edge of the transverse stiffener and may impact the required thickness; see Section 4.3.2.

4.3.1 Width of Transverse Stiffeners

In wind and low-seismic applications, from LRFD Specification Section K1.9, the minimum width of each transverse stiffener $b_{s \min}$, as illustrated in Figure 4-7, is

$$b_{s \min} = \frac{b}{3} - \frac{t_{pz}}{2} \quad (4.3-2)$$

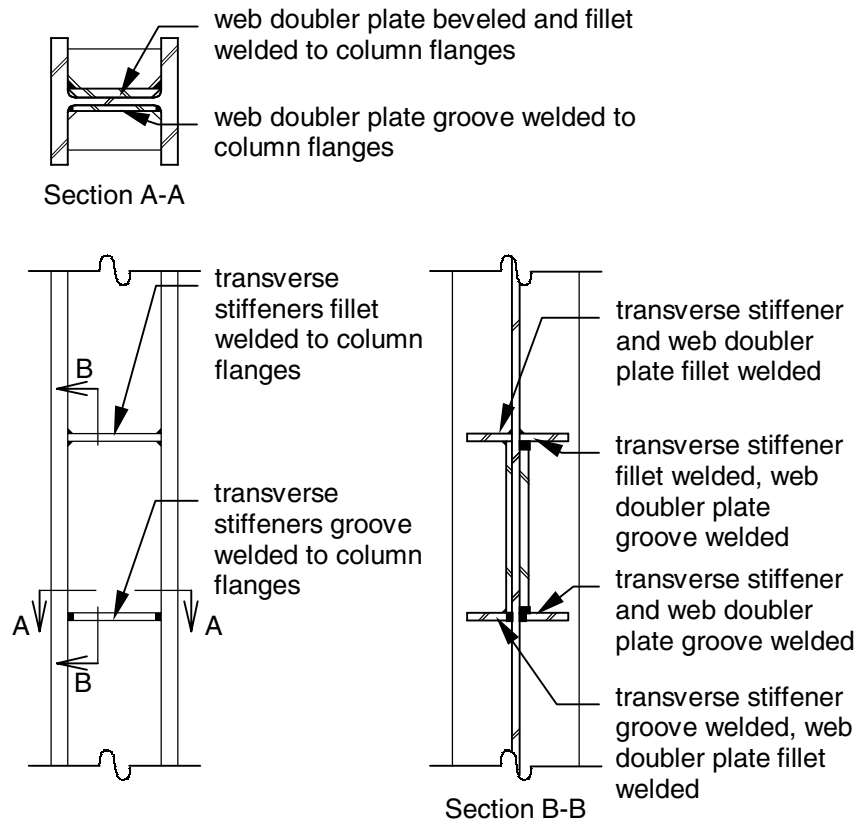

Figure 4-6 Column with full-depth transverse stiffeners and web doubler plate(s) (flush).

where

- b = width of beam flange (= b_f) or flange plate, in.
- t_{pz} = column web thickness, in., if a web doubler plate is not used or if the web doubler plate extends to (but not past) the transverse stiffeners; total panel-zone thickness, in., if the web doubler plate extends past the transverse stiffeners.

The specified width should be selected with consideration of the thickness requirements in Section 4.3.2, to satisfy the minimum area $A_{st\min}$ (Section 4.3). Area reduction due to corner clips that are required to clear the column flange-to-web fillets should be considered when sizing the transverse stiffener and its welds. As discussed in the AISC LRFD Manual (page 8-117) a $3/4$ -in. diagonal corner clip will generally be dimensionally adequate to clear most column flange-to-web fillets, but the clip dimension can be adjusted up or down as required to suit the various conditions.

In high-seismic applications, the width of each transverse stiffener should be consistent with that used in the tested assemblies (see Section 2.3). To date, qualifying cyclic tests have utilized transverse stiffeners of width such that the total stiffened width equals or slightly exceeds the beam flange or flange-plate width or such that

the transverse stiffeners extend to the full width of the column flange.

4.3.2 Thickness of Transverse Stiffeners

In wind and low-seismic applications, from LRFD Specification Section K1.9, the minimum thickness of each transverse stiffener $t_{s\min}$ when transverse stiffeners are required is:

$$t_{s\min} = \frac{t}{2} \geq \frac{b_s \sqrt{F_{yst}}}{95} \quad (4.3-3)$$

where

- t = beam flange or flange plate thickness, in.
- b_s = actual transverse stiffener width, in.

The specified thickness should be selected with consideration of the length requirements in Section 4.3.3, to satisfy the shear strength that is required to transmit the unbalanced force in the transverse stiffener to the column panel-zone. For a pair of partial-depth transverse stiffeners, the thickness required for shear strength is:

$$t_s \geq \frac{R_{ust}}{0.9 \times 0.6 F_{yst} (l - clip) \times 2} \quad (4.3-4)$$

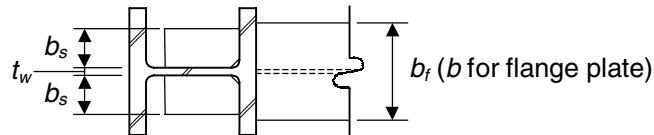

(a) Partial-depth transverse stiffeners

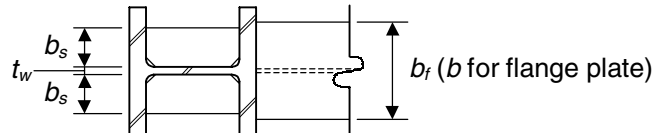

(b) Full-depth transverse stiffeners

Note: for flange-plated moment connections, use the flange-plate width b in place of the beam-flange width b_f

Figure 4-7 Illustration of transverse stiffener width b_s (wind and low-seismic applications).

For a pair of full-depth transverse stiffeners, the thickness required for shear strength is:

$$t_s \geq \frac{(R_{ust})_1 + (R_{ust})_2}{0.9 \times 0.6 F_{yst}(l - 2 \times clip) \times 2} \quad (4.3-5)$$

where

- R_{ust} = required strength of the transverse stiffener (see Section 4.2.1), kips; the subscripts 1 and 2 in Equation 4.3-5 indicate the forces at each end of the transverse stiffener
- F_{yst} = transverse stiffener specified minimum yield strength, ksi
- l = transverse stiffener length, in.
- $clip$ = transverse stiffener corner clip dimension, in.

In Equation 4.3-5, $(R_{ust})_1$ and $(R_{ust})_2$ can add, as for lateral moments, or subtract, as for gravity moments. The most critical case for transverse stiffener thickness will usually result for the case wherein they add.

In high-seismic applications, the thickness of each transverse stiffener should be consistent with that used in the tested assemblies. To date, most qualifying cyclic tests have utilized transverse stiffeners of thickness equal to that of the beam flange or flange plate to meet the recommendation of FEMA (1995).¹⁶

4.3.3 Length of Transverse Stiffeners

When full-depth transverse stiffeners are used, the length is selected for the distance between the column flanges, with due consideration of column cross-sectional tolerances and the welded joint that is to be used. When partial-depth transverse stiffeners are used, the length is selected to minimize the transverse stiffener thickness and, more importantly, the size of double-sided fillet weld that is required for the connection of the transverse stiffener to the column web; see Sections 4.3.2 and 4.3.5. Note that the minimum length for partial-depth transverse stiffeners is one-half the column depth.

4.3.4 Connecting Transverse Stiffeners to Column Flanges

In wind and low-seismic applications, when the transverse stiffener is required for a tensile flange force (due to local web yielding or local flange bending), it must be welded to develop the strength of the welded portion of the transverse stiffener. As illustrated in Figure 4-8, this can be done with double-sided fillet welds, double-sided partial-

joint penetration groove welds with fillet-weld reinforcement, or complete-joint-penetration groove welds. When using double-sided fillet welds, the weld size required is:

$$w_{\min} = \frac{0.9 F_{yst} t_s}{0.75(1.5 \times 0.6 F_{EXX})\sqrt{2}} = \frac{0.943 F_{yst} t_s}{F_{EXX}} \quad (4.3-6)$$

where

- F_{yst} = transverse stiffener specified minimum yield strength, ksi
- t_s = transverse stiffener thickness, in.
- F_{EXX} = welding electrode specified minimum strength, ksi

The 1.5 factor in the denominator of the second term in Equation 4.3-6 is the weld strength increase factor for the 90-degree angle of loading determined from LRFD Specification Appendix J2.4.

When the transverse stiffener is required for a compressive flange force only (due to local web yielding, web crippling, or compression buckling of the web), it must either bear on or be welded to the column flange to develop the force transmitted to the transverse stiffener. For proper force transfer in bearing, R_{ust} must be equal to or less than ϕR_n as given in LRFD Specification Section J8(a). From this section, it can be derived that, for a pair of transverse stiffeners, the width b_s and thickness t_s of each of the transverse stiffeners must be such that:

$$(b_s - clip)t_s \geq \frac{0.370 R_{ust}}{F_{yst}} \quad (4.3-7)$$

Alternatively, when using double-sided fillet welds, the weld size required is:

$$w_{\min} = \frac{R_{ust}}{0.75(1.5 \times 0.6 F_{EXX})(b_s - clip)(2)\sqrt{2}} \quad (4.3-8)$$

$$= \frac{0.524 R_{ust}}{F_{EXX}(b_s - clip)}$$

where

- $clip$ = transverse stiffener corner clip dimension, in.
- R_{ust} = transverse stiffener required strength (see Section 4.2.1), kips
- F_{yst} = transverse stiffener specified minimum yield, ksi
- F_{EXX} = welding electrode specified minimum strength, ksi

The 1.5 factor in the denominator of the second term in Equation 4.3-8 is the weld strength increase factor for the 90-degree angle of loading determined from LRFD Specification Appendix J2.4.

¹⁶Subsequent research (El Tawil et al., 1998) indicates that transverse stiffness with thickness equal to or greater than 60 percent of the beam flange or flange-plate thickness can provide for the required cross-sectional stiffness when a beam is moment-connected to one column flange only.

In high-seismic applications, the transverse stiffener must be welded to develop the strength of the welded portion of the transverse stiffener. As illustrated in Figure 4-8, this can be done with double-sided fillet welds, double-sided partial-joint penetration groove welds with fillet-weld reinforcement, or complete-joint-penetration groove welds. When using double-sided fillet welds, the weld size required can be determined as given previously in Equation 4.3-6.

4.3.5 Connecting Transverse Stiffeners to Column Panel-Zones

In wind, low-seismic and high-seismic applications, the transverse stiffener is welded to transmit the unbalanced force, if any, in the transverse stiffener to the column panel-zone. As illustrated in Figure 4-9b, welding to the column panel-zone is not required if the opposing beam flange forces are equal and opposite, except when compression buckling of the web governs or to stabilize the

transverse stiffeners.¹⁷ Welding to the column panel-zone will always be required when:

1. Partial-depth transverse stiffeners are used (see Figure 4-9a);
2. A beam is moment-connected to one flange of the column only; or,
3. Beams are moment-connected to both column flanges and reverse-curvature bending is anticipated (see Figure 4-9c).

The latter case is common for moment connections, especially in high-seismic applications, and results in a tensile force on one end of the transverse stiffener combined with a compressive force on the other end of the transverse stiffener. The sum of these forces is equilibrated by shear

¹⁷In such cases, minimum-size fillet welds per LRFD Specification Table J2.4 are commonly used.

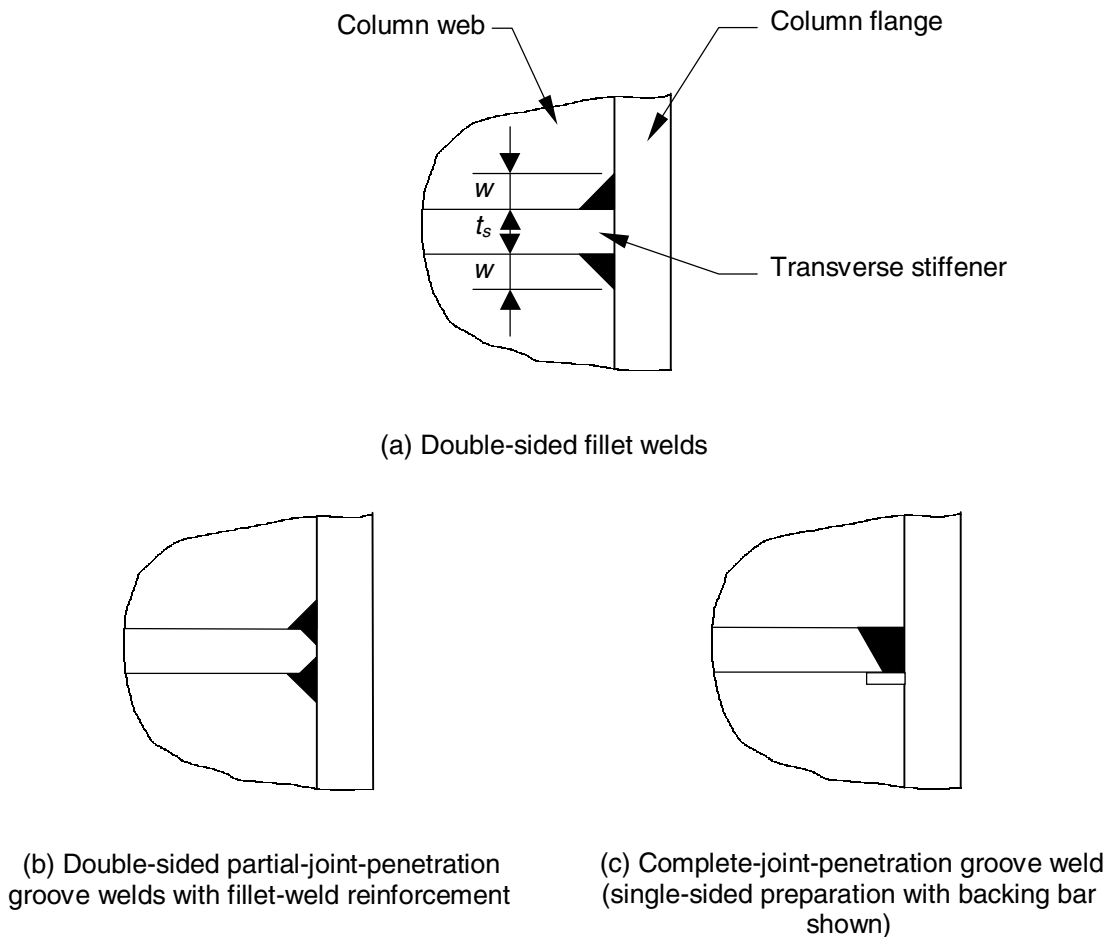

Figure 4-8 Welded joint details for transverse stiffener ends (welding to column flange).

that is distributed along the column-web edge of the transverse stiffener as illustrated in Figure 4-10.

For a pair of partial-depth transverse stiffeners, the fillet-weld size required for shear strength (with double-sided fillet welds on each transverse stiffener) is:

$$w \geq \frac{R_{ust}}{0.75 \times 0.6F_{EXX}(l - clip) \times 2 \times \sqrt{2}} \quad (4.3-9)$$

For a pair of full-depth transverse stiffeners, the fillet-weld size required for shear strength (with double-sided fillet welds on each transverse stiffener) is:

$$w \geq \frac{(R_{ust})_1 + (R_{ust})_2}{0.75 \times 0.6F_{EXX}(l - 2 \times clip) \times 2 \times \sqrt{2}} \quad (4.3-10)$$

where

R_{ust} = transverse stiffener required strength (see Section 4.2.1), kips; the subscripts 1 and 2 in Equation 4.3-10 indicate the forces at each end of the transverse stiffener as illustrated in Figure 4-10

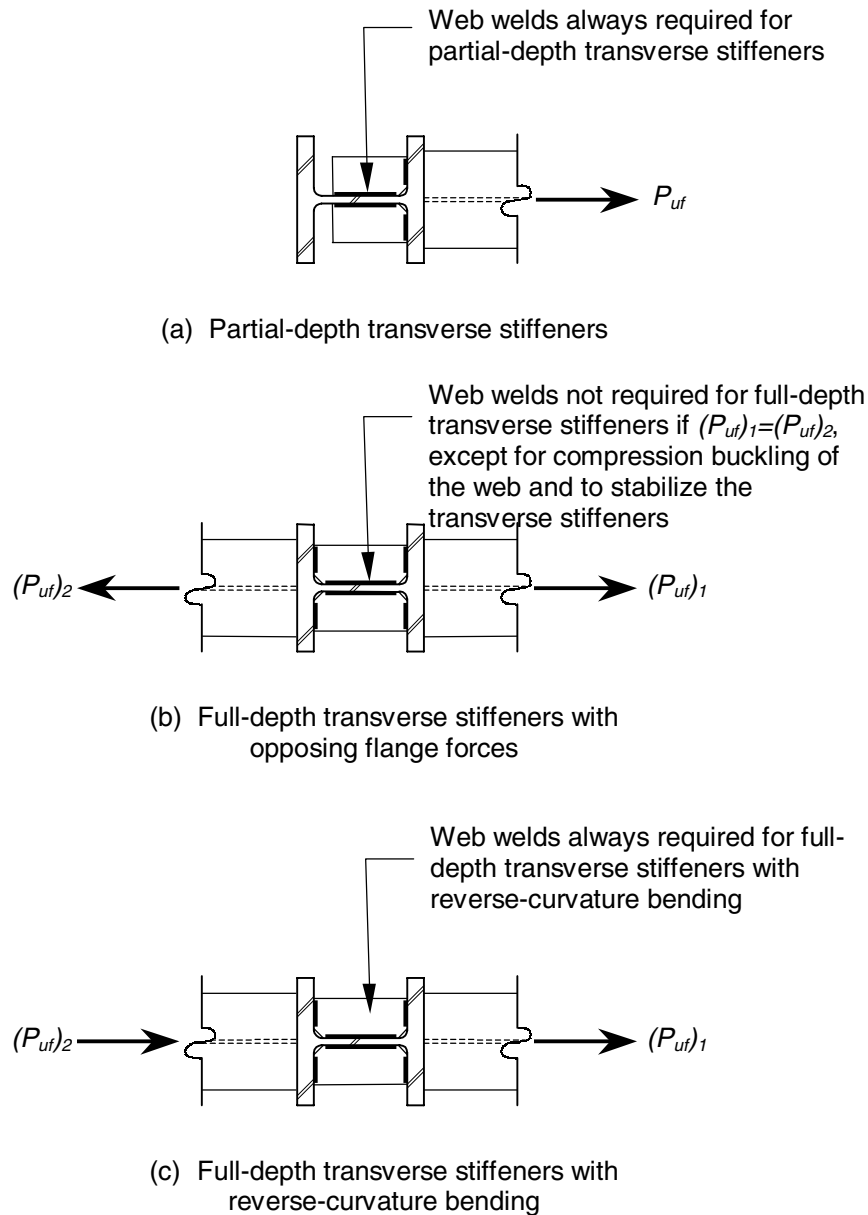

Figure 4-9 Web welding requirements for transverse stiffeners.

F_{EXX} = weld electrode specified minimum strength, ksi
 l = transverse stiffener length, in.
 $clip$ = transverse stiffener corner clip dimension, in.

In Equation 4.3-10, $(R_{ust})_1$ and $(R_{ust})_2$ can add, as for lateral moments, or subtract, as for gravity moments. The most critical case for weld size will usually result for the case wherein they add. However, the welds need not be sized to develop a force that is larger than that due to any of the following criteria:

1. The sum of the design strengths at the connections of the transverse stiffener to the column flanges (see Equations 4.3-11 and 4.3-14 or 4.3-17);
2. The design shear strength of the contact area of the transverse stiffener with the column panel-zone (see Equations 4.3-12 and 4.3-15); nor
3. The shear yield strength of the column panel-zone (see Equations 4.3-13 and 4.3-16).

Note that the second and third criteria should not govern unless the transverse stiffener was provided for stiffness rather than strength.

Thus, for a pair of partial-depth transverse stiffeners, the design shear strength of the welds ϕR_n need not exceed any of the following three forces:

$$\phi R_{n \max} = 0.9F_{yst}(2)(b_s - clip) \times t_s \quad (4.3-11)$$

$$\phi R_{n \max} = 0.9 \times 0.6F_{yst}(l - clip) \times 2t_s \quad (4.3-12)$$

$$\phi R_{n \max} = 0.9 \times 0.6F_y d_c \times t_{pz} \quad (4.3-13)$$

Similarly, for a pair of full-depth transverse stiffeners, the design shear strength of the welds ϕR_n need not exceed any of the following three forces:

$$\phi R_{n \max} = 0.9F_{yst}(4)(b_s - clip) \times t_s \quad (4.3-14)$$

$$\phi R_{n \max} = 0.9 \times 0.6F_{yst}(l - 2 \times clip) \times 2t_s \quad (4.3-15)$$

$$\phi R_{n \max} = 0.9 \times 0.6F_y d_c \times t_{pz} \quad (4.3-16)$$

where

$\phi R_{n \max}$ = maximum force for which the welds connecting the transverse stiffeners to the column panel-zone must be designed, kips

F_{yst} = transverse stiffener specified minimum yield strength, ksi

b_s = transverse stiffener width, in.

$clip$ = transverse stiffener corner clip dimension, in.

t_s = transverse stiffener thickness, in.

l = transverse stiffener length, in.

F_y = panel-zone specified minimum yield strength (column web and/or web doubler plate), in.

t_{pz} = panel-zone material thickness (column web and/or web doubler plate), in.

Note that, if a pair of full-depth transverse stiffeners is used, but a beam is moment connected to one column flange only, Equation 4.3-17 should be used in lieu of Equation 4.3-14, where:

$$\phi R_{n \max} = 0.9F_{yst}(2)(b_s - clip) \times t_s \quad (4.3-17)$$

When transverse stiffeners transmit an unbalanced load to both the column web and the web doubler plate simultaneously, the welded detail must be configured for proper force transfer from the transverse stiffener to the column web and web doubler plate. See Section 4.4.4.

4.4 Design of Web Doubler Plates

4.4.1 Width and Depth of Web Doubler Plates

In wind, low-seismic and high-seismic applications, the width and depth of web doubler plates are selected based upon the dimensions of the panel-zone, with due consideration of the details to be used to connect the web doubler plate.

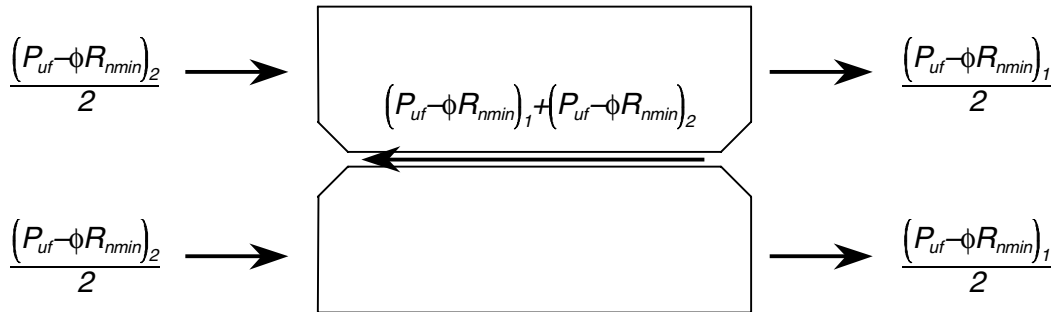

Figure 4-10 Force transfer for transverse stiffeners (reverse curvature moment case).

If full-depth transverse stiffeners are present, the web doubler plate(s) can be extended to the transverse stiffeners and one of the weld details illustrated in Figures 4-11 and 4-12 can be used. Alternatively, the web doubler plate may be extended past the transverse stiffener to clear the zone of the column web subject to crippling and buckling. As a minimum, this distance is 2.5 times the column k -distance for a directly welded flange or flange-plated moment connection and 3 times the column k -distance plus the end-plate thickness for an extended end-plate moment connection. The choice between these stiffening alternatives should be an economic one made by the fabricator with the approval of the Engineer of Record. Extending the web doubler plate past the transverse stiffener may be desirable in some cases because the top and bottom edges of the web doubler plate can be square-cut and the corners of transverse stiffeners may not need to be clipped to clear the column flange-to-web fillets.¹⁸ Additionally,

¹⁸A corner clip may still be desirable to separate and simplify the welds on the ends and edge of the transverse stiffener.

this detail may be preferable when partial-depth transverse stiffeners are used. However, if a web doubler plate is extended beyond the transverse stiffener, its thickness must be sufficient to transmit the full unbalanced force in the transverse stiffener, if any, into the panel-zone.

If transverse stiffeners are not present, the web doubler plate should extend beyond the beam flange or moment-connection flange plate to clear the zone of the column web subject to crippling and buckling. As a minimum, this distance is 2.5 times the column k -distance for a directly welded flange or flange-plated moment connection and 3 times the column k -distance plus the end-plate thickness for an extended end-plate moment connection.

4.4.2 Thickness of Web Doubler Plates

The web doubler plate thickness is selected to provide that required in excess of the column web thickness to resist panel-zone web shear. For strength, the required web doubler plate thickness is

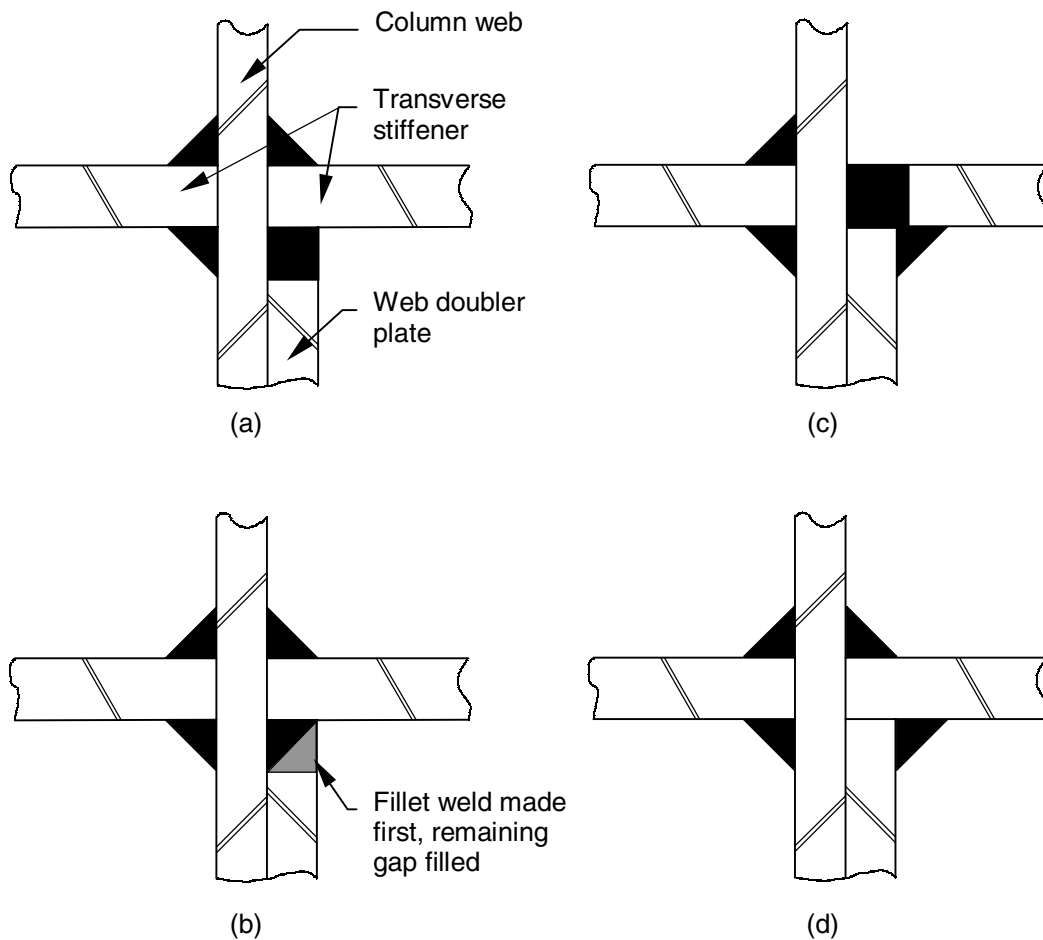

Figure 4-11 Common welded joint details at top and bottom edges with one web doubler plate and a pair of transverse stiffeners.

$$t_p \geq \frac{V_{udp}}{0.9 \times 0.6F_y d_c} \quad (4.4-1)$$

where

V_{udp} = that portion of the total panel-zone shear that is carried by the web doubler plate, kips

F_y = web doubler plate specified minimum yield strength, ksi

d_c = column depth, in.

When the web doubler plate extends past the transverse stiffener, it must be of sufficient thickness to resist the shear force that is transmitted to the column panel-zone through the transverse stiffener. For a partial-depth transverse stiffener,

$$t_{p \min} = \frac{R_{ust}}{0.9 \times 0.6F_y(l - clip) \times 4} \geq \frac{R_{ust}}{0.9 \times 0.6F_y d_c \times 2} \quad (4.4-2)$$

For a full-depth transverse stiffener,

$$t_{p \min} = \frac{(R_{ust})_1 + (R_{ust})_2}{0.9 \times 0.6F_y(l - 2 \times clip) \times 4} \geq \frac{(R_{ust})_1 + (R_{ust})_2}{0.9 \times 0.6F_y d_c \times 2} \quad (4.4-3)$$

where

R_{ust} = required strength of the transverse stiffeners (see Section 4.2.1), kips; the subscripts 1 and 2 in Equation 4.4-3 indicate the forces at each end of the transverse stiffener as illustrated in Figure 4-10

F_y = web doubler plate specified minimum yield strength, in.

l = transverse stiffener length, in.

$clip$ = transverse stiffener corner clip dimension, in.

d_c = column depth, in.

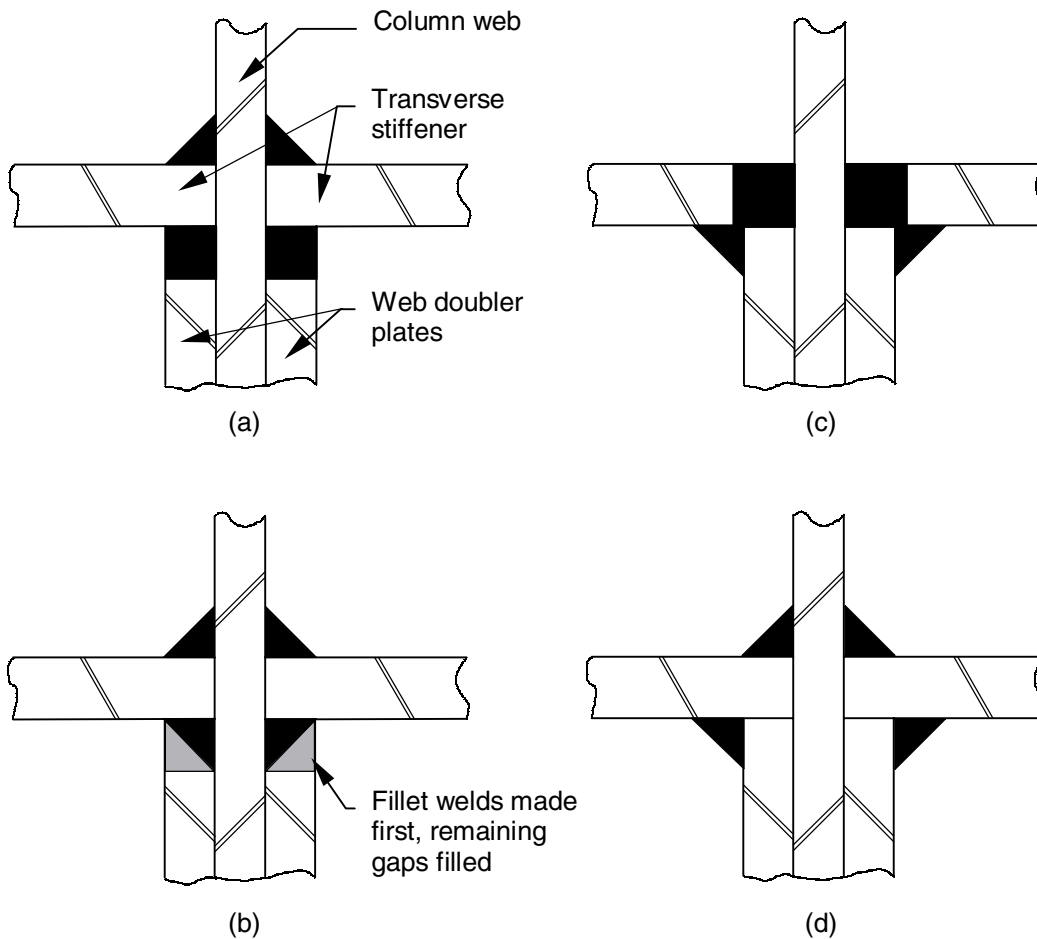

Figure 4-12 Common welded joint details at top and bottom edges with two web doubler plates and a pair of transverse stiffeners.

In Equations 4.4-2 and 4.4-3, the first term after the equal sign represents the design shear strength per in. of thickness of the web doubler plate on two shear planes with a length equal to that of the transverse stiffener fillet welds. The second term represents the design shear strength per in. of thickness of the web doubler plate on one shear plane with a length equal to the column depth. When a single web doubler plate is used, the column web thickness must also be checked using Equations 4.4-2 and 4.4-3.

When a fillet-welded edge detail is used, the minimum web doubler plate thickness $t_{p\min}$ to allow for proper beveling of the plate¹⁹ to clear the column flange-to-web fillet is:

$$t_{p\min} = r - r_e \approx k - t_f - r_e \quad (4.4-4)$$

where

- r = column flange-to-web fillet radius, which can be estimated by subtracting the flange thickness from the k -distance and rounding the result to the nearest $1/16$ -in. increment, in.
- r_e = permissible encroachment from LRFD Manual Table 9-1 (page 9-12), in.
- k = distance from outside face of column flange to the web toe of the flange-to-web fillet, in.
- t_f = column flange thickness, in.

In wind and low-seismic applications, to prevent shear buckling of the web doubler plate, the minimum thickness $t_{p\min}$ per LRFD Specification Section F2 should be:

$$t_{p\min} = \frac{h\sqrt{F_y}}{418} \quad (4.4-5)$$

Alternatively, the web doubler plate can be designed for shear buckling in accordance with LRFD Specification Appendix F2.2.

In high-seismic applications, to prevent shear buckling of the web doubler plate without the use of plug welds between the web doubler plate and the column web, the minimum thickness of both the column web and web doubler plate per AISC Seismic Provisions Section 9.3b and LRFD Specification Section F2 should be:

$$t_{\min} = \frac{d_m - t_s + d_c - 2t_f}{90} \geq \frac{h\sqrt{F_y}}{418} \quad (4.4-6)$$

where

- d_m = moment arm between concentrated flange forces, in.
- t_s = transverse stiffener thickness, in.
- d_c = column depth, in.
- t_f = column flange thickness, in.

$$h = d_c - 2k, \text{ in.}$$

$$d_c = \text{column depth, in.}$$

$$k = \text{distance from outside face of column flange to the web toe of the flange-to-web fillet, in.}$$

Alternatively, the web doubler plate and the column web can be interconnected with plug welds (see AISC Seismic Provisions Commentary Section C9.3 and Figure C-9.2) and the total thickness must satisfy the above equation.

4.4.3 Connecting Web Doubler Plates to Columns Along the Column-Flange Edges

In wind and low-seismic applications and high-seismic applications involving Ordinary Moment Frames (OMF), web doubler plates are welded along their column-flange edges to develop the required shear strength of the web doubler plate; that is, V_{udp} as used in Equation 4.4-1. In high-seismic applications involving Special Moment Frames (SMF) and Intermediate Moment Frames (IMF), web doubler plates are welded along their column-flange edges to develop the shear strength of the full web-doubler-plate thickness. Either fillet welds or groove welds can be used; see Figure 4-13. The preferred detail is usually the one that minimizes the amount of weld metal required with due consideration of the associated material preparation requirements.

It is recognized that welding in the flange-to-web fillet region of wide-flange columns carries the potential for shrinkage distortions and subsequent cracking due to restraint and low notch toughness (AISC, 1997b). This is primarily of concern for the groove-welded detail in Figure 4-13a. Nonetheless, fabricators may prefer that alternative, which can be combined with good quality and process control, inspection, and repair when necessary to maximize efficiency. As another alternative, the detail shown in AISC Seismic Provisions Commentary Figure C-9.3c with a pair of web doubler plates placed symmetrically away from the column web and used integrally with transverse stiffeners top and bottom can be used.

The use of a fillet-welded detail requires a beveled edge to clear the flange-to-web fillet radius and a web doubler plate thickness that is at least equal to the required bevel. Allowing a slight plate encroachment into the flange-to-web fillet radius, as illustrated in LRFD Manual Table 9-1 (page 9-12), reduces the required bevel and increases the net section that remains after beveling. Because the flange-to-web fillet region is a smooth transition, such slight encroachment does not normally affect fit-up. The flange-to-web fillet radius can be estimated by subtracting the flange thickness from the k -distance and rounding the result to the nearest $1/16$ -in. increment.

The reduction in plate thickness due to beveling must be considered when selecting the plate thickness (Section

¹⁹This assumes a 45-degree level.

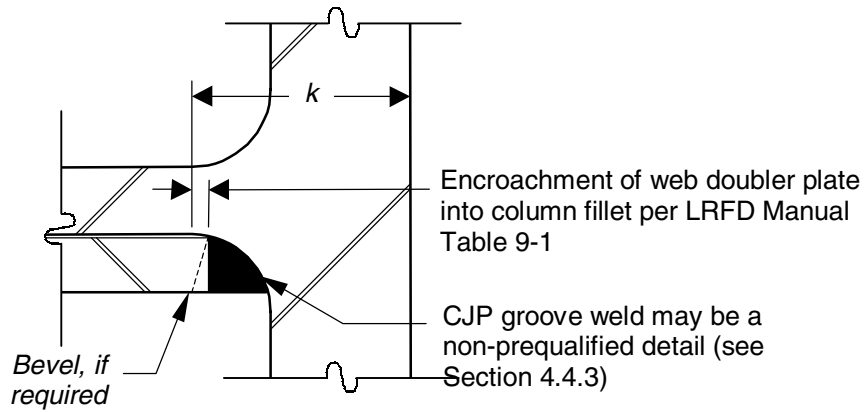

(a) CJP groove-welded detail

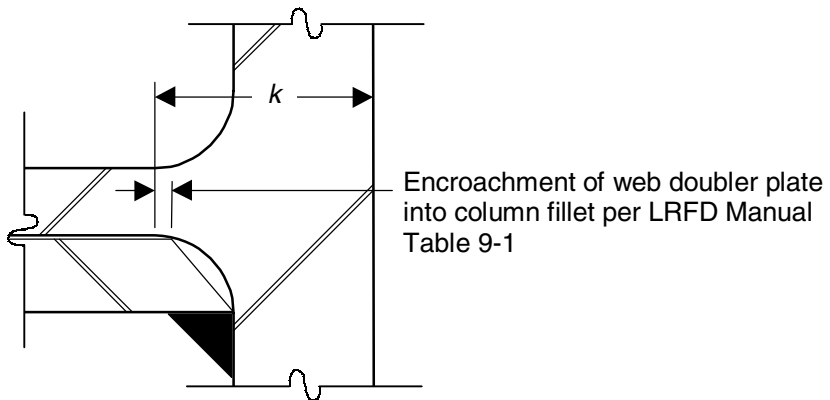

(b) Fillet-welded detail with plate bevel equal to plate thickness

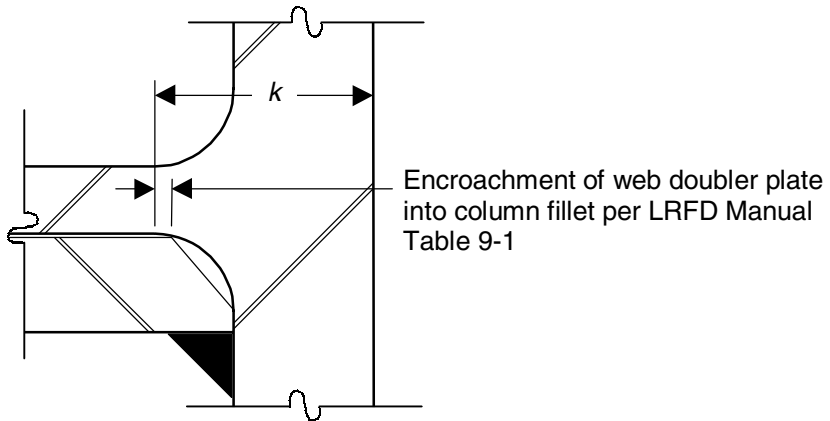

(c) Fillet-welded detail with plate bevel less than plate thickness

Figure 4-13 Common welded joint details at column-flange edges of web doubler plates.

4.4.2) and fillet-weld size. There is both a strength and geometric relationship that must be satisfied. When the bevel dimension and plate thickness are equal, as illustrated in Figure 4-13b, the minimum fillet-weld size to develop the required effective throat in the web doubler plate is:

$$\begin{aligned} w_{\min} &= \frac{0.9 \times 0.6F_y t_{\text{eff}}}{0.75 \times 0.6F_{EXX}} (\sqrt{2}) \\ &= \frac{1.70F_y t_{\text{eff}}}{F_{EXX}} \geq t_{\text{eff}} \sqrt{2} \end{aligned} \quad (4.4-7)$$

When the bevel dimension is less than the plate thickness, as illustrated in Figure 4-13c, the minimum fillet-weld size to develop the required effective throat in the web doubler plate is:

$$w_{\min} = \frac{1.70F_y t_{\text{eff}}}{F_{EXX}} \geq t_{\text{eff}} \sqrt{2} - (t_p - \text{bevel}) \quad (4.4-8)$$

where

- F_y = web doubler plate specified minimum yield strength, ksi
- t_{eff} = minimum web doubler plate thickness required for strength per Equation 4.4-1, in.
- F_{EXX} = welding electrode specified minimum strength, ksi

If a complete-joint-penetration groove weld is used, this joint is generally not an AWS prequalified weld joint, but can be successfully made with slight modification to the following AWS prequalified weld joint designations:

- (a) C-L1a or C-L1a-GF for web doubler plates that meet the thickness limitation ($1/4$ in. to $3/8$ in.) and plate edges cut square
- (b) TC-U4a (series) for plate thicknesses exceeding the qualifications of (a) with beveled plate edges

The two primary deviations from the prequalified joints are: (1) the root opening will exceed the maximum tolerance, assuming the plate width is selected to match the T -dimension of the column; and, (2) the weld throat will be slightly reduced, due to the flange-to-web fillet radius. As with a fillet weld, however, allowing a slight encroachment into the flange-to-web fillet radius reduces the shop labor required to make the weld by reducing the volume to be filled. The above practices are therefore recommended.

4.4.4 Connecting Web Doubler Plates Along the Top and Bottom Edges

When transverse stiffeners are not used and the web doubler plate is extended past the beam flange or flange plate as recommended in Section 4.4.1, there is no force to transfer

between the top and bottom edges of the web doubler plate and the column web. This is also the case when transverse stiffeners are used and the web doubler plate is extended past the transverse stiffeners as illustrated in Figures 4-4 and 4-5. In these cases, a minimum-size fillet weld per LRFD Specification Table J2.4 is used, except that the minimum size need not exceed the web doubler plate thickness minus $1/16$ -in.

When transverse stiffeners are used and the web doubler plate extends to (but not past) the transverse stiffener, the joint between the transverse stiffener, column web and web doubler plate must be detailed consistently with the load path for the unbalanced force in the transverse stiffeners. Several common details are illustrated in Figures 4-11 and 4-12. The strength checks required for each of these details are illustrated in Examples 6-13 and 6-14.

In Figures 4-11a and 4-12a, a CJP groove welded joint detail is used at the top and bottom edges of the web doubler plate(s). In Figures 4-11b and 4-12b, the joint details are essentially the same, except a fillet weld is first made connecting the transverse stiffener to the column web and the remaining gap to the web doubler plate is subsequently filled with weld metal. In each of these cases, the resulting joint can be used successfully on the thinner range of web doubler plates, say up to $3/8$ -in. thick. Beyond this thickness it is advisable to bevel the edge of the plate. Although this adds to the fabrication costs, it will benefit the welder and increase the probability of making a sound weld. In each of the details illustrated in Figures 4-11a, 4-11b, 4-12a, and 4-12b, one-quarter of the unbalanced force in the transverse stiffeners is transferred at each weld.

In Figure 4-11c, a CJP groove weld is used to connect one transverse stiffener to the column web. The web doubler plate extends to contact the transverse stiffener and is fillet welded to it. In Figure 4-12c, a similar detail is used with web doubler plates on both sides of the column web. If the column web thickness is sufficient to transmit the full unbalanced force from the transverse stiffeners (Equations 4.4-2 and 4.4-3 can be used for this check), the fillet weld between the transverse stiffener and the web doubler plate is selected as a minimum-size fillet weld per LRFD Specification Table J2.4. Otherwise, the joint detail must be configured to transmit the portion of the unbalanced force in excess of the column web strength to the web doubler plate.

In Figure 4-11d, the fillet welds on the right side connect one side of the transverse stiffener to the column web and the other side to the web doubler plate. In Figure 4-12d, a similar detail is used with web doubler plates on both sides of the column web. In each of these details, one-quarter of the unbalanced force in the transverse stiffeners is transferred at each weld.

Chapter 5

SPECIAL CONSIDERATIONS

5.1 Column Stiffening for Beams of Differing Depth and/or Top of Steel

Frequently, beams of differing depths are connected with moment connections to opposite flanges of a column at the same location as illustrated in Figure 5-1a. In other cases, the tops of steel for such beams may be offset as illustrated in Figures 5-1b and 5-1c.

For panel-zone web shear, the details illustrated in Figure 5-1 have multiple regions that must be investigated. Region 1 will be critical for reverse-curvature bending, while region 2 or 3 will be critical for opposing moments.

For local strength of the column flanges and/or web to resist the concentrated flange forces, several options exist if transverse stiffening is required. As illustrated in Figures 5-1 and 5-2a, partial-depth transverse stiffeners can be used. However, since it is generally advantageous to use as few transverse stiffeners as possible, pairs of partial-depth transverse stiffeners can be replaced with sloping full-depth transverse stiffeners as illustrated in Figure 5-2b. The design of sloping transverse stiffeners is similar to that for diagonal stiffeners. See Section 5.6.

Alternatively, it may be possible to use eccentric full-depth transverse stiffeners as illustrated in Figure 5-2c. In full-scale tests, Graham, et al. (1959) showed that transverse stiffeners with 2-in. eccentricity e provided 65 percent of the strength of identical concentric transverse stiffeners and rapidly declined in effectiveness at greater spacing. It was thus recommended that “for design purposes it would probably be advisable to neglect the resistance of stiffeners having eccentricities greater than two inches.” Otherwise, the required transverse stiffener area, width, and thickness can be established by the same criteria as for concentric transverse stiffeners, provided the strength is reduced linearly from 100 percent at zero eccentricity to 65 percent at 2-in. eccentricity.

5.2 Column Stiffening for Weak-Axis Moment Connections

In some cases, moment connections must be made for beams that frame to the webs of wide-flange columns. While the mechanics of analysis and design do not differ significantly, the details of the force transfer and connection design as well as the ductility considerations required are significantly different. Normally, the connection is configured so that the field connection is outside

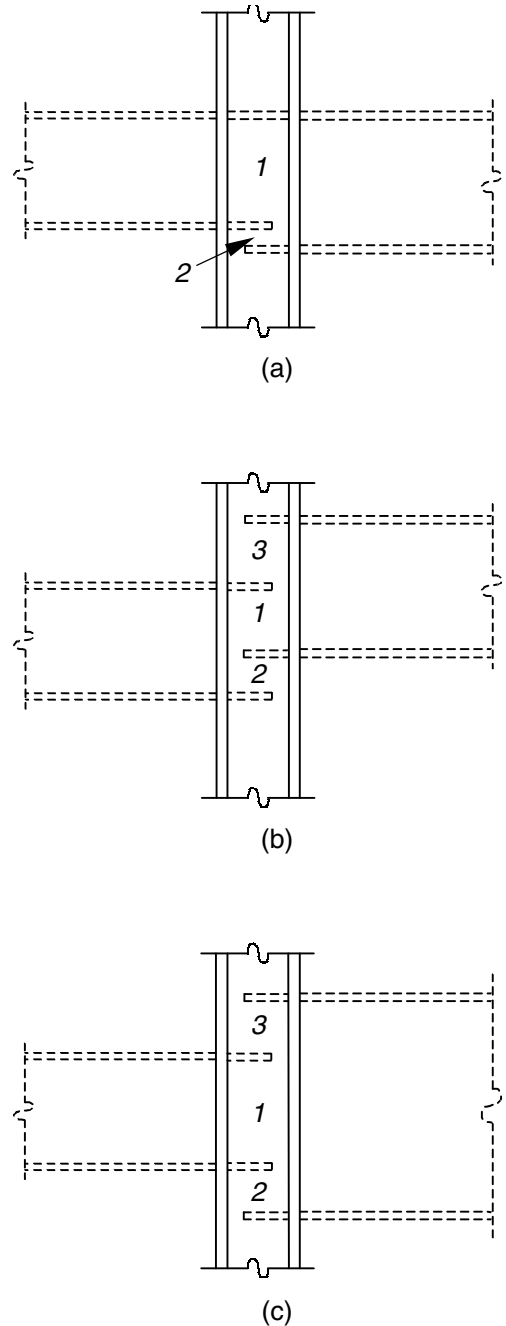
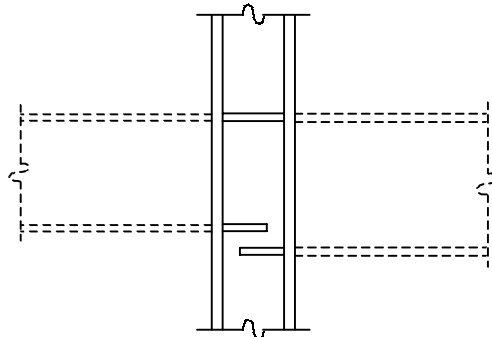
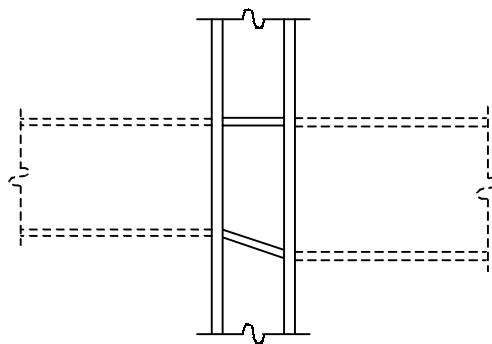

Figure 5-1 Columns with beams of differing depths and/or tops of steel.

of the column flanges. Although this requires that transverse stiffeners (or weak-axis flange connection plates in this case) be used, it greatly simplifies the erection of the beam, permits the use of an impact wrench to install all bolts, and increases accessibility and clearance for welding.



(a) Two partial-depth transverse stiffeners



(b) One sloped full-depth transverse stiffener

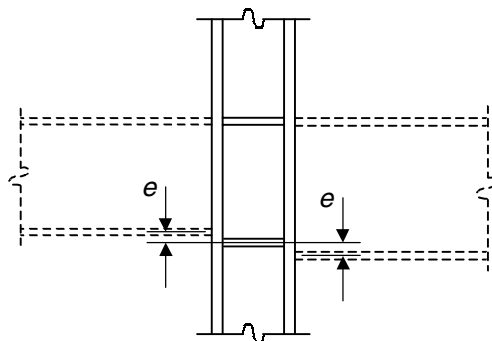

See Section 5.1 for discussion of eccentricity e .

(c) One eccentric full-depth transverse stiffener

Figure 5-2 Transverse stiffening options at flange offsets.

In wind and low-seismic applications, as indicated in LRFD Manual Part 10 (pages 10-61 through 10-65), weak-axis moment connections to wide-flange columns require special detailing to achieve an acceptable level of ductility (Driscoll and Beedle, 1982; Driscoll et al., 1983). Several recommendations are given therein for the proportioning of column stiffening and connection plates for weak-axis moment connections. Additionally, refer to Ferrell (1998). Pages 10-61 through 10-65 of the 2nd edition LRFD *Manual of Steel Construction* and the reference Ferrell (1998) have been reprinted in Appendix D for ease of reference.

In high-seismic applications, column stiffening for weak-axis moment connections must be consistent with that used in the qualifying cyclic testing.

5.3 Column Stiffening for Concurrent Strong- and Weak-Axis Moment Connections

When weak-axis framing is present, the force transfer models described in Section 4.2 and column stiffening sizing procedures described in Sections 4.3 and 4.4 must be adjusted for the additional forces induced. Additionally, the geometry of the transverse stiffeners that may also serve as weak-axis connection plates must be adjusted to provide for the required ductility as discussed in Section 5.2.

Consider the strong-axis moment connection transverse stiffeners that also serve as weak-axis moment connection plates illustrated in Figure 5-3 for a “four-way” moment connection assembly. The transverse stiffener sizing and connection to the column flanges must be selected to

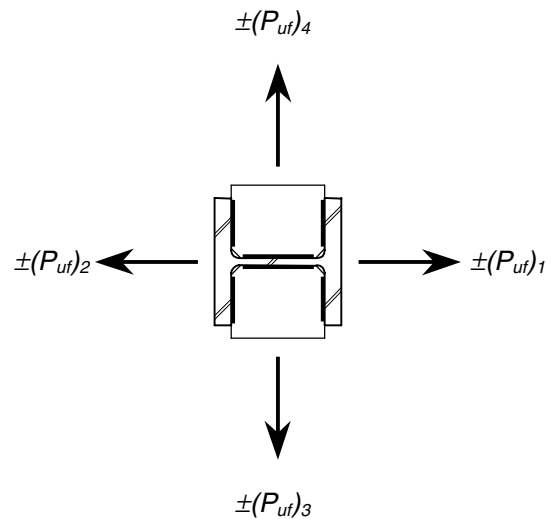

Figure 5-3 Flange forces from multiple moment connections to one column.

transfer the portion of the flange forces from the strong-axis moment connections $(P_{uf})_1$ and $(P_{uf})_2$ in excess of the column strength, as well as the flange forces from the weak-axis moment connections $(P_{uf})_3$ and $(P_{uf})_4$. The transverse stiffener connection to the column web must be selected to transfer the unbalanced force resulting from the flange forces from the strong-axis moment connections $(P_{uf})_1$ and $(P_{uf})_2$. Tamboli (1999) treats this complex subject in greater depth.

When multiple transverse stiffeners and weak-axis flange connection plates are required for beams of varying nominal depth, adequate clearance must be provided to install the transverse stiffeners. It is recommended that the vertical spacing of transverse stiffeners located on the same side of a column web be no less than three inches to ensure adequate clearance for welding. A detail such as that in Figure 5-4b may provide an economical solution. However, a more economical arrangement would likely result if the beam sizes were of similar depth as illustrated in Figure 5-4c.

In high-seismic applications, column stiffening for concurrent strong- and weak-axis moment connections must be consistent with that used in the qualifying cyclic testing.

5.4 Web Doubler Plates as Reinforcement for Local Web Yielding, Web Crippling, and/or Compression Buckling of the Web

From LRFD Specification Section K1.10, when required for local web yielding or compression buckling of the web, the thickness and extent of the web doubler plate must provide the additional panel-zone thickness necessary to equal or exceed the required strength and distribute the flange force into the column web. Additionally, the web doubler plate must be welded to develop the proportion of the total flange force that is transmitted to the web doubler plate.

5.5 Web Doubler Plates at Locations of Weak-Axis Connections

Sometimes, provision must be made for the attachment of a weak-axis connection to the web of the column through the web doubler plate. The load path illustrated in Figure 5-5 can be used when the edge connections of the web doubler plate are adequate to carry the loads (Tamboli, 1999). Otherwise, the shear from the end reaction of the supported beam must be added algebraically to the vertical shear in the web doubler plate to determine the required thickness and weld size. If the beam also were subjected to a small axial tension and/or moment, localized bending would be a major consideration in sizing the web doubler plate. If the axial tension and/or moment were significant, however, these components might better be resolved using

transverse stiffeners to transmit the forces to the column. In any case, eliminating the need for a web doubler plate through the selection of a column with a thicker web may be the most reasonable and economical alternative.

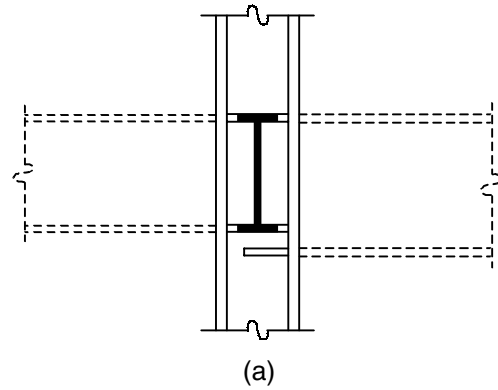

(a)

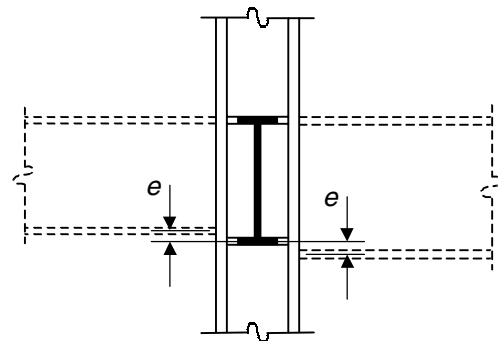

See Section 5.1 for discussion of eccentricity e .

(b)

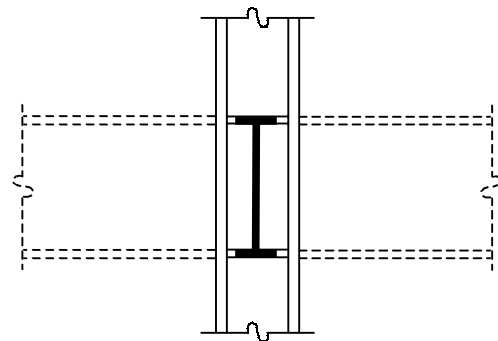

(c)

Figure 5-4 Transverse stiffening at concurrent strong- and weak-axis framing.

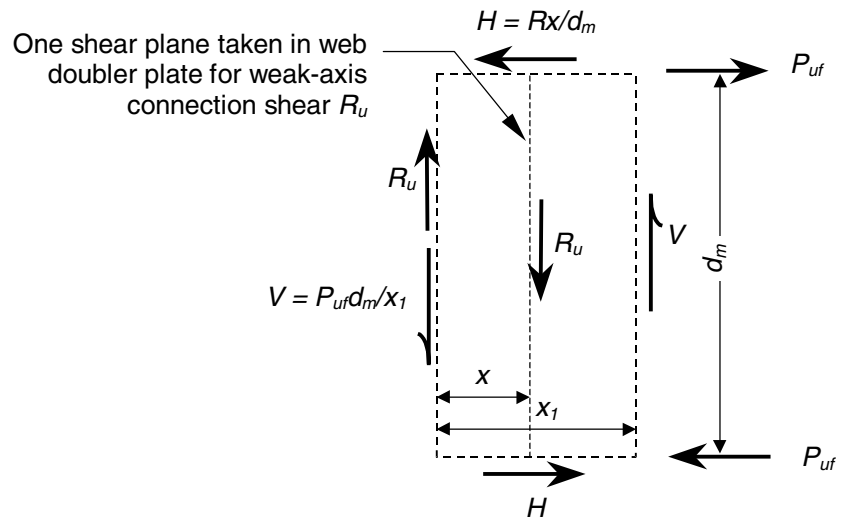
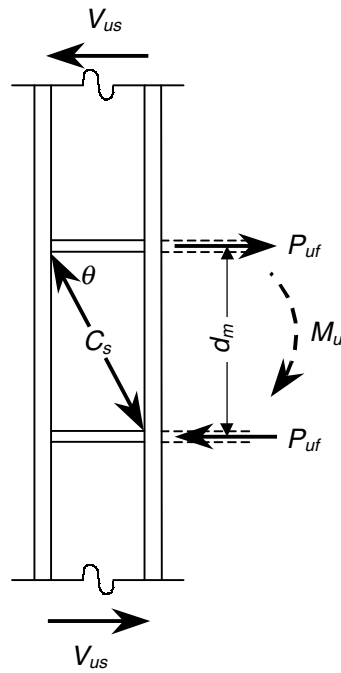

Figure 5-5 Force transfer in web doubler plate with weak-axis shear connection.



Note: beam shear and column forces not shown above for clarity.

Figure 5-6 Diagonal stiffening.

5.6 Diagonal Stiffeners

A pair of diagonal stiffeners may be used as an alternative to a web doubler plate to reinforce a column web that has inadequate design panel-zone shear strength. However, the designer should be aware of the increased fabrication costs incurred by the addition of diagonal stiffeners to a column. As with web doubler plates, it frequently is less costly to select a member with a thicker web than it is to add the diagonal stiffening.

When specified, diagonal stiffeners are sized for the strength that is required in excess of the design shear strength of the column web. The full force in the diagonal stiffener must be developed at each end, as for any truss diagonal, using either fillet welds²⁰ or groove welds. The diagonal stiffeners will prevent column web buckling with only a nominal attachment to the web.

From Figure 5-6, the combined horizontal and vertical shear forces may be resolved as a diagonal compressive stress in the column web. Thus, a diagonal stiffener may be used to “truss” the column as a compression strut.

For static equilibrium, the panel-zone shear must be resisted by shear in the column web and the horizontal component of the diagonal stiffener design strength. Thus,

$$\sum F_u = \phi R_v + P_{uf} \cos(\theta) \quad (5.6-1)$$

where, for a connection to one side of a column,

$$\sum F_u = \frac{M_u}{d_m} - V_{us} \quad (5.6-2)$$

²⁰Note that it is not always possible to use fillet welds because the root angle with diagonal stiffeners may not meet the limitations specified for fillet welds in AWS D1.1.

and the diagonal stiffener compressive force C_s is

$$C_s = \phi_c P_n = \phi_c F_{cr} A_s \quad (5.6-3)$$

Assuming $d_m = 0.9d_b$ and substituting terms,

$$\frac{M_u}{0.9d_b} - V_{us} = \phi R_v + \phi_c F_{cr} A_s \cos(\theta) \quad (5.6-4)$$

Solving for the required diagonal stiffener area,

$$A_{s \text{ req}} = \frac{1}{\cos(\theta)} \left(\frac{M_u}{(0.9d_b) \times \phi_c F_{cr}} - \frac{V_{us}}{\phi_c F_{cr}} - \frac{\phi R_v}{\phi_c F_{cr}} \right) \quad (5.6-5)$$

where

M_u = $M_{uL} + M_{uG}$, the sum of the factored moments due to lateral load and gravity load, kip-in.

d_b = beam depth, in.

$\phi_c F_{cr}$ = design compressive strength as given in LRFD Specification Section E2, kips

ϕR_v = design shear strength (see Section 2.2.1), kips

V_{us} = factored story shear due to the lateral load, kips

Letting $\phi F_{cr} = 0.85F_y$ (assumes for diagonal stiffener $Kl/r = 0$) and $\phi R_v = 0.90(0.60F_y d_c t_w)$,

$$A_{s \text{ req}} = \frac{1}{\cos(\theta)} \left(\frac{1.31M_u}{d_b F_y} - \frac{V_{us}}{0.85F_y} - 0.64t_w d_c \right) \quad (5.6-6)$$

For a more detailed treatment of diagonal stiffeners, refer to Blodgett (1967).

Chapter 6

DESIGN EXAMPLES

Example 6-1

Given:

Determine if transverse stiffeners and/or a web doubler plate will be required for the directly welded flange moment connection illustrated in Figure 6-1. The moment transferred at the connection is ± 250 ft-kips. The axial compression in the column is 300 kips. The connection is part of a frame in a wind or low-seismic application. Neglect the effects of story shear for calculation purposes.

$$\begin{aligned} &W18 \times 50, F_y = 50 \text{ ksi} \\ &d = 17.99 \text{ in.} \quad b_f = 7.495 \text{ in.} \\ &t_w = 0.355 \text{ in.} \quad t_f = 0.570 \text{ in.} \end{aligned}$$

$$\begin{aligned} &W14 \times 53, F_y = 50 \text{ ksi} \\ &d = 13.92 \text{ in.} \quad b_f = 8.060 \text{ in.} \quad k = 1\frac{7}{16} \text{ in.} \\ &k_1 = 1\frac{5}{16} \text{ in.} \quad t_w = 0.370 \text{ in.} \quad t_f = 0.660 \text{ in.} \\ &T = 11 \text{ in.} \quad A = 15.6 \text{ in.}^2 \end{aligned}$$

Solution:

Calculate the flange forces and panel-zone shear force:
From Equation 2.1-1, the force at each flange is

$$P_{uf} = \frac{M_u}{d - t_f} = \frac{250 \text{ ft-kips}(12 \text{ in./ft})}{17.99 \text{ in.} - 0.570 \text{ in.}} = 172 \text{ kips}$$

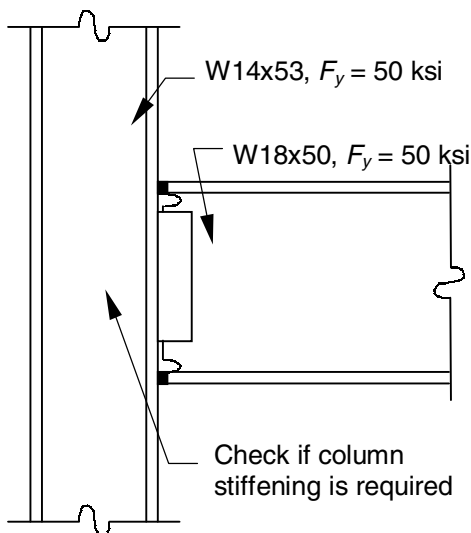

Figure 6-1 Framing arrangement for Example 6-1.

Neglecting the effects of story shear, the panel-zone web shear force is determined from Equation 2.1-5 as

$$V_u = P_{uf} = 172 \text{ kips}$$

Determine the design panel-zone web shear strength:
Assuming the behavior of the panel-zone remains nominally within the elastic range,

$$\begin{aligned} P_y &= F_y A = (50 \text{ ksi})(15.6 \text{ in.}^2) = 780 \text{ kips} \\ \frac{P_u}{P_y} &= \frac{300 \text{ kips}}{780 \text{ kips}} = 0.385 \end{aligned}$$

Since this ratio is less than 0.4, Equation 2.2-1 is applicable.

$$\begin{aligned} \phi R_v &= 0.9 \times 0.6 F_y d_c t_w \\ &= 0.9 \times 0.6(50 \text{ ksi})(13.92 \text{ in.})(0.370 \text{ in.}) \\ &= 139 \text{ kips} < V_u = 172 \text{ kips} \quad \mathbf{n.g.} \end{aligned}$$

Therefore, the web of the W14×53 is inadequate to resist the panel-zone web shear without reinforcement.

Determine the design strength of the flange and web to resist the flange forces in tension:

For a tensile flange force, the limit states of local flange bending and local web yielding must be checked. For local flange bending, from Equation 2.2-8,

$$\begin{aligned} \phi R_n &= 0.9 \times 6.25 t_f^2 F_y \times C_t \\ &= 0.9 \times 6.25(0.660 \text{ in.})^2(50 \text{ ksi}) \times 1 \\ &= 123 \text{ kips} < P_{uf} = 172 \text{ kips} \quad \mathbf{n.g.} \end{aligned}$$

For local web yielding, from Equation 2.2-10,

$$\begin{aligned} \phi R_n &= 1.0 \times [C_t(5k) + N] F_y t_w \\ &= 1.0 \times [1(5)(1\frac{7}{16} \text{ in.}) \\ &\quad + 0.570 \text{ in.}](50 \text{ ksi})(0.370 \text{ in.}) \\ &= 144 \text{ kips} < P_{uf} = 172 \text{ kips} \quad \mathbf{n.g.} \end{aligned}$$

Therefore, the flange and web of the W14×53 are inadequate to resist the tensile flange force without reinforcement.

Determine the design strength of the web to resist the flange forces in compression:

For a compressive flange force, the limit states of local web yielding, web crippling, and compression buckling

of the web must be checked. In this case, the compression buckling limit state does not apply because there is a moment connection to one flange only. For local web yielding, as determined previously,

$$\phi R_n = 144 \text{ kips} < P_{uf} = 172 \text{ kips} \quad \mathbf{n.g.}$$

For web crippling, from Equation 2.2-12,

$$N_d = \frac{3N}{d_c} = \frac{3(0.570 \text{ in.})}{13.92 \text{ in.}} = 0.123$$

$$\begin{aligned} \phi R_n &= 0.75 \times 135 C_t t_w^2 \left[1 + N_d \left(\frac{t_w}{t_f} \right)^{1.5} \right] \sqrt{\frac{F_y t_f}{t_w}} \\ &= 0.75 \times 135 (1) (0.370 \text{ in.})^2 \\ &\quad \times \left[1 + (0.123) \left(\frac{0.370 \text{ in.}}{0.660 \text{ in.}} \right)^{1.5} \right] \\ &\quad \times \sqrt{\frac{(50 \text{ ksi})(0.660 \text{ in.})}{0.370 \text{ in.}}} \\ &= 138 \text{ kips} < P_{uf} = 172 \text{ kips} \quad \mathbf{n.g.} \end{aligned}$$

Therefore, the web of the W14×53 is inadequate to resist the compressive flange force without reinforcement.

Summary:

As illustrated in Figure 6-1, the W14×53 is inadequate to resist the local forces that are induced without column stiffening. For the selection of a column that is adequate without stiffening, refer to Example 6-2. For the design of stiffening for the W14×53, refer to Example 6-3.

Comments:

The foregoing solution can be determined more expediently using the design aids in Appendices A and B. The design panel-zone web shear strength is determined from Table A-1 where, for a W14×53 with $P_u/P_y \leq 0.4$,

$$\phi R_v = 139 \text{ kips} < V_u = 172 \text{ kips} \quad \mathbf{n.g.}$$

The design strength of the flange and web to resist the flange force in tension is determined from Table B-1 where, for a W14×53, with $N = 0.570$ in. and reading from the **T** (tension) column,

$$\phi R_n = 123 \text{ kips} < P_{uf} = 172 \text{ kips} \quad \mathbf{n.g.}$$

by interpolation between the values that are tabulated for $N = 1/2$ in. and $N = 3/4$ in. The design strength of the web to resist the flange force in compression is also determined from Table B-1 where, for a W14×53, with $N = 0.570$ in. and reading from the **C** (compression) column,

$$\phi R_n = 138 \text{ kips} < P_{uf} = 172 \text{ kips} \quad \mathbf{n.g.}$$

by interpolation between the values that are tabulated for $N = 1/2$ in. and $N = 3/4$ in.

Example 6-2

Given:

For the framing arrangement given in Example 6-1, reselect the column size to eliminate the need for stiffening.

Solution:

Try a W14×74 with $F_y = 50$ ksi:

$$P_y = F_y A = (50 \text{ ksi})(21.8 \text{ in.}^2) = 1,090 \text{ kips}$$

$$\frac{P_u}{P_y} = \frac{300 \text{ kips}}{1,090 \text{ kips}} = 0.275$$

From Table A-1, with $P_u/P_y \leq 0.4$,

$$\phi R_v = 172 \text{ kips} = V_u = 172 \text{ kips} \quad \mathbf{o.k.}$$

From Table B-1, with $N = 0.570$ in.,

$$\phi R_n = 173 \text{ kips (T)} > P_{uf} = 172 \text{ kips} \quad \mathbf{o.k.}$$

$$= 189 \text{ kips (C)} > P_{uf} = 172 \text{ kips} \quad \mathbf{o.k.}$$

by interpolation between the values that are tabulated for $N = 1/2$ in. and $N = 3/4$ in.

Summary:

As illustrated in Figure 6-2, a W14×74 column ($F_y = 50$ ksi) can be used without stiffening. This column-weight increase of 21 lb/ft ($= 74 - 53$) is well within the range

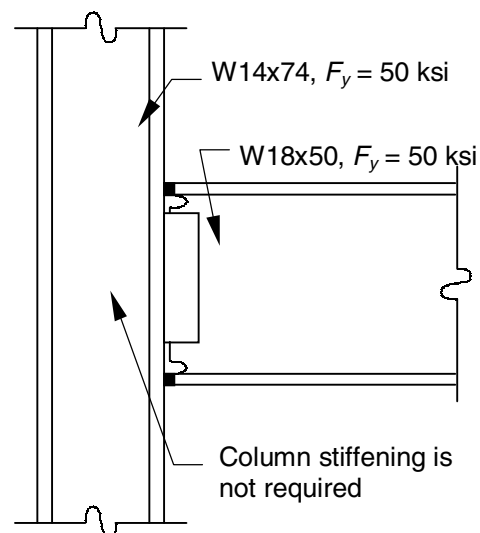

Figure 6-2 Framing arrangement for Example 6-2.

identified as economical in Chapter 3 for the elimination of two pairs of partial-depth transverse stiffeners and a web doubler plate.

Example 6-3

Given:

For the framing arrangement given in Example 6-1 (a wind or low-seismic application), design the transverse stiffeners and web doubler plate that are required to increase the local column strength of the W14×53 column. Use a stiffening detail with a pair of partial-depth transverse stiffeners at each beam flange and a web doubler plate on one side only that extends past the transverse stiffeners by $2.5k$ (nominally). Use ASTM A36 material for the stiffening elements, transverse stiffeners with fillet-welded joint details and two alternative solutions as follows:

- A) fillet-welded joint details between the web doubler plate and the column flanges and web.
- B) a groove-welded joint detail between the web doubler plate and the column flanges and a fillet-welded joint detail to the column web.

Solution A:

Calculate the transverse stiffener forces and web doubler plate shear force:

From Equation 4.2-1, the required strength for the transverse stiffeners is

$$R_{ust} = P_{uf} - \phi R_{n \min} = 172 \text{ kips} - 123 \text{ kips} = 49 \text{ kips}$$

From Equation 4.2-2, the required strength for the web doubler plate is

$$V_{udp} = V_u - \phi R_{v \text{ cw}} = 172 \text{ kips} - 139 \text{ kips} = 33 \text{ kips}$$

Check that the unbalanced load from the transverse stiffener that attaches directly to the web doubler plate is not more critical than the panel-zone web shear. For this case, the unbalanced load in one transverse stiffener is one-half of R_{ust} or 24.5 kips. Thus, the panel-zone web shear force is more critical than the unbalanced load from the transverse stiffener.

Design the web doubler plate and its associated welding:

For strength, from Equation 4.4-1,

$$t_{p \min} \geq \frac{V_{udp}}{0.9 \times 0.6 F_y d_c} \geq \frac{33 \text{ kips}}{0.9 \times 0.6 (36 \text{ ksi})(13.92 \text{ in.})}$$

$$\geq 0.122 \text{ in.}$$

Check minimum thickness required to prevent shear buckling of the web doubler plate. From Equation 4.4-5,

$$t_{p \min} = \frac{h \sqrt{F_y}}{418} = \frac{[13.92 \text{ in.} - 2(0.660 \text{ in.})] \sqrt{36 \text{ ksi}}}{418}$$

$$= 0.181 \text{ in.}$$

Check minimum thickness required to facilitate the fillet-welded joint detail between the web doubler plate and the column flange (for constructability). From Equation 4.4-4,

$$t_{p \min} = k - t_f - r_e = 1\frac{7}{16} \text{ in.} - 0.660 \text{ in.} - \frac{1}{4} \text{ in.}$$

$$= 0.528 \text{ in.}$$

The thickness required for constructability governs.

The web doubler plate width and depth are selected based upon the dimensions of the panel-zone and the edge details. Transverse to the axis of the column, the web doubler plate dimension is selected equal to the clear distance between the column flanges, which is $12\frac{9}{16}$ in. Parallel to the axis of the column, the web doubler plate dimension is selected equal to the beam depth plus two times $2.5k$, which is nominally $25\frac{1}{4}$ in.

Use PL $\frac{5}{8}$ in. \times $12\frac{9}{16}$ in. \times $2\text{'-}1\frac{1}{4}$. Note that, once the transverse stiffeners are designed, the web doubler plate will have to be checked for shear strength to carry the reaction from one transverse stiffener at each flange into the column panel-zone.

The column-flange edges are to be fillet welded. Therefore, the web doubler plate must have a $\frac{5}{8}$ -in. \times $\frac{5}{8}$ -in. bevel along each of these edges. For adequate weld and plate strength at the bevel, from Equation 4.4-7,

$$w_{\min} = \frac{1.70 F_y t_{eff}}{F_{EXX}} \geq t_{eff} \sqrt{2}$$

$$= \frac{1.70(36 \text{ ksi})(0.122 \text{ in.})}{70 \text{ ksi}} \geq (0.122 \text{ in.}) \sqrt{2}$$

$$= 0.107 \text{ in.} \geq 0.172 \text{ in.}$$

where t_{eff} is the web doubler plate thickness required for strength per Equation 4.4-1. From LRFD Specification Table J2.4, with a $\frac{5}{8}$ -in.-thick web doubler plate and 0.660-in.-thick column flange, the minimum fillet-weld size is $\frac{1}{4}$ in. **Use $\frac{1}{4}$ -in. fillet welds to connect the web doubler plate to the column flanges.**

The top and bottom edges of the web doubler plate are welded to the column web with minimum-size fillet welds per LRFD Specification Table J2.4. From LRFD Specification Table J2.4, with a $\frac{5}{8}$ -in.-thick web doubler plate and 0.370-in.-thick column web, the minimum fillet-weld size is $\frac{1}{4}$ in. **Use $\frac{1}{4}$ -in. fillet welds to connect the top and bottom edges of the web doubler plate to the column web.**

Design the transverse stiffeners and their associated welding:

From Equation 4.3-1, the minimum required cross-

sectional area for the transverse stiffeners at each flange is

$$A_{st \min} = \frac{R_{ust}}{\phi F_{yst}} = \frac{49 \text{ kips}}{0.9(36 \text{ ksi})} = 1.51 \text{ in.}^2$$

From Equation 4.3-2, the minimum width of each transverse stiffener, checking the side without the web doubler plate as the worst case, is

$$b_{s \min} = \frac{b}{3} - \frac{t_{pz}}{2} = \frac{7.495 \text{ in.}}{3} - \frac{0.370 \text{ in.}}{2} = 2.31 \text{ in.}$$

Try a pair of 3-in.-wide transverse stiffeners at each beam flange with $\frac{3}{4}$ -in. \times $\frac{3}{4}$ -in. corner clips. From Equation 4.3-3, the minimum thickness is

$$\begin{aligned} t_{s \min} &= \frac{t}{2} \geq \frac{b_s \sqrt{F_{yst}}}{95} \\ &= \frac{0.570 \text{ in.}}{2} \geq \frac{(3 \text{ in.}) \sqrt{36 \text{ ksi}}}{95} \\ &= 0.285 \text{ in.} \geq 0.189 \text{ in.} \end{aligned}$$

Try a $\frac{3}{8}$ -in. transverse stiffener thickness.

$$\begin{aligned} A_{st} &= 2(\frac{3}{8} \text{ in.})(3 \text{ in.} - \frac{3}{4} \text{ in.}) \\ &= 1.69 \text{ in.}^2 > A_{st \min} = 1.51 \text{ in.}^2 \quad \mathbf{o.k.} \end{aligned}$$

The double-sided fillet welds connecting the transverse stiffeners to the column flanges are sized to develop the strength of the welded portion of the transverse stiffener. From Equation 4.3-6, the weld size required for strength is

$$\begin{aligned} w_{\min} &= \frac{0.943 F_{yst} t_s}{F_{EXX}} = \frac{0.943(36 \text{ ksi})(\frac{3}{8} \text{ in.})}{70 \text{ ksi}} \\ &= 0.182 \text{ in.} \sim \frac{3}{16} \text{ in.} \end{aligned}$$

From LRFD Specification Table J2.4, with a $\frac{3}{8}$ -in.-thick transverse stiffener and 0.660-in.-thick column flange, the minimum weld size is $\frac{1}{4}$ in. **Use $\frac{1}{4}$ -in. double-sided fillet welds to connect the transverse stiffeners to the column flange.**

The length of the transverse stiffeners and the double-sided fillet welds connecting them to the column web or web doubler plate are selected to transmit the force in the transverse stiffener and minimize the required fillet weld size. From LRFD Specification Table J2.4, with a $\frac{3}{8}$ -in.-thick transverse stiffener, $\frac{5}{8}$ -in.-thick web doubler plate and 0.370-in.-thick column web, the minimum weld size is $\frac{1}{4}$ in. Try $\frac{1}{4}$ -in. fillet welds.

For shear strength in the transverse stiffener, using a rearranged form of Equation 4.3-4,

$$\begin{aligned} l_{\min} &= \frac{R_{ust}}{0.9 \times 0.6 F_{yst} t_s \times 2} + clip \\ &= \frac{49 \text{ kips}}{0.9 \times 0.6(36 \text{ ksi})(\frac{3}{8} \text{ in.}) \times 2} + \frac{3}{4} \text{ in.} = 4.11 \text{ in.} \end{aligned}$$

For weld shear strength with $\frac{1}{4}$ -in. fillet welds, using a rearranged form of Equation 4.3-9,

$$\begin{aligned} l_{\min} &= \frac{R_{ust}}{0.75 \times 0.6 F_{EXX} w \times 2 \times \sqrt{2}} + clip \\ &= \frac{49 \text{ kips}}{0.75 \times 0.6(70 \text{ ksi})(\frac{1}{4} \text{ in.}) \times 2 \times \sqrt{2}} + \frac{3}{4} \text{ in.} \\ &= 2.95 \text{ in.} \end{aligned}$$

For shear strength in the column web and web doubler plate with each element checked against one-half of R_{ust} , the 0.370-in.-thick column web with $F_y = 50$ ksi is more critical than the $\frac{5}{8}$ -in.-thick web doubler plate with $F_y = 36$ ksi. Using a rearranged form of the first term after the equal sign in Equation 4.4-2,

$$\begin{aligned} l_{\min} &= \frac{R_{ust}}{4(0.9 \times 0.6 F_{yt})} + clip \\ &= \frac{49 \text{ kips}}{4[0.9 \times 0.6(50 \text{ ksi})(0.370 \text{ in.})]} + \frac{3}{4} \text{ in.} \\ &= 1.23 \text{ in.} \end{aligned}$$

Checking the second term after the equal sign in Equation 4.4-2,

$$\begin{aligned} t_{\min} &= \frac{R_{ust}}{0.9 \times 0.6 F_y d_c \times 2} \\ &= \frac{49 \text{ kips}}{0.9 \times 0.6(50 \text{ ksi})(13.92 \text{ in.}) \times 2} \\ &= 0.0652 \text{ in.} < t_w = 0.370 \text{ in.} \quad \mathbf{o.k.} \end{aligned}$$

The minimum transverse stiffener length, from LRFD Specification Section K1 (as summarized in Sections 4.1.2 through 4.1.5), is

$$\begin{aligned} l_{\min} &= \frac{d - 2t_f}{2} = \frac{13.92 \text{ in.} - 2(0.660 \text{ in.})}{2} \\ &= 6.30 \text{ in.} \quad \mathbf{governs} \end{aligned}$$

Use 2 PL $\frac{3}{8}$ -in. \times 3 in. \times 0'-6 $\frac{1}{2}$ with one $\frac{3}{4}$ -in. \times $\frac{3}{4}$ -in. corner clip each and $\frac{1}{4}$ -in. double-sided fillet welds to connect the transverse stiffeners to the column web and web doubler plate.

Solution B:

Calculate the transverse stiffener forces and web doubler plate shear force:

From Solution A,

$$R_{ust} = 49 \text{ kips}$$

$$V_{udp} = 33 \text{ kips}$$

Design the web doubler plate and its associated welding:
For strength, from Equation 4.4-1,

$$t_p \geq \frac{V_{udp}}{0.9 \times 0.6 F_y d_c} \geq \frac{33 \text{ kips}}{0.9 \times 0.6 (36 \text{ ksi})(13.92 \text{ in.})}$$

$$\geq 0.122 \text{ in.}$$

Check minimum thickness required to prevent shear buckling of the web doubler plate. From Equation 4.4-5,

$$t_{p \min} = \frac{h \sqrt{F_y}}{418} = \frac{[13.92 \text{ in.} - 2(0.660 \text{ in.})] \sqrt{36 \text{ ksi}}}{418}$$

$$= 0.181 \text{ in.}$$

The thickness required to prevent shear buckling of the web doubler plate governs.

The web doubler plate width and depth are selected based upon the dimensions of the panel-zone and the edge details. Transverse to the axis of the column, the web doubler plate dimension is selected equal to the T-dimension of the column, plus twice the permissible encroachment from LRFD Manual Table 9-1 (page 9-12), which is 11 in. + 2(1/4 in.) = 11 1/2 in. Parallel to the axis of the column, the web doubler plate dimension is selected equal to the beam depth plus two times 2.5k, which is nominally 25 1/4 in.

Use **PL 1/4 in. × 11 1/2 in. × 2'-1 1/4**. Note that, once the transverse stiffeners are designed, the web doubler plate will have to be checked for shear strength to carry the reaction from one transverse stiffener at each flange into the column panel-zone.

The column-flange edges are to be CJP groove welded. Use **1/4-in. CJP groove welds to connect the web doubler plate to the column flanges.**

The top and bottom edges of the web doubler plate are welded to the column web with minimum-size fillet welds per LRFD Specification Table J2.4. From LRFD Specification Table J2.4, with a 1/4-in.-thick web doubler plate and 0.370-in.-thick column web, the minimum fillet-weld size is 3/16 in. Use **3/16-in. fillet welds to connect the top and bottom edges of the web doubler plate to the column web.**

Design the transverse stiffeners and their associated welding:

From Equation 4.3-1, the minimum required cross-sectional area for the transverse stiffeners at each flange is

$$A_{st \min} = \frac{R_{ust}}{\phi F_{yst}} = \frac{49 \text{ kips}}{0.9(36 \text{ ksi})} = 1.51 \text{ in.}^2$$

From Equation 4.3-2, the minimum width of each transverse stiffener, checking the side without the web doubler plate as the worst case, is

$$b_{s \min} = \frac{b}{3} - \frac{t_{pz}}{2} = \frac{7.495 \text{ in.}}{3} - \frac{0.370 \text{ in.}}{2} = 2.31 \text{ in.}$$

Try a pair of 3-in.-wide transverse stiffeners at each beam flange with 3/4-in. × 3/4-in. corner clips. From Equation 4.3-3, the minimum thickness is

$$t_{s \min} = \frac{t}{2} \geq \frac{b_s \sqrt{F_{yst}}}{95}$$

$$= \frac{0.570 \text{ in.}}{2} \geq \frac{(3 \text{ in.}) \sqrt{36 \text{ ksi}}}{95}$$

$$= 0.285 \text{ in.} \geq 0.189 \text{ in.}$$

Try a 3/8-in. transverse stiffener thickness.

$$A_{st} = 2(3/8 \text{ in.})(3 \text{ in.} - 3/4 \text{ in.})$$

$$= 1.69 \text{ in.}^2 > A_{st \min} = 1.51 \text{ in.}^2 \quad \text{o.k.}$$

The double-sided fillet welds connecting the transverse stiffeners to the column flanges are sized to develop the strength of the welded portion of the transverse stiffener. From Equation 4.3-6, the weld size required for strength is

$$w_{\min} = \frac{0.943 F_{yst} t_s}{F_{EXX}} = \frac{0.943(36 \text{ ksi})(3/8 \text{ in.})}{70 \text{ ksi}}$$

$$= 0.182 \text{ in.} \sim 3/16 \text{ in.}$$

From LRFD Specification Table J2.4, with a 3/8-in.-thick transverse stiffener and 0.660-in.-thick column flange, the minimum weld size is 1/4 in. Use **1/4-in. double-sided fillet welds to connect the transverse stiffeners to the column flange.**

The length of the transverse stiffeners and the double-sided fillet welds connecting them to the column web or web doubler plate are selected to transmit the force in the transverse stiffener and minimize the required fillet weld size. From LRFD Specification Table J2.4, with a 3/8-in.-thick transverse stiffener, 1/4-in.-thick web doubler plate and 0.370-in.-thick column web, the minimum weld size is 3/16-in. Try 3/16-in. fillet welds.

For shear strength in the transverse stiffener, using a rearranged form of Equation 4.3-4,

$$l_{\min} = \frac{R_{ust}}{0.9 \times 0.6 F_{yst} t_s \times 2} + clip$$

$$= \frac{49 \text{ kips}}{0.9 \times 0.6(36 \text{ ksi})(3/8 \text{ in.}) \times 2} + 3/4 \text{ in.} = 4.11 \text{ in.}$$

For weld shear strength with 3/16-in. fillet welds, using a rearranged form of Equation 4.3-9,

$$l_{\min} = \frac{R_{ust}}{0.75 \times 0.6 F_{EXX} w \times 2 \times \sqrt{2}} + clip$$

$$= \frac{49 \text{ kips}}{0.75 \times 0.6(70 \text{ ksi})(3/16 \text{ in.}) \times 2 \times \sqrt{2}} + 3/4 \text{ in.}$$

$$= 3.68 \text{ in.}$$

For shear strength in the column web and web doubler plate with each element checked against one-half of R_{ust} , the $1/4$ -in.-thick web doubler plate with $F_y = 36$ ksi is more critical than the 0.370-in.-thick column web with $F_y = 50$ ksi. Using a rearranged form of the first term after the equal sign in Equation 4.4-2,

$$l_{\min} = \frac{R_{ust}}{4(0.9 \times 0.6F_y t)} + clip$$

$$= \frac{49 \text{ kips}}{4[0.9 \times 0.6(36 \text{ ksi})(1/4 \text{ in.})]} + 3/4 \text{ in.} = 3.27 \text{ in.}$$

Checking the second term after the equal sign in Equation 4.4-2,

$$t_{\min} = \frac{R_{ust}}{0.9 \times 0.6F_y d_c \times 2}$$

$$= \frac{49 \text{ kips}}{0.9 \times 0.6(36 \text{ ksi})(13.92 \text{ in.}) \times 2}$$

$$= 0.0905 \text{ in.} < t_p = 1/4 \text{ in.} \quad \mathbf{o.k.}$$

The minimum transverse stiffener length, from LRFD Specification Section K1 (as summarized in Sections 4.1.2 through 4.1.5), is

$$l_{\min} = \frac{d - 2t_f}{2} = \frac{13.92 \text{ in.} - 2(0.660 \text{ in.})}{2}$$

$$= 6.30 \text{ in.} \quad \mathbf{governs}$$

Use 2 PL $3/8$ -in. \times 3 in. \times 0'-6 $1/2$ with one $3/4$ -in. \times $3/4$ -in. corner clip each and $3/16$ -in. double-sided fillet welds

to connect the transverse stiffeners to the column web and web doubler plate.

Summary A:

The use of a W14 \times 53 column requires the use of a web doubler plate and a pair of transverse stiffeners at the location of each beam flange. The web doubler plate required is a PL $5/8$ in. \times 12 $9/16$ in. \times 2'-1 $1/4$ with $5/8$ -in. \times $5/8$ -in. bevels on the column-flange edges. It is welded to the column flanges along the column-flange edges and to the column web along the top and bottom edges with $1/4$ -in. single-sided fillet welds. The partial-depth transverse stiffeners required are 4 PL $3/8$ -in. \times 3 in. \times 0'-6 $1/2$ with one $3/4$ -in. \times $3/4$ -in. corner clip each. Each transverse stiffener is welded to the column flange and the column web or web doubler plate with $1/4$ -in. double-sided fillet welds. This column-stiffening configuration is illustrated in Figure 6-3.

Summary B:

The use of a W14 \times 53 column requires the use of a web doubler plate and a pair of transverse stiffeners at the location of each beam flange. The web doubler plate required is a PL $1/4$ in. \times 11 $1/2$ in. \times 2'-1 $1/4$. It is welded to the column flanges along the column-flange edges with $1/4$ -in. CJP groove welds and to the column web along the top and bottom edges with $3/16$ -in. single-sided fillet welds. The partial-depth transverse stiffeners required are 4 PL $3/8$ -in. \times 3 in. \times 0'-6 $1/2$ with one $3/4$ -in. \times $3/4$ -in. corner clip each. Each transverse stiffener is welded to the column

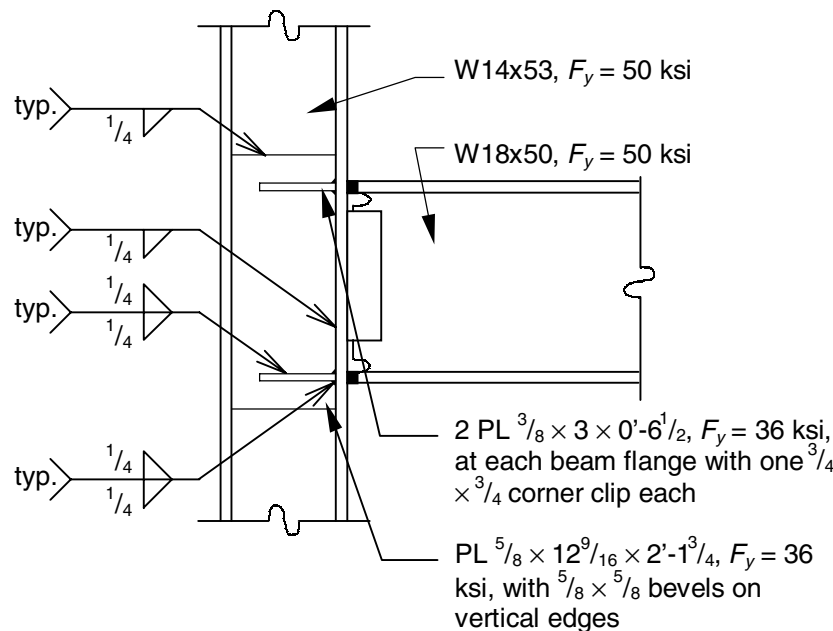

Figure 6-3 Framing arrangement for Example 6-3 (Solution A).

flange with $\frac{1}{4}$ -in. double-sided fillet welds and to the column web or web doubler plate with $\frac{3}{16}$ -in. double-sided fillet welds. This column-stiffening configuration is illustrated in Figure 6-4.

Example 6-4

Given:

Determine if transverse stiffeners and/or a web doubler plate will be required for the flange-plated moment connection illustrated in Figure 6-5. The moments transferred

at each connection are: ± 250 ft-kips due to lateral load, -100 ft-kips due to total gravity load and -45 ft-kips due to dead load only. The axial compression in the column is 500 kips. The connections are part of a frame in a wind or low-seismic application. Neglect the effects of story shear for calculation purposes.

$$W18 \times 50, F_y = 50 \text{ ksi}$$

$$d = 17.99 \text{ in.} \quad b_f = 7.495 \text{ in.}$$

$$t_w = 0.355 \text{ in.} \quad t_f = 0.570 \text{ in.}$$

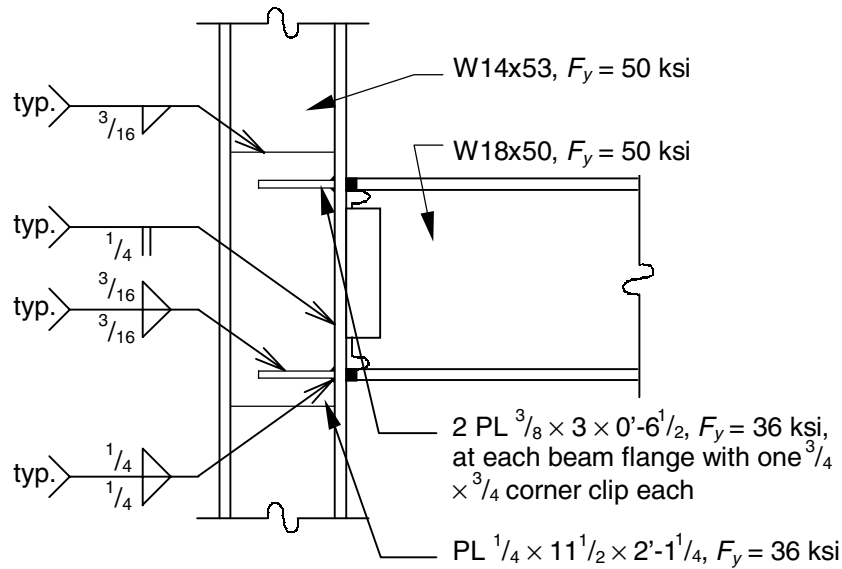

Figure 6-4 Framing arrangement for Example 6-3 (Solution B).

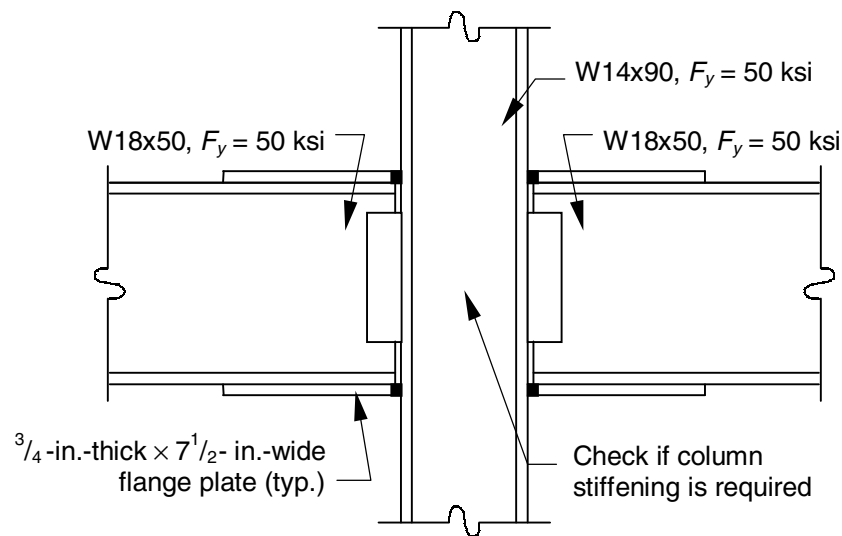

Figure 6-5 Framing arrangement for Example 6-4.

$$\begin{aligned} \text{W14} \times 90, F_y &= 50 \text{ ksi} \\ d &= 14.02 \text{ in.} \quad b_f = 14.520 \text{ in.} \quad k = 1\frac{3}{8} \text{ in.} \\ k_1 &= \frac{7}{8} \text{ in.} \quad t_w = 0.440 \text{ in.} \quad t_f = 0.710 \text{ in.} \\ T &= 11\frac{1}{4} \text{ in.} \quad A = 26.5 \text{ in.}^2 \end{aligned}$$

Use $\frac{3}{4}$ -in.-thick by $7\frac{1}{2}$ -in.-wide flange plates.

Solution:

Calculate the flange forces and panel-zone shear force:
The worst-case flange force for all limit states except compression buckling of the web and panel-zone web shear is that due to the combined effects of the 250 ft-kip moment due to lateral load and the 100 ft-kip moment due to total gravity load. From Equation 2.1-1, the corresponding flange force is

$$\begin{aligned} P_{uf} &= \frac{M_u}{d + t_{pl}} = \frac{(250 \text{ ft-kips} + 100 \text{ ft-kips})(12 \text{ in./ft})}{(17.99 \text{ in.} + \frac{3}{4} \text{ in.})} \\ &= 224 \text{ kips} \end{aligned}$$

The worst-case flange force for the web compression buckling limit state is that due to the combined effects of the opposing 100 ft-kip moments due to total gravity load. From Equation 2.1-1, the corresponding flange force is

$$\begin{aligned} P'_{uf} &= \frac{M_u}{d + t_{pl}} = \frac{(100 \text{ ft-kips})(12 \text{ in./ft})}{(17.99 \text{ in.} + \frac{3}{4} \text{ in.})} \\ &= 64.0 \text{ kips} \end{aligned}$$

Neglecting the effects of story shear, the worst-case panel-zone web shear force is that due to the combined effects of the two 250 ft-kip moment due to lateral load (in reverse curvature), the 100 ft-kip moment due to total gravity load on one side (adding) and the 45 ft-kip moment due to dead load only on the other side (subtracting). From Equation 2.1-1, the corresponding flange forces are

$$\begin{aligned} (P_{uf})_1 &= \frac{(M_u)_1}{d + t_{pl}} \\ &= \frac{(250 \text{ ft-kips} + 100 \text{ ft-kips})(12 \text{ in./ft})}{(17.99 \text{ in.} + \frac{3}{4} \text{ in.})} \\ &= 224 \text{ kips} \\ (P_{uf})_2 &= \frac{(M_u)_2}{d + t_{pl}} \\ &= \frac{250 \text{ ft-kips} - 45 \text{ ft-kips})(12 \text{ in./ft})}{(17.99 \text{ in.} + \frac{3}{4} \text{ in.})} \\ &= 131 \text{ kips} \end{aligned}$$

The corresponding panel-zone web shear force is determined from Equation 2.1-5 as

$$\begin{aligned} V_u &= (P_{uf})_1 + (P_{uf})_2 \\ &= 224 \text{ kips} + 131 \text{ kips} \\ &= 355 \text{ kips} \end{aligned}$$

Determine the design panel-zone web shear strength:
Assuming the behavior of the panel-zone remains nominally within the elastic range,

$$\begin{aligned} P_y &= F_y A = (50 \text{ ksi})(26.5 \text{ in.}^2) = 1,330 \text{ kips} \\ \frac{P_u}{P_y} &= \frac{500 \text{ kips}}{1,330 \text{ kips}} = 0.376 \end{aligned}$$

Since this ratio is less than 0.4, Equation 2.2-1 is applicable.

$$\begin{aligned} \phi R_v &= 0.9 \times 0.6 F_y d_c t_w \\ &= 0.9 \times 0.6 (50 \text{ ksi})(14.02 \text{ in.})(0.440 \text{ in.}) \\ &= 167 \text{ kips} < V_u = 355 \text{ kips} \quad \mathbf{n.g.} \end{aligned}$$

Therefore, the web of the W14×90 is inadequate to resist the panel-zone web shear without reinforcement.

Determine the design strength of the flange and web to resist the flange forces in tension:

For a tensile flange force, the limit states of local flange bending and local web yielding must be checked. For local flange bending, from Equation 2.2-8,

$$\begin{aligned} \phi R_n &= 0.9 \times 6.25 t_f^2 F_y \times C_t \\ &= 0.9 \times 6.25 (0.710 \text{ in.})^2 (50 \text{ ksi}) \times 1 \\ &= 142 \text{ kips} < P_{uf} = 224 \text{ kips} \quad \mathbf{n.g.} \end{aligned}$$

For local web yielding, from Equation 2.2-10,

$$\begin{aligned} \phi R_n &= 1.0 \times [C_t(5k) + N] F_y t_w \\ &= 1.0 \times [1(5)(1\frac{3}{8} \text{ in.}) + \frac{3}{4} \text{ in.}](50 \text{ ksi})(0.440 \text{ in.}) \\ &= 168 \text{ kips} < P_{uf} = 224 \text{ kips} \quad \mathbf{n.g.} \end{aligned}$$

Therefore, the flange and web of the W14×90 are inadequate to resist the tensile flange force without reinforcement.

Determine the design strength of the web to resist the flange forces in compression:

For a compressive flange force, the limit states of local web yielding, web crippling, and compression buckling of the web must be checked. For local web yielding, as determined previously,

$$\phi R_n = 168 \text{ kips} < P_{uf} = 224 \text{ kips} \quad \mathbf{n.g.}$$

For web crippling, from Equation 2.2-12,

$$N_d = \frac{3N}{d} = \frac{3(3/4 \text{ in.})}{14.02 \text{ in.}} = 0.160$$

$$\begin{aligned}\phi R_n &= 0.75 \times 135 C_t t_w^2 \left[1 + N_d \left(\frac{t_w}{t_f} \right)^{1.5} \right] \sqrt{\frac{F_y t_f}{t_w}} \\ &= 0.75 \times 135 (1) (0.440 \text{ in.})^2 \\ &\times \left[1 + (0.160) \left(\frac{0.440 \text{ in.}}{0.710 \text{ in.}} \right)^{1.5} \right] \sqrt{\frac{(50 \text{ ksi})(0.710 \text{ in.})}{0.440 \text{ in.}}} \\ &= 190 \text{ kips} < P_{uf} = 224 \text{ kips} \quad \mathbf{n.g.}\end{aligned}$$

For compression buckling of the web, from Equation 2.2-13,

$$\begin{aligned}\phi R_n &= 0.90 \times \frac{4,100 C_t t_w^3 \sqrt{F_y}}{h} \\ &= 0.90 \times \frac{4,100 (1) (0.440 \text{ in.})^3 \sqrt{50 \text{ ksi}}}{14.02 \text{ in.} - 2(1\frac{3}{8} \text{ in.})} \\ &= 197 \text{ kips} > P'_{uf} = 64.0 \text{ kips} \quad \mathbf{o.k.}\end{aligned}$$

Therefore, the web of the W14×90 is inadequate to resist the compressive flange force without reinforcement, except for the web compression buckling limit state.

Summary:

The W14×90 is inadequate to resist the local forces that are induced without column stiffening. For the selection of a column that is adequate without stiffening, refer to Example 6-5. For the design of stiffening for the W14×90, refer to Example 6-6.

Comments:

The foregoing solution can be determined more expediently using the design aids in Appendices A and B. The design panel-zone web shear strength is determined from Table A-1 where, for a W14×90 with $P_u/P_y \times 0.4$,

$$\phi R_v = 167 \text{ kips} < V_u = 355 \text{ kips} \quad \mathbf{n.g.}$$

The design strength of the flange and web to resist the flange force in tension is determined from Table B-1 where, for a W14×90, with $N = 3/4$ in. and reading from the **T** column,

$$\phi R_n = 142 \text{ kips} < P_{uf} = 224 \text{ kips} \quad \mathbf{n.g.}$$

The design strength of the web to resist the flange force in compression is also determined from Table B-1 where, for a W14×90, with $N = 3/4$ in. and reading from the **C** column,

$$\phi R_n = 168 \text{ kips} < P_{uf} = 224 \text{ kips} \quad \mathbf{n.g.}$$

The design strength of the web to resist compression buckling is also determined from Table B-1 where, for a W14×90,

$$\phi R_n = 197 \text{ kips} > P_{uf} = 64.0 \text{ kips} \quad \mathbf{o.k.}$$

Example 6-5

Given:

For the framing arrangement given in Example 6-4, reselect the column size to eliminate the need for stiffening.

Solution:

Try a W14×193 with $F_y = 50$ ksi:

$$P_y = F_y A = (50 \text{ ksi})(56.8 \text{ in.}^2) = 2,840 \text{ kips}$$

$$\frac{P_u}{P_y} = \frac{500 \text{ kips}}{2,840 \text{ kips}} = 0.176$$

From Table A-1, with $P_u/P_y \leq 0.4$,

$$\phi R_v = 372 \text{ kips} > V_u = 355 \text{ kips} \quad \mathbf{o.k.}$$

From Table B-1, with $N = 3/4$ in.,

$$\phi R_n = 506 \text{ kips(T)} > P_{uf} = 224 \text{ kips} \quad \mathbf{o.k.}$$

$$= 506 \text{ kips(C)} > P_{uf} = 224 \text{ kips} \quad \mathbf{o.k.}$$

$$= 1,640 \text{ kips (compression buckling)}$$

$$> P_{uf} = 64.0 \text{ kips} \quad \mathbf{o.k.}$$

Summary:

As illustrated in Figure 6-6, a W14×193 column ($F_y = 50$ ksi) can be used without stiffening. This column-weight increase of 103 lb/ft (= 193–90) is well within the range identified as economical in Chapter 3 for the elimination of two pairs of full-depth transverse stiffeners and a web doubler plate.

Example 6-6

Given:

For the framing arrangement given in Example 6-4 (a wind or low-seismic application), design the transverse stiffeners and web doubler plates that are required to increase the local column strength. Use a stiffening detail with a pair of full-depth transverse stiffeners at each flange plate and a pair of web doubler plates that extend to the transverse stiffeners (Figure 4-12a). Use ASTM A36 material for the stiffening elements, transverse stiffeners with fillet-welded joint details and groove-welded web doubler plate edge details.

Solution:

Calculate the transverse stiffener forces and web doubler plate shear force:

From Equation 4.2-1, the required strength for the transverse stiffeners is

$$\begin{aligned} R_{ust} &= P_{uf} - \phi R_{n \min} = 224 \text{ kips} - 142 \text{ kips} \\ &= 82 \text{ kips} \end{aligned}$$

From Equation 4.2-2, the required strength for the two web doubler plates is

$$\begin{aligned} V_{udp} &= V_u - \phi R_{v \text{ cw}} = 355 \text{ kips} - 167 \text{ kips} \\ &= 188 \text{ kips} \end{aligned}$$

Design the web doubler plates and their associated welding:

For strength, from Equation 4.4-1, the total thickness of web doubler plates required is

$$\begin{aligned} t_p &\geq \frac{V_{udp}}{0.9 \times 0.6 F_y d_c} \\ &\geq \frac{188 \text{ kips}}{0.9 \times 0.6 (36 \text{ ksi})(14.02 \text{ in.})} \\ &\geq 0.690 \text{ in. (or 0.345 in. per plate)} \end{aligned}$$

Check minimum thickness required to prevent shear buckling of the web doubler plate. From Equation 4.4-5,

$$\begin{aligned} t_{p \min} &= \frac{h \sqrt{F_y}}{418} = \frac{[14.02 \text{ in.} - 2(0.710 \text{ in.})] \sqrt{36 \text{ ksi}}}{418} \\ &= 0.181 \text{ in.} \end{aligned}$$

The thickness required for strength governs.

The web doubler plate width and depth are selected based upon the dimensions of the panel-zone and the edge details. Transverse to the axis of the column, the web doubler plate dimension is selected equal to the T-dimension of the column, plus twice the permissible encroachment from LRFD Manual Table 9-1 (page 9-12), which is $11\frac{1}{4} \text{ in.} + 2(\frac{1}{4} \text{ in.}) = 11\frac{3}{4} \text{ in.}$ Parallel to the axis of the column, the web doubler plate dimension is selected equal to the beam depth plus two times the flange-plate thickness minus two times the transverse stiffener thickness minus two times the root opening for the CJP groove weld that will be used to connect the web doubler plate along the top and bottom edges. Assuming $\frac{1}{2}$ -in. transverse stiffener thickness and a $\frac{3}{8}$ -in. root opening for the CJP groove weld, $17.99 \text{ in.} + 2(\frac{3}{4} \text{ in.}) - 2(\frac{1}{2} \text{ in.}) - 2(\frac{3}{8} \text{ in.}) = 17\frac{3}{4} \text{ in.}$, nominally.

Use 2 PL $\frac{3}{8} \text{ in.} \times 11\frac{3}{4} \text{ in.} \times 1'-5\frac{3}{4}$.

The column-flange edges are to be CJP groove welded.

Use $\frac{3}{8}$ -in. CJP groove welds to connect the web doubler plates to the column flanges.

The top and bottom edges of the web doubler plates are welded to the column web and transverse stiffeners with CJP groove welds. **Use $\frac{3}{8}$ -in. CJP groove welds to connect the top and bottom edges of the web doubler plate to the column web.**

Design the transverse stiffeners and their associated welding:

From Equation 4.3-1, the minimum required cross-sectional area for the transverse stiffeners at each flange is

$$A_{st \min} = \frac{R_{ust}}{\phi F_{yst}} = \frac{82 \text{ kips}}{0.9(36 \text{ ksi})} = 2.53 \text{ in.}^2$$

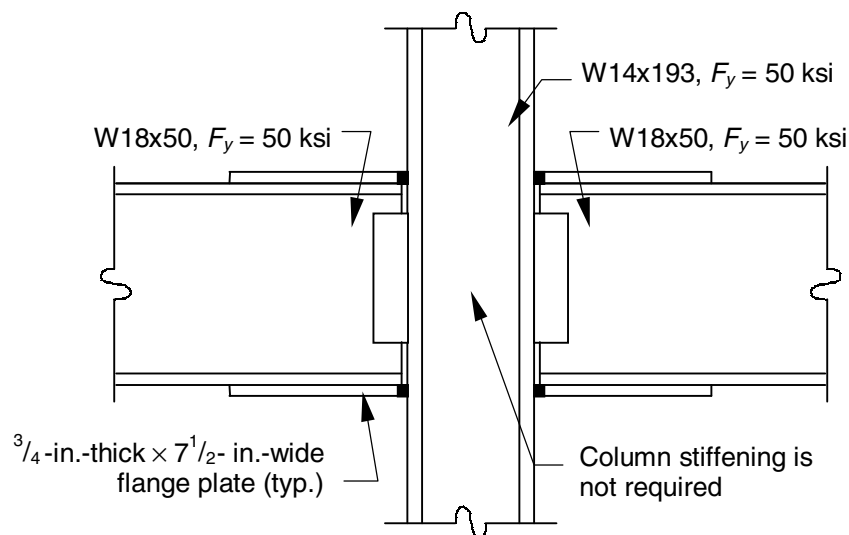

Figure 6-6 Framing arrangement for Example 6-5.

From Equation 4.3-2, the minimum width of each transverse stiffener is

$$b_{s \min} = \frac{b}{3} - \frac{t_{pz}}{2} = \frac{7\frac{1}{2} \text{ in.}}{3} - \frac{0.440 \text{ in.}}{2} = 2.28 \text{ in.}$$

Try a pair of 3 $\frac{1}{2}$ -in.-wide transverse stiffeners at each beam flange with $\frac{3}{4}$ -in. \times $\frac{3}{4}$ -in. corner clips. From Equation 4.3-3, the minimum thickness is

$$\begin{aligned} t_{s \min} &= \frac{t}{2} \geq \frac{b_s \sqrt{F_{yst}}}{95} \\ &= \frac{\frac{3}{4} \text{ in.}}{2} \geq \frac{(3\frac{1}{2} \text{ in.}) \sqrt{36 \text{ ksi}}}{95} \\ &= 0.375 \text{ in.} \geq 0.221 \text{ in.} \end{aligned}$$

Try a $\frac{1}{2}$ -in. transverse stiffener thickness.

$$\begin{aligned} A_{st} &= 2(\frac{1}{2} \text{ in.})(3\frac{1}{2} \text{ in.} - \frac{3}{4} \text{ in.}) \\ &= 2.75 \text{ in.}^2 > A_{st \min} = 2.53 \text{ in.}^2 \quad \mathbf{o.k.} \end{aligned}$$

The length of the transverse stiffeners is selected equal to the depth of the column minus two times the column flange thickness, which is 14.02 in. $-$ 2(0.710 in.) = 12 $\frac{5}{8}$ in.

Check the shear strength of the transverse stiffener to transmit the unbalanced force in the transverse stiffener to the column panel-zone. Neglecting the effects of story shear, the worst-case unbalanced force in the transverse stiffener is that due to the combined effects of the two 250 ft-kip moment due to lateral load (in reverse curvature), the 100 ft-kip moment due to total gravity load on one side (adding) and the 45 ft-kip moment due to dead load only on the other side (subtracting). The unbalanced force in the transverse stiffener is

$$\begin{aligned} (R_{ust})_1 + (R_{ust})_2 &= (P_{uf} - \phi R_{n \min})_1 + (P_{uf} - \phi R_{n \min})_2 \\ &= (224 \text{ kips} - 142 \text{ kips}) \\ &\quad + (131 \text{ kips} - 168 \text{ kips}) \\ &= 82 \text{ kips} + 0 \text{ kips} \\ &= 82 \text{ kips} \end{aligned}$$

From Equation 4.3-5,

$$\begin{aligned} t_s &\geq \frac{(R_{ust})_1 + (R_{ust})_2}{0.9 \times 0.6 F_{yst} (l - 2 \times clip) \times 2} \\ &\geq \frac{82 \text{ kips}}{0.9 \times 0.6 (36 \text{ ksi}) (12.6 \text{ in.} - 2 \times \frac{3}{4} \text{ in.}) \times 2} \\ &\geq 0.190 \text{ in.} \end{aligned}$$

Therefore, a $\frac{1}{2}$ -in. transverse stiffener thickness is **o.k.**

Use 2 PL $\frac{1}{2}$ -in. \times 3 $\frac{1}{2}$ in. \times 1'-0 $\frac{9}{16}$ with two $\frac{3}{4}$ -in. \times $\frac{3}{4}$ -in. corner clips each at each flange plate.

The double-sided fillet welds connecting the transverse stiffeners to the column flanges are sized to develop the

strength of the welded portion of the transverse stiffener. From Equation 4.3-6, the weld size required for strength is

$$\begin{aligned} w_{\min} &= \frac{0.943 F_{yst} t_s}{F_{EXX}} = \frac{0.943 (36 \text{ ksi}) (\frac{1}{2} \text{ in.})}{70 \text{ ksi}} \\ &= 0.242 \text{ in.} \sim \frac{1}{4} \text{ in.} \end{aligned}$$

From LRFD Specification Table J2.4, with $\frac{1}{2}$ -in.-thick transverse stiffeners and 0.710-in.-thick column flanges, the minimum weld size is $\frac{1}{4}$ in. **Use $\frac{1}{4}$ -in. double-sided fillet welds to connect the transverse stiffeners to the column flange.**

The transverse stiffeners are to be connected to the column panel zone with a detail that combines two fillet welds and two CJP groove weld as illustrated in Figure 4-12a. From Equation 4.3-10, the fillet weld size required for strength is

$$\begin{aligned} w &\geq \frac{(R_{ust})_1 + (R_{ust})_2}{0.75 \times 0.6 F_{EXX} (l - 2 \times clip) \times 2 \times \sqrt{2}} \\ &\geq \frac{82 \text{ kips}}{0.75 \times 0.6 (70 \text{ ksi}) (12.6 \text{ in.} - 2 \times \frac{3}{4} \text{ in.}) \times 2 \times \sqrt{2}} \\ &\geq 0.0829 \text{ in.} \end{aligned}$$

From LRFD Specification Table J2.4, the minimum weld size for the $\frac{1}{2}$ -in.-thick transverse stiffener, $\frac{3}{8}$ -in.-thick web doubler plate and 0.440-in.-thick column web is $\frac{3}{16}$ in. **Use $\frac{3}{16}$ -in. fillet welds.**

Each $\frac{3}{8}$ -in. CJP groove weld must transmit one-quarter of the 82-kip unbalanced force in the transverse stiffeners (20.5 kips). From LRFD Specification Table J2.5, the shear strength is the lesser of that on the effective area in the transverse stiffener base metal and that in the weld itself. For the transverse stiffener base metal,

$$\begin{aligned} \phi R_n &= 0.9 \times 0.6 F_{yst} w' (l - 2 \times clip) \\ &= 0.9 \times 0.6 (36 \text{ ksi}) (\frac{3}{8} \text{ in.}) (12.6 \text{ in.} - 2 \times \frac{3}{4} \text{ in.}) \\ &= 80.9 \text{ kips} > 20.5 \text{ kips} \quad \mathbf{o.k.} \end{aligned}$$

For the weld metal,

$$\begin{aligned} \phi R_n &= 0.8 \times 0.6 F_{EXX} w' (l - 2 \times clip) \\ &= 0.8 \times 0.6 (70 \text{ ksi}) (\frac{3}{8} \text{ in.}) (12.6 \text{ in.} - 2 \times \frac{3}{4} \text{ in.}) \\ &= 140 \text{ kips} > 20.5 \text{ kips} \quad \mathbf{o.k.} \end{aligned}$$

The column web and web doubler plate thicknesses must also be checked for shear strength to transmit the unbalanced force in the transverse stiffeners to the panel-zone. For this detail, one-half of the unbalanced force (41 kips, the shear transmitted by the fillet welds) can be assigned to the column web with one-quarter (20.5 kips, the shear transmitted by each CJP groove weld) assigned to

each web doubler plate. For the column web, the design shear strength is

$$\begin{aligned}\phi R_n &= 0.9 \times 0.6 F_y d_{ctw} \\ &= 0.9 \times 0.6 (50 \text{ ksi}) (14.02 \text{ in.}) (0.440 \text{ in.}) \\ &= 167 \text{ kips} > 41 \text{ kips} \quad \mathbf{o.k.}\end{aligned}$$

For the web doubler plate, the design shear strength is

$$\begin{aligned}\phi R_n &= 0.9 \times 0.6 F_{yp} d_{cpt} \\ &= 0.9 \times 0.6 (36 \text{ ksi}) (14.02 \text{ in.}) (3/8 \text{ in.}) \\ &= 102 \text{ kips} > 20.5 \text{ kips} \quad \mathbf{o.k.}\end{aligned}$$

Therefore, the column web and web doubler plates are of adequate thickness to provide for proper force transfer of the unbalance force in the transverse stiffener to the panel-zone. If either the column web or the web doubler plate thickness were inadequate in the above calculations, shear transfer between these elements on the effective area of the CJP groove weld root area can be utilized as a load path. Note, however, that if force is to be transferred from the column web to the web doubler plate in this manner, the maximum force transfer may be limited by the design shear strength on the effective area at the juncture between the CJP groove weld and the web doubler plate.

Summary:

The use of a W14×90 column requires the use of a pair of web doubler plates and a pair of transverse stiffeners

at the location of each beam flange plate. The web doubler plates required are 2 PL $3/8$ in. \times $11^{3/4}$ in. \times $1'-5^{3/4}$. They are welded to the column flanges along the column-flange edges and to the column web and transverse stiffeners along the top and bottom edges with $3/8$ -in. CJP groove welds. The transverse stiffeners required are 4 PL $1/2$ -in. \times $3^{1/2}$ in. \times $1'-0^{9/16}$ with two $3/4$ -in. \times $3/4$ -in. corner clip each. Each transverse stiffener is welded to the column flange with $1/4$ -in. double-sided fillet welds and to the column web and web doubler plates with a combination of a $3/16$ -in. single-sided fillet weld and $3/8$ -in. CJP groove weld. This column-stiffening configuration is illustrated in Figure 6-7.

Example 6-7

Given:

Repeat Example 6-1 using a four-bolt extended end-plate moment connection as illustrated in Figure 6-8 instead of a directly welded flange moment connection. For the end-plate thickness, use $3/4$ in. For the beam-flange-to-end-plate welds, use $1/2$ -in. fillet welds on both sides of the beam flange.

Use the following end-plate parameters in the calculations (see Section 2.2.2):

$$p_f = 1^{1/2} \text{ in.}$$

$$g = 5^{1/2} \text{ in.}$$

$$d_b = 1 \text{ in.}$$

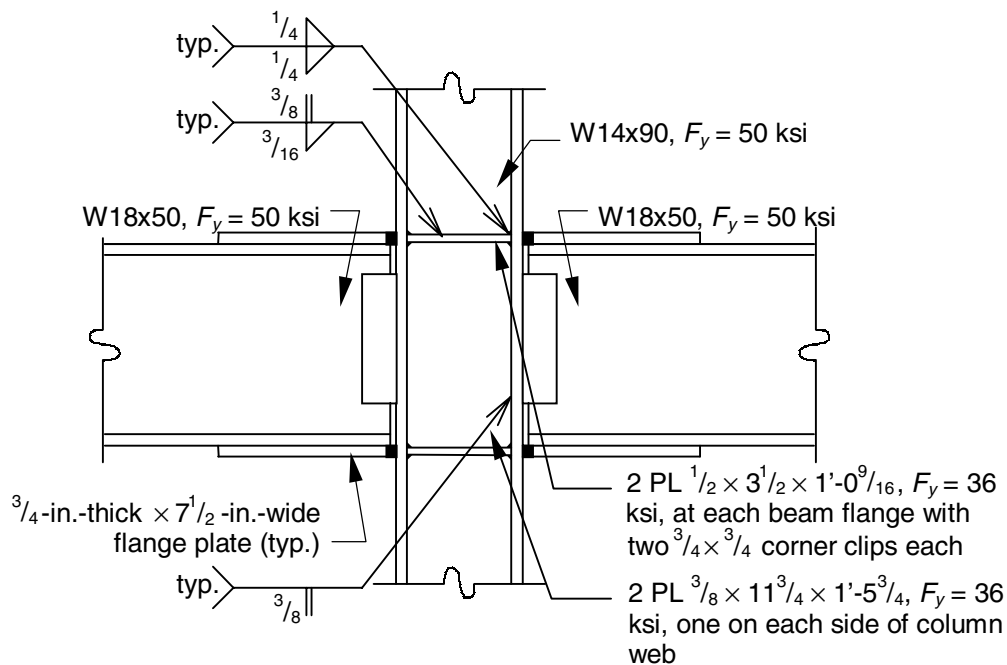

Figure 6-7 Framing arrangement for Example 6-6.

Solution:

Calculate the flange forces and panel-zone shear force:
From Example 6-1,

$$P_{uf} = 172 \text{ kips}$$

$$V_u = 172 \text{ kips}$$

Determine the design panel-zone web shear strength:
From Example 6-1,

$$\phi R_v = 139 \text{ kips} < V_u = 172 \text{ kips} \quad \mathbf{n.g.}$$

Therefore, the web of the W14×53 is inadequate to resist the panel-zone web shear without reinforcement.

Determine the design strength of the flange and web to resist the flange forces in tension:

For a tensile flange force, the limit states of local flange bending and local web yielding must be checked. For local flange bending, from Equation 2.2-9,

$$\begin{aligned} b_s &= 2.5(2p_f + t_{fb}) \\ &= 2.5(2 \times 1\frac{1}{2} \text{ in.} + 0.570 \text{ in.}) \\ &= 8.93 \text{ in.} \end{aligned}$$

$$\begin{aligned} p_e &= \frac{g}{2} - \frac{d_b}{4} - k_1 \\ &= \frac{5\frac{1}{2} \text{ in.}}{2} - \frac{1 \text{ in.}}{4} - 1\frac{5}{16} \text{ in.} = 1.56 \text{ in.} \end{aligned}$$

$$\alpha_m = 1.36 \left(\frac{p_e}{d_b} \right)^{1/4} = 1.36 \left(\frac{1.56 \text{ in.}}{1 \text{ in.}} \right)^{1/4} = 1.52$$

$$\begin{aligned} \phi R_n &= 0.9 \times \left(\frac{b_s}{\alpha_m p_e} \right)^2 t_f^2 F_y \times C_t \\ &= 0.9 \times \left(\frac{8.93 \text{ in.}}{(1.52)(1.56 \text{ in.})} \right)^2 (0.660 \text{ in.})^2 (36 \text{ ksi}) \times 1 \\ &= 53.2 \text{ kips} < P_{uf} = 172 \text{ kips} \quad \mathbf{n.g.} \end{aligned}$$

Note that F_y has been conservatively taken as 36 ksi as recommended in Section 2.2.2. For local web yielding, from Equation 2.2-11,

$$\begin{aligned} \phi R_n &= 1.0 \times [C_t(6k + 2t_p) + N]F_y t_w \\ &= 1.0 \times [(1)(6 \times 1\frac{7}{16} \text{ in.} + 2 \times \frac{3}{4} \text{ in.}) \\ &\quad + 0.570 \text{ in.}](50 \text{ ksi})(0.370 \text{ in.}) \\ &= 198 \text{ kips} > P_{uf} = 172 \text{ kips} \quad \mathbf{o.k.} \end{aligned}$$

Therefore, while the web thickness is adequate, the flange of the W14×53 is inadequate to resist the tensile flange force without reinforcement.

Determine the design strength of the web to resist the flange forces in compression:

For a compressive flange force, the limit states of local web yielding, web crippling, and compression buckling of the web must be checked. In this case, the compression buckling limit state does not apply because there is a moment connection to one flange only. For local web yielding, as determined previously,

$$\phi R_n = 198 \text{ kips} > P_{uf} = 172 \text{ kips} \quad \mathbf{o.k.}$$

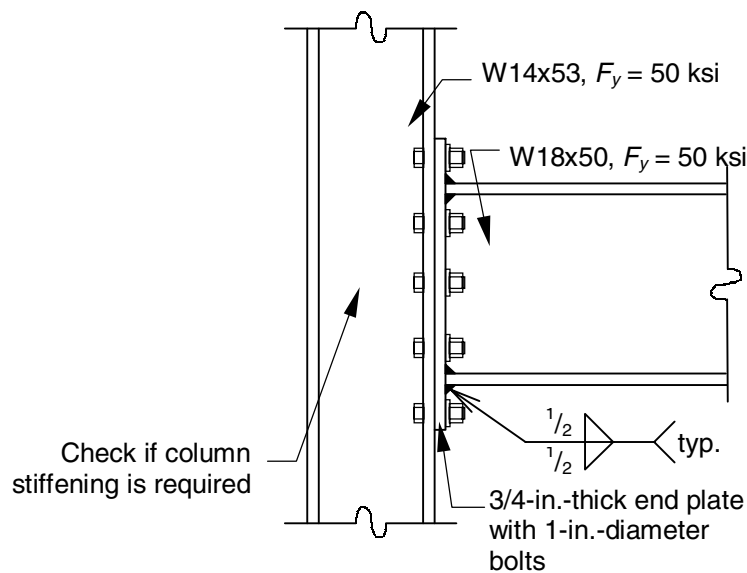

Figure 6-8 Framing arrangement for Example 6-7.

For web crippling, from Equation 2.2-12,

$$N = 2w + 2t_p = 2(1/2 \text{ in.}) + 2(3/4 \text{ in.}) = 2.50 \text{ in.}$$

$$N_d = \frac{3N}{d_c} = \frac{3(2.50 \text{ in.})}{13.92 \text{ in.}} = 0.539$$

$$\begin{aligned} \phi R_n &= 0.75 \times 135 C_t t_w^2 \left[1 + N_d \left(\frac{t_w}{t_f} \right)^{1.5} \right] \\ &\quad \times \sqrt{\frac{F_y t_f}{t_w}} \\ &= 0.75 \times 135 (1) (0.370 \text{ in.})^2 \\ &\quad \times \left[1 + (0.539) \left(\frac{0.370 \text{ in.}}{0.660 \text{ in.}} \right)^{1.5} \right] \sqrt{\frac{(50 \text{ ksi})(0.660 \text{ in.})}{0.370 \text{ in.}}} \\ &= 161 \text{ kips} < P_{uf} = 172 \text{ kips} \quad \mathbf{n.g.} \end{aligned}$$

Therefore, the web of the W14×53 is inadequate to resist the compressive flange force without reinforcement.

Summary:

The W14×53 is inadequate to resist the local forces that are induced without column stiffening. For the selection of a column that is adequate without stiffening, refer to Example 6-8. Although the design of stiffening for the W14×53 is not illustrated with an example problem for this case, it can be accomplished in a manner that is similar to that illustrated in Example 6-3.

Example 6-8

Given:

For the framing arrangement given in Example 6-7, reselect a column size that will eliminate the need for stiffening.

Solution:

As determined in Example 6-7, the flange thickness must be increased to increase the local flange bending strength and the web thickness must be increased to increase the web crippling strength and the panel-zone web shear strength. The required flange thickness is determined using a rearranged form of Equation 2.2-9 as

$$\begin{aligned} t_{f \text{ req}} &= \sqrt{\frac{P_{uf} p_e \alpha_m}{\phi F_y b_s C_t}} = \sqrt{\frac{(172 \text{ kips})(1.56 \text{ in.})(1.52)}{0.9(36 \text{ ksi})(8.93 \text{ in.})(1.0)}}} \\ &= 1.19 \text{ in.} \end{aligned}$$

Note that F_y has been conservatively taken as 36 ksi as recommended in Section 2.2.2. A W14×159 has a flange thickness equal to 1.19 in.

Check the web thickness of the W14×159 for web crippling. From Equation 2.2-12,

$$N_d = \frac{3N}{d} = \frac{3(0.570 \text{ in.} + 2 \times 1/2 \text{ in.} + 2 \times 3/4 \text{ in.})}{14.98 \text{ in.}}$$

$$= 0.615$$

$$\begin{aligned} \phi R_n &= 0.75 \times 135 C_t t_w^2 \left[1 + N_d \left(\frac{t_w}{t_f} \right)^{1.5} \right] \sqrt{\frac{F_y t_f}{t_w}} \\ &= 0.75 \times 135 (1) (0.745 \text{ in.})^2 \\ &\quad \times \left[1 + (0.615) \left(\frac{0.745 \text{ in.}}{1.19 \text{ in.}} \right)^{1.5} \right] \sqrt{\frac{(50 \text{ ksi})(1.19 \text{ in.})}{0.745 \text{ in.}}} \\ &= 655 \text{ kips} > P_{uf} = 172 \text{ kips} \quad \mathbf{o.k.} \end{aligned}$$

Check the web thickness of the W14×159 for panel-zone web shear. Assuming the behavior of the panel-zone remains nominally within the elastic range,

$$P_y = F_y A = (50 \text{ ksi})(46.7 \text{ in.}^2) = 2,340 \text{ kips}$$

$$\frac{P_u}{P_y} = \frac{300 \text{ kips}}{2,340 \text{ kips}} = 0.128$$

Since this ratio is less than 0.4, Equation 2.2-1 is applicable.

$$\begin{aligned} \phi R_v &= 0.9 \times 0.6 F_y d_c t_w \\ &= 0.9 \times 0.6 (50 \text{ ksi})(14.98 \text{ in.})(0.745 \text{ in.}) \\ &= 301 \text{ kips} > V_u = 172 \text{ kips} \quad \mathbf{o.k.} \end{aligned}$$

Summary:

As illustrated in Figure 6-9, a W14×159 column ($F_y = 50 \text{ ksi}$) can be used without stiffening. This column-weight increase of 106 lb/ft ($= 159 - 53$) is within the range identified as economical in Chapter 3 for the elimination of two pairs of partial-depth transverse stiffeners and a web doubler plate.

Example 6-9

Given:

Repeat Example 6-1, except with a column that ends 2 in. above the top of the beam as illustrated in Figure 6-10.

Solution:

Calculate the flange forces and panel-zone shear force: From Example 6-1,

$$P_{uf} = 172 \text{ kips}$$

$$V_u = 172 \text{ kips}$$

Determine which column-end criteria apply and if they apply at the near flange only or at both flanges of the beam:

The column-end criteria apply for local flange bending within $10t_f = 6.60$ in.; for local web yielding, within $d_c = 13.92$ in.; and for web crippling and compression buckling of the web within $d_c/2 = 6.96$ in. Thus, for a W18×50 beam, with $d = 17.99$ in., the column-end criteria apply for all limit states at the near (top) flange only.

Determine the design panel-zone web shear strength:
From Example 6-1,

$$\phi R_v = 139 \text{ kips} < V_u = 172 \text{ kips} \quad \mathbf{n.g.}$$

Therefore, the web of the W14×53 is inadequate to resist the panel-zone web shear without reinforcement.

Determine the design strength of the flange and web to resist the flange forces in tension:

For a tensile flange force, the limit states of local flange bending and local web yielding must be checked. At the bottom flange force, from Example 6-1, for local flange bending,

$$\phi R_n = 123 \text{ kips} < P_{uf} = 172 \text{ kips} \quad \mathbf{n.g.}$$

and for local web yielding,

$$\phi R_n = 144 \text{ kips} < P_{uf} = 172 \text{ kips} \quad \mathbf{n.g.}$$

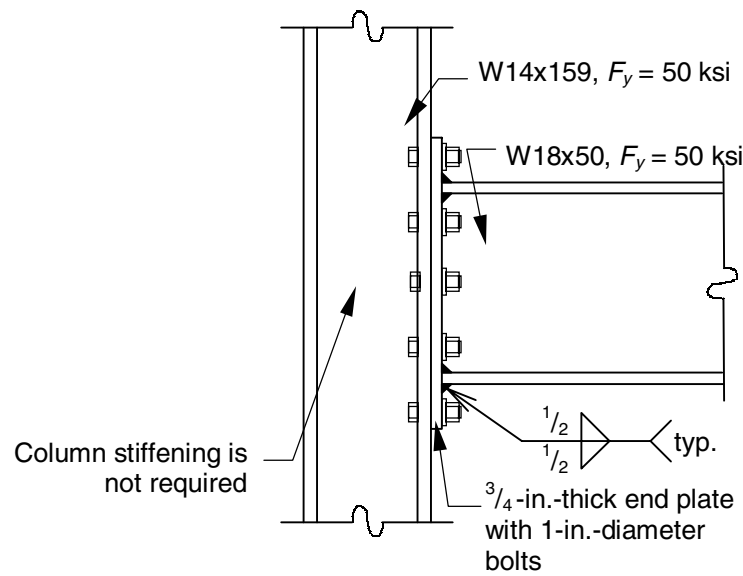

Figure 6-9 Framing arrangement for Example 6-8.

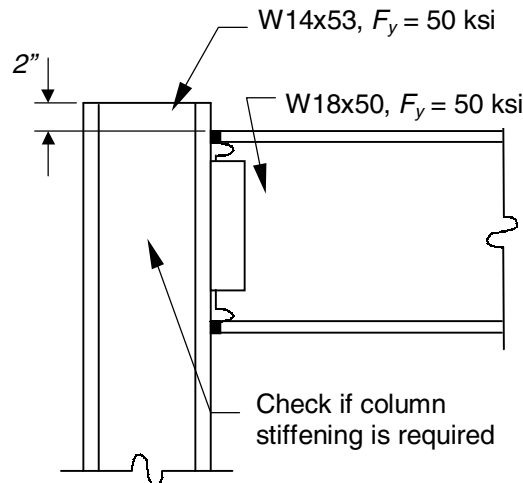

Figure 6-10 Framing arrangement for Example 6-9.

At the top flange force, for local flange bending, from Equation 2.2-8,

$$\begin{aligned}\phi R_n &= 0.9 \times 6.25 t_f^2 F_y \times C_t \\ &= 0.9 \times 6.25 (0.660 \text{ in.})^2 (50 \text{ ksi}) \times 0.5 \\ &= 61.3 \text{ kips} < P_{uf} = 172 \text{ kips} \quad \mathbf{n.g.}\end{aligned}$$

and for local web yielding, from Equation 2.2-10,

$$\begin{aligned}\phi R_n &= 1.0 \times [C_t(5k) + N] F_y t_w \\ &= 1.0 \times [0.5(5)(1\frac{7}{16} \text{ in.}) \\ &\quad + 0.570 \text{ in.}] (50 \text{ ksi}) (0.370 \text{ in.}) \\ &= 77.0 \text{ kips} < P_{uf} = 172 \text{ kips} \quad \mathbf{n.g.}\end{aligned}$$

Therefore, the flange and web of the W14×53 are inadequate to resist the tensile flange force without reinforcement at both the top and bottom flanges.

Determine the design strength of the web to resist the flange forces in compression:

For a compressive flange force, the limit states of local web yielding, web crippling, and compression buckling of the web must be checked. In this case, the compression buckling limit state does not apply because there is a moment connection to one flange only. At the bottom flange force, as determined previously, for local web yielding,

$$\phi R_n = 144 \text{ kips} < P_{uf} = 172 \text{ kips} \quad \mathbf{n.g.}$$

and for web crippling,

$$\phi R_n = 138 \text{ kips} < P_{uf} = 172 \text{ kips} \quad \mathbf{n.g.}$$

At the top flange force, for local web yielding, as determined previously,

$$\phi R_n = 77.0 \text{ kips} < P_{uf} = 172 \text{ kips} \quad \mathbf{n.g.}$$

and for web crippling, from Equation 2.2-12,

$$N_d = \frac{3N}{d_c} = \frac{3(0.570 \text{ in.})}{13.92 \text{ in.}} = 0.123$$

$$\begin{aligned}\phi R_n &= 0.75 \times 135 C_t t_w^2 \left[1 + N_d \left(\frac{t_w}{t_f} \right)^{1.5} \right] \sqrt{\frac{F_y t_f}{t_w}} \\ &= 0.75 \times 135 (0.5) (0.370 \text{ in.})^2 \\ &\quad \times \left[1 + (0.123) \left(\frac{0.370 \text{ in.}}{0.660 \text{ in.}} \right)^{1.5} \right] \sqrt{\frac{(50 \text{ ksi})(0.660 \text{ in.})}{0.370 \text{ in.}}} \\ &= 68.8 \text{ kips} < P_{uf} = 172 \text{ kips} \quad \mathbf{n.g.}\end{aligned}$$

Therefore, the web of the W14×53 is inadequate to resist the compressive flange force without reinforcement at both the top and bottom flanges.

Summary:

The W14×53 is inadequate to resist the local forces that are induced without column stiffening. For the selection of a column that is adequate without stiffening, refer to Example 6-10.

Comments:

The foregoing solution can be determined more expeditiously using the design aids in Appendices A, B, and C. The design panel-zone web shear strength is determined from Table A-1 where, for a W14×53 with $P_u/P_y \leq 0.4$,

$$\phi R_v = 139 \text{ kips} < V_u = 172 \text{ kips} \quad \mathbf{n.g.}$$

The design strength of the flange and web to resist the flange force in tension is determined from Tables B-1 and C-1 where, for a W14×53, with $N = 0.570 \text{ in.}$ and reading from the **T** column,

$$\begin{aligned}\phi R_n &= 123 \text{ kips at the bottom flange (Table B-1)} \\ &< P_{uf} = 172 \text{ kips} \quad \mathbf{n.g.}\end{aligned}$$

$$\begin{aligned}\phi R_n &= 61.3 \text{ kips at the top flange (Table C-1)} \\ &< P_{uf} = 172 \text{ kips} \quad \mathbf{n.g.}\end{aligned}$$

by interpolation between the values that are tabulated for $N = \frac{1}{2} \text{ in.}$ and $N = \frac{3}{4} \text{ in.}$ The design strength of the web to resist the flange force in compression is also determined from Tables B-1 and C-1 where, for a W14×53, with $N = 0.570 \text{ in.}$ and reading from the **C** column,

$$\begin{aligned}\phi R_n &= 138 \text{ kips at the bottom flange (Table B-1)} \\ &< P_{uf} = 172 \text{ kips} \quad \mathbf{n.g.}\end{aligned}$$

$$\begin{aligned}\phi R_n &= 69.3 \text{ kips at the top flange}^{21} \text{ (Table C-1)} \\ &< P_{uf} = 172 \text{ kips} \quad \mathbf{n.g.}\end{aligned}$$

by interpolation between the values that are tabulated for $N = \frac{1}{2} \text{ in.}$ and $N = \frac{3}{4} \text{ in.}$

Example 6-10

Given:

For the framing arrangement given in Example 6-9, reselect the column size to eliminate the need for stiffening:

- A) entirely.
- B) except the transverse stiffeners at the top flange force (near the column end).

²¹The slight discrepancy between the calculated value (68.8 kips) and the value determined by linear interpolation (69.3 kips) results because the equations used to generate the tabulated values are not linear.

Solution A:

Try a W14×159 with $F_y = 50$ ksi:

$$P_y = F_y A = (50 \text{ ksi})(46.7 \text{ in.}^2) = 2,340 \text{ kips}$$

$$= \frac{300 \text{ kips}}{2,340 \text{ kips}} = 0.128$$

From Table A-1, with $P_u/P_y \leq 0.4$,

$$\phi R_v = 301 \text{ kips} = V_u = 172 \text{ kips} \quad \mathbf{o.k.}$$

At the bottom flange force (away from the column end), from Table B-1, with $N = 0.570$ in.,

$$\phi R_n = 371 \text{ kips(T)} > P_{uf} = 172 \text{ kips} \quad \mathbf{o.k.}$$

$$= 371 \text{ kips(C)} > P_{uf} = 172 \text{ kips} \quad \mathbf{o.k.}$$

by interpolation between the values that are tabulated for $N = 1/2$ in. and $N = 3/4$ in. At the top flange force (near the column end), from Table C-1, with $N = 0.570$ in.,

$$\phi R_n = 194 \text{ kips(T)} > P_{uf} = 172 \text{ kips} \quad \mathbf{o.k.}$$

$$= 195 \text{ kips(C)} > P_{uf} = 172 \text{ kips} \quad \mathbf{o.k.}$$

by interpolation between the values that are tabulated for $N = 1/2$ in. and $N = 3/4$ in.

Solution B:

From Example 6-2, a W14×74 can be used without a web doubler plate and without transverse stiffeners at the bottom flange force. At the top flange force (near the column end), either a pair of partial-depth transverse stiffeners can be provided or a detail such as that illustrated in Figure 6-12 can be used.

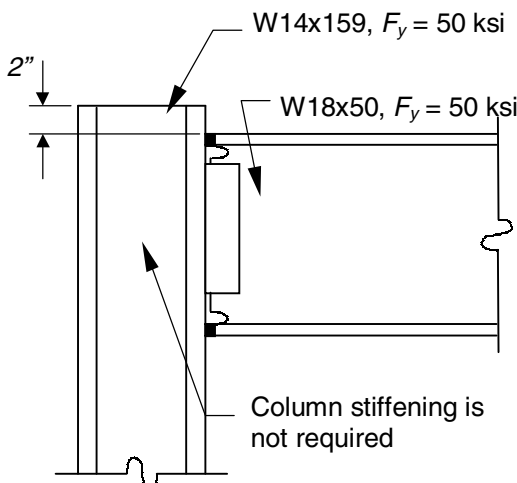

Figure 6-11 Framing arrangement for Example 6-10 (Solution A).

Summary A:

As illustrated in Figure 6-11 W14×159 column ($F_y = 50$ ksi) can be used without stiffening. This column-weight increase of 106 lb/ft ($= 159 - 53$) is within the range identified as economical in Chapter 3 for the elimination of two pairs of partial-depth transverse stiffeners and a web doubler plate.

Summary B:

A W14×74 column ($F_y = 50$ ksi) can be used without stiffening, except the transverse stiffeners at the top flange force (near the column end). This column-weight increase of 21 lb/ft ($= 74 - 53$) is well within the range identified as economical in Chapter 3 for the elimination of one pair of partial-depth transverse stiffeners and a web doubler plate.

Example 6-11

Given:

For a pair of $1/2$ -in.-thick full-depth transverse stiffeners ($F_y = 36$ ksi) that transmit an unbalanced force of 82 kips to a 0.440-in.-thick column web ($F_y = 50$ ksi) with a single $3/8$ -in.-thick web doubler plate ($F_y = 36$ ksi), proportion the welds and check shear in the column web and web doubler plate. The transverse stiffeners are 1'-0⁹/₁₆-in. long and have two $3/4$ -in. × $3/4$ -in. corner clips each. They are used with a W14×90 column. Use a joint detail as illustrated in:

- Figure 4-11a.
- Figure 4-11b.
- Figure 4-11c.
- Figure 4-11d.

Solution A:

The transverse stiffeners are to be connected to the column panel zone with a detail that combines three fillet welds and one CJP groove weld as illustrated in Figure 4-11a. From Equation 4.3-10, the fillet weld size required for strength is

$$w \geq \frac{(R_{ust})_1 + (R_{ust})_2}{0.75 \times 0.6 F_{EXX} (l - 2 \times clip) \times 2 \times \sqrt{2}}$$

$$\geq \frac{82 \text{ kips}}{0.75 \times 0.6 (70 \text{ ksi}) (12.6 \text{ in.} - 2 \times 3/4 \text{ in.}) \times 2 \times \sqrt{2}}$$

$$\geq 0.0829 \text{ in.}$$

From LRFD Specification Table J2.4, the minimum weld size for the $1/2$ -in.-thick transverse stiffener, $3/8$ -in.-thick web doubler plate, and 0.440-in.-thick column web is $3/16$ in. Use $3/16$ -in. fillet welds.

The $\frac{3}{8}$ -in. CJP groove weld must transmit one-quarter of the 82-kip unbalanced force in the transverse stiffeners (20.5 kips). From LRFD Specification Table J2.5, the shear strength is the lesser of that on the effective area in the transverse stiffener base metal and that in the weld itself. For the transverse stiffener base metal,

$$\begin{aligned}\phi R_n &= 0.9 \times 0.6 F_{yst} w' (l - 2 \times clip) \\ &= 0.9 \times 0.6 (36 \text{ ksi}) (\frac{3}{8} \text{ in.}) (12.6 \text{ in.} - 2 \times \frac{3}{4} \text{ in.}) \\ &= 80.9 \text{ kips} > 20.5 \text{ kips} \quad \mathbf{o.k.}\end{aligned}$$

For the weld metal,

$$\begin{aligned}\phi R_n &= 0.8 \times 0.6 F_{EXX} w' (l - 2 \times clip) \\ &= 0.8 \times 0.6 (70 \text{ ksi}) (\frac{3}{8} \text{ in.}) (12.6 \text{ in.} - 2 \times \frac{3}{4} \text{ in.}) \\ &= 140 \text{ kips} > 20.5 \text{ kips} \quad \mathbf{o.k.}\end{aligned}$$

The column web and web doubler plate thicknesses must also be checked for shear strength to transmit the unbalanced force in the transverse stiffeners to the panel-zone. For this detail, three-quarters of the unbalanced force (61.5 kips, the shear transmitted by the fillet welds) can be assigned to the column web with the remaining one-quarter (20.5 kips, the shear transmitted by the CJP groove

weld) assigned to the web doubler plate. For the column web, the design shear strength is

$$\begin{aligned}\phi R_n &= 0.9 \times 0.6 F_y d_c t_w \\ &= 0.9 \times 0.6 (50 \text{ ksi}) (14.02 \text{ in.}) (0.440 \text{ in.}) \\ &= 167 \text{ kips} > 61.5 \text{ kips} \quad \mathbf{o.k.}\end{aligned}$$

For the web doubler plate, the design shear strength is

$$\begin{aligned}\phi R_n &= 0.9 \times 0.6 F_{ydp} d_c t_{pl} \\ &= 0.9 \times 0.6 (36 \text{ ksi}) (14.02 \text{ in.}) (\frac{3}{8} \text{ in.}) \\ &= 102 \text{ kips} > 20.5 \text{ kips} \quad \mathbf{o.k.}\end{aligned}$$

Therefore, the column web and web doubler plate are of adequate thickness to provide for proper force transfer of the unbalance force in the transverse stiffeners to the panel-zone. If either the column web or the web doubler plate thickness were inadequate in the above calculations, shear transfer between these elements on the effective area of the CJP groove weld root area can be utilized as a load path. Note, however, that if force is to be transferred from the column web to the web doubler plate in this manner, the maximum force transfer may be limited by the design shear strength on the effective area at the juncture between the CJP groove weld and the web doubler plate.

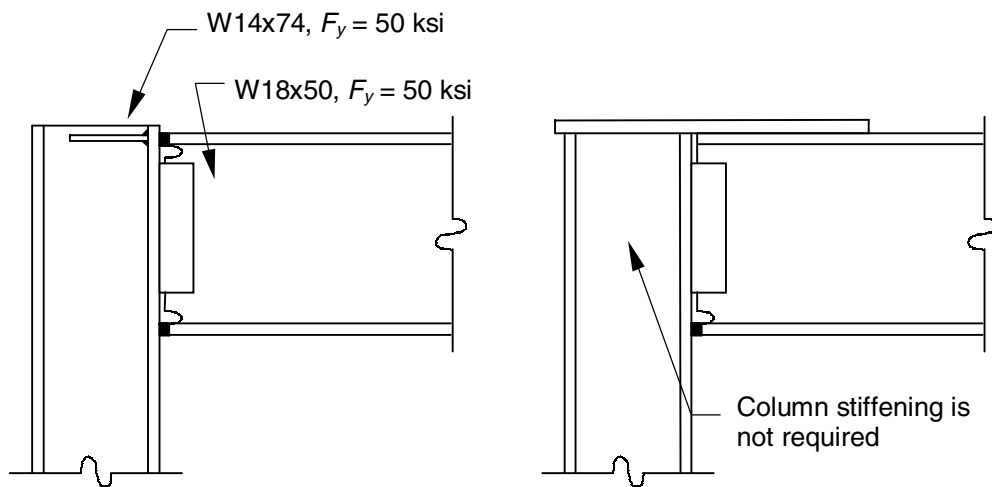

Note: column top extends past transverse stiffener to provide adequate shelf for fillet welds.

Figure 6-12 Framing arrangement for Example 6-10 (Solution B).

Solution B:

The solution for this example and the joint detail illustrated in Figure 4-11b is identical to Solution A.

Solution C:

The transverse stiffeners are to be connected to the column panel zone with a detail that combines three fillet welds and one CJP groove weld as illustrated in Figure 4-11c. For the fillet welds on the side of the web without a web doubler plate, from Equation 4.3-10, the fillet weld size required for strength is

$$\begin{aligned} w &\geq \frac{(R_{ust})_1 + (R_{ust})_2}{0.75 \times 0.6F_{EXX}(l - 2 \times clip) \times 2 \times \sqrt{2}} \\ &\geq \frac{82 \text{ kips}}{0.75 \times 0.6(70 \text{ ksi})(12.6 \text{ in.} - 2 \times 3/4 \text{ in.}) \times 2 \times \sqrt{2}} \\ &\geq 0.0829 \text{ in.} \end{aligned}$$

From LRFD Specification Table J2.4, the minimum weld size for the 1/2-in.-thick transverse stiffener, 3/8-in.-thick web doubler plate, and 0.440-in.-thick column web is 3/16 in. **Use 3/16-in. fillet welds.**

The 1/2-in. CJP groove weld must transmit one-half of the 82-kip unbalanced force in the transverse stiffeners (41 kips). From LRFD Specification Table J2.5, the shear strength is the lesser of that on the effective area in the transverse stiffener base metal and that in the weld itself. For the transverse stiffener base metal,

$$\begin{aligned} \phi R_n &= 0.9 \times 0.6F_{yst}w'(l - 2 \times clip) \\ &= 0.9 \times 0.6(36 \text{ ksi})(1/2 \text{ in.})(12.6 \text{ in.} - 2 \times 3/4 \text{ in.}) \\ &= 108 \text{ kips} > 41 \text{ kips} \quad \mathbf{o.k.} \end{aligned}$$

For the weld metal,

$$\begin{aligned} \phi R_n &= 0.8 \times 0.6F_{EXX}w'(l - 2 \times clip) \\ &= 0.8 \times 0.6(70 \text{ ksi})(1/2 \text{ in.})(12.6 \text{ in.} - 2 \times 3/4 \text{ in.}) \\ &= 186 \text{ kips} > 41 \text{ kips} \quad \mathbf{o.k.} \end{aligned}$$

For this detail, either the entire unbalanced force can be transmitted to the column web (through the two fillet welds on the side of the column web without a web doubler plate and the CJP groove weld) or the fillet weld between the web doubler plate and transverse stiffener can be sized to transmit a portion of this force to the web doubler plate.²² In the former case, the fillet weld between the web doubler plate and the transverse stiffener is selected as a minimum-size fillet weld per LRFD Specification

²²As in Solution A, the shear strength of the effective area at the root of the CJP groove weld can be used for force transfer to the web doubler plate, if necessary.

Table J2.4 (3/16-in.). For the column web, the design shear strength is

$$\begin{aligned} \phi R_n &= 0.9 \times 0.6F_yd_c t_w \\ &= 0.9 \times 0.6(50 \text{ ksi})(14.02 \text{ in.})(0.440 \text{ in.}) \\ &= 167 \text{ kips} > 82 \text{ kips} \quad \mathbf{o.k.} \end{aligned}$$

Therefore, the column web is adequate to transfer the entire unbalanced load to the panel zone without additional strength from the web doubler plate. The fillet weld between the web doubler plate and the transverse stiffener is selected as minimum size per LRFD Specification Section J2.4. **Use a 3/16-in. fillet weld.**

Solution D:

The transverse stiffeners are to be connected to the column panel zone with a detail that combines three fillet welds to the column web and one fillet weld to the web doubler plate as illustrated in Figure 4-11d. From Equation 4.3-10, the fillet weld size required for strength is

$$\begin{aligned} w &\geq \frac{(R_{ust})_1 + (R_{ust})_2}{0.75 \times 0.6F_{EXX}(l - 2 \times clip) \times 2 \times \sqrt{2}} \\ &\geq \frac{82 \text{ kips}}{0.75 \times 0.6(70 \text{ ksi})(12.6 \text{ in.} - 2 \times 3/4 \text{ in.}) \times 2 \times \sqrt{2}} \\ &\geq 0.0829 \text{ in.} \end{aligned}$$

From LRFD Specification Table J2.4, the minimum weld size for the 1/2-in.-thick transverse stiffener, 3/8-in.-thick web doubler plate, and 0.440-in.-thick column web is 3/16 in. **Use 3/16-in. fillet welds.**

The column web and web doubler plate thicknesses must also be checked for shear strength to transmit the unbalanced force in the transverse stiffeners to the panel-zone. For this detail, three-quarters of the unbalanced force (61.5 kips, the shear transmitted by the fillet welds) can be assigned to the column web with the remaining one-quarter (20.5 kips, the shear transmitted by the CJP groove weld) assigned to the web doubler plate. For the column web, the design shear strength is

$$\begin{aligned} \phi R_n &= 0.9 \times 0.6F_yd_c t_w \\ &= 0.9 \times 0.6(50 \text{ ksi})(14.02 \text{ in.})(0.440 \text{ in.}) \\ &= 167 \text{ kips} > 61.5 \text{ kips} \quad \mathbf{o.k.} \end{aligned}$$

For the web doubler plate, the design shear strength is

$$\begin{aligned} \phi R_n &= 0.9 \times 0.6F_{ydp}d_c t_{pl} \\ &= 0.9 \times 0.6(36 \text{ ksi})(14.02 \text{ in.})(3/8 \text{ in.}) \\ &= 102 \text{ kips} > 20.5 \text{ kips} \quad \mathbf{o.k.} \end{aligned}$$

Therefore, the column web and web doubler plate are of adequate thickness to provide for proper force transfer of the unbalance force in the transverse stiffener to the panel-zone.

Example 6-12

Given:

For a pair of $\frac{1}{2}$ -in.-thick full-depth transverse stiffeners ($F_y = 36$ ksi) that transmit an unbalanced force of 82 kips to a 0.440-in.-thick column web ($F_y = 50$ ksi) with two $\frac{3}{8}$ -in.-thick web doubler plates ($F_y = 36$ ksi), proportion the welds and check shear in the column web and web doubler plates. The transverse stiffeners are $1'-0\frac{9}{16}$ -in. long and have two $\frac{3}{4}$ -in. \times $\frac{3}{4}$ -in. corner clips each. They are used with a W14 \times 90 column. Use a joint detail as illustrated in:

- A) Figure 4-12a.
- B) Figure 4-12b.
- C) Figure 4-12c.
- D) Figure 4-12d.

Solution A:

Each transverse stiffener is to be connected to the column panel zone with a detail that combines one fillet weld and one CJP groove weld as illustrated in Figure 4-12a. From Equation 4.3-10, the fillet weld size required for strength is

$$\begin{aligned} w &\geq \frac{(R_{ust})_1 + (R_{ust})_2}{0.75 \times 0.6F_{EXX}(l - 2 \times clip) \times 2 \times \sqrt{2}} \\ &\geq \frac{82 \text{ kips}}{0.75 \times 0.6(70 \text{ ksi})(12.6 \text{ in.} - 2 \times \frac{3}{4} \text{ in.}) \times 2 \times \sqrt{2}} \\ &\geq 0.0829 \text{ in.} \end{aligned}$$

From LRFD Specification Table J2.4, the minimum weld size for the $\frac{1}{2}$ -in.-thick transverse stiffener, $\frac{3}{8}$ -in.-thick web doubler plate, and 0.440-in.-thick column web is $\frac{3}{16}$ in. **Use $\frac{3}{16}$ -in. fillet welds.**

The $\frac{3}{8}$ -in. CJP groove weld must transmit one-quarter of the 82-kip unbalanced force in the transverse stiffeners (20.5 kips). From LRFD Specification Table J2.5, the shear strength is the lesser of that on the effective area in the transverse stiffener base metal and that in the weld itself. For the transverse stiffener base metal,

$$\begin{aligned} \phi R_n &= 0.9 \times 0.6F_{yst}w'(l - 2 \times clip) \\ &= 0.9 \times 0.6(36 \text{ ksi})(\frac{3}{8} \text{ in.})(12.6 \text{ in.} - 2 \times \frac{3}{4} \text{ in.}) \\ &= 80.9 \text{ kips} > 20.5 \text{ kips} \quad \mathbf{o.k.} \end{aligned}$$

For the weld metal,

$$\begin{aligned} \phi R_n &= 0.8 \times 0.6F_{EXX}w'(l - 2 \times clip) \\ &= 0.8 \times 0.6(70 \text{ ksi})(\frac{3}{8} \text{ in.})(12.6 \text{ in.} - 2 \times \frac{3}{4} \text{ in.}) \\ &= 140 \text{ kips} > 20.5 \text{ kips} \quad \mathbf{o.k.} \end{aligned}$$

The column web and web doubler plate thicknesses must also be checked for shear strength to transmit the unbalanced force in the transverse stiffeners to the panel-zone. For this detail, one-half of the unbalanced force (41 kips, the shear transmitted by the fillet welds) can be assigned to the column web with one-quarter (20.5 kips, the shear transmitted by each CJP groove weld) assigned to each web doubler plate. For the column web, the design shear strength is

$$\begin{aligned} \phi R_n &= 0.9 \times 0.6F_yd_c t_w \\ &= 0.9 \times 0.6(50 \text{ ksi})(14.02 \text{ in.})(0.440 \text{ in.}) \\ &= 167 \text{ kips} > 41 \text{ kips} \quad \mathbf{o.k.} \end{aligned}$$

For the web doubler plate, the design shear strength is

$$\begin{aligned} \phi R_n &= 0.9 \times 0.6F_{ydp}d_c t_{pl} \\ &= 0.9 \times 0.6(36 \text{ ksi})(14.02 \text{ in.})(\frac{3}{8} \text{ in.}) \\ &= 102 \text{ kips} > 20.5 \text{ kips} \quad \mathbf{o.k.} \end{aligned}$$

Therefore, the column web and web doubler plates are of adequate thickness to provide for proper force transfer of the unbalance force in the transverse stiffeners to the panel-zone. If either the column web or the web doubler plate thickness were inadequate in the above calculations, shear transfer between these elements on the effective area of the CJP groove weld root area can be utilized as a load path. Note, however, that if force is to be transferred from the column web to the web doubler plate(s) in this manner, the maximum force transfer may be limited by the design shear strength on the effective area at the juncture between the CJP groove weld and the web doubler plate.

Solution B:

The solution for this example and the joint detail illustrated in Figure 4-12b is identical to Solution A.

Solution C:

Each transverse stiffener is to be connected to the column panel zone with a detail that combines one fillet weld and one CJP groove weld as illustrated in Figure 4-12c. The $\frac{1}{2}$ -in. CJP groove weld must transmit one-half of the 82-kip unbalanced force in the transverse stiffeners (41 kips). From LRFD Specification Table J2.5, the shear strength is the lesser of that on the effective area in the transverse stiffener base metal and that in the weld itself. For the transverse stiffener base metal,

$$\begin{aligned}\phi R_n &= 0.9 \times 0.6 F_{yst} w' (l - 2 \times clip) \\ &= 0.9 \times 0.6 (36 \text{ ksi}) (1/2 \text{ in.}) (12.6 \text{ in.} - 2 \times 3/4 \text{ in.}) \\ &= 108 \text{ kips} > 41 \text{ kips} \quad \mathbf{o.k.}\end{aligned}$$

For the weld metal,

$$\begin{aligned}\phi R_n &= 0.8 \times 0.6 F_{EXX} w' (l - 2 \times clip) \\ &= 0.8 \times 0.6 (70 \text{ ksi}) (1/2 \text{ in.}) (12.6 \text{ in.} - 2 \times 3/4 \text{ in.}) \\ &= 186 \text{ kips} > 41 \text{ kips} \quad \mathbf{o.k.}\end{aligned}$$

For this detail, either the entire unbalanced force can be transmitted to the column web (through the two CJP groove welds) or the fillet welds between the web doubler plates and transverse stiffeners can be sized to transmit a portion of this force to the web doubler plates.²³ In the former case, the fillet welds between the web doubler plates and the transverse stiffeners are selected as minimum-size fillet welds per LRFD Specification Table J2.4 ($3/16$ -in.). For the column web, the design shear strength is

$$\begin{aligned}\phi R_n &= 0.9 \times 0.6 F_y d_c t_w \\ &= 0.9 \times 0.6 (50 \text{ ksi}) (14.02 \text{ in.}) (0.440 \text{ in.}) \\ &= 167 \text{ kips} > 82 \text{ kips} \quad \mathbf{o.k.}\end{aligned}$$

Therefore, the column web is adequate to transfer the entire unbalanced load to the panel zone without additional strength from the web doubler plates. The fillet welds between the web doubler plates and the transverse stiffener are selected as minimum size per LRFD Specification Section J2.4. **Use a $3/16$ -in. fillet weld.**

Solution D:

The transverse stiffeners are to be connected to the column panel zone with a detail that combines two fillet welds to the column web and one fillet weld to each of the web doubler plates as illustrated in Figure 4-12d. From Equation 4.3-10, the fillet weld size required for strength is

$$\begin{aligned}w &\geq \frac{(R_{ust})_1 + (R_{ust})_2}{0.75 \times 0.6 F_{EXX} (l - 2 \times clip) \times 2 \times \sqrt{2}} \\ &\geq \frac{82 \text{ kips}}{0.75 \times 0.6 (70 \text{ ksi}) (12.6 \text{ in.} - 2 \times 3/4 \text{ in.}) \times 2 \times \sqrt{2}} \\ &\geq 0.0829 \text{ in.}\end{aligned}$$

²³As in Solution A, the shear strength of the effective area at the root of the CJP groove weld can be used for force transfer to the web doubler plate, if necessary.

From LRFD Specification Table J2.4, the minimum weld size for the $1/2$ -in.-thick transverse stiffener, $3/8$ -in.-thick web doubler plate, and 0.440-in.-thick column web is $3/16$ in. **Use $3/16$ -in. fillet welds.**

The column web and web doubler plate thicknesses must also be checked for shear strength to transmit the unbalanced force in the transverse stiffeners to the panel-zone. For this detail, one-half of the unbalanced force (41 kips, the shear transmitted by the fillet welds to the column web) can be assigned to the column web with the remaining one-quarter (20.5 kips, the shear transmitted by the fillet weld to each web doubler plate) assigned to each web doubler plate. For the column web, the design shear strength is

$$\begin{aligned}\phi R_n &= 0.9 \times 0.6 F_y d_c t_w \\ &= 0.9 \times 0.6 (50 \text{ ksi}) (14.02 \text{ in.}) (0.440 \text{ in.}) \\ &= 167 \text{ kips} > 41 \text{ kips} \quad \mathbf{o.k.}\end{aligned}$$

For the web doubler plate, the design shear strength is

$$\begin{aligned}\phi R_n &= 0.9 \times 0.6 F_{ydp} d_c t_{pl} \\ &= 0.9 \times 0.6 (36 \text{ ksi}) (14.02 \text{ in.}) (3/8 \text{ in.}) \\ &= 102 \text{ kips} > 20.5 \text{ kips} \quad \mathbf{o.k.}\end{aligned}$$

Therefore, the column web and web doubler plates are of adequate thickness to provide for proper force transfer of the unbalance force in the transverse stiffener to the panel-zone.

Example 6-13

Given:

Determine the transverse stiffener requirements and if a web doubler plate will be required for the high-seismic reduced beam section (RBS) connection illustrated in Figure 6-13 in a Special Moment Frame (SMF) or Intermediate Moment Frame (IMF). The axial compression in the column is 1,000 kips. The shear at the plastic hinge location is 150 kips. Neglect the effects of story shear for calculation purposes.

$$\begin{aligned}\text{W36} \times 150, F_y &= 50 \text{ ksi} \\ d &= 35.85 \text{ in.} \quad b_f = 11.975 \text{ in.} \quad Z_x = 581 \text{ in.}^3 \\ a &= 22.5 \text{ in.} \quad t_w = 0.625 \text{ in.} \quad t_f = 0.940 \text{ in.} \\ \text{W14} \times 426, F_y &= 50 \text{ ksi} \\ d &= 18.67 \text{ in.} \quad b_f = 16.695 \text{ in.} \quad k = 3^{11/16} \text{ in.} \\ k_1 &= 1^{9/16} \text{ in.} \quad t_w = 1.875 \text{ in.} \quad t_f = 3.035 \text{ in.} \\ T &= 11^{1/4} \text{ in.} \quad A = 125 \text{ in.}^2\end{aligned}$$

Use an RBS detail with a plastic section modulus $Z = 356 \text{ in.}^3$ (at RBS).

Solution:

Calculate the flange forces and panel-zone shear force:
 From Equation 2.1-2, the force at each flange need not be taken greater than

$$P_{uf} = \frac{1.1R_y F_y Z + V_u a}{d - t_f}$$

$$= \frac{1.1(1.1)(50 \text{ ksi})(356 \text{ in.}^3) + (150 \text{ kips})(22.5 \text{ in.})}{(35.85 \text{ in.} - 0.940 \text{ in.})}$$

$$= 714 \text{ kips}$$

Neglecting the effects of story shear, the panel-zone web shear force is determined from Equation 2.1-5 as

$$V_u = P_{uf} = 714 \text{ kips}$$

Determine the design panel-zone web shear strength:

In a high-seismic application, either Equation 2.2-5 or Equation 2.2-6 is used.

$$P_y = F_y A = (50 \text{ ksi})(125 \text{ in.}^2) = 6,250 \text{ kips}$$

$$\frac{P_u}{P_y} = \frac{1,000 \text{ kips}}{6,250 \text{ kips}} = 0.160$$

Since this ratio is less than 0.75, Equation 2.2-5 is applicable.

$$\phi R_v = 0.75 \times 0.6 F_y d_c t_w \left(1 + \frac{3 b_f t_f^2}{d_b d_c t_w} \right)$$

$$= 0.75 \times 0.6 (50 \text{ ksi})(18.67 \text{ in.})(1.875 \text{ in.})$$

$$\times \left(1 + \frac{3(16.695 \text{ in.})(3.035 \text{ in.})^2}{(35.85 \text{ in.})(18.67 \text{ in.})(1.875 \text{ in.})} \right)$$

$$= 1,080 \text{ kips} > V_u = 714 \text{ kips} \quad \mathbf{o.k.}$$

To prevent seismic shear buckling in the panel-zone, from Equation 2.2-7,

$$t_{w \min} = \frac{d_m + d_c - 2t_f}{90}$$

$$= \frac{(35.85 \text{ in.} - 0.940 \text{ in.}) + 18.67 \text{ in.} - 2(3.035 \text{ in.})}{90}$$

$$= 0.528 \text{ in.} < t_w = 1.875 \text{ in.} \quad \mathbf{o.k.}$$

Therefore, the web of the W14×426 is adequate to resist the panel-zone web shear without reinforcement.

Determine the transverse stiffener requirements:

As indicated in Section 2.3, transverse stiffeners are required to match the configuration used in the qualifying

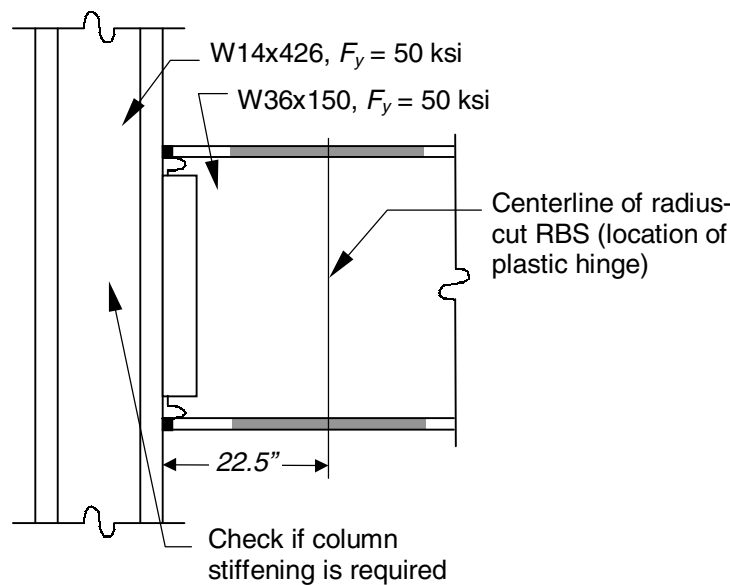

Figure 6-13 Framing arrangement for Example 6-13 (problem statement).

cyclic tests. From Engelhardt et al. (1998), a pair of full-depth transverse stiffeners at each flange with 1-in. thickness and 5-in. width is adequate. These transverse stiffeners are required for cross-sectional stiffness only, as the design strengths of the column flange and web to resist both tensile and compressive flange forces (see Table B-1) are well in excess of the required strength of 714 kips. The transverse stiffener length is selected as the column depth minus twice the flange thickness, which equals 1'-0⁹/₁₆ in. **Use 2 PL 1 in. × 5 in. × 1'-0⁹/₁₆ with two ³/₄-in. × ³/₄-in. corner clips each.**

Determine the welding requirements for the transverse stiffeners:

Complete-joint-penetration groove welds are used to connect the transverse stiffeners to the column flanges. **Use 1-in. CJP groove welds to connect the transverse stiffeners to the column flange.**

In lieu of calculating the force that must be transmitted from the transverse stiffeners to the column web, the double-sided fillet welds connecting the transverse stiffeners to the column web can be sized for the maximum force provisions given in Section 4.3. From Equation 4.3-17 (limit based upon the strength of the transverse stiffener ends in tension),

$$\begin{aligned}\phi R_{n \max} &= 0.9 F_{y st}(2)(b_s - clip) \times t_s \\ &= 0.9(36 \text{ ksi})(2)(5 \text{ in.} - \frac{3}{4} \text{ in.})(1 \text{ in.}) \\ &= 275 \text{ kips}\end{aligned}$$

From Equation 4.3-15 (limit based upon shear in the transverse stiffeners),

$$\begin{aligned}\phi R_{n \max} &= 0.9 \times 0.6 F_{y st}(l - 2 \times clip) \times 2 t_s \\ &= 0.9 \times 0.6(36 \text{ ksi})(12.6 \text{ in.} - 2 \times \frac{3}{4} \text{ in.}) \\ &\quad \times 2(1 \text{ in.}) \\ &= 432 \text{ kips}\end{aligned}$$

From Equation 4.3-16 (limit based upon shear in the column web, one shear plane used because the entire force must be transmitted into the panel-zone),

$$\begin{aligned}\phi R_{n \max} &= 0.9 \times 0.6 F_y d_c \times t_{pz} \\ &= 0.9 \times 0.6(50 \text{ ksi})(18.67 \text{ in.})(1.875 \text{ in.}) \\ &= 945 \text{ kips}\end{aligned}$$

Thus, the limit based upon the strength of the transverse stiffener ends in tension governs. From Equation 4.3-10 with the quantity $(R_{ust})_1 + (R_{ust})_2$ set equal to 275 kips,

$$\begin{aligned}w &\geq \frac{(R_{ust})_1 + (R_{ust})_2}{0.75 \times 0.6 F_{EXX}(l - 2 \times clip) \times 2 \times \sqrt{2}} \\ &\geq \frac{275 \text{ kips}}{0.75 \times 0.6(70 \text{ ksi})(12.6 \text{ in.} - 2 \times \frac{3}{4} \text{ in.}) \times 2 \times \sqrt{2}} \\ &\geq 0.278 \text{ in.}\end{aligned}$$

The minimum size fillet weld per LRFD Specification Table J2.4 is ⁵/₁₆ in. **Use ⁵/₁₆-in. double-sided fillet welds to connect the transverse stiffeners to the column web.**

Summary:

The W14×426 is adequate without a web doubler plate but requires the use of a pair of transverse stiffeners at the location of each beam flange. Use 4 PL 1 in. × 5 in. × 1'-0⁹/₁₆ with two ³/₄-in. × ³/₄-in. corner clips each, 1-in. CJP groove welds to connect the transverse stiffeners to the column flanges, and ⁵/₁₆-in. double-sided fillet welds to connect the transverse stiffeners to the column web. This column-stiffening configuration is illustrated in Figure 6-14.

Example 6-14

Given:

Determine the transverse stiffener requirements and if a web doubler plate will be required for the high-seismic reduced beam section (RBS) connections illustrated in Figure 6-15 in a Special Moment Frame (SMF) or Intermediate Moment Frame (IMF). The axial compression in the column is 1,200 kips. The shear at the plastic hinge location is 150 kips. Neglect the effects of story shear for calculation purposes.

$$\begin{aligned}\text{W36} \times 150, F_y &= 50 \text{ ksi} \\ d &= 35.85 \text{ in.} \quad b_f = 11.975 \text{ in.} \\ Z_x &= 581 \text{ in.}^3 \quad a = 22.5 \text{ in.} \\ t_w &= 0.625 \text{ in.} \quad t_f = 0.940 \text{ in.}\end{aligned}$$

$$\begin{aligned}\text{W14} \times 500, F_y &= 50 \text{ ksi} \\ d &= 19.60 \text{ in.} \quad b_f = 17.010 \text{ in.} \\ k &= 4\frac{3}{16} \text{ in.} \quad k_1 = 1\frac{3}{4} \text{ in.} \\ t_w &= 2.190 \text{ in.} \quad t_f = 3.500 \text{ in.} \\ T &= 11\frac{1}{4} \text{ in.} \quad A = 147 \text{ in.}^2\end{aligned}$$

Use an RBS detail with a plastic section modulus $Z = 356 \text{ in.}^3$ (at RBS).

Solution:

Calculate the flange forces and panel-zone shear force:
From Equation 2.1-2, the force at each flange need not be

taken greater than

$$\begin{aligned}
 P_{uf} &= \frac{1.1R_y F_y Z + V_u a}{d - t_f} \\
 &= \frac{1.1(1.1)(50 \text{ ksi})(356 \text{ in.}^3) + (150 \text{ kips})(22.5 \text{ in.})}{(35.85 \text{ in.} - 0.940 \text{ in.})} \\
 &= 714 \text{ kips}
 \end{aligned}$$

Neglecting the effects of story shear, the panel-zone web shear force is determined from Equation 2.1-4 as

$$\begin{aligned}
 V_u &= 0.8[(P_{uf})_1 + (P_{uf})_2] \\
 &= 0.8[714 \text{ kips} + 714 \text{ kips}] \\
 &= 1,140 \text{ kips}
 \end{aligned}$$

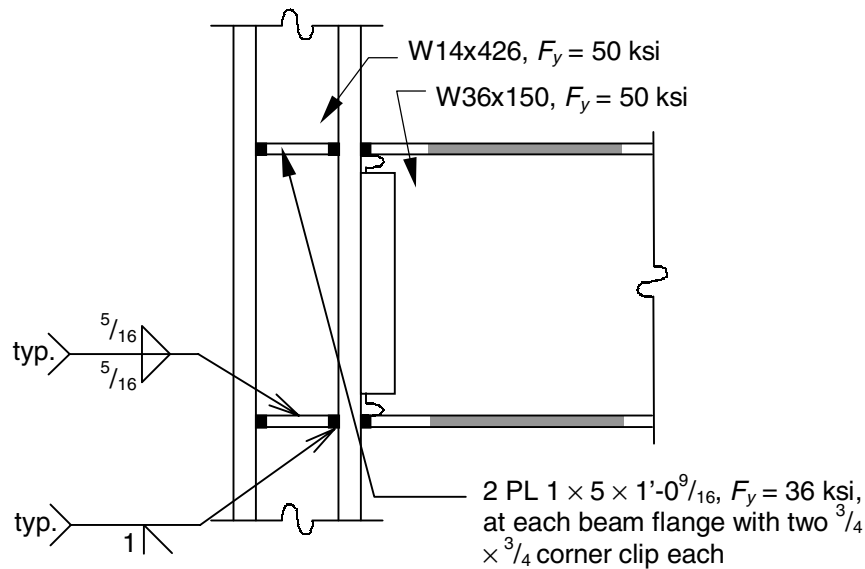

Figure 6-14 Framing arrangement for Example 6-13 (solution).

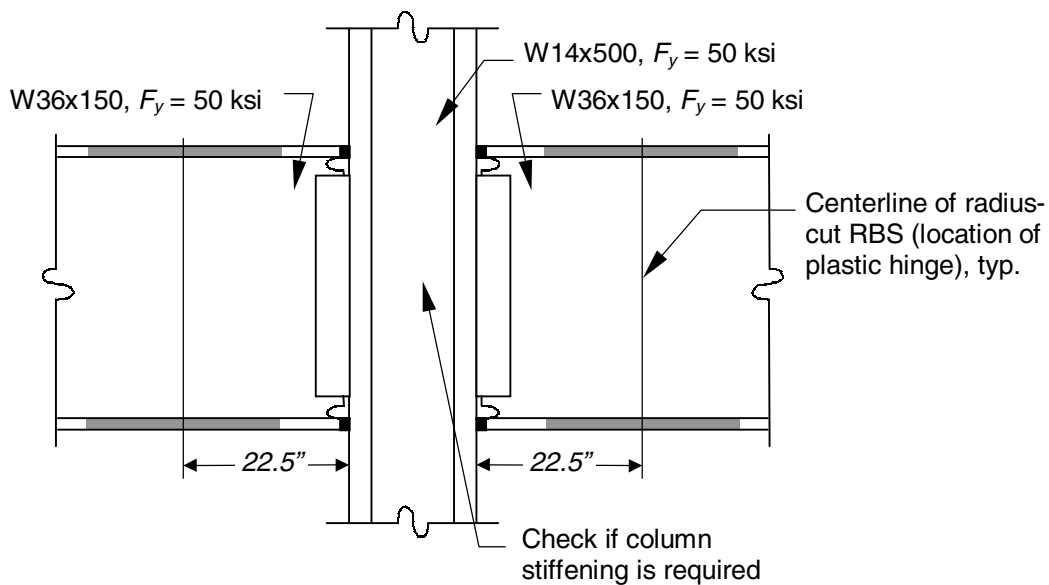

Figure 6-15 Framing arrangement for Example 6-14 (problem statement).

Determine the design panel-zone web shear strength:

In a high-seismic application, either Equation 2.2-5 or Equation 2.2-6 is used.

$$P_y = F_y A = (50 \text{ ksi})(147 \text{ in.}^2) = 7,350 \text{ kips}$$

$$\frac{P_u}{P_y} = \frac{1,200 \text{ kips}}{7,350 \text{ kips}} = 0.163$$

Since this ratio is less than 0.75, Equation 2.2-5 is applicable.

$$\begin{aligned} \phi R_v &= 0.75 \times 0.6 F_y d_c t_w \left(1 + \frac{3 b_f t_f^2}{d_b d_c t_w} \right) \\ &= 0.75 \times 0.6 (50 \text{ ksi})(19.60 \text{ in.})(2.190 \text{ in.}) \\ &\quad \times \left(1 + \frac{3(17.010 \text{ in.})(3.500 \text{ in.})^2}{(35.85 \text{ in.})(19.60 \text{ in.})(2.190 \text{ in.})} \right) \\ &= 1,360 \text{ kips} > V_u = 1,140 \text{ kips} \quad \mathbf{o.k.} \end{aligned}$$

To prevent seismic shear buckling in the panel-zone, from Equation 2.2-7,

$$\begin{aligned} t_{w \min} &= \frac{d_m + d_c - 2 t_f}{90} \\ &= \frac{(35.85 \text{ in.} - 0.940 \text{ in.}) + 19.60 \text{ in.} - 2(3.500 \text{ in.})}{90} \\ &= 0.528 \text{ in.} < t_w = 2.190 \text{ in.} \quad \mathbf{o.k.} \end{aligned}$$

Therefore, the web of the W14×500 is adequate to resist the panel-zone web shear without reinforcement.

Determine the transverse stiffener requirements:

As indicated in Section 2.3, transverse stiffeners are required to match the configuration used in the qualifying cyclic tests. From Engelhardt et al. (1998), a pair of full-depth transverse stiffeners at each flange with 1-in. thickness and 5-in. width is adequate (see Figure 6-7b). These transverse stiffeners are required for cross-sectional stiffness only as the design strengths of the column flange and web to resist both tensile and compressive flange forces (see Table B-1) are well in excess of the required strength of 714 kips. The transverse stiffener length is selected as the column depth minus twice the flange thickness, which equals 1'-0⁹/₁₆ in. **Use 2 PL 1 in. × 5 in. × 1'-0⁹/₁₆ with two ³/₄-in. × ³/₄-in. corner clips each.**

Determine the welding requirements for the transverse stiffeners:

Complete-joint-penetration groove welds are used to connect the transverse stiffeners to the column flanges. **Use**

1-in. CJP groove welds to connect the transverse stiffeners to the column flange.

In lieu of calculating the force that must be transmitted from the transverse stiffeners to the column web, the double-sided fillet welds connecting the transverse stiffeners to the column web can be sized for the maximum force provisions given in Section 4.3. From Equation 4.3-14 (limit based upon the strength of the transverse stiffener ends in tension),

$$\begin{aligned} \phi R_{n \max} &= 0.9 F_{yst}(4)(b_s - clip) \times t_s \\ &= 0.9(36 \text{ ksi})(4)(5 \text{ in.} - \frac{3}{4} \text{ in.})(1 \text{ in.}) \\ &= 551 \text{ kips} \end{aligned}$$

From Equation 4.3-15 (limit based upon shear in the transverse stiffeners),

$$\begin{aligned} \phi R_{n \max} &= 0.9 \times 0.6 F_{yst}(l - 2 \times clip) \times 2 t_s \\ &= 0.9 \times 0.6(36 \text{ ksi})(12.6 \text{ in.} - 2 \times 3\frac{3}{4} \text{ in.}) \\ &\quad \times 2(1 \text{ in.}) \\ &= 432 \text{ kips} \end{aligned}$$

From Equation 4.3-16 (limit based upon shear in the column web, one shear plane used because the entire force must be transmitted into the panel-zone),

$$\begin{aligned} \phi R_{n \max} &= 0.9 \times 0.6 F_y d_c \times t_{pz} \\ &= 0.9 \times 0.6(50 \text{ ksi})(19.60 \text{ in.})(1.875 \text{ in.}) \\ &= 992 \text{ kips} \end{aligned}$$

Thus, the limit based upon shear in the transverse stiffeners governs. From Equation 4.3-10 with the quantity $(R_{ust})_1 + (R_{ust})_2$ set equal to 432 kips,

$$\begin{aligned} w &\geq \frac{(R_{ust})_1 + (R_{ust})_2}{0.75 \times 0.6 F_{EXX}(l - 2 \times clip) \times 2 \times \sqrt{2}} \\ &\geq \frac{432 \text{ kips}}{0.75 \times 0.6(70 \text{ ksi})(12.6 \text{ in.} - 2 \times \frac{3}{4} \text{ in.}) \times 2 \times \sqrt{2}} \\ &\geq 0.437 \text{ in.} \sim \frac{7}{16} \text{ in.} \end{aligned}$$

The minimum size fillet weld per LRFD Specification Table J2.4 is ⁵/₁₆ in. **Use ⁷/₁₆-in. double-sided fillet welds to connect the transverse stiffeners to the column web.**

Summary:

The W14×500 is adequate without a web doubler plate but requires the use of a pair of transverse stiffeners at the location of each beam flange. Use 4 PL 1 in. × 5 in. × 1'-0⁹/₁₆ with two ³/₄-in. × ³/₄-in. corner clips each, 1-in. CJP groove welds to connect the transverse stiffeners to

the column flanges, and $\frac{7}{16}$ -in. double-sided fillet welds to connect the transverse stiffeners to the column web. This

column-stiffening configuration is illustrated in Figure 6-16.

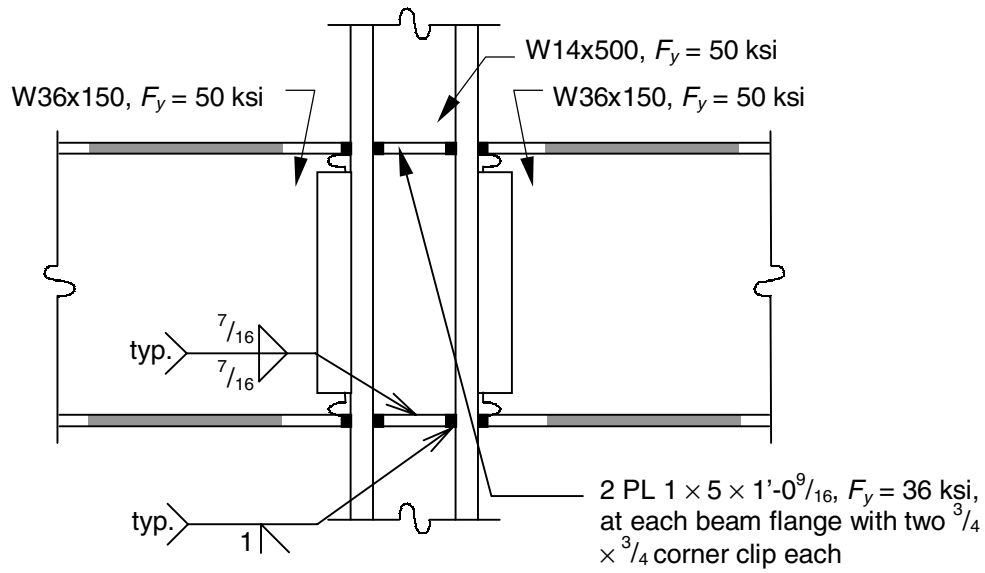

Figure 6-16 Framing arrangement for Example 6-14 (solution).

REFERENCES

- American Institute of Steel Construction, 1997a, *Seismic Provisions for Structural Steel Buildings*, AISC, Chicago, IL.
- American Institute of Steel Construction, 1997b, “k-area Advisory Statement,” *Modern Steel Construction*, February, AISC, Chicago, IL.
- American Institute of Steel Construction, 1994, *LRFD Manual of Steel Construction*, AISC, Chicago, IL.
- American Institute of Steel Construction, 1993, *LRFD Specification for Structural Steel Buildings*, AISC, Chicago, IL.
- American Institute of Steel Construction, 1989, *Specification for Structural Steel Buildings—Allowable Stress Design and Plastic Design*, AISC, Chicago, IL.
- Barger, B.L., 1992, “What Design Engineers Can Do to Reduce Fabrication Costs,” *Modern Steel Construction*, February, pp. 31-32, AISC, Chicago, IL.
- Blodgett, O.W., 1967, *Design of Welded Structures*, The Lincoln Electric Company, Cleveland, OH.
- Curtis, L.E. and Murray, T.M., 1989, “Column Flange Strength at Moment End-Plate Connections,” *Engineering Journal*, Vol. 26, No. 2, pp. 41-50, AISC, Chicago, IL.
- Disque, R.O., 1975, “Directional Moment Connections—A Proposed Design Method for Unbraced Steel Frames,” *Engineering Journal*, Vol. 12, No. 1, pp. 14-18, AISC, Chicago, IL.
- Driscoll, G.C. and Beedle, L.S., 1982, “Suggestions for Avoiding Beam-to-Column Web Connection Failures,” *Engineering Journal*, Vol. 19, No. 1, pp. 16-19, AISC, Chicago, IL.
- Driscoll, G.C., Pourbohloul, A., and Wang, X., 1983, “Fracture of Moment Connections—Tests on Simulated Beam-to-Column Web Moment Connection Details,” *Fritz Engineering Laboratory Report No. 469.7*, Lehigh University, Bethlehem, PA.
- Dyker, W.G., 1992, “What Design Engineers Can Do to Reduce Fabrication Costs,” *Modern Steel Construction*, February, pp. 28-29, AISC, Chicago, IL.
- El Tawil, S., Mikesell, T., Vidarsson, E., and Kunnath, S.K., 1998, *Strength and Ductility of FR Welded-Bolted Connections*, Report No. SAC/BD-98/01
- Engelhardt, M.D., Winneberger, T., Zekany, A.J., and Potyraj, T.J., 1998, “Experimental Investigation of Dogbone Connections,” *Engineering Journal*, Vol. 35, No. 4, pp. 128-139, AISC, Chicago, IL.
- Federal Emergency Management Agency, 1995, *FEMA 267 Interim Guidelines: Evaluation, Repair, Modification and Design of Steel Moment Frames*, FEMA, Washington, D.C. Note that this document is intended to be updated periodically. To date, one update has been issued: Federal Emergency Management Agency, 1998, *FEMA 267A Interim Guidelines Advisory No. 1—Supplement to FEMA 267*, FEMA, Washington, D.C.
- Ferrell, M.T., 1998, “Moment Connections to Column Webs,” *Proceedings of the 1998 AISC National Steel Construction Conference*, pp. 13.1-13.8, AISC, Chicago, IL.
- Graham, J.D., Sherbourne, A.N., Khabbaz, R.N., and Jensen, C.D., 1959, “Welded Interior Beam-to-Column Connections,” *Report for AISC*, AISC, Chicago, IL.
- Huang, J. S., W. F. Chen, and L. S. Beedle, 1973, “Behavior and Design of Steel Beam-to-Column Moment Connections,” *Bulletin 188*, October, Welding Research Council, New York, NY.
- Leon, R.T., Hoffman, J.J., and Staeger, T., 1996, *Partially Restrained Composite Connections*, AISC, Chicago, IL.
- Murray, T.M., 1990, *Extended End-Plate Moment Connections*, AISC, Chicago, IL.
- Ricker, D.T., 1992, “Value Engineering and Steel Economy,” *Modern Steel Construction*, February, pp. 22-26, AISC, Chicago, IL.
- Tamboli, A., 1999, *Handbook of Structural Steel Connection Design and Details*, McGraw-Hill, New York, NY.; see Chapter 2 by W. A. Thornton and T. Kane, pp. 128-143.
- Thornton, W.A., 1992, “Designing for Cost Efficient Fabrication,” *Modern Steel Construction*, February, pp. 12-20, AISC, Chicago, IL.
- Thornton, W.A., 1991, “Structural Arrangement for Cost Effective Fabrication and Erection,” *Proceedings of the 1991 AISC National Steel Construction Conference*, pp. 27.1-27.16, AISC, Chicago, IL.
- Viest, I.M., Colaco, J.P., Furlong, R.W., Griffis, L.G., Leon, R.T., and Wylie, L.A., 1998, *Composite Construction: Design for Buildings*, McGraw-Hill/ASCE, Reston, VA.

Appendix A

COLUMN PANEL-ZONE WEB SHEAR STRENGTH

For wind and low-seismic applications, Table A-1 aids in the determination of the panel-zone web shear strength for wide-flange columns with strong-axis directly welded flange, flange plated, and extended end-plate moment connections. For high-seismic applications, see AISC (1997a). All values are given to three significant figures.

For a given W-shape, the table is entered under the appropriate values of $P_u/(F_y A_g)$ to determine the design shear strength of the column web. The tabulated values are for material with $F_y = 50$ ksi.

For values of $P_u/(F_y A_g)$ that are less than or equal to 0.4, the tabulated design strength is determined from LRFD Specification Equation K1-9, where:

$$\phi R_v = 0.9 \times 0.6 F_y d t_w$$

For values of $P_u/(F_y A_g)$ that are greater than 0.4, the tabulated design strength is determined from LRFD Specification Equation K1-10, where:

$$\phi R_v = 0.9 \times 0.6 F_y d t_w \left(1.4 - \frac{P_u}{F_y A_g} \right)$$

The design strength at intermediate values of $P_u/(F_y A_g)$ can be determined by linear interpolation.²⁴ In the above discussion and equations,

P_u = column factored axial force, kips

F_y = column specified minimum yield strength, ksi

A_g = column gross area, in.²

d = column depth, in.

t_w = column web thickness, in.

The tabulated design strengths are based upon the “first-yield” strength provisions in LRFD Specification Section K1.7(a) and will be conservative for the “post-yield” strength provisions in LRFD Specification Section K1.7(b). Alternatively, a higher design strength can be determined by calculation with the latter provisions.

²⁴Note that the value determined by linear interpolations between tabulated values will be approximate, since the equations used to generate the tabulated values are not necessarily linear.

Table A-1
Panel-Zone Web Shear Strength for Wide-Flange Columns, $F_y = 50$ ksi
(Wind and Low-Seismic Applications, see Section 1.4)

Shape	Design Panel-Zone Shear Strength ϕR_v , kips												
	$P_u/(F_y A)$												
	≤ 0.4	0.45	0.5	0.55	0.6	0.65	0.7	0.75	0.8	0.85	0.9	0.95	1
W44 × 335	1210	1150	1090	1030	970	909	849	788	727	667	606	546	485
× 290	1020	973	922	871	820	768	717	666	615	564	512	461	410
× 262	924	878	831	785	739	693	647	600	554	508	462	416	370
× 230	823	781	740	699	658	617	576	535	494	452	411	370	329
W40 × 593	2080	1970	1870	1770	1660	1560	1450	1350	1250	1140	1040	935	831
× 503	1750	1660	1570	1490	1400	1310	1220	1140	1050	962	874	787	699
× 431	1490	1420	1340	1270	1190	1120	1050	970	896	821	746	672	597
× 372	1270	1210	1150	1080	1020	954	891	827	764	700	636	573	509
× 321	1080	1030	974	920	866	812	758	703	649	595	541	487	433
× 297	1000	950	900	850	800	750	700	650	600	550	500	450	400
× 277	889	845	801	756	712	667	623	578	534	489	445	400	356
× 249	797	758	718	678	638	598	558	518	478	439	399	359	319
× 215	684	650	616	581	547	513	479	445	410	376	342	308	274
× 199	679	645	611	577	543	509	475	441	407	373	339	305	271
× 174	670	637	603	570	536	503	469	436	402	369	335	302	268
W40 × 466	1910	1820	1720	1630	1530	1440	1340	1240	1150	1050	957	861	765
× 392	1590	1510	1430	1360	1280	1200	1120	1040	956	877	797	717	638
× 331	1340	1280	1210	1140	1080	1010	941	873	806	739	672	605	537
× 278	1110	1050	995	940	885	830	774	719	664	608	553	498	442
× 264	1040	985	933	881	829	778	726	674	622	570	518	467	415
× 235	889	845	801	756	712	667	623	578	534	489	445	400	356
× 211	797	757	718	678	638	598	558	518	478	438	399	359	319
× 183	684	650	616	581	547	513	479	445	410	376	342	308	274
× 167	677	643	610	576	542	508	474	440	406	372	339	305	271
× 149	650	617	585	552	520	487	455	422	390	357	325	292	260
W36 × 848	2890	2740	2600	2460	2310	2170	2020	1880	1730	1590	1440	1300	1160
× 798	2700	2560	2430	2290	2160	2020	1890	1750	1620	1480	1350	1210	1080
× 650	2150	2050	1940	1830	1720	1610	1510	1400	1290	1180	1080	969	861
× 527	1700	1620	1530	1450	1360	1280	1190	1110	1020	937	852	767	682
× 439	1410	1340	1260	1190	1120	1050	983	913	843	773	702	632	562
× 393	1250	1180	1120	1060	996	934	872	809	747	685	623	560	498
× 359	1130	1070	1020	961	905	848	792	735	679	622	565	509	452
× 328	1020	970	919	868	817	766	715	664	613	562	511	460	409
× 300	937	891	844	797	750	703	656	609	562	516	469	422	375
× 280	873	829	785	742	698	654	611	567	524	480	436	393	349
× 260	822	781	740	699	658	617	576	535	493	452	411	370	329
× 245	779	740	701	662	623	584	546	507	468	429	390	351	312
× 230	737	700	663	626	589	553	516	479	442	405	368	332	295
W36 × 256	970	922	873	825	776	728	679	631	582	534	485	437	388
× 232	872	828	785	741	698	654	610	567	523	480	436	392	349
× 210	822	781	740	699	658	617	576	534	493	452	411	370	329
× 194	754	716	678	641	603	565	528	490	452	415	377	339	301
× 182	711	676	640	604	569	533	498	462	427	391	356	320	284
× 170	664	631	598	564	531	498	465	432	398	365	332	299	266
× 160	632	600	569	537	506	474	442	411	379	348	316	284	253
× 150	605	575	544	514	484	454	423	393	363	333	302	272	242
× 135	576	547	518	490	461	432	403	374	346	317	288	259	230

Table A-1 (cont'd)
Panel-Zone Web Shear Strength for Wide-Flange Columns, $F_y = 50$ ksi
(Wind and Low-Seismic Applications, see Section 1.4)

Shape	Design Panel-Zone Shear Strength ϕR_v , kips												
	$P_u/(F_y A)$												
	≤ 0.4	0.45	0.5	0.55	0.6	0.65	0.7	0.75	0.8	0.85	0.9	0.95	1
W33 ×354	1110	1060	1000	946	891	835	779	724	668	612	557	501	445
×318	987	938	889	839	790	740	691	642	592	543	494	444	395
×291	903	858	813	768	722	677	632	587	542	497	452	406	361
×263	811	771	730	689	649	608	568	527	487	446	406	365	324
×241	766	728	689	651	613	574	536	498	460	421	383	345	306
×221	710	674	639	603	568	532	497	461	426	390	355	319	284
×201	650	618	585	553	520	488	455	423	390	358	325	293	260
W33 ×169	612	581	551	520	489	459	428	398	367	336	306	275	245
×152	574	545	517	488	459	431	402	373	345	316	287	258	230
×141	544	517	490	462	435	408	381	354	326	299	272	245	218
×130	518	492	466	440	415	389	363	337	311	285	259	233	207
×118	488	464	439	415	390	366	342	317	293	268	244	220	195
W30 ×477	1510	1430	1360	1280	1200	1130	1050	979	903	828	753	678	602
×391	1220	1160	1100	1040	975	914	853	792	731	670	609	548	487
×326	997	947	898	848	798	748	698	648	598	548	499	449	399
×292	882	837	793	749	705	661	617	573	529	485	441	397	353
×261	794	754	714	675	635	595	556	516	476	437	397	357	317
×235	701	666	631	596	561	526	491	456	421	386	351	316	281
×211	647	615	583	550	518	486	453	421	388	356	324	291	259
×191	588	559	529	500	471	441	412	382	353	323	294	265	235
×173	538	511	484	458	431	404	377	350	323	296	269	242	215
W30 ×148	538	511	484	458	431	404	377	350	323	296	269	242	215
×132	503	478	453	428	403	377	352	327	302	277	252	226	201
×124	477	453	429	405	381	357	334	310	286	262	238	214	191
×116	458	435	412	389	366	343	320	298	275	252	229	206	183
×108	439	417	395	373	351	329	307	285	263	241	219	198	176
×99	416	395	375	354	333	312	291	271	250	229	208	187	167
×90	375	356	337	319	300	281	262	244	225	206	187	169	150
W27 ×539	1730	1640	1560	1470	1380	1300	1210	1120	1040	951	865	778	692
×448	1400	1330	1260	1190	1120	1050	980	910	840	770	700	630	560
×368	1130	1080	1020	962	906	849	793	736	679	623	566	510	453
×307	927	881	835	788	742	696	649	603	556	510	464	417	371
×258	767	728	690	652	613	575	537	498	460	422	383	345	307
×235	704	669	634	599	563	528	493	458	423	387	352	317	282
×217	637	605	573	542	510	478	446	414	382	350	319	287	255
×194	569	541	512	484	455	427	398	370	342	313	285	256	228
×178	544	517	490	463	436	408	381	354	327	299	272	245	218
×161	492	467	442	418	393	369	344	320	295	270	246	221	197
×146	447	425	403	380	358	335	313	291	268	246	224	201	179
W27 ×129	455	432	410	387	364	341	319	296	273	250	228	205	182
×114	420	399	378	357	336	315	294	273	252	231	210	189	168
×102	377	358	339	320	301	283	264	245	226	207	188	170	151
×94	356	338	321	303	285	267	249	231	214	196	178	160	142
×84	332	315	299	282	265	249	232	216	199	182	166	149	133

Table A-1 (cont'd)
Panel-Zone Web Shear Strength for Wide-Flange Columns, $F_y = 50$ ksi
(Wind and Low-Seismic Applications, see Section 1.4)

Shape	Design Panel-Zone Shear Strength ϕR_v , kips												
	$P_u/(F_y A)$												
	≤ 0.4	0.45	0.5	0.55	0.6	0.65	0.7	0.75	0.8	0.85	0.9	0.95	1
W24 ×492	1580	1500	1420	1340	1260	1180	1100	1030	946	867	789	710	631
×408	1270	1210	1140	1080	1020	954	890	826	763	699	636	572	509
×335	1030	974	923	872	820	769	718	667	615	564	513	461	410
×279	837	795	753	712	670	628	586	544	502	460	419	377	335
×250	740	703	666	629	592	555	518	481	444	407	370	333	296
×229	674	641	607	573	540	506	472	438	405	371	337	303	270
×207	604	574	544	513	483	453	423	393	362	332	302	272	242
×192	557	529	501	473	446	418	390	362	334	306	279	251	223
×176	511	486	460	434	409	383	358	332	307	281	256	230	204
×162	476	452	428	404	381	357	333	309	286	262	238	214	190
×146	434	412	391	369	347	326	304	282	261	239	217	195	174
×131	400	380	360	340	320	300	280	260	240	220	200	180	160
×117	360	342	324	306	288	270	252	234	216	198	180	162	144
×104	325	309	292	276	260	244	227	211	195	179	162	146	130
W24 ×103	364	346	328	310	291	273	255	237	219	200	182	164	146
×94	338	321	304	287	270	254	237	220	203	186	169	152	135
×84	306	291	275	260	245	229	214	199	183	168	153	138	122
×76	284	270	256	242	227	213	199	185	171	156	142	128	114
×68	266	253	239	226	213	199	186	173	160	146	133	120	106
W24 ×62	276	262	248	234	220	207	193	179	165	152	138	124	110
×55	251	239	226	214	201	189	176	163	151	138	126	113	101
W21 ×201	566	538	509	481	453	424	396	368	340	311	283	255	226
×182	509	484	458	433	407	382	356	331	305	280	255	229	204
×166	455	432	410	387	364	341	319	296	273	250	228	205	182
×147	429	407	386	365	343	322	300	279	257	236	214	193	172
×132	383	364	345	326	306	287	268	249	230	211	192	172	153
×122	351	334	316	299	281	263	246	228	211	193	176	158	140
×111	319	303	287	272	256	240	224	208	192	176	160	144	128
×101	288	274	260	245	231	216	202	187	173	159	144	130	115
W21 ×93	339	322	305	288	271	254	237	220	203	186	169	152	135
×83	298	283	268	253	238	223	209	194	179	164	149	134	119
×73	261	248	235	222	209	196	183	170	157	144	130	117	104
×68	245	233	221	209	196	184	172	159	147	135	123	110	98.1
×62	227	215	204	193	181	170	159	147	136	125	113	102	90.7
W21 ×57	230	219	207	196	184	173	161	150	138	127	115	104	92
×50	214	203	192	182	171	160	150	139	128	118	107	96	85
×44	195	185	176	166	156	146	137	127	117	107	98	88	78
W18 ×311	916	870	824	779	733	687	641	595	550	504	458	412	366
×283	826	785	743	702	661	619	578	537	496	454	413	372	330
×258	742	705	667	630	593	556	519	482	445	408	371	334	297
×234	660	627	594	561	528	495	462	429	396	363	330	297	264
×211	592	562	532	503	473	444	414	385	355	325	296	266	237
×192	527	501	475	448	422	396	369	343	316	290	264	237	211
×175	482	457	433	409	385	361	337	313	289	265	241	217	193
×158	431	410	388	367	345	323	302	280	259	237	216	194	173
×143	384	365	346	327	307	288	269	250	230	211	192	173	154
130	348	331	313	296	279	261	244	226	209	192	174	157	139

Table A-1 (cont'd)
Panel-Zone Web Shear Strength for Wide-Flange Columns, $F_y = 50$ ksi
(Wind and Low-Seismic Applications, see Section 1.4)

Shape	Design Panel-Zone Shear Strength ϕR_v , kips												
	$P_u/(F_y A)$												
	≤ 0.4	0.45	0.5	0.55	0.6	0.65	0.7	0.75	0.8	0.85	0.9	0.95	1
W18×119	335	319	302	285	268	252	235	218	201	185	168	151	134
×106	298	283	269	254	239	224	209	194	179	164	149	134	119
×97	269	255	242	228	215	201	188	175	161	148	134	121	107
×86	238	226	215	203	191	179	167	155	143	131	119	107	95.3
×76	209	199	188	178	167	157	146	136	125	115	104	94.0	83.6
W18×71	247	235	222	210	197	185	173	160	148	136	123	111	98.7
×65	223	212	201	190	178	167	156	145	134	123	111	100	89.2
×60	204	194	184	174	164	153	143	133	123	112	102	92.0	81.8
×55	191	181	172	162	153	143	133	124	114	105	95.3	85.8	76.3
×50	172	164	155	147	138	129	121	112	103	94.8	86.2	77.6	69.0
W18×46	176	167	158	149	140	132	123	114	105	97	88	79	70
×40	152	145	137	129	122	114	107	99	91	84	76	69	61
×35	143	136	129	122	115	108	100	93	86	79	72	65	57
W16×100	268	255	241	228	214	201	188	174	161	147	134	121	107
×89	237	226	214	202	190	178	166	154	142	131	119	107	95.0
×77	203	193	183	173	162	152	142	132	122	112	101	91.3	81.2
×67	174	165	157	148	139	131	122	113	104	95.8	87.1	78.4	69.7
W16×57	191	181	172	162	153	143	134	124	114	105	95.4	85.8	76.3
×50	167	158	150	142	133	125	117	108	100	91.8	83.4	75.1	66.7
×45	150	143	135	128	120	113	105	97.7	90.2	82.6	75.1	67.6	60.1
×40	132	125	119	112	105	98.9	92.3	85.7	79.1	72.5	65.9	59.3	52.7
×36	126	120	114	107	101	94.7	88.4	82.1	75.8	69.5	63.2	56.8	50.5
W16×31	118	112	106	100	94.3	88.4	82.5	76.6	70.7	64.8	59.0	53.1	47.2
×26	106	101	95.3	90.0	84.7	79.4	74.1	68.8	63.5	58.2	53.0	47.7	42.4
W14×808	2310	2190	2080	1960	1850	1730	1610	1500	1380	1270	1150	1040	923
×730	1860	1770	1670	1580	1490	1390	1300	1210	1120	1020	929	836	743
×665	1650	1570	1490	1410	1320	1240	1160	1080	992	909	827	744	661
×605	1470	1390	1320	1250	1170	1100	1030	953	879	806	733	660	586
×550	1300	1240	1170	1110	1040	975	910	845	780	715	650	585	520
×500	1160	1100	1040	985	927	869	811	753	695	637	579	522	464
×455	1030	983	931	880	828	776	724	673	621	569	517	466	414
W14×426	945	898	851	803	756	709	662	614	567	520	473	425	378
×398	874	830	787	743	699	656	612	568	524	481	437	393	350
×370	801	761	721	681	641	601	561	520	480	440	400	360	320
×342	729	693	656	620	583	547	511	474	438	401	365	328	292
×311	652	619	587	554	521	489	456	424	391	358	326	293	261
×283	583	554	525	496	466	437	408	379	350	321	292	262	233
×257	520	494	468	442	416	390	364	338	312	286	260	234	208
×233	463	440	417	394	371	348	324	301	278	255	232	209	185
×211	416	395	374	354	333	312	291	270	250	229	208	187	166
×193	372	353	335	316	298	279	260	242	223	205	186	167	149
×176	341	324	307	290	273	256	239	222	205	188	171	153	136
×159	301	286	271	256	241	226	211	196	181	166	151	136	121
×145	271	258	244	231	217	204	190	176	163	149	136	122	109

Table A-1 (cont'd)
Panel-Zone Web Shear Strength for Wide-Flange Columns, $F_y = 50$ ksi
(Wind and Low-Seismic Applications, see Section 1.4)

Shape	Design Panel-Zone Shear Strength ϕR_v , kips												
	$P_u/(F_y A)$												
	≤ 0.4	0.45	0.5	0.55	0.6	0.65	0.7	0.75	0.8	0.85	0.9	0.95	1
W14 ×132 ×120 ×109 ×99 ×90	255	243	230	217	204	191	179	166	153	140	128	115	102
	231	219	208	196	185	173	161	150	138	127	115	104	92.3
	203	193	183	173	162	152	142	132	122	112	101	91.3	81.2
	185	176	167	158	148	139	130	121	111	102	92.7	83.4	74.2
	167	158	150	142	133	125	117	108	100	91.6	83.3	75.0	66.6
W14 ×82 ×74 ×68 ×61	197	187	177	167	158	148	138	128	118	108	98.5	88.7	78.8
	172	164	155	146	138	129	121	112	103	94.7	86.1	77.5	68.9
	157	149	142	134	126	118	110	102	94.4	86.5	78.7	70.8	62.9
	141	134	127	120	113	105	98.4	91.4	84.4	77.3	70.3	63.3	56.3
W14 ×53 ×48 ×43	139	132	125	118	111	104	97.3	90.4	83.4	76.5	69.5	62.6	55.6
	127	120	114	108	101	94.9	88.6	82.3	76.0	69.6	63.3	57.0	50.6
	112	107	101	95.6	90.0	84.4	78.7	73.1	67.5	61.9	56.2	50.6	45.0
W14 ×38 ×34 ×30	118	112	106	100	94.4	88.5	82.6	76.7	70.8	64.9	59.0	53.1	47.2
	108	102	96.8	91.4	86.1	80.7	75.3	69.9	64.5	59.2	53.8	48.4	43.0
	101	95.8	90.8	85.8	80.7	75.7	70.6	65.6	60.5	55.5	50.4	45.4	40.4
W14 ×26 ×22	95.8	91.0	86.2	81.4	76.6	71.8	67.0	62.3	57.5	52.7	47.9	43.1	38.3
	85.3	81.1	76.8	72.5	68.3	64.0	59.7	55.5	51.2	46.9	42.7	38.4	34.1
W12 ×336 ×305 ×279 ×252 ×230 ×210 ×190 ×170 ×152 ×136 ×120 ×106 ×96 ×87 ×79 ×72 ×65	806	766	725	685	645	605	564	524	484	443	403	363	322
	716	680	644	609	573	537	501	465	430	394	358	322	286
	655	622	589	557	524	491	458	426	393	360	327	295	262
	580	551	522	493	464	435	406	377	348	319	290	261	232
	522	496	470	444	418	392	366	339	313	287	261	235	209
	469	445	422	398	375	351	328	305	281	258	234	211	187
	412	391	370	350	329	309	288	268	247	226	206	185	165
	364	345	327	309	291	273	255	236	218	200	182	164	145
	322	306	290	274	258	242	225	209	193	177	161	145	129
	286	272	257	243	229	215	200	186	172	157	143	129	114
	252	239	226	214	201	189	176	163	151	138	126	113	101
	212	202	191	180	170	159	149	138	127	117	106	95.5	84.9
	189	179	170	160	151	142	132	123	113	104	94.4	84.9	75.5
	174	166	157	148	139	131	122	113	105	95.8	87.1	78.4	69.7
	157	149	141	134	126	118	110	102	94.3	86.4	78.6	70.7	62.8
	142	135	128	121	114	107	100	92.4	85.3	78.2	71.1	64.0	56.9
128	121	115	108	102	95.7	89.3	83.0	76.6	70.2	63.8	57.4	51.0	
W12 ×58 ×53	118	113	107	101	94.8	88.9	82.9	77.0	71.1	65.2	59.2	53.3	47.4
	112	107	101	95.5	89.9	84.3	78.6	73.0	67.4	61.8	56.2	50.6	44.9
W12 ×50 ×45 ×40	122	116	110	104	97.4	91.3	85.2	79.2	73.1	67.0	60.9	54.8	48.7
	109	104	98.2	92.7	87.3	81.8	76.4	70.9	65.4	60.0	54.5	49.1	43.6
	95.1	90.3	85.6	80.8	76.1	71.3	66.6	61.8	57.1	52.3	47.6	42.8	38.0
W12 ×35 ×30 ×26	101	96.2	91.1	86.1	81.0	75.9	70.9	65.8	60.8	55.7	50.6	45.6	40.5
	86.6	82.3	78.0	73.6	69.3	65.0	60.6	56.3	52.0	47.6	43.3	39.0	34.7
	75.9	72.1	68.3	64.5	60.7	56.9	53.1	49.3	45.5	41.7	37.9	34.1	30.4
W12 ×22 ×19 ×16 ×14	86.4	82.1	77.8	73.5	69.1	64.8	60.5	56.2	51.8	47.5	43.2	38.9	34.6
	77.2	73.3	69.4	65.6	61.7	57.9	54.0	50.2	46.3	42.4	38.6	34.7	30.9
	71.2	67.7	64.1	60.5	57.0	53.4	49.9	46.3	42.7	39.2	35.6	32.0	28.5
	64.3	61.1	57.9	54.7	51.5	48.2	45.0	41.8	38.6	35.4	32.2	28.9	25.7

Table A-1 (cont'd)
Panel-Zone Web Shear Strength for Wide-Flange Columns, $F_y = 50$ ksi
(Wind and Low-Seismic Applications, see Section 1.4)

Shape	Design Panel-Zone Shear Strength ϕR_v , kips												
	$P_u/(F_y A)$												
	≤ 0.4	0.45	0.5	0.55	0.6	0.65	0.7	0.75	0.8	0.85	0.9	0.95	1
W10 ×112 ×100 ×88 ×77 ×68 ×60 ×54 ×49	232	220	208	197	185	174	162	151	139	127	116	104	92.6
	204	194	183	173	163	153	143	132	122	112	102	91.7	81.5
	177	168	159	151	142	133	124	115	106	97.4	88.5	79.7	70.8
	152	144	137	129	121	114	106	98.6	91.0	83.4	75.8	68.3	60.7
	132	125	119	112	106	99.0	92.4	85.8	79.2	72.6	66.0	59.4	52.8
	116	110	104	98.5	92.7	86.9	81.1	75.3	69.5	63.7	57.9	52.2	46.4
	101	95.8	90.7	85.7	80.6	75.6	70.6	65.5	60.5	55.4	50.4	45.4	40.3
	91.6	87.0	82.5	77.9	73.3	68.7	64.1	59.6	55.0	50.4	45.8	41.2	36.6
W10 ×45 ×39 ×33	95.4	90.7	85.9	81.1	76.4	71.6	66.8	62.0	57.3	52.5	47.7	43.0	38.2
	84.4	80.2	75.9	71.7	67.5	63.3	59.1	54.8	50.6	46.4	42.2	38.0	33.7
	76.2	72.4	68.6	64.8	60.9	57.1	53.3	49.5	45.7	41.9	38.1	34.3	30.5
W10 ×30 ×26 ×22	84.8	80.6	76.3	72.1	67.8	63.6	59.4	55.1	50.9	46.6	42.4	38.2	33.9
	72.5	68.9	65.3	61.6	58.0	54.4	50.8	47.1	43.5	39.9	36.3	32.6	29.0
	65.9	62.6	59.3	56.0	52.7	49.4	46.1	42.8	39.5	36.2	33.0	29.7	26.4
W10 ×19 ×17 ×15 ×12	69.1	65.7	62.2	58.8	55.3	51.8	48.4	44.9	41.5	38.0	34.6	31.1	27.6
	65.5	62.2	59.0	55.7	52.4	49.1	45.9	42.6	39.3	36.0	32.8	29.5	26.2
	62.0	58.9	55.8	52.7	49.6	46.5	43.4	40.3	37.2	34.1	31.0	27.9	24.8
	50.6	48.1	45.6	43.0	40.5	38.0	35.4	32.9	30.4	27.8	25.3	22.8	20.3
W8 ×67 ×58 ×48 ×40 ×35 ×31	139	132	125	118	111	104	97.0	90.0	83.1	76.2	69.3	62.3	55.4
	120	114	108	102	96.4	90.4	84.3	78.3	72.3	66.3	60.2	54.2	48.2
	91.8	87.2	82.6	78.0	73.4	68.9	64.3	59.7	55.1	50.5	45.9	41.3	36.7
	80.2	76.2	72.2	68.2	64.2	60.1	56.1	52.1	48.1	44.1	40.1	36.1	32.1
	68.0	64.6	61.2	57.8	54.4	51.0	47.6	44.2	40.8	37.4	34.0	30.6	27.2
	61.6	58.5	55.4	52.3	49.2	46.2	43.1	40.0	36.9	33.9	30.8	27.7	24.6
W8 ×28 ×24	62.0	58.9	55.8	52.7	49.6	46.5	43.4	40.3	37.2	34.1	31.0	27.9	24.8
	52.5	49.8	47.2	44.6	42.0	39.3	36.7	34.1	31.5	28.9	26.2	23.6	21.0
W8 ×21 ×18	55.9	53.1	50.3	47.5	44.7	41.9	39.1	36.3	33.5	30.7	27.9	25.2	22.4
	50.5	48.0	45.5	43.0	40.4	37.9	35.4	32.9	30.3	27.8	25.3	22.7	20.2
W8 ×15 ×13 ×10	53.6	51.0	48.3	45.6	42.9	40.2	37.6	34.9	32.2	29.5	26.8	24.1	21.5
	49.6	47.1	44.7	42.2	39.7	37.2	34.7	32.3	29.8	27.3	24.8	22.3	19.8
	36.2	34.4	32.6	30.8	29.0	27.2	25.4	23.5	21.7	19.9	18.1	16.3	14.5
W6 ×25 ×20 ×15	55.1	52.4	49.6	46.9	44.1	41.3	38.6	35.8	33.1	30.3	27.6	24.8	22.0
	43.5	41.3	39.2	37.0	34.8	32.6	30.5	28.3	26.1	23.9	21.8	19.6	17.4
	37.2	35.3	33.5	31.6	29.8	27.9	26.0	24.2	22.3	20.5	18.6	16.7	14.9
W6 ×16 ×12 ×9	44.1	41.9	39.7	37.5	35.3	33.1	30.9	28.7	26.5	24.2	22.0	19.8	17.6
	37.4	35.6	33.7	31.8	30.0	28.1	26.2	24.3	22.5	20.6	18.7	16.9	15.0
	27.1	25.7	24.4	23.0	21.7	20.3	19.0	17.6	16.2	14.9	13.5	12.2	10.8
W5 ×19 ×16	37.5	35.7	33.8	31.9	30.0	28.2	26.3	24.4	22.5	20.6	18.8	16.9	15.0
	32.5	30.8	29.2	27.6	26.0	24.3	22.7	21.1	19.5	17.9	16.2	14.6	13.0
W4 ×13	31.4	29.9	28.3	26.7	25.2	23.6	22.0	20.4	18.9	17.3	15.7	14.2	12.6

Appendix B

LOCAL COLUMN STRENGTH AT AN INTERMEDIATE LOCATION ALONG A WIDE-FLANGE COLUMN

For wind and low-seismic applications, Table B-1 aids in the determination of the local column strength at intermediate column locations²⁵ for wide-flange columns with strong-axis directly welded flange and flange plated moment connections. Table B-1 is for columns with $F_y = 50$ ksi. For high-seismic applications, see AISC (1997a). All values are given to three significant figures.

For wide-flange columns with extended end-plate moment connections, the design strength equations given in Chapter 2 differ. For a compressive flange force, the designer can either calculate the design strength from the Equations in Chapter 2 or conservatively use the tabulated values. However, for a tensile flange force, the local flange bending limit state is significantly more conservative for extended end-plate moment connections and the designer must calculate the design strength from the Equations in Chapter 2.

A flange force is considered to be applied at an intermediate location when it is applied equal to or greater than the distance shown below from the end of the column.

INTERMEDIATE LOCATION CRITERIA

Limit State	Apply when flange force is applied at least:
Local flange bending	$10t_f$ from the column end
Local web yielding	d_c from the column end
Web crippling	$d_c/2$ from the column end
Compression buckling of the web	$d_c/2$ from the column end

Tensile Flange Forces

The tabulated local column strength is determined as the lesser value from the limit states of local flange bending and local web yielding. For a given W-shape, the table is entered under the appropriate values of N and the design strength is determined from the corresponding tension (**T**) column.

For the limit state of local flange bending, the design strength is determined from LRFD Specification Equation

K1-1, where

$$\phi R_n = 0.90 \times 6.25t_f^2 F_y$$

For the limit state of local web yielding, the design strength is determined from LRFD Specification Equation K1-2, where

$$\phi R_n = 1.0 \times (5k + N) F_y t_w$$

The design strength at intermediate values of N can be determined by linear interpolation.²⁶ In the above discussion and equations,

- t_f = column flange thickness, in.
- d_c = column depth, in.
- N = thickness of beam flange or flange plate that delivers the concentrated force, in.
- F_y = column specified minimum yield strength, ksi
- k = distance from outer face of flange to web toe of flange-to-web fillet, in.
- t_w = column web thickness, in.

Compressive Flange Forces

The tabulated local column strength is determined as the lesser value from the limit states of local web yielding and web crippling. For a given W-shape, the table is entered under the appropriate value of N and the design strength is determined from the corresponding compression (**C**) column. When designing for two opposing compressive flange forces, the local column strength is determined as the lesser value from the limit states of local web yielding, web crippling, and compression buckling of the web. For a given W-shape, the table is entered under the appropriate value of N and the design strength is determined for local web yielding and web crippling from the corresponding compression (**C**) column. The lesser of this value and that tabulated for compression buckling of the web is taken as the design strength.

For the limit state of local web yielding, the design strength is determined from LRFD Specification Equation

²⁵An intermediate column location is one that is far enough from the column end that the reductions for column-end locations in AISC LRFD Specification Section K1 do not apply. See the discussion in Appendix C for Table C-1 for further information.

²⁶Note that the value determined by linear interpolation between tabulated values will be approximate, since the equations used to generate the tabulated values are not necessarily linear.

K1-2, where

$$\phi R_n = 1.0 \times (5k + N)F_y t_w$$

For the limit state of web crippling, the design strength is determined from LRFD Specification Equation K1-4, where

$$\phi R_n = 0.75 \times 135t_w^2 \left[1 + 3 \left(\frac{N}{d_c} \right) \left(\frac{t_w}{t_f} \right)^{1.5} \right] \sqrt{\frac{F_y t_f}{t_w}}$$

For the limit state of compression buckling of the web, the design strength is determined from LRFD Specification Equation K1-8, where

$$\phi R_n = 0.90 \times \frac{4,100t_w^3 \sqrt{F_y}}{h}$$

The design strength at intermediate values of N can be determined by linear interpolation.²⁷ In the above discussion and equations,

N = thickness of beam flange or flange plate that delivers the concentrated force, in.

F_y = column specified minimum yield strength, ksi

k = distance from outer face of column flange to web toe of flange-to-web fillet, in.

t_w = column web thickness, in.

t_f = column flange thickness, in.

d_c = column depth, in.

h = $d_c - 2k$, in.

²⁷Note that the value determined by linear interpolation between tabulated values will be approximate, since the equations used to generate the tabulated values are not necessarily linear.

Table B-1
Local Column Strength at Intermediate Location Along Wide-Flange Column, $F_y = 50$ ksi
(Wind and Low-Seismic Applications, see Section 1.4)

Shape	Least Design Strength for Local Flange Bending, Local Web Yielding, and Web Crippling ϕR_n , kips																Web Compr. Buckling ϕR_n , kips
	N, in.																
	1/4		1/2		3/4		1		1 1/4		1 1/2		1 3/4		2		
	T	C	T	C	T	C	T	C	T	C	T	C	T	C	T	C	
W44 ×335	666	666	679	679	692	692	704	704	717	717	730	730	743	743	755	755	712
×290	527	527	538	538	549	549	560	560	571	571	582	582	593	593	604	604	442
×262	442	442	452	452	462	462	472	472	481	481	491	491	501	501	511	511	330
×230	364	364	373	373	382	382	391	391	399	399	408	408	417	417	419	426	240
W40 ×593	2010	2010	2030	2030	2050	2050	2080	2080	2100	2100	2120	2120	2140	2140	2170	2170	4390
×503	1540	1540	1550	1550	1574	1574	1593	1593	1612	1612	1631	1631	1651	1651	1670	1670	2790
×431	1210	1210	1230	1230	1240	1240	1260	1260	1280	1280	1290	1290	1310	1310	1330	1330	1840
×372	957	957	972	972	986	986	1000	1000	1020	1020	1030	1030	1040	1040	1060	1060	1190
×321	747	747	759	759	772	772	784	784	797	797	809	809	822	822	834	834	763
×297	724	724	735	735	747	747	759	759	766	770	766	782	766	793	766	805	622
×277	581	581	591	591	602	602	612	612	623	623	633	633	643	643	654	654	436
×249	502	502	511	511	520	520	530	530	539	539	548	548	558	558	567	567	323
×215	394	394	402	402	410	410	418	418	419	427	419	433	419	436	419	439	209
×199	319	319	319	319	322	319	322	319	322	319	322	319	322	319	322	319	210
×174	194	333	194	341	194	349	194	358	194	365	194	370	194	374	194	379	210
W40 ×466	1740	1740	1760	1760	1790	1790	1810	1810	1830	1830	1850	1850	1870	1870	1890	1890	3550
×392	1330	1330	1350	1350	1360	1360	1380	1380	1400	1400	1420	1420	1430	1430	1450	1450	2190
×331	1030	1030	1040	1040	1060	1060	1070	1070	1090	1090	1100	1100	1120	1120	1130	1130	1390
×278	778	778	791	791	803	803	816	816	829	829	842	842	854	854	867	867	811
×264	717	717	729	729	741	741	753	753	765	765	777	777	789	789	801	801	676
×235	581	581	591	591	602	602	612	612	623	623	633	633	643	643	654	654	436
×211	502	502	511	511	520	520	530	530	539	539	548	548	558	558	567	567	323
×183	394	394	402	402	410	410	418	418	419	427	419	433	419	436	419	439	209
×167	295	364	295	372	295	380	295	388	295	396	295	402	295	406	295	410	209
×149	194	323	194	331	194	339	194	343	194	347	194	352	194	356	194	360	191
W36 ×848	3620	3620	3650	3650	3680	3680	3710	3710	3740	3740	3770	3770	3800	3800	3840	3840	13400
×798	3270	3270	3300	3300	3330	3330	3350	3350	3380	3380	3410	3410	3440	3440	3470	3470	11300
×650	2330	2330	2360	2360	2380	2380	2410	2410	2430	2430	2460	2460	2480	2480	2510	2510	6420
×527	1660	1660	1680	1680	1700	1700	1720	1720	1740	1740	1760	1760	1780	1780	1800	1800	3500
×439	1230	1230	1250	1250	1260	1260	1280	1280	1300	1300	1310	1310	1330	1330	1350	1350	2110
×393	1030	1030	1040	1040	1060	1060	1070	1070	1090	1090	1100	1100	1120	1120	1130	1130	1520
×359	889	889	903	903	917	917	931	931	945	945	959	959	973	973	987	987	1180
×328	778	778	791	791	803	803	816	816	829	829	842	842	854	854	867	867	891
×300	676	676	688	688	700	700	712	712	724	724	735	735	747	747	759	759	708
×280	606	606	617	617	628	628	639	639	650	650	661	661	672	672	683	683	581
×260	549	549	559	559	570	570	580	580	583	591	583	601	583	612	583	622	497
×245	510	510	513	520	513	530	513	540	513	550	513	560	513	570	513	580	430
×230	447	461	447	470	447	480	447	489	447	499	447	508	447	518	447	527	368
W36 ×256	642	642	654	654	666	666	678	678	690	690	702	702	714	714	726	726	717
×232	555	555	566	566	576	576	587	587	598	598	609	609	620	620	631	631	535
×210	490	490	501	501	511	511	520	521	520	532	520	542	520	552	520	563	465
×194	428	428	437	437	447	447	447	457	447	466	447	476	447	485	447	495	364
×182	392	394	392	403	392	412	392	421	392	430	392	440	392	449	392	458	310
×170	340	349	340	357	340	366	340	374	340	383	340	391	340	400	340	408	255
×160	293	323	293	331	293	339	293	347	293	355	293	364	293	372	293	380	223
×150	249	301	249	309	249	316	249	324	249	332	249	340	249	348	249	355	198
×135	176	261	176	268	176	276	176	283	176	291	176	298	176	306	176	313	175

Table B-1 (cont'd)
Local Column Strength at Intermediate Location Along Wide-Flange Column, $F_y = 50$ ksi
(Wind and Low-Seismic Applications, see Section 1.4)

Shape	Least Design Strength for Local Flange Bending, Local Web Yielding, and Web Crippling ϕR_n , kips																Web Compr. Buckling ϕR_n , kips
	N, in.																
	1/4		1/2		3/4		1		1 1/4		1 1/2		1 3/4		2		
	T	C	T	C	T	C	T	C	T	C	T	C	T	C	T	C	
W33 ×354	848	848	863	863	877	877	892	892	906	906	921	921	935	935	950	950	1370
×318	712	712	725	725	738	738	751	751	764	764	777	777	790	790	803	803	985
×291	627	627	639	639	651	651	663	663	675	675	687	687	699	699	711	711	777
×263	527	527	538	538	549	549	560	560	571	571	582	582	593	593	604	604	577
×241	464	464	475	475	485	485	495	495	506	506	516	516	527	527	537	537	501
×221	409	409	419	419	429	429	438	438	448	448	457	457	467	467	477	477	407
×201	355	355	364	364	372	372	382	382	391	391	372	400	372	409	372	418	320
W33 ×169	354	354	362	362	371	371	379	379	387	387	396	396	404	404	412	412	264
×152	306	306	313	314	313	321	313	329	313	337	313	345	313	353	313	361	225
×141	259	272	259	280	259	287	259	295	259	303	259	310	259	318	259	325	194
×130	206	252	206	259	206	266	206	274	206	281	206	288	206	295	206	303	171
×118	154	222	154	229	154	235	154	242	154	249	154	256	154	263	154	270	146
W30 ×477	1550	1550	1570	1570	1590	1590	1610	1610	1630	1630	1650	1650	1670	1670	1690	1690	4230
×391	1120	1120	1140	1140	1160	1160	1170	1170	1190	1190	1210	1210	1220	1220	1240	1240	2460
×326	816	816	830	830	844	844	859	859	873	873	887	887	901	901	916	916	1440
×292	682	682	695	695	708	708	720	720	733	733	746	746	759	759	771	771	1030
×261	578	578	590	590	602	602	613	613	625	625	636	636	648	648	660	660	785
×235	477	477	488	488	498	498	508	508	519	519	529	529	540	540	550	550	557
×211	421	421	431	431	441	441	450	450	460	460	470	470	480	480	486	489	455
×191	353	353	362	362	371	371	379	379	388	388	395	397	395	406	395	415	348
×173	315	315	319	323	319	332	319	340	319	348	319	356	319	364	319	373	275
W30 ×148	333	333	341	341	349	349	358	358	366	366	374	374	382	382	390	390	269
×132	277	277	281	284	281	292	281	300	281	308	281	315	281	323	281	331	226
×124	243	254	243	261	243	269	243	276	243	283	243	291	243	298	243	305	195
×116	203	237	203	244	203	251	203	258	203	265	203	272	203	279	203	286	176
×108	162	220	162	227	162	233	162	240	162	247	162	254	162	261	162	267	158
×99	126	193	126	200	126	206	126	213	126	219	126	226	126	232	126	239	137
×90	105	160	105	166	105	172	105	178	105	184	105	189	105	195	105	201	101
W27 ×539	2120	2120	2140	2140	2170	2170	2190	2190	2220	2220	2240	2240	2270	2270	2290	2290	8310
×448	1540	1540	1560	1560	1580	1580	1600	1600	1620	1620	1650	1650	1670	1670	1690	1690	4880
×368	1120	1120	1130	1130	1150	1150	1170	1170	1190	1190	1200	1200	1220	1220	1240	1240	2860
×307	830	830	845	845	859	859	874	874	888	888	903	903	917	917	932	932	1700
×258	625	625	637	637	649	649	662	662	674	674	686	686	698	698	711	711	1020
×235	537	537	549	549	560	560	572	572	583	583	594	594	606	606	617	617	818
×217	464	464	475	475	485	485	495	495	506	506	516	516	527	527	537	537	620
×194	396	396	405	405	415	415	424	424	434	434	443	443	452	452	462	462	459
×178	349	349	358	358	367	367	376	376	385	385	394	394	398	403	398	412	413
×161	307	307	316	316	324	324	328	332	328	340	328	349	328	357	328	365	313
×146	263	263	267	270	267	278	267	285	267	293	267	301	267	308	267	316	241
W27 ×129	284	284	292	292	299	299	307	307	315	315	322	322	330	330	337	337	247
×114	239	239	243	246	243	253	243	260	243	267	243	274	243	281	243	289	201
×102	194	208	194	214	194	220	194	227	194	233	194	240	194	246	194	253	149
×94	156	182	156	188	156	194	156	201	156	207	156	213	156	219	156	225	128
×84	115	164	115	170	115	175	115	181	115	187	115	193	115	198	115	203	106

Table B-1 (cont'd)
Local Column Strength at Intermediate Location Along Wide-Flange Column, $F_y = 50$ ksi
(Wind and Low-Seismic Applications, see Section 1.4)

Shape	Least Design Strength for Local Flange Bending, Local Web Yielding, and Web Crippling ϕR_n , kips																Web Compr. Buckling ϕR_n , kips
	N, in.																
	1/4		1/2		3/4		1		1 1/4		1 1/2		1 3/4		2		
	T	C	T	C	T	C	T	C	T	C	T	C	T	C	T	C	
W24 ×492	2150	2150	2170	2170	2200	2200	2220	2220	2250	2250	2270	2270	2300	2300	2320	2320	9490
×408	1570	1570	1590	1590	1610	1610	1630	1630	1650	1650	1670	1670	1690	1690	1710	1710	5570
×335	1140	1140	1160	1160	1170	1170	1190	1190	1210	1210	1230	1230	1240	1240	1260	1260	3260
×279	848	848	863	863	877	877	892	892	906	906	921	921	935	935	950	950	1940
×250	712	712	725	725	738	738	751	751	764	764	777	777	790	790	803	803	1400
×229	612	612	624	624	636	636	648	648	660	660	672	672	684	684	696	696	1100
×207	527	527	538	538	549	549	560	560	571	571	582	582	593	593	604	604	820
×192	466	466	476	476	486	486	496	496	506	506	516	516	527	527	537	537	661
×176	408	408	417	417	427	427	436	436	445	445	455	455	464	464	473	473	524
×162	361	361	370	370	379	379	388	388	397	397	405	405	414	414	419	423	435
×146	313	313	321	321	329	329	334	337	334	345	334	353	334	362	334	370	341
×131	259	272	259	280	259	287	259	295	259	303	259	310	259	318	259	325	275
×117	203	230	203	237	203	244	203	251	203	258	203	265	203	272	203	278	207
×104	158	194	158	200	158	206	158	213	158	219	158	225	158	231	158	238	155
W24 ×103	248	248	254	254	261	261	268	268	270	275	270	282	270	289	270	296	206
×94	215	216	215	222	215	229	215	235	215	241	215	248	215	254	215	261	169
×84	167	189	167	195	167	201	167	207	167	213	167	219	167	223	167	226	129
×76	130	164	130	169	130	175	130	180	130	186	130	189	130	192	130	195	106
×68	96.3	148	96.3	152	96.3	155	96.3	157	96.3	160	96.3	163	96.3	166	96.3	169	88.9
W24 ×62	97.9	153	97.9	159	97.9	164	97.9	167	97.9	170	97.9	173	97.9	176	97.9	179	98.8
×55	71.7	129	71.7	132	71.7	135	71.7	137	71.7	140	71.7	143	71.7	146	71.7	149	76.8
W21 ×201	552	552	563	563	574	574	586	586	597	597	609	609	620	620	631	631	1080
×182	477	477	488	488	498	498	508	508	519	519	529	529	540	540	550	550	819
×166	408	408	417	417	427	427	436	436	445	445	455	455	464	464	473	473	604
×147	347	347	356	356	365	365	372	374	372	383	372	392	372	401	372	410	532
×132	301	303	301	311	301	319	301	327	301	335	301	343	301	351	301	360	394
×122	259	261	259	268	259	276	259	283	259	291	259	298	259	306	259	313	308
×111	215	230	215	237	215	244	215	251	215	258	215	265	215	272	215	278	238
×101	180	202	180	208	180	214	180	220	180	227	180	233	180	239	180	245	179
W21 ×93	243	252	243	259	243	266	243	274	243	281	243	288	243	295	243	303	279
×83	196	208	196	214	196	220	196	227	196	233	196	240	196	246	196	253	195
×73	154	176	154	182	154	188	154	193	154	199	154	205	154	210	154	215	135
×68	132	160	132	165	132	171	132	176	132	181	132	185	132	188	132	191	114
×62	106	143	106	147	106	150	106	153	106	155	106	158	106	161	106	163	91.6
W21 ×57	119	144	119	149	119	154	119	159	119	162	119	164	119	167	119	170	94.7
×50	80.5	125	80.5	128	80.5	131	80.5	133	80.5	136	80.5	139	80.5	141	80.5	144	78.6
×44	57.0	102	57.0	104	57.0	107	57.0	109	57.0	112	57.0	114	57.0	117	57.0	119	61.2
W18 ×311	1330	1330	1340	1340	1360	1360	1380	1380	1400	1400	1420	1420	1440	1440	1460	1460	5930
×283	1130	1130	1150	1150	1170	1170	1190	1190	1200	1200	1220	1220	1240	1240	1260	1260	4630
×258	976	976	992	992	1010	1010	1020	1020	1040	1040	1060	1060	1070	1070	1090	1090	3540
×234	812	812	827	827	841	841	856	856	870	870	885	885	899	899	914	914	2620
×211	692	692	706	706	719	719	732	732	745	745	759	759	772	772	785	785	2000
×192	597	597	609	609	621	621	633	633	645	645	657	657	669	669	681	681	1490
×175	512	512	523	523	534	534	545	545	556	556	567	567	579	579	590	590	1180
×158	440	440	451	451	461	461	471	471	481	481	491	491	501	501	511	511	896
×143	374	374	383	383	392	392	402	402	411	411	420	420	429	429	438	438	655
×130	322	322	331	331	339	339	348	348	356	356	364	364	373	373	381	381	506

Table B-1 (cont'd)
Local Column Strength at Intermediate Location Along Wide-Flange Column, $F_y = 50$ ksi
(Wind and Low-Seismic Applications, see Section 1.4)

Shape	Least Design Strength for Local Flange Bending, Local Web Yielding, and Web Crippling ϕR_n , kips																Web Compr. Buckling ϕR_n , kips
	N, in.																
	1/4		1/2		3/4		1		1 1/4		1 1/2		1 3/4		2		
	T	C	T	C	T	C	T	C	T	C	T	C	T	C	T	C	
W18×119	295	295	303	303	311	311	316	319	316	328	316	336	316	344	316	352	474
×106	247	247	249	254	249	262	249	269	249	277	249	284	249	291	249	299	346
×97	213	216	213	222	213	229	213	236	213	242	213	249	213	256	213	262	258
×86	167	179	167	185	167	191	167	197	167	203	167	209	167	215	167	221	186
×76	130	151	130	157	130	162	130	167	130	173	130	178	130	183	130	189	130
W18×71	185	192	185	198	185	204	185	210	185	217	185	223	185	229	185	235	205
×65	158	167	158	173	158	179	158	184	158	190	158	195	158	201	158	207	154
×60	136	148	136	153	136	158	136	163	136	169	136	174	136	179	136	184	120
×55	112	133	112	138	112	143	112	147	112	152	112	155	112	158	112	161	100
×50	91.4	115	91.4	119	91.4	121	91.4	124	91.4	126	91.4	128	91.4	131	91.4	133	75.4
W18×46	103	117	103	122	103	126	103	129	103	132	103	134	103	136	103	139	78.2
×40	77.5	93.5	77.5	95.3	77.5	97.1	77.5	98.9	77.5	101	77.5	102	77.5	104	77.5	106	52.5
×35	50.8	78.6	50.8	80.5	50.8	82.5	50.8	84.4	50.8	86.3	50.8	88.3	50.8	90.2	50.8	92.1	45.6
W16×100	254	254	261	261	269	269	273	276	273	283	273	291	273	298	273	305	384
×89	212	212	215	218	215	225	215	231	215	238	215	244	215	251	215	258	277
×77	162	169	162	175	162	181	162	186	162	192	162	198	162	203	162	209	180
×67	124	141	124	146	124	151	124	156	124	160	124	163	124	166	124	169	118
W16×57	144	153	144	159	144	164	144	169	144	175	144	180	144	185	144	191	152
×50	112	129	112	134	112	139	112	144	112	147	112	150	112	153	112	156	105
×45	89.8	111	89.8	114	89.8	116	89.8	119	89.8	121	89.8	124	89.8	126	89.8	128	78.6
×40	71.7	87.6	71.7	89.5	71.7	91.4	71.7	93.2	71.7	95.1	71.7	97.0	71.7	99	71.7	101	54.3
×36	52.0	77.2	52.0	79.3	52.0	81.3	52.0	83.3	52.0	85.3	52.0	87.4	52.0	89.4	52.0	91.4	49.2
W16×31	54.5	70.1	54.5	71.7	54.5	73.3	54.5	74.9	54.5	76.5	54.5	78.1	54.5	79.7	54.5	81.3	39.8
×26	33.5	54.1	33.5	55.7	33.5	57.2	33.5	58.8	33.5	60.3	33.5	61.9	33.5	63.4	33.5	65.0	30.1
W14×808	5480	5480	5530	5530	5580	5580	5620	5620	5670	5670	5720	5720	5760	5760	5810	5810	122000
×730	4310	4310	4350	4350	4380	4380	4420	4420	4460	4460	4500	4500	4540	4540	4580	4580	66800
×665	3710	3710	3740	3740	3780	3780	3810	3810	3850	3850	3880	3880	3920	3920	3950	3950	52500
×605	3160	3160	3190	3190	3220	3220	3250	3250	3280	3280	3320	3320	3350	3350	3380	3380	40400
×550	2710	2710	2740	2740	2770	2770	2800	2800	2830	2830	2860	2860	2890	2890	2920	2920	31300
×500	2320	2320	2350	2350	2380	2380	2400	2400	2430	2430	2460	2460	2480	2480	2510	2510	24400
×455	1980	1980	2000	2000	2030	2030	2050	2050	2080	2080	2100	2100	2130	2130	2150	2150	18900
W14×426	1750	1750	1780	1780	1800	1800	1820	1820	1850	1850	1870	1870	1890	1890	1920	1920	15200
×398	1570	1570	1590	1590	1620	1620	1640	1640	1660	1660	1680	1680	1700	1700	1730	1730	12800
×370	1390	1390	1410	1410	1430	1430	1450	1450	1470	1470	1500	1500	1520	1520	1540	1540	10500
×342	1220	1220	1240	1240	1260	1260	1280	1280	1300	1300	1320	1320	1340	1340	1360	1360	8440
×311	1050	1050	1070	1070	1090	1090	1110	1110	1120	1120	1140	1140	1160	1160	1180	1180	6500
×283	903	903	919	919	935	935	951	951	968	968	984	984	1000	1000	1020	1020	4980
×257	767	767	782	782	797	797	811	811	826	826	841	841	856	856	870	870	3760
×233	649	649	662	662	675	675	689	689	702	702	716	716	729	729	742	742	2830
×211	564	564	576	576	588	588	600	600	613	613	625	625	637	637	649	649	2190
×193	484	484	495	495	506	506	517	517	528	528	540	540	551	551	562	562	1640
×176	425	425	436	436	446	446	457	457	467	467	477	477	483	483	483	483	1330
×159	359	359	368	368	377	377	386	386	396	396	398	398	405	405	398	424	961
×145	306	306	315	315	323	323	332	332	334	334	340	340	349	349	334	366	727

Table B-1 (cont'd)
Local Column Strength at Intermediate Location Along Wide-Flange Column, $F_y = 50$ ksi
(Wind and Low-Seismic Applications, see Section 1.4)

Shape	Least Design Strength for Local Flange Bending, Local Web Yielding, and Web Crippling ϕR_n , kips																Web Compr. Buckling ϕR_n , kips
	N, in.																
	$\frac{1}{4}$		$\frac{1}{2}$		$\frac{3}{4}$		1		$1\frac{1}{4}$		$1\frac{1}{2}$		$1\frac{3}{4}$		2		
	T	C	T	C	T	C	T	C	T	C	T	C	T	C	T	C	
W14 ×132 ×120 ×109 ×99 ×90	280	280	288	288	296	296	298	304	298	312	298	320	298	329	298	337	620
	247	247	249	254	249	262	249	269	249	277	249	284	249	291	249	299	477
	208	212	208	218	208	225	208	231	208	238	208	244	208	251	208	258	337
	171	180	171	186	171	192	171	199	171	205	171	211	171	217	171	223	264
	142	157	142	162	142	168	142	173	142	179	142	184	142	190	142	195	197
W14 ×82 ×74 ×68 ×61	206	214	206	220	206	226	206	233	206	239	206	245	206	252	206	258	313
	173	181	173	187	173	193	173	198	173	204	173	210	173	215	173	221	215
	146	161	146	166	146	171	146	176	146	181	146	185	146	189	146	193	169
	117	135	117	138	117	142	117	145	117	148	117	151	117	154	117	157	125
W14 ×53 ×48 ×43	123	134	123	137	123	140	123	143	123	146	123	149	123	152	123	155	120
	100	112	99.6	115	100	117	99.6	120	100	122	99.6	125	100	127	99.6	130	92.9
	79.0	89.9	79.0	92.0	79.0	94.1	79.0	96.2	79.0	98	79.0	100	79.0	103	79.0	105	67.1
W14 ×38 ×34 ×30	74.6	86.2	74.6	90.1	74.6	94.0	74.6	97.5	74.6	100	74.6	102	74.6	104	74.6	106	64.9
	58.2	74.8	58.2	77.4	58.2	79.3	58.2	81.3	58.2	83.2	58.2	85.2	58.2	87.2	58.2	89.1	50.4
	41.7	64.3	41.7	66.3	41.7	68.3	41.7	70.3	41.7	72.2	41.7	74.2	41.7	76.2	41.7	78.2	42.9
W14 ×26 ×22	49.6	61.3	49.6	62.8	49.6	64.3	49.6	65.8	49.6	67.4	49.6	68.9	49.6	70.4	49.6	71.9	35.9
	31.6	47.1	31.6	48.5	31.6	50.0	31.6	51.4	31.6	52.8	31.6	54.2	31.6	55.6	31.6	57.1	26.5
W12 ×336 ×305 ×279 ×252 ×230 ×210 ×190 ×170 ×152 ×136 ×120 ×106 ×96 ×87 ×79 ×72 ×65	1660	1660	1680	1680	1700	1700	1730	1730	1750	1750	1770	1770	1790	1790	1810	1810	15500
	1420	1420	1440	1440	1460	1460	1480	1480	1500	1500	1520	1520	1540	1540	1560	1560	11900
	1240	1240	1260	1260	1280	1280	1300	1300	1320	1320	1330	1330	1350	1350	1370	1370	9860
	1040	1040	1060	1060	1080	1080	1090	1090	1110	1110	1130	1130	1150	1150	1160	1160	7430
	900	900	916	916	932	932	948	948	964	964	980	980	996	996	1010	1010	5800
	789	789	804	804	819	819	833	833	848	848	863	863	878	878	892	892	4530
	659	659	672	672	686	686	699	699	712	712	725	725	739	739	752	752	3270
	552	552	564	564	576	576	588	588	600	600	612	612	624	624	636	636	2420
	473	473	484	484	495	495	506	506	517	517	527	527	538	538	549	549	1820
	393	393	402	402	412	412	422	422	432	432	439	442	439	452	439	462	1350
	331	331	339	339	343	348	343	357	343	366	343	375	343	384	343	393	984
	265	265	273	273	276	280	276	288	276	295	276	303	276	311	276	318	622
	228	230	228	237	228	244	228	251	228	258	228	265	228	272	228	278	459
	185	200	185	206	185	212	185	219	185	225	185	232	185	238	185	245	374
	152	175	152	181	152	187	152	192	152	198	152	204	152	210	152	216	285
126	153	126	159	126	164	126	169	126	175	126	180	126	185	126	191	218	
103	133	103	138	103	143	103	147	103	152	103	157	103	162	103	167	163	
W12 ×58 ×53	115	127	115	130	115	133	115	137	115	140	115	143	115	146	115	149	129
	93.0	112	93.0	116	93.0	120	93.0	123	93.0	126	93.0	129.1	93.0	132	93.0	135	112
W12 ×50 ×45 ×40	115	132	115	136	115	139	115	143	115	146	115	150	115	153	115	157	140
	93.0	108	93.0	111	93.0	114	93.0	117	93.0	120	93.0	123	93.0	126	93.0	129	103
	74.6	84.6	74.6	86.8	74.6	89.0	74.6	91.3	74.6	93.5	74.6	95.8	74.6	98	74.6	100	71.0
W12 ×35 ×30 ×26	76.1	78.8	76.1	82.5	76.1	86.3	76.1	90.0	76.1	93.8	76.1	97.5	76.1	100	76.1	103	67.1
	54.5	64.2	54.5	66.4	54.5	68.2	54.5	69.9	54.5	71.7	54.5	73.4	54.5	75.1	54.5	76.9	43.8
	40.6	50.1	40.6	51.5	40.6	52.9	40.6	54.3	40.6	55.7	40.6	57.1	40.6	58.5	40.6	59.9	30.3

Table B-1 (cont'd)
Local Column Strength at Intermediate Location Along Wide-Flange Column, $F_y = 50$ ksi
(Wind and Low-Seismic Applications, see Section 1.4)

Shape	Least Design Strength for Local Flange Bending, Local Web Yielding, and Web Crippling ϕR_n , kips																Web Compr. Buckling ϕR_n , kips
	N, in.																
	$\frac{1}{4}$		$\frac{1}{2}$		$\frac{3}{4}$		1		$1\frac{1}{4}$		$1\frac{1}{2}$		$1\frac{3}{4}$		2		
	T	C	T	C	T	C	T	C	T	C	T	C	T	C	T	C	
W12 ×22	50.8	60.1	50.8	63.4	50.8	66.6	50.8	69.1	50.8	70.9	50.8	72.7	50.8	74.5	50.8	76.3	43.4
×19	34.5	49.9	34.5	51.5	34.5	53.2	34.5	54.8	34.5	56.4	34.5	58.1	34.5	59.7	34.5	61.4	32.1
×16	19.8	39.8	19.8	41.6	19.8	43.4	19.8	45.2	19.8	47.0	19.8	48.8	19.8	50.6	19.8	52.4	26.5
×14	14.2	32.0	14.2	33.6	14.2	35.2	14.2	36.8	14.2	38.4	14.2	40.0	14.2	41.6	14.2	43.2	19.8
W10 ×112	363	363	373	373	382	382	392	392	401	401	411	411	420	420	429	429	1476
×100	306	306	315	315	323	323	332	332	340	340	349	349	353	357	353	366	1080
×88	253	253	261	261	268	268	276	276	276	284	276	291	276	299	276	306	761
×77	205	205	212	212	213	219	213	225	213	232	213	239	213	245	213	252	511
×68	167	167	167	173	167	179	167	185	167	191	167	197	167	203	167	209	354
×60	130	143	130	148	130	154	130	159	130	164	130	169	130	175	130	180	255
×54	106	120	106	125	106	130	106	134	106	139	106	143	106	148	106	153	174
×49	88.2	105	88.2	109	88.2	114	88.2	118	88.2	122	88.2	126	88.2	131	88.2	135	135
W10 ×45	108	114	108	118	108	123	108	127	108	131	108	136	108	140	108	144	147
×39	79.0	92.5	79.0	96.5	79.0	100	79.0	104	79.0	108	79.0	111	79.0	114	79.0	118	106
×33	53.2	76.8	53.2	79.9	53.2	83.0	53.2	86.1	53.2	89.2	53.2	92.3	53.2	95.4	53.2	98.5	83.7
W10 ×30	73.2	74.1	73.2	77.8	73.2	81.6	73.2	85.3	73.2	89.1	73.2	92.8	73.2	96.6	73.2	100	82.0
×26	54.5	60.1	54.5	63.4	54.5	66.6	54.5	69.9	54.5	73.1	54.5	75.4	54.5	77.5	54.5	79.6	53.4
×22	36.5	48.0	36.5	51.0	36.5	54.0	36.5	57.0	36.5	60.0	36.5	62.7	36.5	64.7	36.5	66.7	41.6
W10 ×19	43.9	53.9	43.9	57.0	43.9	60.2	43.9	63.3	43.9	66.4	43.9	68.7	43.9	70.8	43.9	72.8	47.3
×17	30.6	48.0	30.6	51.0	30.6	54.0	30.6	57.0	30.6	59.5	30.6	61.7	30.6	63.9	30.6	66.2	41.9
×15	20.5	42.4	20.5	45.3	20.5	48.2	20.5	50.7	20.5	53.1	20.5	55.6	20.5	58.0	20.5	60.4	36.9
×12	12.4	28.9	12.4	30.7	12.4	32.5	12.4	34.3	12.4	36.1	12.4	37.8	12.4	39.6	12.4	41.4	20.8
W8 ×67	212	212	219	219	226	226	233	233	240	240	246	248	246	255	246	262	789
×58	174	174	180	180	185	186	185	193	185	199	185	206	185	212	185	218	565
×48	124	124	129	129	132	134	132	139	132	144	132	149	132	154	132	159	273
×40	88.2	100	88.2	105	88.2	109	88.2	114	88.2	118	88.2	123	88.2	127	88.2	132	199
×35	68.9	81.4	68.9	85.3	68.9	89.1	68.9	93.0	68.9	96.9	68.9	101	68.9	105	68.9	109	127
×31	53.2	70.4	53.2	73.9	53.2	77.5	53.2	81.0	53.2	84.6	53.2	88.2	53.2	91.7	53.2	95.3	98.6
W8 ×28	60.8	70.4	60.8	73.9	60.8	77.5	60.8	81.0	60.8	84.6	60.8	88.2	60.8	91.7	60.8	95.3	97.7
×24	45.0	56.7	45.0	59.7	45.0	62.4	45.0	64.9	45.0	67.4	45.0	69.8	45.0	72.3	45.0	74.8	62.1
W8 ×21	45.0	53.9	45.0	57.0	45.0	60.2	45.0	63.3	45.0	66.4	45.0	69.5	45.0	72.7	45.0	75.8	61.3
×18	30.6	46.0	30.6	48.9	30.6	51.8	30.6	54.6	30.6	57.5	30.6	60.0	30.6	62.4	30.6	64.8	47.8
W8 ×15	27.9	49.0	27.9	52.1	27.9	55.1	27.9	58.2	27.9	61.3	27.9	64.3	27.9	67.4	27.9	70.4	58.1
×13	18.3	42.4	18.3	45.3	18.3	48.2	18.3	51.0	18.3	53.9	18.3	56.8	18.3	59.7	18.3	62.5	48.0
×10	11.8	24.4	11.8	26.0	11.8	27.6	11.8	29.2	11.8	30.9	11.8	32.5	11.8	34.1	11.8	35.8	19.3
W6 ×25	58.2	69.0	58.2	73.0	58.2	77.0	58.2	81.0	58.2	85.0	58.2	89.0	58.2	93.0	58.2	97.0	180
×20	37.5	52.0	37.5	55.3	37.5	58.5	37.5	61.8	37.5	65.0	37.5	68.3	37.5	71.5	37.5	74.8	98
×15	19.0	38.8	19.0	41.7	19.0	44.6	19.0	47.4	19.0	50.3	19.0	53.2	19.0	56.1	19.0	58.9	67
W6 ×16	46.1	52.0	46.1	55.3	46.1	58.5	46.1	61.8	46.1	65.0	46.1	68.3	46.1	71.5	46.1	74.8	96
×12	22.1	38.8	22.1	41.7	22.1	44.6	22.1	47.4	22.1	50.3	22.1	53.2	22.1	56.1	22.1	58.9	66
×9	13.0	25.3	13.0	27.4	13.0	29.5	13.0	31.6	13.0	33.7	13.0	35.7	13.0	37.8	13.0	39.9	26.8
W5 ×19	52.0	58.2	52.0	61.6	52.0	65.0	52.0	68.3	52.0	71.7	52.0	75.1	52.0	78.5	52.0	81.8	146
×16	36.5	48.0	36.5	51.0	36.5	54.0	36.5	57.0	36.5	60.0	36.5	63.0	36.5	66.0	36.5	69.0	103
W4 ×13	33.5	51.6	33.5	55.1	33.5	58.6	33.5	62.1	33.5	65.6	33.5	69.1	33.5	72.6	33.5	76.1	206

Appendix C

LOCAL COLUMN STRENGTH AT A WIDE-FLANGE COLUMN-END LOCATION

For wind and low-seismic applications, Table C-1 aids in the determination of the local column strength at column-end locations for wide-flange columns with strong-axis directly welded flange and flange plated moment connections. Table C-1 is for columns with $F_y = 50$ ksi. For high-seismic applications, see AISC (1997a). All values are given to three significant figures.

For wide-flange columns with extended end-plate moment connections, the design strength equations given in Chapter 2 differ. For a compressive flange force, the designer can either calculate the design strength from the Equations in Chapter 2 or conservatively use the tabulated values. However, for a tensile flange force, the local flange bending limit state is significantly more conservative for extended end-plate moment connections and the designer must calculate the design strength from the Equations in Chapter 2.

A flange force is considered to be applied at a column-end location when it is applied less than the distance shown below from the end of the column.

COLUMN-END CRITERIA

Limit State	Apply when flange force is applied less than:
Local flange bending	$10t_f$ from the column end
Local web yielding	d_c from the column end
Web crippling	$d_c/2$ from the column end
Compression buckling of the web	$d_c/2$ from the column end

The values in Tables C-1 and C-2 are calculated assuming the flange force is applied at a distance from the column end that is less than all four of the foregoing column-end criteria. When the flange force is applied at a distance from the column end that is less than one or more, but not all of the foregoing column-end criteria, the tabulated values will be conservative. The user may find it advantageous to calculate the individual design strengths in lieu of using the tabulated values.

Tensile Flange Forces

The tabulated local column strength is determined as the lesser value from the limit states of local flange bending and local web yielding. For a given W-shape, the table is

entered under the appropriate value of N and the design strength is determined from the corresponding tension (T) column.

For the limit state of local flange bending, the design strength is determined from LRFD Specification Equation K1-1 with a 50-percent reduction, where

$$\phi R_n = 0.90 \times \frac{6.25t_f^2 F_y}{2}$$

For the limit state of local web yielding, the design strength is determined from LRFD Specification Equation K1-3, where

$$\phi R_n = 1.0 \times (2.5k + N)F_y t_w$$

The design strength at intermediate values of N can be determined by linear interpolation.²⁸ In the above discussion and equations,

t_f = column flange thickness, in.

d_c = column depth, in.

N = thickness of beam flange or flange plate that delivers the concentrated force, in.

F_y = column specified minimum yield strength, ksi

k = distance from outer face of column flange to web toe of flange-to-web fillet, in.

t_w = column web thickness, in.

Compressive Flange Forces

The tabulated local column strength is determined as the lesser value from the limit states of local web yielding and web crippling. For a given W-shape, the table is entered under the appropriate value of N and the design strength is determined from the corresponding compression (C) column. When designing for two opposing compressive flange forces, the local column strength is determined as the lesser value from the limit states of local web yielding, web crippling, and compression buckling of the web. For a given W-shape, the table is entered under the appropriate value of N and the design strength is determined for local web yielding and web crippling from the corresponding

²⁸Note that the value determined by linear interpolation between tabulated values will be approximate, since the equations used to generate the tabulated values are not necessarily linear.

compression (C) column. The lesser of this value and that tabulated for compression buckling of the web is taken as the design strength.

For the limit state of local web yielding, the design strength is determined from LRFD Specification Equation K1-3, where

$$\phi R_n = 1.0 \times (2.5k + N)F_y t_w$$

For the limit state of web crippling, the design strength is determined from LRFD Specification Equations K1-5a and K1-5b, where if N/d is less than or equal to 0.2:

$$\phi R_n = 0.75 \times 68t_w^2 \left[1 + 3 \left(\frac{N}{d_c} \right) \left(\frac{t_w}{t_f} \right)^{1.5} \right] \sqrt{\frac{F_y t_f}{t_w}}$$

and if N/d is greater than 0.2:

$$\phi R_n = 0.75 \times 68t_w^2 \left[1 + \left(\frac{4N}{d_c} - 0.2 \right) \left(\frac{t_w}{t_f} \right)^{1.5} \right] \sqrt{\frac{F_y t_f}{t_w}}$$

For the limit state of compression buckling of the web, the design strength is determined from LRFD Specification

Equation K1-8 with a 50-percent reduction, where

$$\phi R_n = 0.90 \times \frac{4,100t_w^3 \sqrt{F_y}}{2h}$$

The design strength at intermediate values of N can be determined by linear interpolation.²⁹ In the above discussion and equations,

N = thickness of beam flange or flange plate that delivers the concentrated force, in.

F_y = column specified minimum yield strength, ksi

k = distance from outer face of column flange to web toe of flange-to-web fillet, in.

d_c = column depth, in.

t_w = column web thickness, in.

t_f = column flange thickness, in.²

h = $d_c - 2k$, in.

²⁹Note that the value determined by linear interpolation between tabulated values will be approximate, since the equations used to generate the tabulated values are not necessarily linear.

Shape		Local Column Strength at Wide-Flange Column End Location, $F_y = 50$ ksi (Wind and Low-Seismic Applications, see Section 1.4)																								Web Compr. Buckling ϕR_n , kips
		Least Design Strength for Local Flange Bending, Local Web Yielding, and Web Crippling ϕR_n , kips																								
		N_c in.																								
		1/4		1/2		3/4		1		1 1/4		1 1/2		1 3/4		2		C	C	C	C	C	C	C	C	
T	C	T	C	T	C	T	C	T	C	T	C	T	C	T	C	T	C									T
W44 ×335 ×290 ×262 ×230	339	339	352	365	378	378	390	390	403	403	416	416	429	429	429	429	429	429	429	429	429	429	429	429	356	
	269	269	280	291	302	302	313	313	324	324	334	334	345	345	345	345	345	345	345	345	345	345	345	221		
	226	226	236	246	256	256	265	265	275	275	284	284	284	284	284	284	284	284	284	284	284	284	284	165		
	186	186	195	204	209	213	209	222	222	231	231	231	231	231	231	231	231	231	231	231	231	231	231	120		
W40 ×593 ×503 ×431 ×372 ×321 ×297 ×277 ×249 ×215 ×199 ×174	1020	1020	1040	1060	1080	1080	1110	1110	1130	1130	1150	1150	1170	1170	1170	1170	1170	1170	1170	1170	1170	1170	1170	2190		
	777	777	796	816	835	835	854	854	873	873	893	893	912	912	912	912	912	912	912	912	912	912	912	1390		
	613	613	630	647	664	664	680	680	697	697	714	714	731	731	731	731	731	731	731	731	731	731	731	920		
	486	486	500	515	529	529	544	544	558	558	573	573	587	587	587	587	587	587	587	587	587	587	587	597		
	380	380	392	405	417	417	430	430	441	441	455	455	467	467	467	467	467	467	467	467	467	467	467	381		
	368	368	379	383	391	383	403	403	414	414	426	426	437	437	437	437	437	437	437	437	437	437	437	311		
	296	296	306	316	327	327	337	337	348	348	358	358	369	369	369	369	369	369	369	369	369	369	369	218		
	255	255	265	274	284	284	289	289	291	291	293	293	295	295	295	295	295	295	295	295	295	295	295	161		
	201	201	209	209	213	213	209	215	209	218	218	209	220	209	221	209	221	209	221	209	221	209	221	105		
	160	160	160	160	160	200	160	202	160	206	206	160	208	160	209	208	209	160	208	160	209	160	209	105		
	96.9	96.9	96.9	96.9	96.9	179	96.9	182	96.9	186	186	96.9	189	96.9	191	189	191	96.9	189	96.9	191	96.9	191	105		
	W40 ×466 ×392 ×331 ×278 ×264 ×235 ×211 ×183 ×167 ×149	882	882	903	924	945	945	965	965	986	986	1010	1010	1030	1030	1030	1030	1030	1030	1030	1030	1030	1030	1030	1780	
672		672	690	708	726	726	743	743	761	761	779	779	797	797	797	797	797	797	797	797	797	797	797	1090		
520		520	536	551	566	566	581	581	597	597	612	612	627	627	627	627	627	627	627	627	627	627	627	693		
395		395	408	421	434	434	446	446	459	459	461	461	472	472	472	472	472	472	472	472	472	472	472	405		
365		365	377	389	401	401	413	413	421	421	425	425	437	437	437	437	437	437	437	437	437	437	437	338		
296		296	306	316	327	327	337	337	348	348	358	358	369	369	369	369	369	369	369	369	369	369	369	218		
255		255	265	274	282	282	284	282	289	289	291	291	293	293	293	293	293	293	293	293	293	293	293	161		
201		201	209	209	213	213	209	215	209	218	218	209	220	209	221	209	221	209	221	209	221	209	221	105		
148		148	148	148	148	197	148	199	148	203	203	148	204	148	209	208	209	148	203	148	209	148	209	105		
96.9		96.9	96.9	96.9	96.9	171	96.9	173	96.9	177	177	96.9	180	96.9	181	180	181	96.9	177	96.9	181	96.9	181	95.4		

Table C-1 (cont'd)
Local Column Strength at Wide-Flange Column End Location, $F_y = 50$ ksi
(Wind and Low-Seismic Applications, see Section 1.4)

Shape	Least Design Strength for Local Flange Bending, Local Web Yielding, and Web Crippling ϕR_n , kips																		Web Compr. Buckling ϕR_n , kips	
	N, in.																			
	$1/4$			$1/2$			$3/4$			1		$1 1/4$		$1 1/2$		$1 3/4$		2		
	T	C	T	T	C	T	T	C	T	T	C	T	C	T	C	T	C	T		C
W30 × 477	784	805	825	846	846	866	866	866	866	886	886	886	907	907	907	927	927	927	2120	
× 391	570	587	604	621	621	638	638	638	638	655	655	655	672	672	672	689	689	689	1230	
× 326	415	429	444	458	458	472	472	472	472	486	486	486	501	501	501	515	515	515	722	
× 292	347	360	373	386	386	398	398	398	398	411	411	411	424	424	424	437	437	437	517	
× 261	295	307	318	330	330	341	341	341	341	353	353	353	365	365	365	376	376	376	393	
× 235	244	254	265	275	275	285	285	285	285	296	296	296	306	306	306	316	316	316	278	
× 211	216	225	235	243	243	243	243	243	243	243	243	243	243	243	243	243	243	243	228	
× 191	181	190	197	197	197	197	197	197	197	197	197	197	197	197	197	197	197	197	174	
× 173	160	160	160	160	160	160	160	160	160	160	160	160	160	160	160	160	160	160	137	
W30 × 148	171	179	187	195	195	196	203	203	203	196	196	211	196	196	219	196	196	222	134	
× 132	141	141	141	141	141	141	173	173	173	141	141	181	141	141	188	141	141	191	113	
× 124	122	122	122	122	122	122	145	145	145	122	122	167	122	122	169	122	122	171	97.5	
× 116	102	102	102	102	102	102	136	136	136	102	102	153	102	102	155	102	102	156	87.9	
× 108	81.2	81.2	81.2	81.2	81.2	81.2	127	127	127	81.2	81.2	81.2	81.2	81.2	140	81.2	81.2	142	79.1	
× 99	63.1	63.1	63.1	63.1	63.1	63.1	113	113	113	63.1	63.1	63.1	63.1	63.1	124	63.1	63.1	126	68.5	
× 90	52.3	52.3	52.3	52.3	52.3	52.3	94.7	94.7	94.7	52.3	52.3	98.5	52.3	52.3	102	52.3	52.3	103	50.3	
W27 × 539	1070	1100	1120	1150	1150	1170	1170	1170	1170	1150	1150	1190	1150	1150	1220	1240	1240	1240	4150	
× 448	781	802	822	843	843	864	864	864	864	843	843	884	843	843	905	926	926	926	2440	
× 368	567	584	602	619	619	636	636	636	636	619	619	653	619	619	671	688	688	688	1430	
× 307	422	437	451	466	466	480	480	480	480	466	466	495	466	466	509	524	524	524	849	
× 258	319	331	343	355	355	368	368	368	368	355	355	380	355	355	392	404	404	404	512	
× 235	274	286	297	309	309	320	320	320	320	309	309	331	309	309	343	354	354	354	409	
× 217	237	248	258	268	268	279	279	279	279	268	268	289	268	268	300	310	310	310	310	
× 194	203	212	221	231	231	240	240	240	240	231	231	250	231	231	253	268	268	268	229	
× 178	179	188	197	199	199	199	197	197	197	199	199	224	199	199	233	242	242	242	207	
× 161	158	164	164	164	164	164	174	174	174	164	164	199	164	164	207	216	216	216	157	
× 146	134	134	134	134	134	134	150	150	150	134	134	173	134	134	181	186	186	186	120	
W27 × 129	146	153	161	169	169	170	176	176	176	169	169	184	169	169	192	196	196	196	123	
× 114	122	122	122	122	122	122	137	137	137	122	122	151	122	122	163	165	165	165	101	
× 102	96.9	96.9	96.9	96.9	96.9	96.9	120	120	120	96.9	96.9	130	96.9	96.9	133	135	135	135	74.4	
× 94	78.1	78.1	78.1	78.1	78.1	78.1	106	106	106	78.1	78.1	115	78.1	78.1	118	119	119	119	63.8	
× 84	57.6	57.6	57.6	57.6	57.6	57.6	94.6	94.6	94.6	57.6	57.6	97.7	57.6	57.6	101	102	102	102	53.0	

Table C-1 (cont'd)
Local Column Strength at Wide-Flange Column End Location, $F_y = 50$ ksi
(Wind and Low-Seismic Applications, see Section 1.4)

Shape	Least Design Strength for Local Flange Bending, Local Web Yielding, and Web Crippling ϕR_n , kips																		Web Compr. Buckling ϕR_n , kips
	N, in.																		
	$1/4$		$1/2$		$3/4$		1		$1 1/4$		$1 1/2$		$1 3/4$		2				
	T	C	T	C	T	C	T	C	T	C	T	C	T	C	T	C	T	C	
W24 × 492	1090	1090	1110	1110	1140	1140	1160	1160	1190	1190	1210	1210	1230	1230	1260	1260	1260	4740	
× 408	794	794	815	815	835	835	856	856	877	877	897	897	918	918	938	938	938	2790	
× 335	578	578	595	595	612	612	630	630	647	647	664	664	681	681	699	699	699	1630	
× 279	431	431	446	446	460	460	475	475	489	489	504	504	518	518	533	533	533	971	
× 250	362	362	375	375	388	388	401	401	414	414	427	427	440	440	453	453	453	700	
× 229	312	312	324	324	336	336	348	348	360	360	372	372	384	384	396	396	396	549	
× 207	269	269	280	280	291	291	302	302	313	313	324	324	334	334	345	345	345	410	
× 192	238	238	248	248	258	258	268	268	278	278	289	289	299	299	300	300	300	331	
× 176	209	209	218	218	227	227	237	237	246	246	253	253	255	255	253	253	253	262	
× 162	185	185	194	194	203	203	209	209	220	220	229	229	229	229	209	209	209	218	
× 146	160	160	167	169	177	177	185	185	193	193	197	197	201	201	167	167	167	171	
× 131	130	140	130	147	130	155	130	163	130	170	130	178	130	184	130	187	130	138	
× 117	102	119	102	125	102	132	102	139	102	146	102	149	102	151	102	153	102	103	
× 104	79.1	100	79.1	106	79.1	113	79.1	118	79.1	120	79.1	122	79.1	124	79.1	125	79.1	77.4	
W24 × 103	127	127	134	134	135	141	135	148	135	155	135	157	135	159	135	161	135	103	
× 94	108	111	108	117	108	124	108	130	108	133	108	135	108	137	108	139	108	84.6	
× 84	83.4	97.7	83.4	104	83.4	107	83.4	108	83.4	110	83.4	111	83.4	113	83.4	114	83.4	64.6	
× 76	65.0	84.6	65.0	89.6	65.0	91.0	65.0	92.5	65.0	93.9	65.0	95.3	65.0	96.7	65.0	98.1	65.0	52.8	
× 68	48.1	75.1	48.1	76.5	48.1	77.9	48.1	79.3	48.1	80.7	48.1	82.1	48.1	83.5	48.1	84.9	48.1	44.4	
W24 × 62	49.0	79.3	49.0	81.2	49.0	82.7	49.0	84.2	49.0	85.8	49.0	87.3	49.0	88.9	49.0	90.4	49.0	49.4	
× 55	35.9	65.0	35.9	66.4	35.9	67.8	35.9	69.2	35.9	70.6	35.9	72.0	35.9	73.4	35.9	74.8	35.9	38.4	
W21 × 201	282	282	293	293	304	304	316	316	327	327	338	338	350	350	361	361	361	538	
× 182	244	244	254	254	265	265	275	275	285	285	296	296	306	306	308	308	308	409	
× 166	209	209	218	218	227	227	237	237	246	246	255	255	260	260	260	260	260	302	
× 147	178	178	186	187	186	196	186	205	186	214	186	223	186	232	186	241	186	266	
× 132	151	155	151	164	151	172	151	180	151	188	151	196	151	204	151	212	151	197	
× 122	130	134	130	142	130	149	130	157	130	164	130	172	130	179	130	187	130	154	
× 111	108	119	108	125	108	132	108	139	108	146	108	152	108	154	108	157	108	119	
× 101	90.0	104	90.0	110	90.0	116	90.0	122	90.0	124	90.0	126	90.0	128	90.0	130	90.0	89.4	
W21 × 93	122	130	122	137	122	144	122	151	122	159	122	166	122	172	122	175	122	140	
× 83	98.0	107	98.0	113	98.0	120	98.0	126	98.0	132	98.0	134	98.0	136	98.0	138	98.0	97.3	
× 73	77.0	91.0	77.0	96.7	77.0	100	77.0	102	77.0	103	77.0	105	77.0	107	77.0	108	77.0	67.4	
× 68	66.0	82.6	66.0	87.1	66.0	88.6	66.0	90.1	66.0	91.6	66.0	93.1	66.0	94.6	66.0	96.0	66.0	56.8	
× 62	53.2	72.9	53.2	74.2	53.2	75.6	53.2	76.9	53.2	78.3	53.2	79.6	53.2	80.9	53.2	82.3	53.2	45.8	

Table C-1 (cont'd)
Local Column Strength at Wide-Flange Column End Location, $F_y = 50$ ksi
(Wind and Low-Seismic Applications, see Section 1.4)

Shape	Least Design Strength for Local Flange Bending, Local Web Yielding, and Web Crippling ϕR_n , kips																		Web Compr. Buckling ϕR_n , kips
	M, in.																		
	1/4		1/2		3/4		1		1 1/4		1 1/2		1 3/4		2		C only		
	T	C	T	C	T	C	T	C	T	C	T	C	T	C	T	C			
W21 ×57	59.4	74.7	59.4	77.6	59.4	78.9	59.4	80.2	59.4	81.5	59.4	82.8	59.4	84.1	59.4	85.4	47.3		
×50	40.3	63.1	40.3	64.5	40.3	65.8	40.3	67.1	40.3	68.4	40.3	69.8	40.3	71.1	40.3	72.4	39.3		
×44	28.5	51.3	28.5	52.6	28.5	53.8	28.5	55.1	28.5	56.3	28.5	57.6	28.5	58.8	28.5	60.1	30.6		
W18 ×311	672	672	691	691	710	710	729	729	748	748	767	767	786	786	805	805	2970		
×283	575	575	593	593	610	610	628	628	645	645	663	663	680	680	698	698	2310		
×258	496	496	512	512	528	528	544	544	560	560	576	576	592	592	608	608	1770		
×234	413	413	428	428	442	442	457	457	471	471	486	486	500	500	515	515	1310		
×211	353	353	366	366	379	379	393	393	406	406	419	419	432	432	446	446	1000		
×192	305	305	317	317	329	329	341	341	353	353	365	365	377	377	389	389	746		
×175	261	261	273	273	284	284	295	295	306	306	317	317	328	328	339	339	592		
×158	225	225	235	235	246	246	256	256	266	266	276	276	286	286	296	296	448		
×143	192	192	201	201	210	210	219	219	228	228	237	237	245	245	256	256	328		
130	165	165	174	174	182	182	191	191	199	199	203	203	207	207	224	224	253		
W18 ×119	151	151	158	160	158	168	158	176	158	184	158	192	158	201	158	209	237		
×106	124	127	124	135	124	142	124	149	124	157	124	164	124	171	124	179	173		
×97	106	111	106	118	106	125	106	131	106	138	106	145	106	150	106	152	129		
×86	83.4	92.3	83.4	98.3	83.4	104	83.4	110	83.4	116	83.4	118	83.4	120	83.4	122	93.0		
×76	65.0	78.4	65.0	83.7	65.0	87.4	65.0	89.1	65.0	90.8	65.0	92.5	65.0	94.1	65.0	95.8	64.8		
W18 ×71	92.3	99.0	92.3	105	92.3	111	92.3	118	92.3	124	92.3	126	92.3	128	92.3	131	102		
×65	79.1	86.5	79.1	92.1	79.1	97.7	79.1	101	79.1	103	79.1	105	79.1	107	79.1	109	76.8		
×60	67.9	76.5	67.9	81.7	67.9	84.9	67.9	86.5	67.9	88.0	67.9	89.5	67.9	91.0	67.9	92.6	60.2		
×55	55.8	68.9	55.8	72.5	55.8	73.9	55.8	75.3	55.8	76.7	55.8	78.2	55.8	79.6	55.8	81.0	50.0		
×50	45.7	58.8	45.7	59.9	45.7	61.1	45.7	62.3	45.7	63.5	45.7	64.7	45.7	65.8	45.7	67.0	37.7		
W18 ×46	51.5	60.8	51.5	62.9	51.5	64.1	51.5	65.2	51.5	66.4	51.5	67.5	51.5	68.7	51.5	69.8	39.1		
×40	38.8	47.1	38.8	48.0	38.8	48.9	38.8	49.8	38.8	50.7	38.8	51.6	38.8	52.5	38.8	53.4	26.3		
×35	25.4	39.6	25.4	40.6	25.4	41.5	25.4	42.5	25.4	43.5	25.4	44.5	25.4	45.4	25.4	46.4	22.8		
W16 ×100	131	131	136	138	136	145	136	153	136	160	136	167	136	175	136	182	192		
×89	108	109	108	116	108	122	108	129	108	135	108	142	108	147	108	150	139		
×77	81.2	87.4	81.2	93.1	81.2	96.8	81.2	105	81.2	107	81.2	109	81.2	111	81.2	113	90.1		
×67	62.2	72.8	62.2	76.1	62.2	77.6	62.2	79.1	62.2	80.7	62.2	82.2	62.2	83.8	62.2	85.3	59.2		

Shape		Local Column Strength at Wide-Flange Column End Location, $F_y = 50$ ksi (Wind and Low-Seismic Applications, see Section 1.4)																								Web Compr. Buckling ϕR_n , kips			
		Least Design Strength for Local Flange Bending, Local Web Yielding, and Web Crippling ϕR_n , kips																											
		N, in.																											
		1/4		1/2		3/4		1		1 1/4		1 1/2		1 3/4		2		C	C	C	C	C	C	C	C		C		
T	C	T	C	T	C	T	C	T	C	T	C	T	C	T	C	T	C									T		C	T
W16x57	71.9	79.3	71.9	84.7	71.9	90.0	93.3	71.9	95.1	71.9	97.0	71.9	98.8	71.9	98.8	71.9	98.8	71.9	98.8	71.9	98.8	71.9	98.8	71.9	98.8	71.9	98.8	101	75.8
	55.8	67.1	55.8	69.9	55.8	71.4	55.8	72.8	55.8	74.3	55.8	75.7	55.8	77.2	55.8	77.2	55.8	77.2	55.8	77.2	55.8	77.2	55.8	77.2	55.8	77.2	55.8	78.6	52.5
	44.9	56.1	44.9	57.4	44.9	58.6	44.9	59.8	44.9	61.0	44.9	62.2	44.9	63.5	44.9	63.5	44.9	63.5	44.9	63.5	44.9	63.5	44.9	63.5	44.9	63.5	44.9	64.7	39.3
	35.9	44.1	35.9	45.1	35.9	46.0	35.9	47.0	35.9	47.9	35.9	48.9	35.9	49.8	35.9	49.8	35.9	49.8	35.9	49.8	35.9	49.8	35.9	49.8	35.9	49.8	35.9	50.8	27.1
W16x31	27.2	35.3	27.2	36.1	27.2	36.9	27.2	37.7	27.2	38.5	27.2	39.3	27.2	40.1	27.2	40.1	27.2	40.1	27.2	40.1	27.2	40.1	27.2	40.1	27.2	40.1	27.2	40.9	19.9
	16.7	27.3	16.7	28.0	16.7	28.8	16.7	29.6	16.7	30.4	16.7	31.2	16.7	31.9	16.7	31.9	16.7	31.9	16.7	31.9	16.7	31.9	16.7	31.9	16.7	31.9	16.7	32.7	15.0
W14x808	2760	2760	2810	2810	2860	2860	2900	2950	2950	2950	3000	3000	3050	3050	3050	3050	3050	3050	3050	3050	3050	3050	3050	3050	3050	3050	3050	3090	60900
	2170	2170	2210	2210	2250	2250	2290	2330	2330	2330	2370	2370	2400	2400	2400	2400	2400	2400	2400	2400	2400	2400	2400	2400	2400	2400	2400	2440	33400
	1870	1870	1910	1910	1940	1940	1980	2010	2010	2010	2050	2050	2080	2080	2080	2080	2080	2080	2080	2080	2080	2080	2080	2080	2080	2080	2080	2120	26200
	1590	1590	1630	1630	1660	1660	1690	1720	1720	1720	1760	1760	1790	1790	1790	1790	1790	1790	1790	1790	1790	1790	1790	1790	1790	1790	1790	1820	20200
	1370	1370	1400	1400	1430	1430	1460	1490	1490	1490	1520	1520	1550	1550	1550	1550	1550	1550	1550	1550	1550	1550	1550	1550	1550	1550	1580	15600	
	1170	1170	1200	1200	1230	1230	1260	1280	1280	1280	1310	1310	1340	1340	1340	1340	1340	1340	1340	1340	1340	1340	1340	1340	1340	1340	1370	12200	
W14x426	1000	1000	1030	1030	1050	1050	1080	1100	1100	1100	1130	1130	1150	1150	1150	1150	1150	1150	1150	1150	1150	1150	1150	1150	1150	1150	1180	9470	
	888	888	911	911	935	935	958	981	981	981	1000	1000	1030	1030	1030	1030	1030	1030	1030	1030	1030	1030	1030	1030	1030	1030	1050	7610	
W14x398	797	797	819	819	841	841	863	885	885	885	907	907	929	929	929	929	929	929	929	929	929	929	929	929	929	929	951	6410	
	706	706	727	727	747	747	768	789	789	789	809	809	830	830	830	830	830	830	830	830	830	830	830	830	830	830	851	5240	
W14x342	621	621	640	640	659	659	679	698	698	698	717	717	736	736	736	736	736	736	736	736	736	736	736	736	736	736	756	4220	
	535	535	553	553	571	571	588	606	606	606	623	623	641	641	641	641	641	641	641	641	641	641	641	641	641	641	659	3250	
W14x283	460	460	476	476	492	492	508	524	524	524	540	540	556	556	556	556	556	556	556	556	556	556	556	556	556	556	572	2490	
	391	391	406	406	420	420	435	450	450	450	464	464	479	479	479	479	479	479	479	479	479	479	479	479	479	479	494	1880	
W14x233	331	331	344	344	358	358	371	385	385	385	398	398	411	411	411	411	411	411	411	411	411	411	411	411	411	411	416	1420	
	288	288	300	300	312	312	325	337	337	337	349	349	361	361	361	361	361	361	361	361	361	361	361	361	361	361	374	1090	
W14x193	248	248	259	259	270	270	281	292	292	292	299	299	314	314	314	314	314	314	314	314	314	314	314	314	314	314	325	819	
	218	218	228	228	239	239	249	261	261	261	270	270	280	280	280	280	280	280	280	280	280	280	280	280	280	280	291	665	
W14x159	184	184	193	193	199	199	209	219	219	219	228	228	241	241	241	241	241	241	241	241	241	241	241	241	241	241	249	480	
	157	157	166	166	167	167	174	183	183	183	191	191	199	199	199	199	199	199	199	199	199	199	199	199	199	209	217	364	

Table C-1 (cont'd)
Local Column Strength at Wide-Flange Column End Location, $F_y = 50$ ksi
(Wind and Low-Seismic Applications, see Section 1.4)

Shape	Least Design Strength for Local Flange Bending, Local Web Yielding, and Web Crippling ϕR_n , kips																				Web Compr. Buckling ϕR_n , kips
	N, in.																				
	1/4		1/2		3/4		1		1 1/4		1 1/2		1 3/4		2		C only				
	T	C	T	C	T	C	T	C	T	C	T	C	T	C	T	C					
W14 ×132	144	149	152	160	149	149	168	149	176	149	184	149	192	149	201	310					
×120	124	124	135	142	124	124	149	124	157	124	164	124	171	124	179	239					
×109	104	104	116	122	104	104	129	104	135	104	142	104	148	104	153	169					
×99	85.6	85.6	93.3	105	85.6	85.6	111	85.6	117	85.6	124	85.6	127	85.6	130	132					
×90	70.9	70.9	86.6	92.1	70.9	70.9	97.6	70.9	100	70.9	103	70.9	105	70.9	107	98.6					
W14 ×82	103	103	116	123	103	103	129	103	135	103	139	103	142	103	145	156					
×74	86.7	86.7	99.1	103	86.7	86.7	105	86.7	108	86.7	110	86.7	112	86.7	114	108					
×68	72.9	72.9	85.6	87.5	72.9	72.9	89.5	72.9	91.4	72.9	93.3	72.9	95.2	72.9	97.1	84.5					
×61	58.5	58.5	69.7	71.3	58.5	58.5	72.9	58.5	74.5	58.5	76.1	58.5	77.7	58.5	79.2	62.5					
W14 ×53	61.3	61.3	68.9	70.4	61.3	61.3	71.9	61.3	73.4	61.3	74.9	61.3	76.4	61.3	77.9	59.8					
×48	49.8	49.8	57.7	59.0	49.8	49.8	60.3	49.8	61.6	49.8	62.9	49.8	64.2	49.8	65.5	46.4					
×43	39.5	39.5	46.3	47.4	39.5	39.5	48.5	39.5	49.5	39.5	50.6	39.5	51.6	39.5	52.7	33.5					
W14 ×38	37.3	37.3	46.9	48.0	37.3	37.3	49.1	37.3	50.2	37.3	51.3	37.3	52.4	37.3	53.5	32.5					
×34	29.1	29.1	39.0	40.0	29.1	29.1	40.9	29.1	41.9	29.1	42.9	29.1	43.9	29.1	44.9	25.2					
×30	20.8	20.8	33.4	34.4	20.8	20.8	35.4	20.8	36.4	20.8	37.4	20.8	38.4	20.8	39.4	21.5					
W14 ×26	24.8	24.8	31.6	32.4	24.8	24.8	33.2	24.8	33.9	24.8	34.7	24.8	35.5	24.8	36.2	18.0					
×22	15.8	15.8	24.5	25.2	15.8	15.8	25.9	15.8	26.6	15.8	27.3	15.8	28.0	15.8	28.7	13.2					
W12 ×336	840	863	863	885	885	885	907	907	929	929	951	973	973	996	996	7730					
×305	719	739	739	759	759	759	779	779	800	800	820	840	840	861	861	5930					
×279	629	648	648	667	667	667	686	686	705	705	724	743	743	763	763	4930					
×252	530	547	547	565	565	565	582	582	599	599	617	634	634	652	652	3710					
×230	458	474	474	490	490	490	506	506	522	522	538	554	554	570	570	2900					
×210	402	417	417	431	431	431	446	446	461	461	476	490	490	505	505	2270					
×190	336	349	349	363	363	363	376	376	389	389	402	416	416	423	423	1640					
×170	282	294	294	306	306	306	318	318	330	330	342	342	354	342	366	1210					
×152	242	253	253	264	264	264	275	275	276	276	296	276	307	276	318	908					
×136	201	211	211	220	220	220	231	231	220	241	220	251	220	220	270	675					
×120	170	172	172	187	187	187	196	196	172	205	172	214	172	223	232	492					
×106	136	138	138	144	138	138	159	138	167	138	174	138	182	138	190	311					
×96	114	114	114	125	114	114	139	114	146	114	153	114	160	114	167	229					
×87	92.3	92.3	92.3	109	92.3	92.3	122	92.3	129	92.3	135	92.3	142	92.3	148	187					
×79	76.0	76.0	76.0	86.2	76.0	76.0	108	76.0	114	76.0	118	76.0	121	76.0	124	143					
×72	63.1	63.1	63.1	74.9	63.1	63.1	93.7	63.1	96.3	63.1	99.0	63.1	102	63.1	104	109					
×65	51.5	51.5	51.5	61.5	51.5	51.5	77.1	51.5	79.3	51.5	81.4	51.5	83.6	51.5	85.8	81.5					

Table C-1 (cont'd)
Local Column Strength at Wide-Flange Column End Location, $F_y = 50$ ksi
(Wind and Low-Seismic Applications, see Section 1.4)

Shape	Least Design Strength for Local Flange Bending, Local Web Yielding, and Web Crippling ϕR_n , kips																								Web Compr. Buckling ϕR_n , kips
	M, in.																								
	1/4		1/2		3/4		1		1 1/4		1 1/2		1 3/4		2		C	C only							
	T	C	T	C	T	C	T	C	T	C	T	C	T	C	T	C									
W12×58 ×53	57.6 46.5	63.9 57.0	57.6 46.5	65.6 58.6	57.6 46.5	67.2 60.2	57.6 46.5	68.8 61.8	70.4 63.4	57.6 46.5	72.0 65.0	57.6 46.5	73.6 66.6	57.6 46.5	75.3 68.2	57.6 46.5	73.6 66.6	64.5 56.0							
W12×50 ×45 ×40	57.6 46.5 37.3	66.7 54.5 42.6	57.6 46.5 37.3	68.4 56.0 43.7	57.6 46.5 37.3	70.2 57.4 44.9	57.6 46.5 37.3	72.0 58.9 46.0	73.7 60.4 47.1	57.6 46.5 37.3	75.5 61.8 48.2	57.6 46.5 37.3	77.2 63.3 49.4	57.6 46.5 37.3	79.0 64.8 50.5	57.6 46.5 37.3	77.2 63.3 49.4	70.0 51.3 35.5							
W12×35 ×30 ×26	38.0 27.2 20.3	41.3 32.6 25.2	38.0 27.2 20.3	45.0 33.5 25.9	38.0 27.2 20.3	46.1 34.3 26.6	38.0 27.2 20.3	47.2 35.2 27.4	48.3 36.1 28.1	38.0 27.2 20.3	49.5 37.0 28.8	38.0 27.2 20.3	50.6 37.8 29.5	38.0 27.2 20.3	51.7 38.7 30.2	38.0 27.2 20.3	50.6 37.8 29.5	33.5 21.9 15.2							
W12×22 ×19 ×16 ×14	25.4 17.2 9.88 7.12	31.7 25.1 20.1 16.1	25.4 17.2 9.88 7.12	33.0 26.0 21.0 16.9	25.4 17.2 9.88 7.12	33.9 26.8 21.9 17.7	25.4 17.2 9.88 7.12	34.8 27.6 22.8 18.5	35.7 28.4 23.7 19.3	25.4 17.2 9.88 7.12	36.6 29.3 24.6 20.1	25.4 17.2 9.88 7.12	37.5 30.1 25.5 21.0	25.4 17.2 9.88 7.12	38.4 30.9 26.4 21.8	25.4 17.2 9.88 7.12	37.5 30.1 25.5 21.0	21.7 16.1 13.2 9.91							
W10×112 ×100 ×88 ×77 ×68 ×60 ×54 ×49	186 157 130 106 83.4 65.0 53.2 44.1	186 166 138 106 83.4 65.0 53.2 44.1	196 166 138 106 83.4 65.0 53.2 44.1	196 166 138 106 83.4 65.0 53.2 44.1	205 174 138 106 83.4 65.0 53.2 44.1	205 174 138 106 83.4 65.0 53.2 44.1	215 183 153 126 104 89.9 72.5 61.1	215 176 138 106 83.4 65.0 53.2 44.1	224 191 161 133 110 95.2 74.7 63.0	220 176 138 106 83.4 65.0 53.2 44.1	234 200 168 139 116 98.2 76.9 64.9	220 176 138 106 83.4 65.0 53.2 44.1	243 208 176 146 122 101 79.1 66.8	220 176 138 106 83.4 65.0 53.2 44.1	252 217 183 152 128 104 81.3 68.7	220 176 138 106 83.4 65.0 53.2 44.1	243 208 176 146 122 101 79.1 66.8	798 540 381 256 177 127 87.1 67.4							
W10×45 ×39 ×33	54.1 39.5 26.6	59.1 48.0 38.7	54.1 39.5 26.6	62.5 49.6 40.3	54.1 39.5 26.6	64.4 51.2 41.8	54.1 39.5 26.6	66.2 52.8 43.4	68.1 54.5 44.9	54.1 39.5 26.6	69.9 56.1 46.5	54.1 39.5 26.6	71.8 57.7 48.1	54.1 39.5 26.6	73.6 59.3 49.7	54.1 39.5 26.6	71.8 57.7 48.1	41.0 26.7 20.8							
W10×30 ×26 ×22	36.6 27.2 18.2	38.9 31.7 25.5	36.6 27.2 18.2	42.7 33.8 27.5	36.6 27.2 18.2	46.4 34.9 28.5	36.6 27.2 18.2	47.8 35.9 29.5	49.2 36.9 30.5	36.6 27.2 18.2	50.5 38.0 31.6	36.6 27.2 18.2	51.9 39.0 32.6	36.6 27.2 18.2	53.3 40.1 33.6	36.6 27.2 18.2	51.9 39.0 32.6	41.0 26.7 20.8							
W10×19 ×17 ×15 ×12	21.9 15.3 10.3 6.20	28.5 25.5 21.9 14.6	21.9 15.3 10.3 6.20	30.4 26.6 23.1 15.5	21.9 15.3 10.3 6.20	31.5 27.7 24.3 16.4	21.9 15.3 10.3 6.20	32.5 28.8 25.5 17.3	33.6 30.0 26.8 18.2	21.9 15.3 10.3 6.20	34.6 31.1 28.0 19.1	21.9 15.3 10.3 6.20	35.6 32.2 29.2 20.0	21.9 15.3 10.3 6.20	36.7 33.3 30.4 20.9	21.9 15.3 10.3 6.20	35.6 32.2 29.2 20.0	23.7 20.9 18.4 10.4							

Shape		Local Column Strength at Wide-Flange Column End Location, $F_y = 50$ ksi (Wind and Low-Seismic Applications, see Section 1.4)																		Web Compr. Buckling ϕR_n , kips					
		Least Design Strength for Local Flange Bending, Local Web Yielding, and Web Crippling ϕR_n , kips																							
		M, in.																							
		$\frac{1}{4}$			$\frac{1}{2}$			$\frac{3}{4}$			1			$1\frac{1}{4}$			$1\frac{1}{2}$				$1\frac{3}{4}$			2	
T	C	T	T	C	T	T	C	T	T	C	T	T	C	T	T	C	T	T	C	T	T	C	T	C only	
W8×67	110	117	117	124	123	123	131	123	138	145	123	123	123	145	123	123	123	123	123	123	123	123	123	159	394
×58	90.0	92.3	92.3	103	92.3	92.3	109	92.3	116	122	92.3	92.3	92.3	122	92.3	92.3	92.3	92.3	92.3	92.3	92.3	92.3	92.3	135	283
×48	64.4	66.0	66.0	74.4	66.0	66.0	79.4	66.0	84.4	89.4	66.0	66.0	66.0	89.4	66.0	66.0	66.0	66.0	66.0	66.0	66.0	66.0	66.0	99.4	136
×40	44.1	44.1	44.1	61.3	44.1	44.1	65.8	44.1	70.3	74.7	44.1	44.1	44.1	74.7	44.1	44.1	44.1	44.1	44.1	44.1	44.1	44.1	44.1	81.4	99.4
×35	34.5	34.5	34.5	49.8	34.5	34.5	51.8	34.5	53.8	55.8	34.5	34.5	34.5	55.8	34.5	34.5	34.5	34.5	34.5	34.5	34.5	34.5	34.5	60.8	63.5
×31	26.6	26.6	26.6	41.6	26.6	26.6	43.4	26.6	45.2	47.0	26.6	26.6	26.6	47.0	26.6	26.6	26.6	26.6	26.6	26.6	26.6	26.6	26.6	51.5	49.3
W8×28	30.4	30.4	30.4	42.4	30.4	30.4	44.1	30.4	45.8	47.4	30.4	30.4	30.4	47.4	30.4	30.4	30.4	30.4	30.4	30.4	30.4	30.4	30.4	51.6	48.8
×24	22.5	28.9	22.5	31.4	22.5	22.5	32.7	22.5	33.9	35.2	22.5	22.5	22.5	35.2	22.5	22.5	22.5	22.5	22.5	22.5	22.5	22.5	22.5	38.4	31.0
W8×21	22.5	28.5	22.5	32.3	22.5	22.5	33.6	22.5	34.9	36.2	22.5	22.5	22.5	36.2	22.5	22.5	22.5	22.5	22.5	22.5	22.5	22.5	22.5	39.3	30.6
×18	15.3	24.1	15.3	26.5	15.3	15.3	27.8	15.3	29.0	30.2	15.3	15.3	15.3	30.2	15.3	15.3	15.3	15.3	15.3	15.3	15.3	15.3	15.3	33.3	23.9
W8×15	14.0	26.0	14.0	29.2	14.0	14.0	30.8	14.0	32.3	33.9	14.0	14.0	14.0	33.9	14.0	14.0	14.0	14.0	14.0	14.0	14.0	14.0	14.0	37.8	29.0
×13	9.14	21.7	9.14	24.9	9.14	9.14	26.5	9.14	28.2	29.8	9.14	9.14	9.14	29.8	9.14	9.14	9.14	9.14	9.14	9.14	9.14	9.14	9.14	33.9	24.0
×10	5.91	12.3	5.91	13.9	5.91	5.91	14.7	5.91	15.6	16.4	5.91	5.91	5.91	16.4	5.91	5.91	5.91	5.91	5.91	5.91	5.91	5.91	5.91	18.5	9.65
W6×25	29.1	36.5	29.1	44.5	29.1	29.1	48.5	29.1	52.5	56.5	29.1	29.1	29.1	56.5	29.1	29.1	29.1	29.1	29.1	29.1	29.1	29.1	29.1	64.5	89.9
×20	18.7	27.6	18.7	34.1	18.7	18.7	37.3	18.7	39.4	42.2	18.7	18.7	18.7	42.2	18.7	18.7	18.7	18.7	18.7	18.7	18.7	18.7	18.7	47.8	48.8
×15	9.51	20.8	9.51	23.7	9.51	9.51	28.7	9.51	31.0	33.8	9.51	9.51	9.51	33.8	9.51	9.51	9.51	9.51	9.51	9.51	9.51	9.51	9.51	39.4	33.5
W6×16	23.1	27.6	23.1	34.1	23.1	23.1	37.4	23.1	39.8	42.2	23.1	23.1	23.1	42.2	23.1	23.1	23.1	23.1	23.1	23.1	23.1	23.1	23.1	47.2	48.0
×12	11.0	20.8	11.0	26.6	11.0	11.0	28.8	11.0	30.9	33.5	11.0	11.0	11.0	33.5	11.0	11.0	11.0	11.0	11.0	11.0	11.0	11.0	11.0	38.7	33.2
×9	6.50	12.8	6.50	14.9	6.50	6.50	15.9	6.50	17.1	18.5	6.50	6.50	6.50	18.5	6.50	6.50	6.50	6.50	6.50	6.50	6.50	6.50	6.50	21.2	13.4
W5×19	26.0	30.8	26.0	37.5	26.0	26.0	40.9	26.0	44.3	47.7	26.0	26.0	26.0	47.7	26.0	26.0	26.0	26.0	26.0	26.0	26.0	26.0	26.0	54.4	72.8
×16	18.2	25.5	18.2	31.5	18.2	18.2	33.7	18.2	36.5	39.3	18.2	18.2	18.2	39.3	18.2	18.2	18.2	18.2	18.2	18.2	18.2	18.2	18.2	44.8	51.4
W4×13	16.7	27.6	16.7	34.6	16.7	16.7	38.1	16.7	41.6	45.1	16.7	16.7	16.7	45.1	16.7	16.7	16.7	16.7	16.7	16.7	16.7	16.7	16.7	52.1	103

Appendix D

COLUMN STIFFENING CONSIDERATIONS FOR WEAK-AXIS MOMENT CONNECTIONS

Pages 10-61 through 10-65 of the 2nd edition of the LRFD *Manual of Steel Construction* and the reference Ferrell (1998) have been reprinted in this appendix for ease of reference.

FROM AISC (1994):

Special Considerations

FR Moment Connections to Column-Web Supports

It is frequently required that FR moment connections be made to column web supports. While the mechanics of analysis and design do not differ from FR moment connection to column flange supports, the details of the connection design as well as the ductility considerations required are significantly different.

Recommended Details. When an FR moment connection is made to a column web, it is normal practice to stop the beam short and locate all bolts outside of the column flanges This simplifies the erection of the beam and permits the use of an impact wrench to tighten all bolts. It is also preferable to locate welds outside the column flanges to provide adequate clearance.

Ductility Considerations. Driscoll and Beedle (1982) discuss the testing and failure of two FR moment connections to column-web supports: a directly welded flange connection and a bolted flange-plated connection, shown respectively in Figures 10-25a and 10-25b. Although the connections in these tests were proportioned to be “critical,” they were expected to provide inelastic rotations at full plastic load. Failure occurred unexpectedly, however, on the first cycle of loading; brittle fracture occurred in the tension connection plate at the load corresponding to the plastic moment before significant inelastic rotation had occurred.

Examination and testing after the unexpected failure revealed that the welds were of proper size and quality and that the plate had normal strength and ductility. The following is quoted, with minor editorial changes relative to figure numbers, directly from Driscoll and Beedle (1982).

“Calculations indicate that the failures occurred due to high strain concentrations. These concentrations are: (1) at the junction of the connection plate and the column flange tip and (2) at the edge of the butt weld joining the beam flange and the connection plate.

“Figure 10-26 illustrates the distribution of longitudinal stress across the width of the connection plate and the concentration of stress in the plate at the column flange tips. It also illustrates the uniform longitudinal stress distribution in the connection plate at some distance away from the connection. The stress distribution shown represents schematically the values measured during the load tests and those obtained from finite element analysis. (σ_o is a nominal stress in the elastic range.) The results of the analyses are valid up to the loading that causes the combined stress to equal the yield point. Furthermore, the analyses indicate that localized yielding could begin when the applied uniform stress is less than one-third of the yield point. Another contribution of the non-uniformity is the fact that there is no back-up stiffener. This means that the welds to the web near its center are not fully effective.

“The longitudinal stresses in the moment connection plate introduce strains in the transverse and the through-thickness directions (the Poisson effect). Because of the attachment of the connection plate to the column flanges, restraint is introduced; this causes tensile stresses in the transverse and the through-thickness directions. Thus, referring to Figure 10-26, tri-axial tensile stresses are present along Section A-A, and they are at their maximum values at the intersections of Sections A-A and C-C. In such a situation, and when the magnitudes of the stresses are sufficiently high, materials that are otherwise ductile may fail by premature brittle fracture.”

The results of nine simulated weak-axis FR moment connection tests performed by Driscoll et al. (1983) are summarized in Figure 10-27. In these tests, the beam flange was simulated by a plate measuring either 1 in. \times 10 in. or 1 1/8 in. \times 9 in. The fracture strength exceeds the yield strength in every case, and sufficient ductility is provided in all cases except for that of Specimen D. Also, if the rolling direction in the first five specimens (A, B, C, D, and E) were parallel to the loading direction, which would more closely approximate an actual beam flange, the ductility ratios for these would be higher. The connections with extended connection plates (i.e., projection of three inches), with extensions either rectangular or tapered, appeared equally suitable for the static loads of the tests.

Based on the tests, Driscoll et al. (1983) report that those specimens with extended connection plates have better toughness and ductility and are preferred in design for

seismic loads, even though the other connection types (except D) may be deemed adequate to meet the requirements of many design situations.

In accordance with the preceding discussion, the following suggestions are made regarding the design of this type of connection:

1. For directly welded (butt) flange-to-plate connections, the connection plate should be thicker than the

beam flange. This greater area accounts for shear lag and also provides for misalignment tolerances.

AWS D1.1, Section 3.3.3 restricts the misalignment of abutting parts such as this to 10 percent of the thickness, with $\frac{1}{8}$ in. maximum for a part restrained against bending due to eccentricity of alignment. Considering the various tolerances in mill rolling ($\pm \frac{1}{8}$ in. for W-shapes), fabrication, and erection, it is prudent design to call for the stiffener thickness

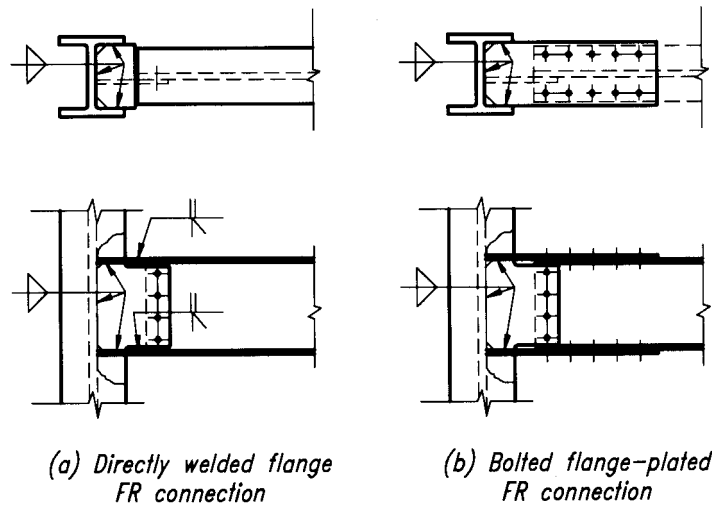
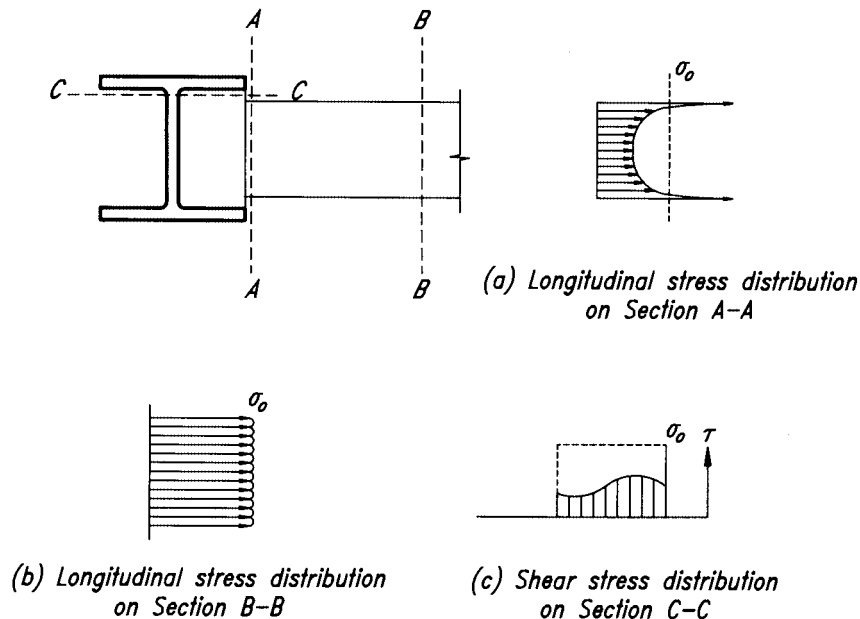

Figure 10-25 Test specimens used by Driscoll and Beedle (1982).



$\sigma_o =$ the nominal stress in the elastic range

Figure 10-26 Stress distributions in test specimens used by Driscoll and Beedle (1982).

to be increased to accommodate these tolerances and avoid the subsequent problems encountered at erection. An increase of 1/8 in. to 1/4 in. generally is used.

Frequently, this connection plate also serves as the stiffener for a strong-axis FR or PR moment connection. The welds which attach the plate/stiffener to the column flange may then be subjected to combined tensile and shearing or compression and shearing forces. Vector analysis is commonly used to determine weld size and stress.

It is good practice to use fillet welds whenever possible. Welds should not be made in the column fillet area for strength.

2. The connection plate should extend at least 3/4 in. beyond the column flange to avoid intersecting welds and to provide for strain elongation of the plate.

The extension should also provide adequate room for runout bars when required.

3. Tapering an extended connection plate is only necessary when the connection plate is not welded to the column web (Specimen E, Figure 10-27). Tapering is not necessary if the flange force is always compressive (e.g., at the bottom flange of a cantilevered beam).
4. To provide for increased ductility under seismic loading, a tapered connection plate should extend three inches. Alternatively, a backup stiffener and an untapered connection plate with 3-in. extension could be used.

Normal and acceptable quality of workmanship for connections involving gravity and wind loading in building construction would tolerate the following:

Specimen No.	Sketch W14x257(typical)	Fracture Load (kips)	Fracture Load / Yield Load	Ductility Ratio
A		730	1.38	6.3
B		824	1.55	5.3
C		756	1.43	5.43
D		570	1.11	1.71

Figure 10-27a Results of weak-axis FR connection ductility tests performed by Driscoll et al. (1983).

Specimen No.	Sketch W14x257(typical)	Fracture Load (kips)	$\frac{\text{Fracture Load}}{\text{Yield Load}}$	Ductility Ratio
E		802	1.51	6.81
A2		762	1.40	17.7
B2		795	1.46	16.5
E2		814	1.49	16.4 ^(b)
C2		813	1.49	29.6

Notes: (a) $\frac{3}{4}$ " dimension is estimated—no dimension given.

(b) Ductility ratio estimated. Actual value not known due to malfunction in deflection gage.

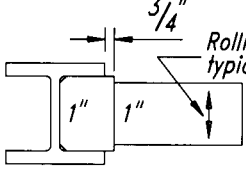
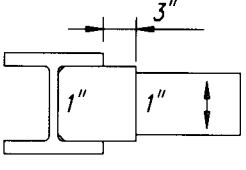
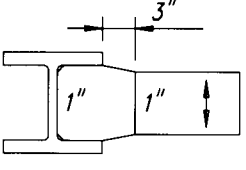
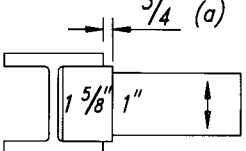
Figure 10-27b Results of weak-axis FR connection ductility tests performed by Driscoll et al. (1983).

1. Runoff bars and backing bars may be left in place for Groups 4 and 5 beams (subject to tensile stress only) where they are welded to columns or used as tension members in a truss.
2. Welds need not be ground, except as required for nondestructive testing.
3. Connection plates that are made thicker or wider for control of tolerances, tensile stress, and shear lag need not be ground or cut to a transition thickness or width to match the beam flange to which they connect.
4. Connection plate edges may be sheared or plasma or gas cut.
5. Intersections and transitions may be made without fillets or radii.
6. Burned edges may have reasonable roughness and notches within AWS tolerances.

If a structure is subjected to loads other than gravity and wind loads, such as seismic, dynamic, or fatigue loading, more stringent control of the quality of fabrication and erection with regard to stress risers, notches, transition geometry, welding, and testing may be necessary; refer to AISC's *Seismic Provisions for Structural Steel Buildings*.

FROM FERRELL (1998):

Moment Connections to Column Webs

(M. Thomas Ferrell, Ferrell Engineering, Inc.)

Introduction

Details for moment connections to column webs must consider mill and shop tolerances of the structural members and provide for material ductility. This paper will present details which will accommodate these requirements and present limit state strength considerations for both moment connections with field welded beam flanges and field bolted flange plates.

Moment Connection with Field Welded Beam Flanges

Figure 1 illustrates a field welded flange moment connection.

1. The connection plates must be the same grade of material as the weak-axis moment beam.
2. The connection plate has been extended $\frac{3}{4}$ in. minimum beyond the column flange to provide better toughness and ductility. AISC Load and Resistance Factor Design [Manual] Volume II, pages 10-60 through 10-65, has summarized results of nine simulated weak-axis FR moment connection tests performed by Driscoll et al. to aid in selection of details to ensure ductility.
3. The top connection plate thickness is equal to t_f plus $\frac{1}{4}$ in. This additional thickness is necessary to

MOMENT CONN.'s w/ Field Welded Bm. Flg's.

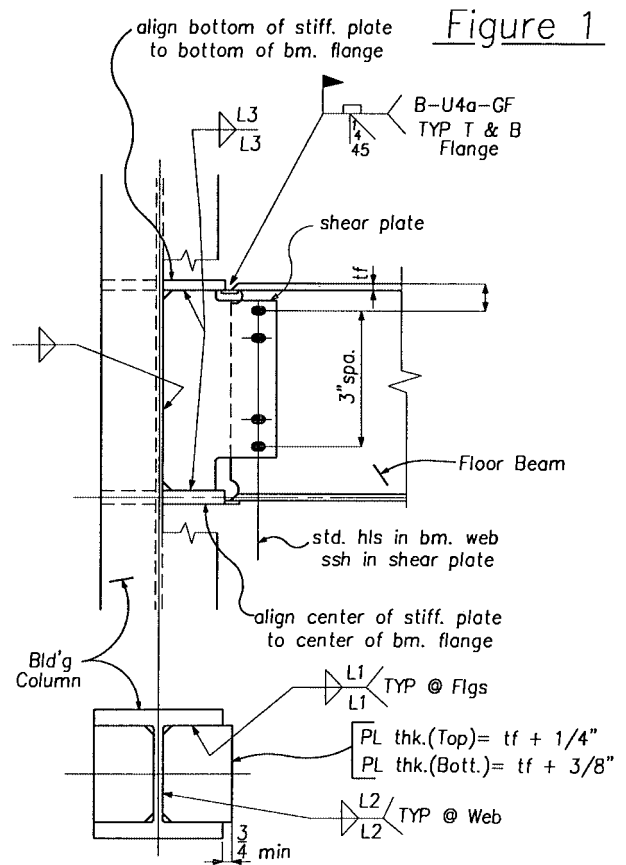

accommodate tolerances for fabrication and beam flange tilt. Note that the bottom of this connection plate is aligned with the bottom of the beam top flange.

4. The bottom connection plate thickness is equal to t_f plus $\frac{3}{8}$ in. This is necessary to accommodate tolerances for fabrication and beam flange tilt plus possible overrun/underrun in the beam depth. Note that the centerline of this connection plate is aligned with the centerline of the bottom flange of the beam.
5. The welds for connection plates to the column flanges must be designed for shear forces. These welds may also be subjected to tensile/compression and shear forces when these plates serve as stiffener plates for a strong-axis moment beam. Use fillet welds where possible. It is good practice to deduct twice the weld size from the length of plate available for welding so that the welds do not terminate at the edges of the plate or column flange. If calculated stresses are transferred through the welds at the column web, then backup stiffeners must be provided.
6. Bolts for the shear plate to beam web are normally located outside of the column flanges. This practice simplifies beam erection and allows access to tighten

the bolts with use of an impact wrench. Short slots should be used in the plate and standard holes in the beam web. Flange welds should be completed before the bolts are tightened. The short slots will "hold" top of beam elevation and allow for weld shrinkage to occur at the flange welds. The bolts are designed for shear forces only (no eccentricity). The welds for the shear plate to column web are designed for shear only. The welds for the shear plate to connection plates must be designed for shear stresses due to the eccentricity from the neutral axis of the bolt group to the edge of the column flange. If a column web doubler is required due to a strong-axis moment beam, then the additional stresses from the shear plate must be considered in determining the thickness of the web doubler plate.

Moment Connections with Beam Flange Plates

Figure 2 illustrates a field bolted flange plate moment connection.

1. It is not necessary for the flange plates to be the same grade of material as the weak-axis moment beam.
2. Oversized holes should be used in the flange plates to allow for mill tolerances in the column and beam.

MOMENT CONN.'s with Beam Flange Plates

Figure 2

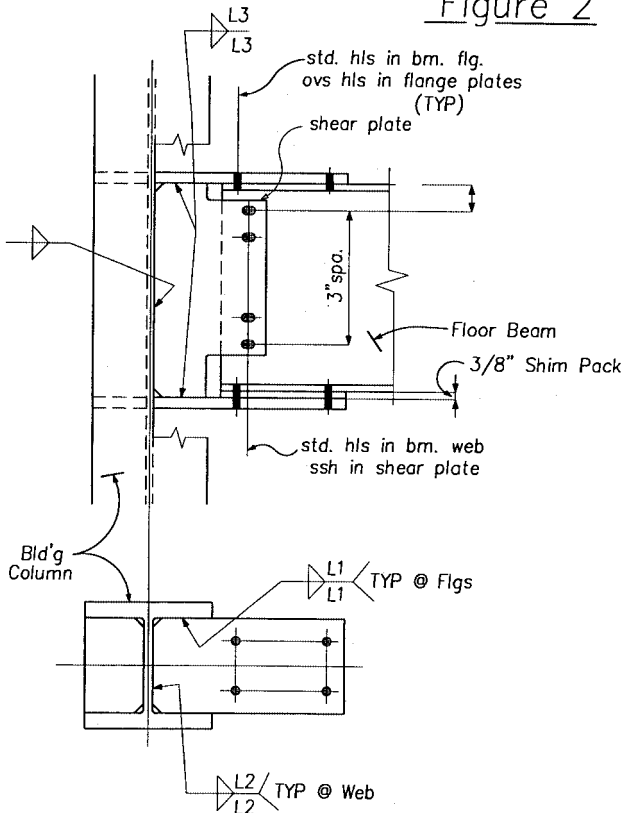

These connections with oversized holes must be designed as slip critical. If tension control bolts are used, if possible, use a bolt gage which will allow bolts at the bottom flange to be tightened from the inside of the beam flange. In many cases this is not possible due to beam flange widths and beam depths.

3. Shims must be provided at the top or bottom flanges to accommodate fabrication and mill tolerances for flange tilt plus possible overrun/underrun in beam depths. Fabricators normally prefer the shims to be at the bottom flange due to restrictions on programming of shop equipment. If shims are provided at the top flange, the detail can be provided to serve as a deck support (Figure 3).
4. The flange plates must be designed for tension yielding, tension rupture, and compression strength.
5. The flange bolts must be designed for shear strength.
6. The beam design flexural strength with regard to net section must be determined to assure that the net beam section is adequate without reinforcing.
7. The welds for the flange plates to the column flanges/webs are designed using the same criteria used for the connection plates for the field welded flange moment beams in Figure 1.
8. The web shear plate design is the same as for the field welded flange moment beams.

MOMENT CONN.'s with Beam Flange Plates

Figure 3

