

# Facts for Steel Buildings

---

number **1**

# Fire

**Richard G. Gewain**  
Hughes Associates, Inc.

**Nestor R. Iwankiw**  
Hughes Associates, Inc.

**Farid Alfawakhiri**  
AISC, Inc.



Copyright © 2003

by

American Institute of Steel Construction, Inc.

*All rights reserved. This book or any part thereof  
must not be reproduced in any form without the  
written permission of the publisher.*

The information presented in this publication has been prepared in accordance with recognized engineering principles and is for general information only. While it is believed to be accurate, this information should not be used or relied upon for any specific application without competent professional examination and verification of its accuracy, suitability, and applicability by a licensed professional engineer, designer, or architect. The publication of the material contained herein is not intended as a representation or warranty on the part of the American Institute of Steel Construction or of any other person named herein, that this information is suitable for any general or particular use or of freedom from infringement of any patent or patents. Anyone making use of this information assumes all liability arising from such use.

Caution must be exercised when relying upon other specifications and codes developed by other bodies and incorporated by reference herein since such material may be modified or amended from time to time subsequent to the printing of this edition. The Institute bears no responsibility for such material other than to refer to it and incorporate it by reference at the time of the initial publication of this edition.

Printed in the United States of America

First Printing: October 2003



**In memory of  
Richard G. Gewain  
1929–2003**

A renowned fire protection engineer and building code expert, Richard G. Gewain died on February 13, 2003 after complications from heart surgery. This document was one of the last engineering projects that Dick was working on prior to his death, and it is dedicated to his memory.

Since 1986, Dick was a Senior Engineer with the consulting firm of Hughes Associates, Inc. in Baltimore, MD. He specialized in developing and reviewing active and passive fire protection systems, as well as performance-based engineering to predict realistic fire exposures and the fire resistance criteria. His consulting work encompassed design work in a multitude of fire exposure applications and assessments of fire-damaged buildings. More recently, Dick was also a member of the FEMA/ASCE-SEI World Trade Center Building Performance Study Team.

From 1965-1986, Dick was the Chief Fire Protection Engineer for the American Iron and Steel Institute (AISI) in Washington, DC. During those years, he directed a multi-million dollar industry research program, developed and published design aids and computer software, and published engineering procedures for the fire design of steel buildings. His leadership role in advancing steel fire design for the good of the general public and industry is well known.

Throughout his illustrious career, Dick authored numerous technical papers and gave many presentations. As befitting someone of his stature, he was an active member of many professional organizations, societies, and committees, including the AISC Fire Safety Engineering Committee, National Fire Protection Association (NFPA), ASTM E5, Society of Fire Protection Engineers (SFPE), and ACI.

Dick was liked and respected for his vast knowledge and experience in fire protection engineering. His many lifelong contributions to the profession and practice of fire protection engineering are hereby acknowledged with great appreciation. His life's work provides a significant basis for the future work to be continued by his many colleagues.

# TABLE OF CONTENTS

**INTRODUCTION**.....vii

**Section 1.**  
GENERAL FIRE SCIENCE.....1

**Section 2.**  
FIRE RESISTANCE OF STEEL SYSTEMS.....7

**Section 3.**  
U.S. BUILDING CODE CRITERIA AND USE OF  
PRESCRIPTIVE FIRE RESISTANCE RATINGS .....17

**Section 4.**  
THE ASTM E119 STANDARD FIRE TEST.....23

**Section 5.**  
APPLICATION OF ASTM E119 FIRE RATINGS .....29

**Section 6.**  
STRENGTH AND REPARABILITY OF STEEL AFTER A FIRE .....33

**Section 7.**  
PAST BUILDING FIRE INCIDENTS AND CASUALTIES .....37

**Section 8.**  
SPECIAL STEEL FIRE RESISTANCE ISSUES AND FUTURE NEEDS .....43

**REFERENCES** .....49

# INTRODUCTION

Steel-framed structures in high-rise office buildings have historically survived fire exposures extremely well. Two examples of severe fires are the 1988 First Interstate Bank fire in Los Angeles and the 1991 One Meridian Plaza fire in Philadelphia; the details of these and other significant building fires are given in Section 7.2. In fact, there has been no recorded structural failure of a protected high-rise steel frame building solely due to fire.

FEMA 403 (FEMA, 2002) documents the performance of the World Trade Center (WTC) towers and surrounding structures in the malicious terrorist attacks of September 11, 2001, and forms the basis for the continuing work of the National Institute of Standards and Technology (NIST). It is important to distinguish "normal" building fires from this extraordinary WTC experience, which involved the combination of severe structural damage, destruction of fire protection, suppression and egress systems, and simultaneous severe fires on several floors. The September 11 tragedy and the breadth of commonly asked questions about building fires, fire safety, and fire resistance have provided the main impetus to this compilation of available information. It is intended to serve as an objective general reference and introductory primer, in a convenient question and answer format, for the benefit of engineers, architects, building code officials, owners, developers, construction managers, general contractors and the general public and others with interest in the subject. More detailed information, data, analysis or design criteria are available in the cited references. This compilation is organized as follows:

- Section 1.** General Fire Science
  - Section 2.** Fire Resistance of Steel Systems
  - Section 3.** U.S. Building Code Criteria and Use of Prescriptive Fire Resistance Ratings
  - Section 4.** The ASTM E119 Standard Fire Test
  - Section 5.** Application of ASTM E119 Fire Ratings
  - Section 6.** Strength and Reparability of Steel After a Fire
  - Section 7.** Past Building Fire Incidents and Casualties
  - Section 8.** Special Steel Fire Resistance Issues and Future Needs
- References**

The American Institute of Steel Construction, Inc. (AISC) provided funding for this compilation. The authors also gratefully acknowledge the review of this document by

William B. Bourne  
Chairman

Harry W. Martin  
Vice Chairman

Kathleen Almand  
Robert M. Berhinig  
Charles J. Carter  
David S. Collins  
Greg Deierlein  
Robert J. Dexter  
John J. Dowling  
Bruce Ellingwood  
Michael F. Engestrom  
Dave Frable  
John L. Gross  
Manny E. Herrera  
Socrates Ioannides  
Joseph M. Jardin  
Lawrence A. Kloiber  
Venkatesh K. R. Kodur  
Joel Kruppa

Barbara Lane  
David H. MacKinnon  
Shinju Matsushita  
Brian J. Meacham  
James A. Milke  
John L. Ruddy  
Larry K. Schilling  
Jean-Baptiste Schleich  
Paul E. Senseny  
Robert E. Solomon  
Ian R. Thomas  
Emile W.J. Troup  
Beth Tubbs  
Michael J. Tylk  
Sriramulu Vinnakota  
Robert D. Weber  
Robert J. Wills  
  
Farid Alfawakhiri  
Secretary

# Section 1

## GENERAL FIRE SCIENCE

### 1.1 What are the goals of fire design provisions and building code requirements?

The primary goal of fire protection in buildings is to preserve life safety. A secondary goal is to protect property and safeguard the environment. These goals are achieved by:

- Providing safe means of escape, or safe refuge, for the occupants in the event of a fire.
- Designing the building to limit the progress and spread of fire and smoke, and to minimize structural damage.

Smoke is by far the greatest direct cause of casualties and injuries during fires—approximately 75 percent of fire victims die from smoke inhalation (Gann, et al, 1994). These deaths can occur in areas remote from the fire itself due to smoke propagation throughout the building, which thereby contaminates other floors and rooms, as well as potential escape routes, such as stairwells and hallways.

Building codes include requirements for smoke barriers. The International Building Code (ICC, 2003), hereafter referred to as the IBC, defines a smoke barrier as “a continuous membrane, either vertical or horizontal, such as a wall, floor, or ceiling assembly, that is designed and constructed to restrict the movement of smoke.” Likewise, the National Fire Protection Association Building Code (NFPA, 2003), hereafter referred to as NFPA 5000, defines a smoke barrier as “a continuous membrane, or a membrane with discontinuities created by protected openings, where such membrane is designed and constructed to restrict the movement of smoke.” However, these general definitions do not provide a specific or quantitative measure, or standard, by which a smoke barrier can be rated.

### 1.2 What fire protection systems are commonly used in buildings?

Building fire protection systems include active components (see 1.3) and passive components (see 1.4). Building codes such as the IBC and NFPA 500 mandate the minimum fire protection requirements for buildings in the form of active and/or passive protection. In some specific cases, either active or passive systems are permitted to be used alone. In other cases, both active and passive systems are required. Building codes thereby provide a balanced approach, relying on one system or both as appropriate to ensure safety for the associated occupancies and exposures.

### 1.3 What are some examples of active fire protection systems?

Active fire protection systems are those that utilize automatic devices or human action to initiate countermeasures, such as to suppress the fire and/or alert occupants to the emergency for the purposes of building evacuation. Examples of active fire protection systems include:

- Automatic sprinkler systems.
- Smoke and fire detector and alarm systems.
- Water supply systems, hose cabinets, fire extinguishers.
- Systems and personnel involved in fire department response.

### 1.4 What are some examples of passive fire protection systems?

Passive fire protection systems are those that function without external activation. Examples of passive fire protection systems include:

- Building code limitations for the combustion characteristics of construction materials, finishes, internal furnishings and contents.
- Compartmentalized design, which includes horizontal and vertical fire and smoke barriers, fire doors and windows, fire stops, and fire dampers.
- Structural fire protection materials that prevent or delay the temperature rise in structural elements. For structural steel framing, these materials usually are spray-applied fire resistive materials (SFRM), gypsum board enclosures, or intumescent coatings.

### 1.5 How effective and reliable are automatic sprinkler systems?

Sprinkler systems have proven to be exceptionally effective and reliable when properly designed, installed and maintained. Their effectiveness in improving life safety is particularly noteworthy.

Strict regulations are in place in the U.S. for sprinkler system design, installation, inspection, testing and maintenance. The historical record of sprinkler system performance during conventional fires, the National Fire Protection

Association (NFPA) report states (Rohr, 2001), are summed up best as follows:

*“Sprinklers typically reduce chances of dying in a fire and the average property loss by one-half to two-thirds in any kind of property where they are used.”*

*“NFPA has no record of a fire killing more than two people in a completely sprinklered public assembly, educational, institutional or residential building where the system was working properly.”*

See 7.5 for further information.

### 1.6 What are the fundamental stages of a fire?

There are 4 fundamental stages in a natural fire. These stages are schematically illustrated in Figure 1.1.

The first stage is the incipient ignition phase, wherein heating of the potential fuel source(s) takes place. The second stage is the growth stage, which involves ignition with visible flaming combustion. As the fire grows and reaches sufficiently high temperatures—about 1,100 °F (600 °C)—it may become fully developed within the compartment and reach the so-called “flashover” condition (see 1.7), which generally marks the beginning of the third stage called the burning period. The temperatures and heat flux are so great within the fire compartment that all exposed surfaces are burning and the available ventilation will govern the rate of heat release. This most severe stage of the fire causes the greatest effects on the building elements. Eventually, the fuel for the fire in the given compartment becomes exhausted, and the fire will start to die out during the fourth stage called the decay period. The decay phase is generally begins when about 70 percent of the combustible materials in the compartment have burned.

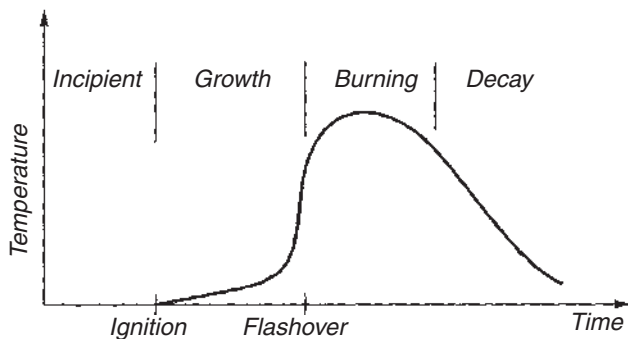

Fig. 1.1. Stages of Fire Development (Buchanan, 2001)

It can thus be seen that a fire in a specific compartment eventually self extinguishes. However, its spread to other compartments must be prevented or the fire can continue migrating both vertically and horizontally, repeating the entire cycle of fire ignition, growth, burning, and decay periods.

It is also obvious from the curve in Figure 1.1 that the most effective means for providing fire safety is either prevention of fire ignition altogether, or extinguishment of the fire during the early growth stage. Once a fire reaches the dangerous burning period, evacuation and fire department response become even more necessary. Adequate preparedness and awareness by the building management, its occupants, and the local fire departments for response to fire emergencies are imperative in order to minimize the consequences of fires.

### 1.7 What is “flashover”?

“Flashover” is the abrupt transition from relatively light burning of a small number of combustibles in the room, or a small portion of the room, to full-room involvement in fire. Room fire flashover is in essence a state in which all of the combustible contents of the room experience a nearly simultaneous ignition, with very visible flaming throughout. Fortunately, most fires never reach flashover, either because they are successfully detected and extinguished, or because the necessary ambient conditions within the compartment are lacking. Some fires self extinguish due to insufficient air supply (ventilation), or due to inadequate presence of combustibles to continue the fire. Historical data indicates that flashover will not occur in premises with properly designed, installed and functional automatic sprinkler systems.

Whether or not flashover occurs during an uncontrolled fire, and the time required to reach the flashover stage, depends on many factors, including:

- The amount and properties of combustible contents.
- The volume of the compartment.
- Ventilation conditions

In larger compartments, if flashover occurs at all, the time to reach this condition will be longer. In well-ventilated larger premises, such as open-deck parking structures, large hotel atriums, and sprawling warehouses and retail stores, “flashover” probably cannot occur.

### 1.8 How does a natural fire differ from a standard fire used in laboratory tests to obtain fire ratings for structural assemblies?

ASTM E119 *Standard Test Method for Fire Tests of Building Construction and Materials* provides the basis for the

test fire used in establishing fire ratings of structural building elements in the US. UL 263 *Fire Tests of Building Construction and Materials* and NFPA 251 *Standard Methods of Fire Endurance of Building Construction and Materials* are similar documents. The controlled ASTM E119 standard fire is fast starting, hot, and rising with an equivalent burning temperature of 1,000 °F (538 °C) after only 5 minutes. Internationally, the ISO 834 standard fire has similar characteristics. See Sections 2 and 4 for further information on ASTM E119.

A natural fire, when uncontrolled, has distinct stages of growth, burning, and most notably, decay (see 1.6). In contrast, the ASTM E119 standard fire has no decay branch, but specifies ever-increasing furnace compartment temperatures with time that can reach 2,300 °F (1,260 °C) at 8 hours, if testing were to reach this duration. Normally, ASTM E119 fire tests are not conducted for more than 3 to 4 hours.

The ASTM E119 standard fire thus represents the most intense burning stage of a real fire, but with inexhaustible and increasing fuel supply provided by the furnace. A natural fire eventually consumes its combustibles in a time that is dependent upon the initial quantity and type of fire load (combustibles, see 1.11) and ventilation present in the compartment. Hence, the actual fire load and ventilation present in the room will determine the nature, intensity, and duration of a real fire. Uncontrolled, well-ventilated fires burn faster and reach higher temperatures than poorly ventilated fires, but they have a shorter duration for the same fuel. This is illustrated in Figure 1.2, in which  $F_v$  is a ventilation factor.

In Figure 1.3, the ASTM E119 standard time-temperature curve is superimposed on representative real fire curves under burning conditions for various fuel loads and a constant ventilation factor. The maximum fire temperature, its

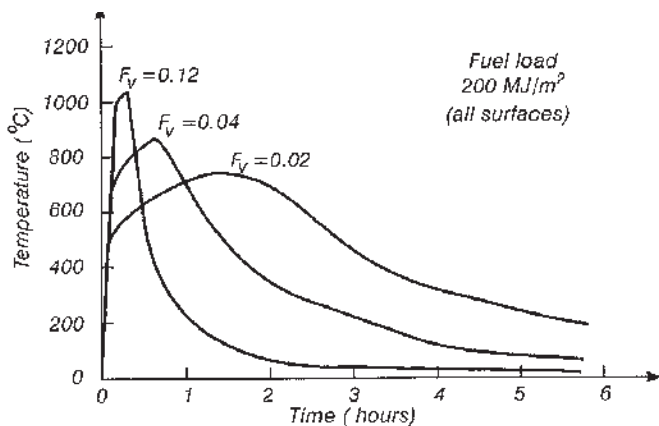

Fig. 1.2. Real Time-Temperature Curves for Different Ventilation Factors  $F_v$  with a Constant Fuel Load (Buchanan, 2001)

decay phase, and fire time duration are significantly affected by the fuel content, and are quite different from the standard time-temperature curve. As expected, higher fuel loads cause longer and hotter fires under uncontrolled conditions. The standard fire time-temperature curve between 1 to 4 hours provides a reasonably good estimate of the maximum room temperature that will be encountered in a real conventional fire in many cases. However, in real uncontrolled fires, these high temperatures most likely occur over only a relatively short time interval.

For faster-starting and hotter fires, such as those that occur from petrochemicals or other hazardous materials, a standard fire exposure more severe than that given in ASTM E119 may be more appropriate. ASTM E1529 (UL 1709) *Standard Test Method for Determining Effects of Large Hydrocarbon Pool Fires on Structural Members and Assemblies* defines such a standard fire exposure that reaches and remains at about 2,000 °F (1,100 °C) after 5 minutes.

Mathematical representations of the ASTM E119 standard fire time-temperature curves and a variety of real fire time-temperature curves can be made for analytical purposes. Various such formulations can be found in the literature listed in Section 8.2.

### 1.9 At what temperature and for how long does a normal fire burn?

The maximum temperature and duration of a fire in a building compartment depends on several variables, including

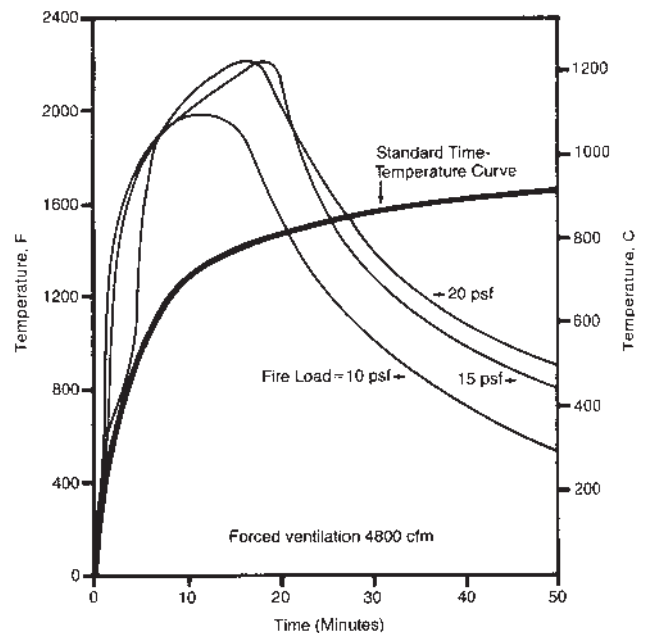

Fig. 1.3. ASTM E119 Standard Fire and Real Fire Time-Temperature Curves (AISI, 1981)



**Table 1.1 Relationships Between Fire Load (Wood Equivalent) and Standard Fire Endurance Time (Ingberg, 1928) (AISI, 1981)**

Average Fire Load, psf	Average Fire Load, kg/m <sup>2</sup>	Equivalent Fire Endurance (hours)
5	24.4	½
7 ½	36.6	¾
10	48.8	1
15	73.2	1 ½
20	97.6	2
30	146.5	3
40	195.3	4 ½
50	244.1	6
60	292.9	7 ½

the amount and configuration of available combustibles, ventilation conditions, properties of the compartment enclosure, and weather conditions. In a typical fire, such as in an office, residential or retail occupancy, the maximum temperature of a fully developed fire will likely not exceed 1,500 °F (815 °C), though it could range up to a peak of 2,000 °F (1,093 °C) under more severe conditions. The maximum temperature will typically last for only 10 to 20 minutes during the peak of its burning period within the compartment. Consequently, the average real gas temperature within the fire compartment will not reach its maximum level (see Figure 1.3) over the fire duration for any exposure.

**1.10 Given these differences between real and standard fires, why are the common fire ratings based on the standard fire?**

There are unavoidable variations and uncertainties in real building fires. No two real fires will have the same time-temperature curve. A standard fire test and associated time-temperature curve, such as that prescribed in ASTM E119, is used to provide a simple and constant comparative baseline for the relative assessment of fire endurance times for different structural members and assemblies.

No standard fire is a predictor of actual fire resistance times during a real fire, though the early work by Ingberg (1928) showed an approximate correlation between the fire severity of a standard fire with a real fire by comparing and equilibrating the areas under the respective time-temperature curves. Note that the shape of the building compartment, the type of combustible materials, their rate of heat release and the ventilation conditions are not explicitly considered in this approximate correlation. Under these assumptions and with noncombustible construction, Ingberg developed the equivalent fire severity hypothesis, which relates the average fire loads on a wood equivalent basis (see 1.11) in a given compartment area to a fire endurance time in a standard fire. These relationships are illustrated in Table 1.1.

Given a wood-equivalent fire load of 10 pounds per square foot (psf) in a room with a 1-hour fire-resistive construction rating, it should be able to survive a complete fire burnout of the room without structural collapse and prevent fire propagation beyond the room of fire origin. Such general equivalencies still form the underlying rationale behind the use of standard fire resistance ratings in today's building codes. Despite the inherent assumptions and limitations compared to actual conditions, the use of a standard fire continues to offer the best approach for assessment of the comparative fire resistance of structural assemblies.

**1.11 What is a fire load and what is the range of typical fire loads in buildings?**

The fire load is the amount of combustible material in the compartment. Traditionally, this has been expressed in terms of the wood-equivalent weight of combustible building contents per unit building floor area (that is, in pounds per square foot or psf). The actual weight of combustible contents is adjusted to the so-called wood-equivalent weight based on the estimated potential heat of contents normalized to the potential heat of wood. Alternatively, the more modern representation of fire load is in terms of the potential heat of building contents per unit building floor area, e.g. Btu/ft<sup>2</sup> (or MJ/m<sup>2</sup> in metric units).

The available fuel load is determined by the room size and the nature, amount and arrangement of its combustible contents. Fire loads should normally account for all combustible building contents, including furnishings, equipment, and combustible construction components. In reality, the majority of the fire load in a building results from additional furnishing and contents being introduced after the construction is completed, which is sometimes not adequately considered in evaluating the risk to fire safety.

The combustibles can be characterized by several properties. Primarily its potential heat, net calorific value, or heat

of combustion is used. These are expressed in terms of heat energy per unit of weight (or mass), e.g. Btu/lb (or MJ/kg in metric units). Wood is often used as an ordinary combustible benchmark, having approximately 7,000 to 8,000 Btu/lb (16 to 18 MJ/kg). Plastics contain more heat of combustion: 10,000 to 17,000 Btu/lb (24 to 40 MJ/kg). Liquid petroleum products range within 12,000 to 20,000 Btu/lb (27 to 46 MJ/kg). Multiplication of this property by the expected combustible weight (mass) distribution in the space gives the total potential heat energy that could be released during a fire event.

A conventional office building fire involving combustibles such as wood and plastics with potential heat energy of 7,000 to 17,000 Btu/lb (16 to 40 MJ/kg) and a typical fire load density for an office space of 6 psf (30 kg/m<sup>2</sup>), would create a total potential heat energy of 42,000 to 102,000 Btu/ft<sup>2</sup> (about 480 to 1,200 MJ/m<sup>2</sup>) per unit floor area. A storage room, or a library, might double this fire load. Fire engineering textbooks and handbooks (SFPE, 2002) contain much more specific information and burning properties on these and other combustible materials.

### 1.12 How fast does a conventional fire spread?

If ignition can be prevented or the fire detected and suppressed during its growth or early burning stage, it can be effectively contained within a matter of minutes and will not spread further. For this reason, fire prevention and early suppression are the best solutions to fire safety.

Automatic sprinklers have been found to be very effective for putting out most fires before they can reach flashover, or before they grow to an uncontrolled state during the burning phase. If a fire does progress to flashover or an otherwise uncontrollable burning stage, the rate at which it spreads and grows in a building depends on many other factors that are site and time specific to the particular event. These include:

- Combustion properties of the construction materials and building contents.
- Ventilation conditions.
- Room geometry and configuration.
- Timeliness of detection.
- Effectiveness of fire suppression response by the occupants and/or the local fire department.
- Availability and effectiveness of automatic fire suppression systems.
- Availability and effectiveness of fire barriers.

As witnessed in several past building fires, if fire ignition and growth is not prevented or suppressed within the compartment of fire origin, it can spread quickly to multiple rooms and floors. Any unusual circumstances that would facilitate fire initiation and propagation, such as arson, terrorist acts, illegal presence of fuels and combustibles, clearly accelerate and increase the fire dangers compared to those expected in an accidental conventional fire.

### 1.13 How does the heat transfer from the fire to the surrounding structure occur?

Ultimately, it is not just the room fire temperature that controls structural response, but the heat input and corresponding temperature rise that occurs in the structural material. In general, heat transfer can occur in 3 ways: conduction, convection, and radiation.

Conduction is heat transfer through solid materials, and involves the material properties of density, specific heat, and thermal conductivity. Convection is heat transfer through fluids, either gases or liquids, which is a linear function of the gas temperatures. Radiation is the transfer of heat energy by electromagnetic waves, which depends on the gas temperature raised to the fourth power.

For protected structural steel, the temperature increase due to fire results primarily from radiation to the fire protection material and conduction through the protection, with inclusion of the appropriate insulating properties and thickness of the material. Therefore, the temperatures in protected steel will be continually less than those of the fire during the heating phase. How much less depends on the thickness and nature of the insulating material, as well as the size and weight of the steel member itself. Of equal importance are the thermo-physical properties of the steel fire protection material, such as cohesion and adhesion during the fire event.

For unprotected (bare) steel, temperatures are affected both by convection and radiation. The pertinent heat transfer equations, thermal parameters and properties are available in the literature (SFPE, 2002). In this case, the temperatures of the bare steel will eventually reach the same levels as that of the fire compartment. The unprotected steel temperatures are a function of the nature of the fire exposure and the weight and heated perimeter of the steel shape. Hence, the time for the steel to reach temperature equilibrium with its surroundings will depend on these conditions. Once steel temperature equivalence with the fire is reached, it will be essentially maintained for the duration of the fire. If the primary heating of the steel is due to its direct exposure to flame impingement, or line-of-sight radiant heat, shielding of the steel is one effective way to reduce its temperature increase.

### **1.14 What are “thermal mass” and “thermal inertia”?**

“Thermal mass” is sometimes used to refer to effective specific heat or heat capacity. Effective specific heat, usually expressed in Btu/[lb °F] (or J/[kg °C] in metric units), is the amount of energy, per unit mass or weight of material, required to raise the temperature of the material by one temperature unit. Similarly, effective heat capacity, which is sometimes called volume-specific heat, expressed in Btu/[ft<sup>3</sup> °F] (or J/[m<sup>3</sup> °C] in metric units) is the amount of energy, per unit volume of material, required to raise the temperature of the material by one temperature unit. This derived property is simply the product of the material specific heat and its density.

Another derived property is the “thermal inertia”, which is the product of the material thermal conductivity, density, and specific heat, with dimensional units of Btu<sup>2</sup>/[ft<sup>4</sup> °F<sup>2</sup>h] (or W<sup>2</sup>s/[m<sup>4</sup> °C<sup>2</sup>] in metric units). Materials with a high thermal inertia are more desirable, since they will not ignite or heat up quickly.

For most construction materials, specific heat, heat capacity and thermal conductivity values are all temperature dependent, as is the derived property of thermal inertia. These thermal property values change significantly in the temperature range associated with building fires, which is 100 to 2,000 °F (40 to 1,100 °C), because most materials undergo physiochemical changes at elevated temperatures. The thermal properties are also sensitive to the testing method used and the rate of temperature rise. Therefore, it is common to find different values of material properties for the same material in different literature sources.

### **1.15 What is a “heat sink”?**

A “heat sink” is anything that can absorb large amounts of heat through physical and/or chemical processes. Usually, materials containing large amounts of chemically combined water in their structure, such as gypsum or concrete, absorb significant amounts of heat due to the energy consumed in the water evaporation process. Materials with high thermal conductivity and high effective heat capacity will also act as heat sinks.

### **1.16 Where can one find the thermal conductivity or thermal resistance values of the building and fire protection materials?**

Information on the thermo-mechanical properties at elevated temperatures of the common construction materials (steel, concrete, masonry, and wood) and fire protection materials (spray-applied coatings, gypsum board, etc.) is scattered. For some materials, it is not available at all. One good general source for the thermo-mechanical properties of various types of building materials and combustibles is SFPE (2002). Some further information on the properties of steel at elevated temperatures is given in Section 2.

## Section 2

# FIRE RESISTANCE OF STEEL SYSTEMS

### 2.1 What does the term “fire resistant” mean?

Fire resistance is the duration during which a structural assembly or element exhibits adequate structural integrity, stability and temperature transmission, usually as specified by a given standard test method. Thus, a structural assembly or element with a fire resistance rating is one that has been tested or evaluated to determine its resistance to a standard fire, such as that in ASTM E119. This fire rating is usually expressed as a number of hours and describes the ability of the assembly or element to withstand fire in a relative sense compared with other assemblies or elements. There are testing protocols for the evaluation of the performance of beams, columns, walls, floors, and roofs, and these elements commonly are determined to have fire resistance ratings from 1 to 4 hours. A prototype of an actual construction assembly is tested using these protocols, prescribed limiting temperatures, and other criteria to determine the hourly rating, i.e. the fire resistance. For further information, see Section 2.6.

### 2.2 What does the term “fire protected” mean?

Fire protection, in a general sense, refers to everything associated with providing fire safety, including sprinklers, egress, separations, fire detectors and alarms, and fire resistance. With regard to steel and other building materials, fire protection also refers more narrowly to the insulative materials applied to the structural members. For further information, see Section 1.2.

### 2.3 Do the terms “fire-resistant” and “fire-protected” mean “fireproof”?

No, the term “fireproof” is commonly used, but an unfortunate colloquial misnomer - no building material is actually fireproof. All construction materials suffer degradation of their properties and damage at elevated temperatures. Materials that are designed to have some substantial level of fire resistance often improperly use the term “fireproof” to describe their end objective, or the process by which that measure is accomplished. Indeed the misnomer extends to the use of the term “fireproofing” to describe the spray-applied fire-resistive materials that get applied to steel. This more technically correct but seldom used term can be abbreviated SFRM.

### 2.4 How is a fire resistance rating developed?

ASTM E119 has been the basic and traditional standard for fire-resistance testing in the US since 1918. UL 263 and NFPA 251 are similar, as is the international standard ISO 834. ASTM E119 is applicable to individual beams, columns, floors, walls, and other building elements of any material. Each assembly or element is subjected to a standard fire with a time-temperature curve as shown previously in Figure 1.3. In applications involving hydrocarbon pool fires, ASTM E1529 or its equivalent UL 1709 is used.

These documents establish the specific testing requirements and acceptance criteria used to establish fire resistance ratings. They define the laboratory equipment needed to accommodate the minimum required specimen sizes within a controlled furnace chamber, the instrumentation needed to measure temperatures in the furnace and the test specimen, and the means to apply superimposed loading to the specimen, as needed. There are several experimental facilities in the US that conduct standard fire resistance tests, including Underwriters Laboratories, Inc. (UL), FM Global, Southwest Research Institute, and Omega Point Laboratories. The fire resistance ratings produced by these and similar facilities are commonly accepted by US building code authorities based upon their publication in the literature, such as the UL Fire Resistance Directory.

The maximum fire test frame will vary in size among the individual laboratory facilities. Consequently, the fire specimen dimensions are quite limited relative to actual construction. For example, UL has the capability to test up to a 14 ft by 17 ft specimens for beams, floor assemblies, and roof assemblies, up to a 10 ft by 10 ft specimens for walls, and up to 9 ft high specimens for columns. Thus, the typical fire test is made of an isolated or smaller-scale prototype assembly or element, not necessarily full-scale replications of actual construction. ASTM E119 is therefore strictly a comparative standardized test of selected structural and product features.

Usually, the fire test duration closely matches the desired fire rating (e.g., 1, 2, 3 or 4 hours). ASTM E119 prescribes ever-increasing temperatures with time duration; 1,700 °F (927 °C) at 1 hour increasing to 2,000 °F (1,093 °C) at 4 hours. This standard fire exposure attempts to represent a fully developed fire exposure with an implied endless fuel supply and adequate ventilation for intense fire continuation in a given location. In contrast, a real fire reaches a decay period (see Section 1.6) and eventual burnout. Approximate time equivalencies can be established between the standard

and natural fire exposures for some conditions. The resulting fire-resistance rating is expressed as the interval of hours that the assembly or element was able to withstand exposure to the standard fire before a limiting criterion was reached. Examples of the limiting criteria include:

- The assembly or element can no longer support the applied load.
- Excessive temperature rise in steel specimens tested without load.
- Excessive temperature rise on the unexposed surface of floor, roof or wall specimens.
- Passage of gases (through floor, roof or wall specimens) hot enough to ignite cotton waste pads applied to the unexposed surface.

The ASTM E119 standard thereby:

- Evaluates the relative heat transmission and structural integrity characteristics of specimens under the standard fire exposure.
- For specimens tested without load, establishes critical temperature limits, which are conservative estimates based on the maximum allowed reduction in the strength of structural members at elevated temperatures.
- Explicitly assesses the adequacy of a properly applied fire protection material or system, including the preclusion of vulnerabilities to deterioration, delaminating and detachment from the steel specimen.

See also Section 4.

## **2.5 What are the assumptions of ASTM E119 fire resistance ratings?**

There are several assumptions that form the basis of ASTM E119 fire resistance ratings:

- The basis of the rating uses a standard time-temperature curve that differs from the time-temperature curve for a real uncontrolled fire, as described in Section 1.8.
- The standard fire assumes a uniform temperature distribution through the entire fire compartment. In actual fires, the temperature distribution is not really uniform.
- Hot gas pressures in real fire compartments could be different from test furnace pressure.
- The loading intensity and pattern applied to the specimen during the test are not intended to account for the actual loading conditions in a real building during a real fire.

- The loading intensity in the test is based upon the maximum calculated strength, whereas members are not likely to be supporting their full design load in a real fire.
- The test and real applications will differ in specimen boundary conditions, assembly and component size.
- ASTM E119 does not address smoke generation and propagation effects or their effects on life safety, though other standards do specifically address combustibility and smoke.
- Published fire resistance ratings are given in terms of whole hours of time during which the specimen met the acceptance criteria, not necessarily the full recorded fire endurance times. That is, two rated assemblies, one with an actual fire endurance of 121 minutes and another with 179 minutes qualify for the same 2-hour rating.
- Aside from the basic experimental outputs needed to determine the ASTM E119 rating, other potentially useful test results are not normally collected, such as the thermo-physical property variations at high temperatures of the construction and fire protection materials.

Regardless of the aforementioned assumptions and limitations, ASTM E119 has historically served as a useful and conservative benchmark measure of the relative fire resistance of different building elements and materials.

## **2.6 Are structural steel frames and members fire resistant? What is the nature of high temperature effects on steel and other building materials?**

Yes, steel is fire resistant. Steel is a durable noncombustible material with many excellent structural properties. The mechanical properties of steel deteriorate under elevated temperatures are described in Section 2.7. Consequently, steel must be properly designed and constructed using an appropriate system or assembly. Modern building codes contain prescriptive criteria for determining when and what requirements apply for the various types of construction, heights, areas, and occupancies. Under limited conditions, unprotected steel is permitted for certain types of hazard, occupancy, heights, and areas, such as some low-rise buildings, sports stadia and open-deck parking garages. When required, steel members can be insulated from fire effects through various means, including spray-applied fire-resistant materials, intumescent coatings, gypsum-board enclosure, and concrete encasement or filling.

Prolonged heating will adversely affect all building materials, with visible damage and distortions always occurring under prolonged elevated temperatures. Deflections of structural members during long and hot fires can reach many inches, or several feet, which is an order of magnitude

greater than the small elastic deflections that are normally contemplated in structural design. Local buckling and twisting can also be experienced under high temperatures. Concrete spalls when exposed to elevated temperature, thereby exposing its reinforcing steel to the direct effects of the fire. Concrete strength is also degraded at elevated temperatures.

**2.7 How much does the steel strength and stiffness degrade at higher temperatures? Will steel melt in a fire?**

At higher temperatures, both the yield strength and tensile strength of steel decrease, as does the modulus of elasticity. Curves showing the strength and stiffness reductions in steel with increasing temperature can be found in ASCE (1992), SFPE (2002) and other references given in Section 8.2. In general, steel retains strength and stiffness approximately equal to 50 percent of its strength and stiffness at ambient conditions at a temperature of 1,100 °F (593 °C). This is comparable to the strength and stiffness reductions for ordinary concrete. At 1,300 °F (704 °C), steel retains about 20 percent strength and stiffness. A near-total depletion of strength occurs at approximately 2,200 °F (1,204 °C).

Usually, it is convenient to represent the variation of yield strength as a function of temperature and as a fraction relative to the steel strength at ambient temperature, as shown in Figure 2.1 (ECCS, 2001). The same steel strength curves and values apply to both uniaxial tension and compression. Similarly, the variation of modulus of elasticity is shown in Figure 2.2.

Note that the values in Figure 2.1 were developed from small test material coupons, which were uniformly heated throughout the full cross section of the coupon. The tem-

peratures shown are those in the steel specimen and are not necessarily identical to the fire temperature (see Section 1.13). There are also many common cases in which this uniform heating of the steel member will not occur during a fire.

For example, in a composite floor the protected steel beam will be hottest at the bottom flange, which is closest to the fire, and coolest at its top flange, which is in contact with the concrete and floor deck. For this fire exposure, while the beam bottom flange may have reached sufficiently high temperatures to lose much of its strength and stiffness, the upper portions of the beam may be well below the critical temperatures for steel. In such cases, the top flange can be as much as 750 °F (400 °C) cooler than the bottom flange in a 2-hour ASTM E119 test.

These temperature reductions are temporary as long as the steel temperatures do not exceed about 1,300 °F (700 °C) for more than about 20 minutes. Such fire-damaged steel, though likely deformed, will regain its pre-fire properties at ambient conditions. However, higher temperatures and longer exposures will likely result in annealing and a reduction in yield strength. Caution should also be exercised in extrapolating these properties of the commonly used structural steels to heat-treated steels, cables and similar products with yield strengths in excess of 70 ksi (500 MPa); these products will likely require evaluation to determine the effects of high-temperature exposure.

It can be said with confidence that structural steel does not melt in building fires, although such possibility is theoretically possible for certain conditions (comparable to melting furnace conditions). Building fires simply do not generate steel melting temperatures that are around 2,700 °F (1,500 °C).

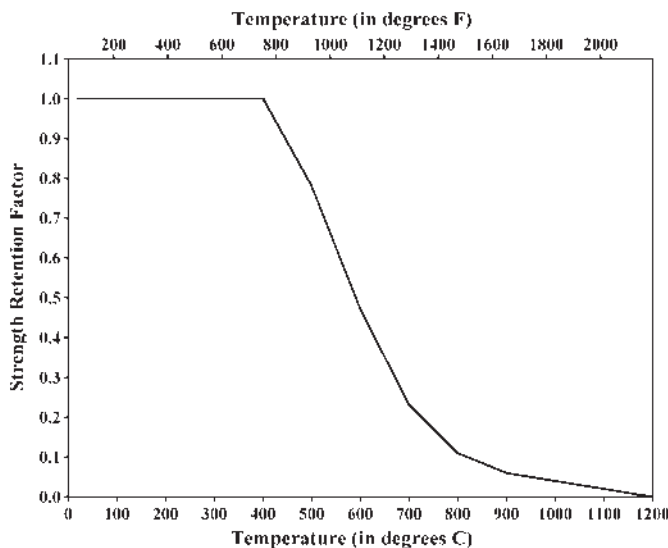

Fig. 2.1. Yield Strength Retention Factors for Structural Steel at Elevated Temperatures

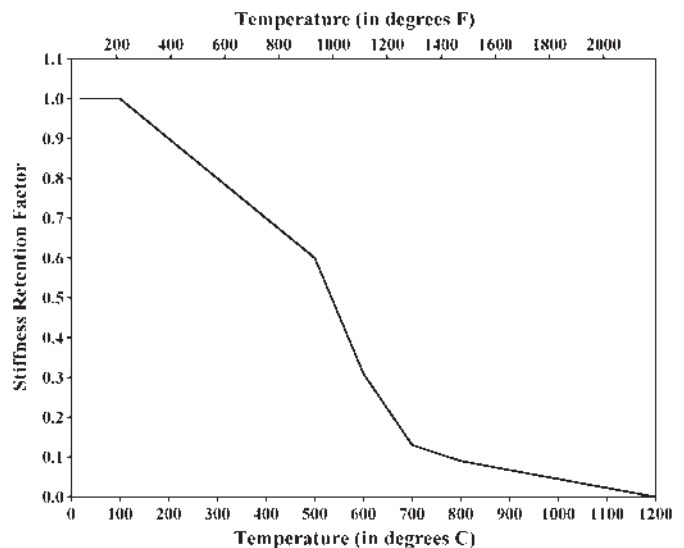

Fig. 2.2. Modulus of Elasticity Retention Factors for Structural Steel at Elevated Temperatures

## 2.8 Does the grade of steel used affect its response to a fire?

Common structural steel grades in the US generally exhibit similar deterioration of mechanical and thermal properties at elevated temperatures. The empirical scatter in these steel property variations is relatively minor compared to other uncertainties in fire design. Thus, the curves presented in Section 2.7 are adequate for all grades of steel.

Recently, there has been a strong effort to introduce a “fire resistant” steel grade developed in Japan. This steel has improved strength retention ratios at elevated temperatures, though similar variations in modulus of elasticity. This steel has not been widely used in the US.

## 2.9 How do fire protection materials function to protect steel in a fire?

Steel fire protection is achieved through one or more of the following thermodynamic mechanisms:

- Low thermal conductivity.
- High effective heat capacity.
- Heat-absorbing chemical reaction, such as endothermic decomposition or pyrolysis.
- Heat-absorbing physical reaction, such as transpiration, evaporation, sublimation, or ablation.
- Intumescence, which is the formation of a thick foam char upon heating.
- Radiation or reflection.

The common steel fire protection materials that provide one or more of these mechanisms function generally in one of three ways:

- Purely insulating—these are spray-applied fire resistive materials, such as mineral fiber and expanded aggregate coatings, such as vermiculite and perlite. UL has recently started referring to all the spray-applied fire protection coatings generically as “spray-applied fire resistive materials” (SFRM), unless they are of the mastic or intumescent type. As a result, it may now be difficult to immediately distinguish between the light and medium density, fibrous material mixed with water at the application nozzle and the cementitious materials mixed in a hopper and transported wet to the application nozzle.
- Energy absorbing—these are most commonly gypsum-based or concrete-based products, each of which release water of crystallization when exposed to high temperatures. The fire endurance time of concrete is increased by approximately 3 percent for each percent of entrapped

water (ASCE, 1992). Although gypsum is superior in this regard, concrete is a more durable material. Magnesium oxychloride cements are also in this category and contain up to 2.5 times the amount of water as gypsum.

- Intumescent—applied as paint, these coating systems expand upon exposure to high temperatures, forming an insulating layer. They are traditionally more expensive but provide many benefits, including lighter weight per surface area protected, durability, aesthetic acceptance for exposed steel, and good adhesion. They are available as both water-based and solvent-based products. These products must have adequate room to expand when exposed to the fire.

Fire protection materials could be classified as organic or inorganic depending on chemistry of their major components. Therefore, SFRM are often referred to as inorganic systems, while intumescent coatings are often referred to organic systems.

## 2.10 What is the composition of spray-applied fire-resistive materials (SFRM)?

Most SFRM either utilize mineral fiber or cementitious materials to insulate steel from the heat of a fire. Mineral fiber and vermiculite acoustical plaster on metal lath are two of the frequently used SFRM for on steel columns, beams and joists. These popular commercial products have proprietary formulations and, therefore, it is imperative to closely follow the manufacturer's recommendations for mixing and application

The mineral fiber mixture combines the fibers, mineral binders, air and water. It is a limited combustible material and a poor conductor of heat. Mineral fiber fire protection material is spray-applied with specifically designed equipment which feeds the dry mixture of mineral fibers and various binding agents to a spray nozzle, where water is added to the mixture as it is sprayed on the surface to be protected. In the final cured form, the mineral fiber coating is usually lightweight, essentially non-combustible, chemically inert and a poor conductor of heat.

Cementitious SFRM are composed of a binder material mixed with aggregates. Various additives and foaming agents are also often mixed in. The common binders are calcined gypsum and Portland cement. Some formulations use magnesium oxychloride, magnesium oxysulfate, calcium aluminate, calcium phosphate, or ammonium sulfate. The common aggregates are vermiculite and perlite. Some manufacturers have substituted polystyrene beads for the vermiculite aggregate. The frequently used vermiculite acoustical plaster is a cementitious product composed of gypsum binder and perlite or vermiculite lightweight aggregates.

All SFRM products are required to be, and have been, free of asbestos since the early 1970s.

### 2.11 What are some common fire protection products and trade names?

Low-density inorganic systems, such as the mineral fiber Blaze-Shield II and the cementitious Monokote MK-6 SFRM products, have densities on the order of 15 lbs/ft<sup>3</sup> (240 kg/m<sup>3</sup>) and are highly efficient and lightweight. They can be easily removed from the steel, such as by trades to mount hangers, clamps, electrical boxes, steel conduit, ductwork, and similar attachments. This ease of removal is also a concern if used in a location where activities might accidentally damage the coating. Low density products are also generally not intended for outdoor weather conditions.

Medium-density inorganic systems, such as Duraspray and Pyrocrete-LD, have densities ranging from 20 to 27 lbs/ft<sup>3</sup> (320 to 430 kg/m<sup>3</sup>). Both of these products contain magnesium oxychloride (see Section 2.9). Medium-density inorganic systems have excellent fire resistance and serviceability.

There are also high-density inorganic systems:

- Ordinary concrete, which has a density of 100 lbs/ft<sup>3</sup> (1600 kg/m<sup>3</sup>) for lightweight concrete and 150 lbs/ft<sup>3</sup> (2400 kg/m<sup>3</sup>) for normal-weight concrete, is more durable, but adds weight and cost and is harder to modify in renovation work.
- Pyrok HD, Carbolite Type 40, Fendolite MII, Z-146, Albi-crete, Pyrocrete and Mandoseal products, which have densities ranging from 40 to 80 lbs/ft<sup>3</sup> (640 to 1280 kg/m<sup>3</sup>), each contain some component that enhances its fire protective performance. For example, Carbolite products generally contain magnesium oxychloride (see Section 2.9), while Mandoseal is a vermiculite-based cementitious system.

Organic systems, also known as intumescent and mastic systems, such as Nullifire, Firefilm, Albi Clad, Sprayfilm, Thermo-Lag, and many others, are esthetically appealing and relatively thin coating systems. These products function by means of a complex series of reactions involving intumescence, sublimation, ablation, and/or heat-absorbing chemical and physical reactions. Some of these organic systems require reinforcement at the flange tips to maintain the expanded insulation in-place under fire exposure.

The suitability of a fire protection product for any specific application depends on several factors including the required fire resistance rating, expected service conditions (exposure to weathering effects, vibration, accidental impact, etc), compatibility with corrosion protection requirements (if any), esthetics and economy considerations. The manufacturers' specifications should be closely

consulted for the range and limits of their product applications.

### 2.12 Besides SFRM and intumescent products, what other materials/methods can be used to protect steel from fires?

The alternatives to SFRM and intumescent products include the following:

- Concrete or masonry encasement, today more of a historic approach to steel fire protection, is sometimes used when construction details involve the placement of concrete or the construction of masonry elements.
- Filling tubular steel structures columns with concrete.
- Metal lath and plaster.
- Rated suspended ceilings (for floor-ceiling and roof-ceiling assemblies).
- Enclosure in gypsum board products, mineral board products, or ceramic wool wraps.
- Reflective shielding with steel sheets.

Some more exotic fire protection methods involve remotely located exterior columns, rain screens, and water-filled tubular structures. See Section 8.7.

### 2.13 If fire protection is damaged, what are the consequences?

The consequences of damage to fire protection vary with the amount of damage and the nature and severity of the fire. At the extreme, both the WTC towers and the Pentagon demonstrated that extensive structural damage and widespread destruction of fire protection (spray-applied materials on structural steel in the WTC towers; concrete cover on reinforcing steel in the Pentagon) can combine for catastrophe. Localized damage due to improper application, careless renovation, or inadequate long-term maintenance is not the same.

Normally, localized damage results in higher temperatures in a segment of a structural member but does not lead to overall member failure. This has been observed in many tests performed to the requirements in ASTM E119. Likewise, the 1996 large-scale Cardington fire tests in an eight-story steel framed building demonstrated excellent performance with totally unprotected interior floor systems with bare steel beams and deck (Newman et al, 2000 and Bailey, 2001).

Even if a member were to fail, the failure of a single beam or column in a fire is highly unlikely to lead to the progressive collapse of the entire building because of the



redundancies and reserve strength inherent in the typical steel building. Most structural steel framing is governed by serviceability design criteria that result in considerable reserve strength. Alternate load paths, contribution of non-structural components, and catenary action will all usually contribute to the stability of the entire structure in the event of localized damage or overload conditions.

#### **2.14 Can spray-applied fire protection materials (SFRM) be applied to painted or galvanized steel?**

Most SFRM is configured to adhere to bare steel, galvanized steel and painted steel. There are dimensional limits in many cases, so it is recommended that the SFRM manufacturer be consulted. The manufacturer can make recommendations for galvanized surfaces and usually maintains a list of primers and paints that have been tested in accordance with ASTM E736 *Standard Test Method for Cohesion/Adhesion of Sprayed Fire Resistive Materials Applied to Structural Members*. Such tests must indicate a minimum average bond strength of 80 percent and a minimum individual bond strength of 50 percent, compared to the bond strength of the same fire resistive material when applied to bare steel. If bond strength does not meet these requirements, a mechanical bond is normally obtained by wrapping the structural member with expanded metal lath weighing at least 1.7 lbs/yd<sup>2</sup> (0.92 kg/m<sup>2</sup>).

It should be noted that Section M3.1 of the AISC Specification has long stated that shop painting of steel for buildings is not required, unless specified in the contract documents. The corresponding Commentary elucidates further on this:

*“The surface condition of steel framing disclosed by the demolition of long-standing buildings has been found to be unchanged from the time of its erection, except at isolated spots where leakage may have occurred. Even in the presence of leakage, the shop coat is of minor influence.”*

Thus, when acceptable, it is usually better not to prime or paint steel, both to save the unnecessary costs and to eliminate the concern for SFRM adhesion. When left unpainted, the steel surface should be clean and free of oil, dirt, and loose mill scale. See also Section 2.17.

#### **2.15 What standards have relevance to the structural fire resistance of buildings?**

ASTM E119 is the most prominent and oldest standard, which specifies test procedures to establish fire resistance ratings for assemblies and elements in buildings. ASTM E1529 is similar but intended for fire testing in exposures subject to a hydrocarbon pool fire, such as in petrochemical

refineries and similar applications. Many other relevant ASTM standards also exist:

- ASTM E84 “Standard Test Method for Surface Burning Characteristics of Building Materials”
- ASTM E136 “Standard Test Method for Behavior of Materials in a Vertical Tube Furnace at 750 °C”
- ASTM E605 “Standard Test Methods for Thickness and Density of Sprayed Fire-Resistive Material Applied to Structural Members”
- ASTM E736 “Standard Test Method for Cohesion/Adhesion of Sprayed Fire-Resistive Materials Applied to Structural Members”
- ASTM E759 “Standard Test Method for Effect of Deflection on Sprayed Fire-Resistive Material Applied to Structural Members”
- ASTM E760 “Standard Test Method for Effect of Impact on Bonding of Sprayed Fire-Resistive Material Applied to Structural Members”
- ASTM E761 “Standard Test Method for Compressive Strength of Sprayed Fire-Resistive Material Applied to Structural Members”
- ASTM E859 “Standard Test Method for Air Erosion of Sprayed Fire-Resistive Materials Applied to Structural Members”
- ASTM E937 “Standard Test Method for Corrosion of Steel by Sprayed Fire-Resistive Material Applied to Structural Members”
- NFPA 259 “Test Method for Potential Heat of Building Materials”
- ASCE/SFPE 29-99 “Standard Calculation Methods for Structural Fire Protection”

#### **2.16 How do intumescent coating systems work?**

An intumescent coating, has a pre-fire appearance of a thick film of paint. When exposed to a fire, it chars, foams, and expands significantly in thickness. To retain this insulating layer, reinforcing is sometimes required at sharp corners, such as the flange tips of a wide-flange shape.

The intumescent mechanism involves the interaction of four types of compounds: a carbon source, an intumescent, a blowing agent, and a resin. The compounds of intumescent systems can generally be placed into four categories

- Inorganic acid, or material yielding an acid at temperatures of 212 to 570 °F (100 to 300 °C).
- Polyhydric material rich in carbon.
- Organic amine or amide, which act as a flowing agent.
- Halogenated material.

When the coating becomes sufficiently heated, the carbon source reacts with a dehydrating agent to form a char, which is simultaneously expanded by gases released from the blowing agent. The resin binder prevents the gases from escaping. This process results in an insulating layer that can be on the order of 100 times thicker than the original coating, thereby delaying temperature rise in the steel.

In many instances, the coating is actually a system of multiple coats with different properties and functions. For example, the base coat will be formulated to provide a strong bond to the steel substrate while the top coat will be formulated to provide a durable finished surface.

Intumescent products are usually the more costly choices relative to the other available fire protection alternatives.

### **2.17 Why are application procedures and inspection important with fire protection products?**

Each manufacturer of fire protection products uses a proprietary formulation in their products. These products are qualified through standard fire testing procedures that require the assembly to be built and protected in accordance with these recommendations. Upon successful completion of the test, the configuration of the assembly, as well as the manufacturer's recommendations for the product application procedure, become a part of the listing for the particular design. Compliance with all the manufacturer's instructions for the SFRM application is thus mandated.

Common requirements in the field application procedures stipulated by manufacturers are as follows:

1. Application shall be in accordance with the manufacturer's listing and recommendations.
2. All surfaces receiving spray-applied fire-resistive material (SFRM) shall be thoroughly cleaned of oil, grease, dirt, loose paint, loose mill scale and any other matter that will impair bond.
3. All clips, hangers, supports, or sleeves are to be installed prior to application of SFRM.
4. All ducts, pipes, conduit, etc. shall be installed after the application of SFRM.
5. Generally, SFRM can be applied to galvanized steel or surfaces coated with a pre-qualified primer/paint. If bond

seal is required, or if unclassified paint is used, metal lath may be required to assure proper adhesion to the steel.

Equally important are the inspection procedures that verify the fire protection material actually applied and in-place in a building is as specified in terms of proper chemical composition, density and thickness. Proper inspection also serves to verify adequate cohesion and adhesion. The relevant ASTM standards were given previously in 2.15. These factors are all essential to enabling the successful fire resistive performance of a rated product, member, or assembly consistent with a particular design listing.

### **2.18 It appears that some of the ASTM fire standards are undergoing revision. Are there problems with these standards?**

ASTM standards, like other standards, are revised routinely every few years. Like most codes and standards, revisions and updates are regularly promulgated on a periodic basis to include new technologies, information and methods, as well as new materials. As such, revisions are signs of improvements and advancements, not problems.

### **2.19 How does a fire affect steel connections?**

Large-scale fire tests, such as that in Cardington (Newman et al, 2000), have yielded some data on connection performance, as has anecdotal observations from analytical studies and past fire incidents in steel-framed buildings. Steel connections usually contain more material in the plates, angles, bolts and other connection elements than the members they connect, which is helpful to their fire resistance. Also, and more importantly, member end connections often have less exposure to heat from a fire and a higher capacity for heat dissipation because of their usual proximity to other members along the fire compartment perimeter, allowing the heat of the fire to be shed to adjacent floor bays, beams and columns that may not be simultaneously subjected to fire. Therefore, it has generally been accepted that temperatures are likely to develop faster, and to higher levels, in steel members than in their end connections, except when an interior splice or connection is subject to a fire exposure identical to that of the main member within the fire compartment.

Equally important are the thermal forces in the framing system that can be induced in these connections and members due to compressive restraint or catenary tension during a fire and after, during the cool-down phase. The forces and bending moments in the heated frame may change dramatically during the course of a fire, although the gravity loads remain unchanged. For example, a restrained beam that is heated will initially try to expand, and compressive axial forces (thrust) will be induced from the constraint present in the surrounding structure, acting in combination with the

**Table 2.1 Estimated Weight and Cost of Representative Fire Protection Materials (for a 2-hour fire rated, light steel column) in New Construction**

Product Type	Avg. Density, lbs/ft <sup>3</sup> (kg/m <sup>3</sup> )	Min. Thickness, in. (mm)	Product Weight, lbs/ft <sup>2</sup> (kg/m <sup>2</sup> )	Installed Cost, \$/ft <sup>2</sup> (\$/m <sup>2</sup> )
Heavy inorganic (concrete)	150 (2400)	1.75 (44)	22 (107)	5-12 (54-129)
High-density inorganic SFRM	40-80 (640-1280)	0.6 (15)	2.0-4.0 (10-20)	3-6 (32-64)
Medium-density inorganic SFRM	20-27 (320-430)	1.5-1.8 (38-46)	2.5-4.0 (12-20)	3-6 (32-64)
Very light organic mastic	18-25 (290-400)	0.5 (13)	0.75-1.0 (4-5)	3-25 (32-269)
Low-density inorganic SFRM	11-15 (180-240)	1.5-1.8 (38-46)	1.8-2.3 (9-11)	1-2 (11-21)

applied bending moments and shear forces from the existing loads. As the fire continues and the member properties degrade, the beam could sag and locally deform or buckle, giving rise to catenary action, which impose tensile forces. The connections must be capable of transferring these forces or sustaining the associated deformations. These fire induced forces and deformations are not explicitly considered in conventional structural design (of any material), which considers a beam to be a primary member for bending resistance only. Performance-based design and research may give some opportunities for advancing this knowledge in the future (see 8.1 and 8.2).

Below steel temperatures of approximately 1,100 °F (600 °C), the strength of welds and ASTM A325 and A490 high strength bolts are not affected. However, a comprehensive set of limit states and detailed constitutive properties on the behavior of high-strength steel bolts, welds, miscellaneous connection attachments or reinforcing details are not yet well known throughout the full-range of elevated temperatures. This paucity of data is compounded by the large variety of possible structural connections, of moment resisting (rigid), and simple shear or axial type, and the different available geometrical and connection size configurations for each.

See also Section 2.20.

## 2.20 What are the current fire protection requirements for connections?

It has been recognized that connections need protection at the same level as the adjacent structural member with the highest fire-rating. For example, the following requirements are provided in the IBC:

*Section 713.2.2 Column protection above ceilings.*

*Where columns require a fire-resistance rating, the entire column, including its connections to beams and girders, shall be protected.*

*Section 713.2.4 Attachments to structural members.*

*The edges of lugs, brackets, rivets, and bolt heads attached to structural members shall be permitted to extend to within 1 in. (25 mm) of the surface of the fire protection.*

Likewise, NFPA 5000 requires additional attention to the columns and connections as follows:

*Section 7.2.7.5 In addition to the requirements of 7.2.7.3 and 7.2.7.4, columns shall meet the following requirements:*

- (1) Where columns require a fire resistance rating, the entire column, including its connections to beams or girders, shall be individually protected.*
- (2) Where the column extends through a ceiling, the fire-resistive protection provided for the column shall be continuous from the top of the floor through the ceiling space to the top of the column.*

There are no standard fire resistance tests or associated ratings for structural connections in any material. Nevertheless, the above code provisions in combination with all the other fire resistance and fire safety regulations have historically proven to be adequate. It is also common that connec-

tions receive somewhat more fire protection than the adjacent structural member with the highest fire rating because of the realities of the application methods.

More recent analytical studies indicate that somewhat reduced protection localized over bolt heads does not lead to excessive heating of bolted connections because of the additional mass of steel present there. Therefore, the ECCS (2001) requires that the fire protection cover over a bolt head should be at least 50 percent as thick as the protection on the adjacent steel member.

### **2.21 How do the various steel fire protection products compare on a weight and cost basis?**

Costs are difficult to accurately estimate, primarily because of variations in region, the multitude of requirements for the various building types, and the ever-changing economic conditions of supply and demand. In general, Table 2.1 gives an estimated range of the expected weights and costs benchmarked to the year 2002 for the five classes of fire protection materials that could be used to achieve a 2-hour rating for a light steel column in new construction. The product weight listed is rounded up slightly, conservatively accounting for over-application of the fire protection material on the job site.

Popular use of the lighter and less expensive SFRM for new buildings usually results in an average in-place cost in the US of about \$0.65 to \$0.75 per “board foot”. A “board foot” is 1 in. of protection material thickness over a surface area of 1 square foot (i.e. the quantity of  $\frac{1}{12}$  cubic foot of the in-place protection material). This is different than the installed cost in Table 2.1, which refers to the cost of protection (of required thickness) per square foot of (protected) steel surface area.

Light- and medium-density mineral fiber products typically will have slightly lower cost for application labor than their wet cementitious plaster counterparts. This is due to the on-site efficiencies of the dry ingredient mixing and spraying operation, which includes the ability to achieve the required spray-on thickness in just one application and easy sweeping clean-up of the over-spray.

The retrofit or repair of fire protection materials in an existing building will be substantially more expensive than that for new construction. The actual cost will depend on a number of factors, including the extent of needed material removal and steel surface preparation, in-place physical obstructions, and any health and working constraints for the continuing building occupancies. This type of work is unique to the project at hand, and must be individually estimated.

# Section 3

## U.S. BUILDING CODE CRITERIA AND USE OF PRESCRIPTIVE FIRE RESISTANCE RATINGS

### 3.1 What is the current status of the national model building codes in the US?

There have traditionally been three national model building codes in existence in the US:

- Basic Building Code, published by the Building Officials and Code Administrators International (BOCA)
- Standard Building Code, published by the Southern Building Code Congress International (SBCCI)
- Uniform Building Code (UBC), published by the International Conference of Building Officials (ICBO)

These three national model code organizations successfully unified their respective codes into a single document, titled the *International Building Code (IBC)*, which was first released in 2000 under the auspices of the International Code Council (ICC), in cooperation with the 3 model code organizations themselves. This model building code became known as IBC 2000, and was intended as a singular replacement for each of the prior three separate model codes in all jurisdictions. Independently, the National Fire Protection Association (NFPA) initiated efforts to establish a separate national model building code, titled *NFPA 5000 Building Construction and Safety Code*, which was first released in 2003.

As a practical matter, given the inherent time lags and regular multi-year update intervals in the local building code adoption process, the country currently has a mixture of at least 5 model codes that are in some stage of usage on the local level. While the last editions of the three model codes of ICBO, BOCA, and SBCCI from approximately 1997-2000 and earlier are clearly being phased out, vestiges of these three codes remain.

Nevertheless, the IBC and NFPA 5000 model building codes are the most prominent model codes for present and future design and construction. These two modern codes are generally similar in terms of both structural design and fire resistance requirements for structural steel systems.

As before, local jurisdictions will have a choice of which model code they select to adopt, and with what, if any, particular modifications. Many municipalities, counties, and states historically have produced their own building code for the area, but most of these are based in large part on one of the national model codes, with possible local modifications or additions.

The remainder of this Chapter will address and reference the cited provisions in both the IBC and NFPA 5000 model codes. The reader is strongly encouraged to verify the requirements in the governing local building code, and the referenced national code and standards, for all the pertinent code requirements in a particular jurisdiction.

### 3.2 How do the IBC and NFPA 5000 model building codes differentiate the various forms of construction, their size and occupancies?

One basic classification method that long been used by the building codes is to separate buildings into various occupancy categories and use group sub-categories. The IBC lists 10 occupancy categories, while NFPA 5000 has 11, such as assembly, business, educational, and factory/industrial. These categories are further segmented into use groups that are specifically described. For example, the assembly (A) occupancy in IBC has 5 possible groups: A-1 through A-5.

The types of construction essentially distinguish between the combustibility or noncombustibility nature and the degree of fire resistance of the primary structural framing material. The principal structural elements of the building in Types I and II construction are required to be noncombustible, with some minor exceptions. Steel construction is noncombustible, and is considered as either Type I or II construction. Progressively more combustible (wood or plastic) structural elements are allowed in Types III and IV construction. For Type V, any materials permitted by the code are allowed.

This code system thereby specifies the highest inherent structural fire resistance to Types I and II, and the least to Type V. Accordingly, the more critical building occupancies and uses are prescribed to have the preferred Type I and II construction designations, with accompanying more liberal heights and area limitations. Types III, IV and V are progressively more restrictive in terms of allowable heights and areas. The building size, footprint, and its fire protection are typically determined in conjunction with the occupancy and type of construction allowed by the code.

In many instances, these model building codes allow unprotected steel buildings for the low-rise commercial buildings that are within the given area limits in accordance with Type IIB Construction.

The allowable heights and areas (see Table 503 in the IBC, Table 7.4.1 in NFPA 5000) contain the detailed infor-

mation that delineates the various occupancy groups, heights and area limitations, and types of construction. These allowable heights and areas are the baseline reference, from which further increases are possible when provided with such considerations as sprinklers and frontage separation. For example, for Type IIB Construction (unprotected noncombustible) in IBC, Type II(000) in NFPA 5000, the allowable per floor area can be increased almost four-fold by utilizing these area additions due to frontage distance and sprinklers. For certain occupancies, the maximum area is not limited at all in unprotected noncombustible one- and two-story buildings, where additional frontage distance requirements are satisfied. Note that Types IA and IB in the IBC, as well as Types I(442), I(332) and II(222) in the NFPA 5000, list the greatest allowed heights and areas, which in many cases are unlimited by the code.

Automatic sprinkler systems are required for certain occupancies and heights based on floor area thresholds. With the exception of open-deck parking garages and airport control towers, all occupancies having a floor with 30 or more people at 55 ft above the lowest level of fire department access must be sprinklered.

Another special occupancy of interest is the so-called high-rise building, which is defined by the code as one having an occupied floor more than 75 ft above the lowest level of fire department vehicle access. Automatic sprinklers are required for all high-rise buildings, with just a few exceptions in the IBC and no exceptions in NFPA 5000. Where sprinkler control valves for each floor are present, a reduction of the Type IA Construction to Type IB requirements, and generally from Type IB Construction to Type IIA requirements is permitted in the IBC. Similar reductions are allowed in NFPA 5000 from Type I(442) to Type I(332), from Type I(332) to Type II(222), and for most occupancies, from Type II(222) to Type II(111), if an additional requirement of exits constructed as smoke-proof enclosures is satisfied. These construction Type reductions are important in determining the minimum required fire resistance ratings for the building elements. The justification for these provisions is the well-documented effectiveness of sprinklers in accomplishing the early control and suppression of a fire.

### **3.3 How are the prescriptive fire resistance ratings specified by the code?**

The fire resistance ratings for building elements have historically been defined as a function of the type of construction that is employed. These specific hourly time requirements have been based on engineering judgment, past experience, and approximate correlations of the standard ASTM E119 fire exposure to the expected fire risks of the various identified occupancies. Table 3.1 (Table 601 from the IBC) gives these fire resistance rating require-

ments, which are generally representative of US construction practices over the last several decades. Table 7.2.2 in NFPA 5000 specifies similar information.

Some important observations can be made about Table 3.1:

- Consistent with the general pattern that Type I is the most fire-resistant construction, it has the highest hourly fire-resistance requirements. These required rating times progressively decrease to the right of this Table.
- There are also different categories of structural elements that are referenced: frames, floors, walls, and roofs. The structural frame is defined as all the members that are designed to carry gravity loads, in particular the columns and girders. The frame is not intended to include the roof or floor, since these are considered to be more localized gravity systems and are treated separately in the code. For Type IA Construction, the columns and girders are required to have one hour more of fire resistance than the floor. For Type IB and lower construction, the gravity framing and floors have identical fire resistance requirements.
- Roof construction is typically allowed to have a lower fire resistance than either the frame or floors. One of the footnotes to the IBC Table 601 states that the requirements for framing that supports the roof only may be reduced by 1 hour. Another footnote states that the roof construction itself, except for the industrial and higher hazard occupancies, need not be fire protected when every part of the roof structure is at least 20 ft above the floor immediately below. Similar provisions are specified in NFPA 5000.

In high-rise buildings, special requirements for automatic sprinklers allow the Type IB construction requirements to be used for a Type IA building, and Type IIA requirements for a Type IB building. The practical implication of this for a Type IA building is a 1-hour reduction, from 3 hours to 2 hours, in the minimum fire resistance for the frame girders and columns; for a Type IB building, it is a 1-hour reduction for both the columns and floors, from 2 hours to 1 hour. These allowable fire resistance reductions are significant, and, along with the available Type IIB Construction provisions for zero rating time (unprotected steel) in low-rise buildings, their use can result in meaningful cost savings on a given steel project with equivalent safety.

Table 3.2 is from NFPA 5000 (Table 7.2.2). The Roman numeral provides the relative fire resistance and combustibility of the structural elements. The lower the number the more fire resistive the construction type. The Arabic numbers following each basic type of construction (e.g., Type I, Type II) indicate the fire resistance rating requirements for certain structural elements as follows:

**Table 3.1 Fire Resistance Ratings from the IBC  
(IBC, 2003)**

**TABLE 601  
FIRE-RESISTANCE RATING REQUIREMENTS FOR BUILDING ELEMENTS (hours)**

BUILDING ELEMENT	TYPE I		TYPE II		TYPE III		TYPE IV	TYPE V	
	A	B	A <sup>d</sup>	B	A <sup>d</sup>	B	HT	A <sup>d</sup>	B
Structural frame <sup>a</sup> Including columns, girders, trusses	3 <sup>b</sup>	2 <sup>b</sup>	1	0	1	0	HT	1	0
Bearing walls Exterior <sup>f</sup> Interior	3 3 <sup>b</sup>	2 2 <sup>b</sup>	1 1	0 0	2 1	2 0	2 1/HT	1 1	0 0
Nonbearing walls and partitions Exterior Interior <sup>e</sup>	See Table 602 See Section 602								
Floor construction Including supporting beams and joists	2	2	1	0	1	0	HT	1	0
Roof construction Including supporting beams and joists	1 1/2 <sup>c</sup>	1 <sup>c</sup>	1 <sup>c</sup>	0 <sup>c</sup>	1 <sup>c</sup>	0	HT	1 <sup>c</sup>	0

For SI: 1 foot = 304.8 mm.

- a. The structural frame shall be considered to be the columns and the girders, beams, trusses and spandrels having direct connections to the columns and bracing members designed to carry gravity loads. The members of floor or roof panels which have no connection to the columns shall be considered secondary members and not a part of the structural frame.
- b. Roof supports: Fire-resistance ratings of structural frame and bearing walls are permitted to be reduced by 1 hour where supporting a roof only.
- c.
  1. Except in Factory-Industrial (F-I), Hazardous (H), Mercantile (M) and Moderate-Hazard Storage (S-1) occupancies, fire protection of structural members shall not be required, including protection of roof framing and decking where every part of the roof construction is 20 feet or more above any floor immediately below. Fire-retardant-treated wood members shall be allowed to be used for such unprotected members.
  2. In all occupancies, heavy timber shall be allowed where a 1-hour or less fire-resistance rating is required.
  3. In Type I and Type II construction, fire-retardant-treated wood shall be allowed in buildings not over two stories including girders and trusses as part of the roof construction.
- d. An approved automatic sprinkler system in accordance with Section 903.3.1.1 shall be allowed to be substituted for 1-hour fire-resistance-rated construction, provided such system is not otherwise required by other provisions of the code or used for an allowable area increase in accordance with Section 506.3 or an allowable height increase in accordance with Section 504.2. The 1-hour substitution for the fire resistance of exterior walls shall not be permitted.
- e. For interior nonbearing partitions in Type IV construction, also see Section 602.4.6.
- f. Not less than the fire-resistance rating based on fire separation distance (see Table 602).

- First Arabic Number—Exterior bearing walls.
- Second Arabic Number—Columns, beams, girders, trusses and arches, supporting bearing walls, columns, or loads from more than one floor
- Third Arabic Number—Floor construction

Thus, a required assembly of Type II (222) will have to utilize non-combustible materials (Type II), and will have to be designed with 2 hour fire resistance ratings for all bearing walls, columns, beams and girders. In addition, the required floor separations will have to achieve a two hour rating.

To comply with these required fire resistance times, the codes provide convenient semi-empirical methods, charts, and tables for all the conventional building materials: steel, concrete, masonry, and timber. These prescriptive design aids are primarily based on past fire test data results and its correlations, mainly as derived from the ASTM E119. For

steel construction, the various methods described in Section 5 for determining the fire resistance of beams, columns, floors, and trusses are usually referenced, or directly included in the code. In particular, ASCE/SFPE 29-99, *Standard Calculation Methods for Structural Fire Protection*, offers a concise and authoritative synopsis of the application of fire resistance ratings for the different types of generic structural members and assemblies. The UL Fire Resistance Directory also contains a compilation of fire-rated designs that contain some non-generic proprietary products.

### 3.4 Besides fire resistance, what other fire protection requirements are usually included in the codes?

Fire resistance requirements are intended to provide for life safety by preventing fire spread and delaying the structural degradation of the structure until all the building occupants have had an opportunity to evacuate the premises. However, fire resistance alone does not provide for any specific

**Table 3.2 Fire Resistance Ratings from NFPA 5000**

**Table 7.2.2 Fire Resistance Ratings for Type I through Type V Construction (hr)**

	Type I		Type II			Type III		Type IV	Type V	
	442	332	222	111	000	211	200	2HH	111	000
<b>Exterior Bearing Walls<sup>a</sup></b>										
Supporting more than one floor, columns, or other bearing walls	4	3	2	1	0 <sup>b</sup>	2	2	2	1	0 <sup>b</sup>
Supporting one floor only	4	3	2	1	0 <sup>b</sup>	2	2	2	1	0 <sup>b</sup>
Supporting a roof only	4	3	1	1	0 <sup>b</sup>	2	2	2	1	0 <sup>b</sup>
<b>Interior Bearing Walls</b>										
Supporting more than one floor, columns, or other bearing walls	4	3	2	1	0	1	0	2	1	0
Supporting one floor only	3	2	2	1	0	1	0	1	1	0
Supporting roofs only	3	2	1	1	0	1	0	1	1	0
<b>Columns</b>										
Supporting more than one floor, columns, or other bearing walls	4	3	2	1	0	1	0	H	1	0
Supporting one floor only	3	2	2	1	0	1	0	H	1	0
Supporting roofs only	3	2	1	1	0	1	0	H	1	0
<b>Beams, Girders, Trusses, and Arches</b>										
Supporting more than one floor, columns, or other bearing walls	4	3	2	1	0	1	0	H	1	0
Supporting one floor only	2	2	2	1	0	1	0	H	1	0
Supporting roofs only	2	2	1	1	0	1	0	H	1	0
<b>Floor Construction</b>	2	2	2	1	0	1	0	H	1	0
<b>Roof Construction</b>	2	1½	1	1	0	1	0	H	1	0
<b>Interior Nonbearing Walls</b>	0	0	0	0	0	0	0	0	0	0
<b>Exterior Nonbearing Walls<sup>c</sup></b>	0 <sup>b</sup>	0 <sup>b</sup>	0 <sup>b</sup>	0 <sup>b</sup>	0 <sup>b</sup>	0 <sup>b</sup>	0 <sup>b</sup>	0 <sup>b</sup>	0 <sup>b</sup>	0 <sup>b</sup>

Note: H = heavy timber members (see text for requirements).

<sup>a</sup>See 7.3.2.1.

<sup>b</sup>See Section 7.3.

<sup>c</sup>See 7.2.3.2.13, 7.2.4.2.3, and 7.2.5.6.8.

fire suppression countermeasures or emergency egress, and it contributes only one part to the fire safety, as discussed earlier in Section 1.

Thus, several complementary fire and life safety features are necessary to enable adequate fire response and the safe exiting of the occupants of a building in the event of a fire emergency. These include:

- Compartmentalization, with both horizontal and vertical fire barriers.
- Fire alarm and detection devices.
- Automatic sprinklers.
- Smoke control.
- Egress provisions, including exits, stairs, elevators, and their locations and distances.

The codes control these features in a prescriptive manner based on building occupancy and type of construction. All these are important measures that help to preserve public safety. Some are as critical, or more so, than just the fire resistance rating of the structural framing itself. During the growth and early burning stages of a fire, it is the combustibility of the construction and these supplementary fire protection elements that most greatly influence the level of life safety.

### 3.5 How are the many different architectural, electrical and mechanical features of a building system considered in its fire resistance design?

The architectural, electrical and mechanical systems are often developed as the project proceeds, and many are subject to change until the building is finished. The fire resistance will be affected by associated requirements, such as floor and wall penetrations, ductwork, joints, and room usage and contents. Coordination is therefore required to



ensure that these factors are considered and the building complies with the requirements of the fire and life safety provisions in the code. See also Section 3.6.

It is also possible that the intended function of a building, or at least a part of it, will be different for the final construction than as initially designed for fire protection. As an extreme example, consider a space originally designated for office occupancy changed for use as an emergency control center with backup generators fueled by local diesel tanks. This and even more minor changes of use require review for compliance with the associate fire protection requirements.

### **3.6 What ASTM standards relate to penetrations and joints in building construction for fire safety?**

ASTM E814 (ANSI/UL 1479) *Standard Test Method for Fire Tests of Through-Penetration Firestops* was first published in 1981 to address the fire safety implications of the many architectural, electrical and/or mechanical system openings that commonly become necessary in actual construction through fire barriers (walls and floors) with a required fire resistive rating. The ASTM E814, F rating measures the time during which flame passage through the firestop system is prevented, at which time it must be accompanied by a successful hose stream test. In addition to the F rating criteria, the T rating requires the temperature rise on the unexposed surface of the wall or floor, on the penetrating item, and on the penetration fill material to not exceed 325 °F (181 °C) above ambient. A third criterion, the L rating, determines the amount of air leakage. The IBC Sections 711.3.1.2 and 711.4.1.2 specify the firestopping requirements for through-penetrations in vertical and horizontal assemblies by reference to ASTM E 814, and its F and T ratings, in order to preserve the fire resistance ratings of the associated assemblies.

The means by which fire protection of through-penetrations is accomplished is called fire-stopping, which ASTM E814 defines as “specific construction of the materials that fill the opening around penetrating items such as cables, cable trays, conduits, ducts, pipes, and their means of support through the wall or floor opening to prevent the spread of fire.” Another common term that is used in codes is “fire-blocking”, which is not the same as fire-stopping in penetrations. Rather, fire-blocking means the prevention of free passage of flames to other areas of a building through concealed spaces, such as a suspended ceiling plenum.

In a similar manner and purpose to through-penetrations of fire rated structural systems, ASTM E1966 (ANSI/UL 2079) *Standard for Tests for Fire Resistance of Building Joint Systems* was subsequently first issued in 1994 to address construction joint systems, such as floor-to-floor joints, wall-to-wall joints, floor-to-wall joints, and head-of-wall joints. The important presumption and prerequisite of this test standard is that both of the construction elements

meeting at the joint must be fire rated, and not contain unprotected openings, such as windows.

There is currently serious professional debate and ongoing ASTM committee work to define the appropriate standard fire test and requirements for perimeter joints between a rated floor assembly and a non-rated curtain wall, probably adjacent to window openings. This condition does not match the assembly contemplated in ASTM E1966.

### **3.7 What do the Codes say about “restrained ratings”?**

The IBC, Section 703.2.3 states:

*Fire-resistance-rated assemblies tested under ASTM E119 shall not be considered to be restrained unless evidence satisfactory to the building official is furnished by the registered design professional showing that the construction qualifies for a restrained classification in accordance with ASTM E119. Restrained construction shall be identified on the plans.*

NFPA 5000, Section 1.7.6.3.1.6 states:

*The classification of fire-resistance-rated floor and roof construction shall be identified on the plans as restrained or unrestrained. Only where a registered design professional has furnished documentation satisfactory to the authority having jurisdiction verifying that the construction is restrained as specified in 8.2.1.2 shall the construction be considered restrained.*

These provisions highlight that restrained rating classification should be adequately considered. The background information and references in Section 4 will often serve as suitable documentation to justify a restrained assembly rating for structural steel framing. Note that, for fire resistance times of 1 hour or less, there is no difference between restrained and unrestrained ratings, in accordance with the ASTM E119 definitions.

### **3.8 Are there methods beyond the prescriptive approaches in the building codes that can be used to satisfy code fire safety objectives?**

As with any other alternatives or variances to the building code, such exceptions, special considerations, substitutions, or innovations that are not explicitly covered by the code must be submitted, evaluated, and approved on a case-by-case basis with the building official having jurisdiction. IBC Section 104.11 covers alternative materials, design, and methods of construction and equipment, and provides the means for consideration of suitable alternatives. Likewise, NFPA 5000 Section 1.5 permits equivalent designs to be employed. Usually, appropriate explanations and/or docu-

mentation are submitted to the building official to justify that the proposed alternatives meet or exceed the minimum intent of the code. The use of these provisions is often sought in connection with a performance-based design, wherein more advanced, realistic, and/or project-specific measures are recommended in lieu of the general standard provisions.

### **3.9 What are the typical ways that fire resistance can be evaluated?**

The ways to justify fire resistance, as required by the codes, include:

- Fire resistance listings, such as the UL Fire Resistance Directory.
- Standard fire tests.
- Expert opinion.
- Modeling.
- Performance-based design.

Compliance with the prescriptive code requirements is most often accomplished on projects by a direct use of referenced fire resistance listings, based on past standard fire tests. Such usage of assembly or design listings presupposes that the construction to be used matches that previously tested. If a new assembly or material is employed in construction, a standard fire test can be conducted in order to develop the appropriate fire resistance ratings for this prototype.

Expert opinion and modeling could well be considered to be merely elements of the general performance-based design, as discussed further in Section 8. These approaches all rely on substituting alternative rational solutions to the general standard provisions of the code, all subject to the review and approval of the building code official.

## Section 4

# THE ASTM E119 STANDARD FIRE TEST

### 4.1 What are the test procedures and acceptance criteria specified in ASTM E119?

ASTM E119 is applicable to individual beams, columns, floors, walls, and other building elements of any material. Each test assembly or element is subjected to a standard fire in a furnace compartment of a certain extent and severity, the so-called standard time-temperature exposure curve. The resultant fire-resistance rating is expressed as the number of hours that the assembly or element was able to withstand exposure to the standard fire before a limiting criterion was reached.

One critical test limit is the time when the member or assembly can no longer support the applied load (the maximum design load, unless specified otherwise). Alternative limit point, or the only one if tested without loading, is a limiting temperature of the steel specimen under the standard fire exposure. For floor, wall, and roof construction, an additional ASTM E 119 acceptance criterion exists for the maximum temperature rise on the unexposed surface of the specimen, or ignition of a cotton wool pad. The standard ASTM E 119 test thereby evaluates the relative heat transmission characteristics and structural integrity of specimens under a common, and well-controlled, fire exposure

Table 4.1 summarizes the pertinent temperature end point criteria of in ASTM E119 for the various types of structural members and assemblies. These critical temperatures have been selected as conservative estimates of the maximum allowed reduction in strength of the structural members under elevated temperatures, approximately near the 50 percent level. See Sections 2.4 and 2.5 for further information.

The minimum area exposed to the fire for floor and roof assemblies in the ASTM E119 test must be at least 180 ft<sup>2</sup>, with neither dimension less than 12 ft. The UL furnace for floor and roof testing is approximately 14 ft by 17 ft.

### 4.2 Are structural steel systems restrained or unrestrained? What is the difference between “restrained” and “unrestrained” ratings?

Appendix X3, Table X3.1 of ASTM E119 provides guidance on the classification of beams, floor and roof systems in construction as restrained or unrestrained. As reproduced here in Table 4.2, in most practical cases, structural steel beams and steel framed floor systems within steel framed buildings are classified as restrained. See also Section 4.3 and Gewain and Troup (2001).

The differences in fire protection costs between restrained and unrestrained steel framed floor construction

for required fire resistance ratings of more than 1 hour can be as much as 30 cents per square ft (for low density SFRM protection), with the unrestrained ratings resulting in the more expensive designs. For fire resistance ratings of 1 hour or less, the ASTM E119 definitions do not result in any difference between the restrained and unrestrained ratings.

Many associate the difference between restrained and unrestrained ratings for beams, floors and roofs with the ASTM E 119 test arrangements either allowing for the free thermal expansion and end rotation of the tested specimen (an unrestrained test) or not (a restrained test). However, in most cases the unrestrained ratings are obtained from tests on restrained specimens based on temperature limit criteria. Therefore, in general, unrestrained ratings are not representative of fire resistance, but are rather indicators of the time when steel deck or steel beam temperatures reach the specified level. In contrast, restrained ratings reflect both the fire separating and the loadbearing performance, and therefore, are more representative of fire resistance. The following summarizes how these ASTM E119 ratings are developed.

- Tests on unloaded beams can be performed with restrained or unrestrained beam specimens. However, ASTM E 119 specifically requires that the longitudinal expansion of the applied fire protection material in this test has to be restrained. Such test without applied structural load results in a single unrestrained beam rating based on the period of fire exposure where the average measured temperature at any section of the steel beam remains under 1,000 °F, and the measured temperature at any single location of the steel beam remains under 1,200 °F. While similar type of test is commonly conducted to develop fire ratings for columns, this test is rarely conducted for beams—perhaps only when the laboratory is not equipped with a loading device, or the latter has inadequate capacity to provide the required test load.
- ASTM E119 tests on loaded structural steel and composite steel-and-concrete beams are always restrained and result in two ratings. The first rating is a restrained beam rating based on the period of fire exposure where the beam sustains the applied design load, but not more than twice the corresponding unrestrained beam rating, and provided the latter is one hour or more. The second rating is an unrestrained beam rating based solely on the period of fire exposure where the average measured temperature at any section of the steel beam remains under

**Table 4.1 ASTM E119 Temperature Endpoint Criteria**

<b>Structural Assembly or Member</b>	<b>Temperature Location</b>	<b>Maximum Temperature °F (°C)</b>
Walls and partitions, loaded or not loaded	Average*	250 (139)
	Single point*	325 (181)
Steel columns or beams, not loaded	Steel section average	1,000 (538)
	Steel single point	1,200 (649)
Loaded floor/roof assemblies, the last four criteria also apply in tests on loaded beams	Average*	250 (139)
	Single point*	325 (181)
	Average of steel beams or joints, if spaced at 4 ft or less	1,100 (593)
	Steel deck average	1,100 (593)
	Steel beam section average	1,100 (593)
	Steel beam single point	1,300 (704)
	Tensile pre-stressing steel	800 (427)
	Tensile reinforcing steel.	1,100 (593)

\* Maximum temperature increase on the unexposed surface of the assembly.

1,100 °F, and the measured temperature at any single location of the steel beam remains under 1,300 °F.

- ASTM E119 tests of floor and roof assemblies are always loaded (with maximum design load, unless specified otherwise). The assemblies can be tested in the unrestrained or restrained condition around the floor/roof specimen perimeter. Whenever the tested floor/roof assembly contains a structural steel beam, both restrained and unrestrained assembly tests will result in an unrestrained beam rating (based on the same temperature criteria specified for loaded restrained beam tests) in addition to assembly ratings. For any assembly rating period, the unexposed surface of the tested floor/roof should not develop conditions that will ignite cotton waste, indicate an average temperature rise in excess of 250 °F (139 °C) or exhibit a single point temperature rise in excess of 325 °F (181 °C).
- An unrestrained floor/roof assembly test will result in an unrestrained assembly rating, based on the period of fire exposure where the assembly sustains the applied design load. This test is rarely used for floors/roofs framed with

structural steel because it results in only one assembly rating (in addition to unrestrained beam rating).

- The restrained floor/roof assembly test is the most common test in practice because, in addition to unrestrained beam rating, it results in two assembly ratings: 1) restrained assembly rating based on the period of fire exposure where the assembly sustains the applied design load, but not more than twice the corresponding unrestrained assembly rating, and provided the later is one hour or more, and 2) unrestrained assembly rating based on the same temperature criteria specified for the unrestrained beam rating (additional criteria for unrestrained assembly ratings also apply where the assembly contains steel deck or beams/joists spaced at 4 ft or less).

#### **4.3 What additional information is available to justify the use of restrained fire ratings for steel buildings?**

Gewain and Troup (2001) summarized facts, past research, and historical experience to reinforce the ASTM guidelines, and other assertions, that the restrained rating classification

**Table 4.2 ASTM E119 Guidelines for Restrained and Unrestrained Fire Ratings**

(Reprinted with permission from ASTM.)

**X3. GUIDE FOR DETERMINING CONDITIONS OF RESTRAINT FOR FLOOR AND ROOF ASSEMBLIES AND FOR INDIVIDUAL BEAMS**

X3.1 The revisions adopted in 1970 introduced the concept of fire endurance classifications based on two conditions of support: restrained and unrestrained. As a result, specimens can be fire tested in such a manner as to derive these two classifications.

X3.2 A restrained condition in fire tests, as used in this test method, is one in which expansion at the supports of a load carrying element resulting from the effects of the fire is resisted by forces external to the element. An unrestrained condition is one in which the load carrying element is free to expand and rotate at its supports.

X3.3 This guide is based on knowledge currently available and recommends that all constructions be classified as either restrained or unrestrained. This classification will enable the architect, engineer, or building official to correlate the fire endurance classification, based on conditions of restraint, with the construction type under consideration. While it has been shown that certain conditions of restraint will improve fire endurance, methodologies for establishing the presence of sufficient restraint in actual constructions have not been standardized.

X3.4 For the purpose of this guide, restraint in buildings is defined as follows: "Floor and roof assemblies and individual

beams in buildings shall be considered restrained when the surrounding or supporting structure is capable of resisting substantial thermal expansion throughout the range of anticipated elevated temperatures. Construction not complying with this definition are assumed to be free to rotate and expand and shall therefore be considered as unrestrained."

X3.5 This definition requires the exercise of engineering judgment to determine what constitutes restraint to "substantial thermal expansion." Restraint may be provided by the lateral stiffness of supports for floor and roof assemblies and intermediate beams forming part of the assembly. In order to develop restraint, connections must adequately transfer thermal thrusts to such supports. The rigidity of adjoining panels or structures should be considered in assessing the capability of a structure to resist thermal expansion. Continuity, such as that occurring in beams acting continuously over more than two supports, will induce rotational restraint which will usually add to the fire resistance of structural members.

X3.6 In Table X3.1 only the common types of constructions are listed. Having these examples in mind as well as the philosophy expressed in the preamble, the user should be able to rationalize the less common types of construction.

**TABLE X3.1 Construction Classification, Restrained and Unrestrained**

I. Wall bearing:	
Single span and simply supported end spans of multiple bays: <sup>A</sup>	
(1) Open-web steel joists or steel beams, supporting concrete slab, precast units, or metal decking	unrestrained
(2) Concrete slabs, precast units, or metal decking	unrestrained
Interior spans of multiple bays:	
(1) Open-web steel joists, steel beams or metal decking, supporting continuous concrete slab	restrained
(2) Open-web steel joists or steel beams, supporting precast units or metal decking	unrestrained
(3) Cast-in-place concrete slab systems	restrained
(4) Precast concrete where the potential thermal expansion is resisted by adjacent construction <sup>B</sup>	restrained
II. Steel framing:	
(1) Steel beams welded, riveted, or bolted to the framing members	restrained
(2) All types of cast-in-place floor and roof systems (such as beam-and-slabs, flat slabs, pan joists, and waffle slabs) where the floor or roof system is secured to the framing members	restrained
(3) All types of prefabricated floor or roof systems where the structural members are secured to the framing members and the potential thermal expansion of the floor or roof system is resisted by the framing system or the adjoining floor or roof construction <sup>B</sup>	restrained
III. Concrete framing:	
(1) Beams securely fastened to the framing members	restrained
(2) All types of cast-in-place floor or roof systems (such as beam-and-slabs, flat slabs, pan joists, and waffle slabs) where the floor system is cast with the framing members	restrained
(3) Interior and exterior spans of precast systems with cast-in-place joints resulting in restraint equivalent to that which would exist in condition III (1)	restrained
(4) All types of prefabricated floor or roof systems where the structural members are secured to such systems and the potential thermal expansion of the floor or roof systems is resisted by the framing system or the adjoining floor or roof construction <sup>B</sup>	restrained
IV. Wood construction:	
All types	unrestrained

<sup>A</sup> Floor and roof systems can be considered restrained when they are tied into walls with or without tie beams, the walls being designed and detailed to resist thermal thrust from the floor or roof system.

<sup>B</sup> For example, resistance to potential thermal expansion is considered to be achieved when:

- (1) Continuous structural concrete topping is used,
- (2) The space between the ends of precast units or between the ends of units and the vertical face of supports is filled with concrete or mortar, or
- (3) The space between the ends of precast units and the vertical faces of supports, or between the ends of solid or hollow core slab units does not exceed 0.25 % of the length for normal weight concrete members or 0.1 % of the length for structural lightweight concrete members.

is applicable in steel buildings. The brief, but important, conclusions of this work are as follows:

1. *The unrestrained assembly fire resistance rating for structural steel beam floor and roof systems, based on ASTM E119 temperature criteria only, has no relevance to the behavior of these systems under uncontrolled fires in real buildings.*
2. *The fire endurance of structural steel beam floor and roof construction under uncontrolled fire is enhanced by the interaction of the beams with the other structural elements and constructions that are integral with or surround the exposed assembly.*
3. *All steel beam connections to other structural steel members exhibit both axial and rotational restraint. The least stiff connection typically used for steel framed construction (such as a three-bolt single plate connection) is adequate to develop restrained performance.*
4. *Conclusions drawn from the fire research and computer modeling that have been performed by various agencies, including Underwriters Laboratories, Inc., support the conclusion that a restrained assembly classification and fire protection design is most appropriate for steel beam floor and roof assemblies, and verify the guidance contained in ASTM E119-00, Appendix X3.*
5. *The performance of structural steel beam and concrete floor systems exposed to uncontrolled fires observed during the research and analysis studies conducted during the past 25 years largely explains the excellent performance of these systems during severe fire exposures in unsprinklered, modern high-rise buildings.*

#### **4.4 Where can one find these fire rating classifications of steel, and other, building members and assemblies?**

Fire resistance ratings achieved in accordance with ASTM E119 and other ASTM standards for proprietary products and designs can be found in special directories published by independent fire testing laboratories and other organizations. Many of these listings are now also available online in addition to paper copies. The major sources for such standard fire ratings are:

- *Fire Resistance Directory, Volume I*, Underwriters Laboratories Inc., Northbrook, IL, 2003, updated annually (online directory at [www.ul.com](http://www.ul.com)).

- *Directory of Listed Products*, Intertek Testing Services NA Inc., Cortland, NY, 2003, updated annually (online directory at [www.etlsemko.com](http://www.etlsemko.com)).
- *Directory of Listed Building Products, Materials and Assemblies, Volume II*, Omega Point Laboratories Inc., Elmendorf, TX, 2003, updated annually (online directory at [www.opl.com](http://www.opl.com)).
- *FM (Factory Mutual) Approval Guide*, FM Approvals, Norwood, MA, 2002.
- *Fire Resistance Design Manual*, Gypsum Association, Washington DC, 2000 (available for free download at [www.gypsum.org](http://www.gypsum.org)).

Probably the best known, and most widely used, reference for such in conventional building applications is the UL Fire Resistance Directory. See also Section 5.

#### **4.5 What are the limitations of these fire ratings based on standard tests?**

While the fire ratings based on ASTM E119 and similar standards have long and safely been used in US building design practice, there are implicit limitations and assumptions inherent to these standard test methods that need to be more fully understood. Several of these were discussed at length previously in Sections 1 and 2.

Most of these are generically not unique to fire testing, but apply equally well to other types of physical experiments, including the structural testing that forms the basis of the design requirements for all structures. There are only so many variables, exposure and boundary conditions, number of test samples of appropriate sizes that can be economically and realistically tested for tangible results. These can then serve as validation data for further theoretical and analytical work, or correlation studies that more broadly cover the potential spectrum of application cases. As much as anything, the greatest limitation has been an over-reliance on these prescriptive empirical fire ratings in practice, because they are so relatively easy to use, with the effective exclusion of alternate fire engineering methods that are computationally based.

While ASTM E119 addresses the standard fire testing of individual structural elements and members, none of it has been directly applied to evaluating end connections or interior splices. Thus, in contrast to the extensive ASTM E119 test database on main building members and assemblies, there are relatively few fire test results, and no standardized fire ratings, available for any structural connections. See Sections 2.19 and 2.20.

Again, it should be understood that ASTM E119 is strictly a comparative standardized test of selected structural and product features within a limited furnace space

and one simulated fire exposure. It is not meant to be a direct measure or predictor of actual member, assembly, or building performance in a real fire.

**4.6 Could there be differences in the results of standard fire resistance tests of identical specimens conducted in different laboratories?**

Yes, there could be a substantial difference in the resulting fire resistance ratings for the same type of test specimen. The reason for this is partly due to the natural variation and repeatability of experiments, even when conducted at the same facility for identical specimens. This difference is then further compounded by the standard test variables that may

vary among laboratories, such as furnace size and pressure, instrumentation, method of superimposed loading, and specimen end restraint-support. Finally, even a relatively small difference in fire endurance time, per ASTM E119 criteria, between 2 tests could mean a big change in the final fire resistance rating, if the limiting times are relatively close to the discrete rating period. For example, for a nominal 2-hour ASTM E119 test, a fire endurance time difference of only 5 minutes for the same two specimens, say 118 minutes for one specimen and 123 minutes for the other, would result in a substantial 30-minute differential in their fire resistance ratings, given that these two specimens would then qualify for 1½- and 2-hour ratings, respectively.

## Section 5

# APPLICATION OF ASTM E119 RATINGS

### 5.1 Most of the rated fire designs list specific, and unusually small, steel members. How does one apply these ratings to the many other larger and heavier rolled steel shapes that are available for design?

Fire-rated designs usually show small shapes, like a W10×49 column or a W8×28 beams, because of the size and facility limitations of the fire testing laboratories, cost and ability to compare fire performance with other products. These are given as *minimum sizes*, for which the ratings can be adapted to larger and heavier steel shapes within the other fire design criteria given in the listing, including the steel protection type and thickness tested and specified. This type of simple substitution is easy and conservative, but can be quite punitive in terms of costs, because larger and heavier steel members will be inherently more fire-resistant than smaller and lighter ones, and rationally require less fire protection for a given rating.

This dilemma to improve the efficiency of using experimentally determined fire ratings for discrete assemblies was resolved in the 1970s and 1980s by the American Iron and Steel Institute (AISI), which made empirical correlation studies for all the available steel beam and column fire ratings. Best-fit regression equations were developed to effectively interpolate the required protection thickness requirements for a range of possible steel sections. These equations have enabled much more efficient substitutions of steel members for the minimum size given in the rated design, with appropriate adjustments to the fire protection thickness. Because these correlation equations are based on ASTM E119 test data, all of their derived ratings and calculations have that same genesis, including all the previously stated limitations of the ASTM E119 standard and test ranges. Within certain limits, these equations can also be used to substitute steel shapes that are smaller and lighter than the minimum size specified in the fire-rated design, with an appropriate increase in the thickness of fire protection.

The key parameter in these member substitution equations is the steel shape's  $W/D$  ratio, where  $W$  is the weight of the steel shape in lbs/ft and  $D$  is the heated perimeter of the inside surface of the insulation in inches.

### 5.2 What is the significance of the $W/D$ ratio and how is it calculated?

The  $W/D$  ratio characterizes the thermal mass resistance of the member under fire, with high ratios indicating better fire

resistance capability. This means that members with larger  $W/D$  values will experience a slower temperature rise under equivalent heat exposures than those with a lower  $W/D$  ratio. The explanation for this well-known and verified trend is that a heavier shape will provide a greater heat sink than a lighter member. Also, a smaller value of its heated perimeter means that there is less surface area available for heat transfer, which is again a more favorable situation to limit temperature rise in the steel.

The heated perimeter will depend on the geometry of the steel shape, the fire exposure (whether the flames heat all surfaces or one or more sides is not heated), and the protection profile used (following the contour of the shape or boxed). An interior column may have fire exposure along its entire perimeter, while typically a beam supporting a floor will have the top surface of its top flange shielded from the fire, hence having one less exposed surface.

Another similar variable representing the member weight and fire exposure dimensions, that is commonly used for steel hollow structural sections (HSS) and steel pipe products is the  $A/P$  ratio, where  $A$  is the cross-section area of the shape in in.<sup>2</sup> and  $P$  is the heated perimeter in inches.

Internationally,  $H_p$  is used as the variable for the heated perimeter and this ratio is often expressed for all steel shapes in terms of the reciprocal  $P/A$  value, or “section factor =  $F/V = H_p/A$ ,” with dimensions of 1/m. The  $W/D$  and  $A/P$  ratios (or the reciprocal  $P/A$ ,  $F/V$ , or  $H_p/A$ ) are all mathematically equivalent, with the inclusion of the steel density constant and conversions of the appropriate units. However, because  $W/D$  and  $F/V = H_p/A$  are essentially reciprocals, the higher and better  $W/D$  ratios for member fire resistance translate into lower  $F/V$  or  $H_p/A$  values.

The derived  $W/D$  and/or  $A/P$  ratios have been compiled for many of the standard steel shapes, and are widely used in evaluating both column and beam substitutions for fire ratings. Figure 5.1 shows the heated perimeter determination for steel columns, while Figure 5.2 shows this for steel wide flange beams and girders, for both box and contour protection. Contour protection follows the full perimeter of the steel shape, while box protection encloses any steel shape within a rectangular or square profile that has the overall height-depth and width of the steel member. The difference between the beam and column  $D$  is whether the entire outside perimeter is used, as the worst case for interior columns, or the 3-sided, fire-exposed perimeter for beams.

The  $W/D$  or  $A/P$  values are available for all the common steel shapes, including wide flange beams and columns, tee



sections, channels, angles, hollow structural sections (tubing), and pipes (AISC, 2001). The US customary dimensional units for  $W/D$  are lbs/(in.-ft), and in. for  $A/P$ . For nonstandard, built-up or new shapes, the straightforward weight and dimensional calculations, as shown in Figures 5.1 and 5.2, can be independently made to determine the appropriate member  $W/D$  or  $A/P$  ratio.

**5.3 Given the member’s  $W/D$  or  $A/P$  ratio, how are efficient steel beam substitutions accomplished?**

A heavier beam, or one with a greater  $W/D$  ratio, may be conservatively substituted for the lighter members shown in fire-rated designs with the given protection thickness. However, doing so without compensating for the more favorable thermal resistance characteristics of the beam with the higher  $W/D$  ratio is inefficient. Thus, an empirical relationship developed from fire test results should be used to determine the appropriate reduction in spray-applied material requirements for beams as a function of their  $W/D$  ratios.

A simple linear equation relates the steel beam and SFRM thickness of the particular fire rated design with the intended substitute beam to determine a required protection thickness. In order to realize cost savings, this equation may be used to determine the permissible reduction in beam spray-on thickness for a beam with a larger  $W/D$  ratio relative to the shape listed in a given UL design without any limitation on the maximum value for  $W/D$  ratio. This steel beam substitution equation is widely referenced and accepted by US codes and standards.

UL also offers two other guidelines on beam substitutions. Substitution of noncomposite beams is allowed unequivocally for a listed composite beam. However, composite beams may only be substituted into rated designs for

other composite beams. The justification for this limitation is that the fire exposure places more severe demands on a fully loaded composite beam than its noncomposite counterpart.

Substitution of beam-only designs into floor or roof assembly designs is permitted only for assemblies that have an equivalent, or greater, heat dissipation capacity of the floor or roof construction specified compared to the heat dissipation of the floor or roof assembly in the referenced beam-only design.

**5.4 Where can fire rating requirements and these steel member substitution criteria be found?**

Specifications and methods to determine fire resistance ratings for listed designs of floors, roofs, beams, and columns, with substitution provisions, can be found in most building codes and in some standards, most notably:

- Chapter 8, “Fire Resistive Materials and Construction”, NFPA 5000, *Building Construction and Safety Code*, NFPA, Quincy, MA (2002).
- Chapter 7, “Fire-Resistance-Rated Construction”, *International Building Code*, International Code Council, Falls Church, VA, (2003).
- ASCE/SFPE 29-99, *Standard Calculation Methods for Structural Fire Protection*, Structural Engineering Institute of the American Society of Civil Engineers, Reston, VA, (1999).

While the following are not standards per se, they also contain additional helpful information for these purposes:

- AISC *Manual of Steel Construction, Load and Resistance Factor Design*, 3rd Edition, 2001, AISC, Chicago, IL.

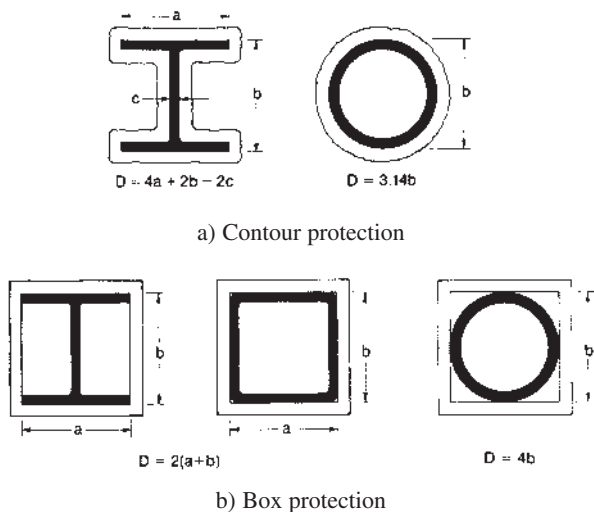

Fig. 5.1.  $W/D$  Ratios for Steel Columns

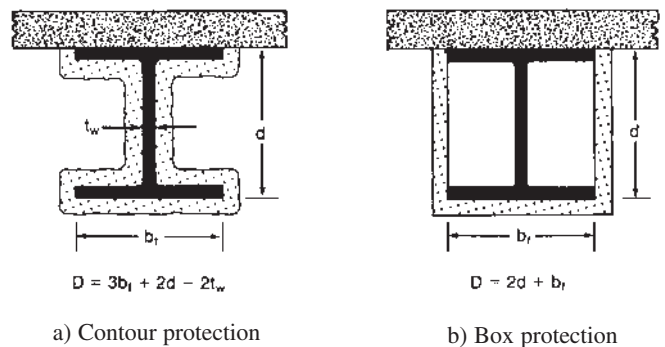

Fig. 5.2.  $W/D$  Ratios for Wide-Flange Steel Beams

- *Fire Resistance Directory, Volume I*, 2002, Underwriters Laboratories Inc., Northbrook, IL.
- *SFPE Handbook of Fire Protection Engineering*, by the Society of Fire Protection Engineers (SFPE), 3rd Edition (2002), Bethesda, MD.

Most suppliers of the various fire protection products also have their own product catalogues and web site directories that highlight their fire rating design listings and related product information.

### 5.5 What are some of the more popular fire rated designs for steel floor systems?

There are literally hundreds of floor assembly designs contained in the UL Fire Resistance Directory, and this number keeps increasing as new design listings are added every year. Usually, the listed design will explicitly specify the minimum size(s) of the steel beam or joist, the floor deck, concrete type and thickness, fire protection material product and thickness, and various other assembly details that were tested, and are required for the assembly to comply with the given fire resistance rating.

Based on past experience, the most commonly cited UL fire rated designs for steel beam and floor deck systems are the following:

- For unprotected deck: D 902 and D 925
- For protected deck with cementitious SFRM: D 759 and D 779
- For protected deck with mineral fiber SFRM: D 832, D 858, and D 871

The primary reason for the popularity of these selected designs is their relative economies. Usually, to qualify for a 2-hour restrained assembly rating with unprotected floor deck, 3/4 in. of lightweight concrete topping over a minimum 2-in.-deep deck will be required. For the steel decks protected with SFRM, 2 1/2 in. of normal weight concrete topping over a minimum 1 1/2-in.-deep deck will be adequate. These possible differences in individual floor slab thickness (minimum total of 5 1/4 in. for unprotected deck or 4 in. for protected deck), type of floor deck, and other slab characteristics are important to take into account early in the architectural floor and elevation layouts, and in the structural designs.

Membrane ceiling protection can also be used for various fire resistance ratings in lieu of SFRM, as given in UL Design D200 and 500 and G 200 and 500 series.

### 5.6 Are there similar member substitution provisions for fire rated designs of steel columns?

Yes, the fire resistance listings give the minimum steel column size necessary for the applicable fire rating—the mem-

ber that was tested—comparable to what was done for steel beams. Again, larger members than the minimum steel size may be conservatively used with the fire protection requirements in a given design. However, if a lighter steel section is to be used for the column, more fire protection will be required. The reason for this adjustment, as in beams, is the increased heat sink capabilities of heavier members with larger *W/D* ratios, which require less insulation than lighter members for the same fire exposure conditions.

This adjustment of fire protection thickness is mandatory only when the fire rated column design is to be extrapolated to a column size that is smaller than minimum size tested, which requires an increased thickness. Otherwise, simplified column protection thickness formulas given in the codes, UL Fire Resistance Directory, or in ASCE/SFPE 29-99 permit calculated interpolation of insulation thickness for both gypsum wallboard and SFRM protection, provided that the steel column shape of interest is within the *W/D* ratio, insulation product and thickness, and fire rating period of columns that have been fire tested. The column substitution equation with SFRM will involve use of SFRM-specific thermal constants. Similar to the methodology for beam substitutions, the column fire endurance equations were derived from, and assume, ASTM E119 test conditions, and thus, they have the same limitations as the ASTM E119 fire resistance ratings.

Column fire ratings are used not only for actual building columns, but also are applied to other members that are principally designed for axial loads, such as truss members and bracing.

### 5.7 How is the fire resistance and protection of fabricated structural steel trusses determined?

Due to the aforementioned size constraints in fire test laboratories, there is very limited direct fire test data on full-scale truss assemblies. UL does not have any published fire ratings specifically for large fabricated steel trusses. Nevertheless, in order to enable a rational fire resistance assessment of these trusses, acceptable methods have been developed to overcome this limitation by applying other existing information from past ASTM E119 tests.

There are three fundamental approaches to the fire protection of a steel truss:

- Membrane fire-resistant ceiling system.
- Individual protection for each truss element, usually with spray-on material, considering each as a column member.
- Enclosing the entire truss assembly for its entire depth and span with fire-resistant materials (enclosure or envelope protection).

Membrane protection is accomplished by specifying a fire-rated ceiling assembly contained in published listings. The individual truss element protection is a conservative approach that treats each member as a column, using the published column listings, as well as the empirical equations discussed in Section 5.6. In the envelope protection approach, layers of rated gypsum wallboard fully enclose the truss, with the board thickness determined by the required fire rating. The required Type X gypsum wallboard thickness will vary from  $\frac{5}{8}$  in. for a 1-hour fire resistance rating, to  $1\frac{1}{2}$  in. for 3 hours.

The nature of the truss fire protection to be used will be influenced, or code mandated, by the truss type and its structural function. Some trusses are simply long-span members. Others types are transfer trusses, staggered trusses, and interstitial trusses. A transfer truss is a critical structural member that carries loads from multiple floor levels above and/or below the truss. A staggered truss system is primarily used in residential occupancy buildings to provide column-free interior spaces. These are story-high trusses that span the full building width at alternating column lines on each floor, supporting loads from two floors at both its top and bottom chords. Interstitial trusses are used to create deep floor/ceiling concealed spaces, often for placement of mechanical or electrical equipment in health-care facilities. The interstitial trusses support the floor above and the loads from the equipment in the concealed space, and may be considered as being analogous to deep open-web joist floor systems for application of membrane protection.

Once the structural function of the fabricated truss is established, the fire protection system can be appropriately selected. Ceiling membrane protection is really only applicable to interstitial trusses, while the envelope and individual member protection methods can be typically used for any steel truss in a building.

### **5.8 Where can one find the fire resistance ratings for composite steel-concrete columns?**

Concrete-filled steel hollow structural sections (HSS), both of circular and square or rectangular cross section, are the only types of composite columns that currently have broadly recognized fire resistance ratings, which can often exceed 2 hours. The supporting research work was primarily performed in Canada at the National Fire Laboratory, in partnership with the Canadian Steel Construction Council and AISI (Kodur and MacKinnon, 2000).

Depending on the size of the steel section, strength of the concrete, and presence of reinforcement, the steel core of the composite column contributes up to 50 percent of the total column capacity at room temperature. After the steel temperature increases due to heating, the steel section gradually loses both its strength and column load-carrying percentage, which causes the concrete to support an increasing

portion of the applied load. Failure occurs when the concrete also can no longer maintain the load. Simple equations were developed both from experimental and analytical data for the fire endurance times of steel HSS columns that are filled with three types of concrete: plain concrete, bar-reinforced concrete, and steel-fiber reinforced concrete. Some of these criteria are covered in Section 5.2.3 of ASCE/SFPE 29-99, but the UL Fire Resistance Directory has no listings for these generic (non-proprietary) designs.

Another important conclusion from this research is the accompanying requirement for small vent holes in the walls of the steel HSS. During a fire, these holes are intended to allow for the escape of water vapor, which prevents bursting of the steel section under the steam pressure generated by the heating of entrapped water in the enclosed concrete of the column. The recommendation calls for four  $\frac{1}{2}$ -in.-diameter vent holes, one on each side of the HSS at each floor level of the building.

Fire-rating equations exist for noncomposite structural steel columns that are encased in concrete for fire protection only. In these cases, the concrete is not intended to be load bearing, but only to provide an insulating cover and heat sink to the interior steel section. ASCE/SFPE 29-99, and other references (SFPE, 2002) have published these fire resistance formulas, limits of applicability, and special requirements needed for use that are based on past regression correlations with fire test results.

### **5.9 Is there information available on the fire endurance of older steel, and other, construction and materials?**

In 1980, the National Institute of Building Sciences (NIBS) produced the first edition of the *Guideline on Fire Ratings of Archaic Materials and Assemblies*. This document listed thousands of design combinations that provided some level of fire resistance for structural assemblies that have been historically used. This Guideline was more recently updated and published in 2000 with the same title for the U.S. Department of Housing and Urban Development (HUD) by NIBS. It includes coverage of:

- Masonry, metal frame, and wood walls.
- Reinforced concrete, cast iron and steel columns with encasements.
- Concrete, steel, wood joist, and hollow clay tile floor systems.
- Reinforced concrete and concrete-encased steel beams.
- Doors.

NIBS/HUD (2000) is available for free download at [www.hud.gov](http://www.hud.gov), and it is useful in reassessing the fire safety of older existing buildings that may be undergoing renovations, repairs, and/or expansions.

# Section 6

## STRENGTH AND REPARABILITY OF STEEL AFTER A FIRE

### 6.1 What happens to structural steel during a fire?

Under fire conditions, the temperatures in the steel will increase, resulting in both thermal expansion of the member and transient deterioration of its mechanical properties. The magnitude of these effects depends upon several factors, including the type of steel and whether it was protected or not. The duration and nature of the fire exposure will affect the temperature distribution in the steel.

Typical curves of the basic material properties at elevated temperatures are given in Section 2. The following discussion covers the common structural steel grades used in building construction, as listed in the AISC Specification, which are essentially of the lower carbon and alloying composition. Heat-treated and high strength alloy steels with yield strengths greater than 70 ksi should be independently evaluated after exposure to the high temperatures of a fire.

There are two basic fire exposures that may occur as a result of a building fire: within the fire compartment itself, and exterior to it on the adjacent outside curtain wall. The latter occurs from flame extensions through broken windows or other openings in the fire room, and due to the subsequent added ventilation together with any through drafts. The effects of this external flaming must be considered when unprotected structural members are present on the building exterior.

The temperature increase in the steel member is governed by the principles of heat transfer. Consequently, it must be recognized that the temperature of the steel member(s) will not usually be the same as the fire temperature in a compartment or in the exterior flame plume. Protected steel will experience a much slower temperature rise during a fire exposure than unprotected steel. Also, fire effects on the steel will be less the greater its distance from the center of the fire, and if more ventilation occurs near the steel in a fuel-controlled condition, wherein the ventilation helps to cool the steel by dissipating heat to the surrounding environment.

For an interior exposure, the upper concrete floor slab, and adjacent unexposed elements (walls and floors) of the building, will all provide additional heat sinks to the fire and steel that may limit the steel's temperature increase relative to what it may have been if the member was in the middle of the fire as an isolated element, or assembly. Also, the time of heating exposure is important, since shorter intervals of high temperatures will be less damaging than

longer ones at the same temperatures. These are all the heat transfer parts of the fire problem that depend on the nature, intensity, and duration of the actual fire in the compartment, and on the distance of the flame to the steel member, the steel shape section properties, type of fire protection or flame shielding, and the surrounding thermal and structural environment.

In general, the fire effects on the metallurgy and properties of structural steel are predominantly temporary while the material is hot. Because the common steels have relatively low carbon and alloying composition, structural steels will usually regain their pre-fire properties upon cooling, provided that the steel temperatures did not exceed about 1,300 °F (700 °C) for more than about 20 minutes. Above these limits, see Section 6.5.

### 6.2 What other physical phenomena occur to steel at high temperatures?

Due to the thermal elongations coupled with reductions in steel strength and stiffness that occur at elevated temperatures, even minor member end restraint, imperfections, crookedness, or force eccentricity can initiate visible local flange and/or web buckling, or overall member buckling, above about 600 °F (315 °C). With complete restraint from thermal expansion, these may occur at temperatures as low as 250 °F (120 °C). Buckling is very likely to occur at temperatures in the 1,200 to 1,400 °F (650 to 760 °C) range, when the strength and stiffness are less than 50 percent of their nominal ambient values. Past experience from flame curving and straightening indicates that local buckling often can occur quite suddenly at, and above, this temperature range.

In addition to these buckling distortions of the member, the steel will experience increasing end rotation and vertical deflections during the fire from the existing dead and live loads. Under fire conditions, both for uncontrolled natural exposures and in standard tests, the temperature-induced deflections of fire-resistive steel beam/concrete floor systems can be large. Actual fires have produced deflections ranging from several inches up to, in extreme cases, 3 to 4 ft, which are an order of magnitude greater than the normal serviceability limits that are anticipated for buildings. In this sense, it must be remembered that the intended structural outcome of fire safety design is to maintain building integrity and prevent (or delay) catastrophic collapse,

despite suffering potentially extensive structural and non-structural damage. Thus, even rated fire-resistive construction will often experience major structural and nonstructural damage during a severe fire.

Figure 6.1 shows a UL test of a roof assembly in the furnace after a successful fire test. Steel deck sag and beam buckling are visible. The effects of actual major fires in two prominent unsprinklered high-rise steel buildings, One Meridian Plaza in Philadelphia and First Interstate Bank in Los Angeles, along with the Cardington test frame in the U.K. (Bailey, 2001 and Newman, 2000) are shown in Figures 6.2 through 6.4, respectively. In the One Meridian Plaza and First Interstate Bank incidents, and other cases that will be further summarized in Section 7, no structural collapses were experienced during these long uncontrolled fires, even though the fire damage was extensive.

It should be noted again that visible deformations are not by themselves indicators that the steel had been heated to temperatures beyond 1,300 °F (700 °C), given the possibility of steel buckling even at lower temperatures, depending on the magnitudes of the actual applied loads. However, and very importantly, the converse is also true - steel that is not grossly deformed and is deemed to be repairable probably did not experience temperatures beyond 1,300 °F (700 °C).

When heated to high levels, steel is also likely to change its external appearance and color. If the steel temperatures have not exceeded about 1,300 °F (700 °C), tightly adherent mill scale will remain, and the color will look normal. At steel temperatures hotter than 1,300 °F (700 °C) for more than about 20 minutes, the steel surface will become

noticeably oxidized and possibly pitted, with some accompanying erosion and loss of cross-sectional thickness. The appearance of significantly “burned” steel is ordinarily light gray or white, but it also could assume the color of the fuel contents in the room, such as black from the combustible residues.

### 6.3 What happens to steel subjected to a fire after the fire becomes extinguished and the steel is allowed to cool?

Steel contracts as it cools. When inelastic deformations occur during a significant fire due to applied service loads and existing thermal restraint, the steel will experience permanent set and will not return to its original shape upon cooling. These geometric changes from fire and subsequent cooling have caused several instances of steel beam connections that were reported to have failed in tension. The residual metallurgical and mechanical properties of the steel after a fire are discussed in the following Sections 6.4 and 6.5.

### 6.4 What evidence exists to support a 1,300 °F (700 °C) steel temperature threshold below which no adverse property changes will occur after cooling?

For most hot rolled shape production, final rolling occurs when the steel is at about 1,600 °F (870 °C) or higher, depending on the mill procedures. Intentionally reheating steel to higher temperatures is also well known for special material treatments, with stress relieving done at temperature range of 1,100 °F to 1,200 °F (590 °C to 650 °C), and annealing and normalizing temperatures reaching 1,500 °F to 1,600 °F (820 °C to 870 °C). Likewise, the traditional and successful heat straightening and curving practices for fabrication of steel members are done at temperatures up to



Fig. 6.1. UL Steel Roof Assembly After Successful ASTM E119 Fire Test (Courtesy of Underwriters Laboratories, Inc.)



Fig. 6.2. One Meridian Plaza in Philadelphia After Feb. 23-24, 1991 Fire (www.sgh.com)

1,200 °F (650 °C). Finally, the ASTM E119 fire test standard specifies a limiting average temperature of 1,100 °F (593 °C) and a limiting maximum temperature of 1,300 °F (704 °C) for unrestrained ratings for steel beams and steel framed floors.

Therefore, if the temperatures in the steel did not exceed the transformation temperature of 1,300 °F (700 °C) for a measurable amount of time, the steel can be expected to have acceptable metallurgical properties upon cooling back to ambient conditions. Its residual properties will be the same, or perhaps better, than in the original pre-fire condition. Smith et al (1981) provides further confirmation data on steel properties after heating and cooling.

### 6.5 What happens when temperatures in the steel reach beyond 1,300 °F (700 °C)? What concerns about metallurgical or residual stress effects have to be considered?

The mechanical properties of the steel continue to degrade with increasing temperatures, as shown in Section 2, until near total strength and stiffness depletion occurs around 2,000 °F (1,100 °C). The actual melting point of steel is in the range of 2,500 °F to 2,700 °F (1,370 °C to 1,480 °C), which can vary with the particular chemistry and accompa-



Fig. 6.3. First Interstate Bank in Los Angeles During May 4, 1988 Fire ([www.lafire.com](http://www.lafire.com))

nying phase changes. However, for practical purposes, relatively little strength and stiffness of steel are retained beyond about 1,300 °F (700 °C), less than 20 percent of the ambient values.

Beyond 1,600 °F (870 °C), steel's metallurgical microstructure undergoes a permanent transformation relative to its original chemical composition that will result in grain coarsening and hardening, which, with the subsequent cooling, will adversely affect its residual mechanical properties. For example, this high level of heating for about 30 minutes or more and cooling will result in a reduced ductility and fracture toughness, as well as higher hardness and elevated yield and tensile strengths.

### 6.6 Can steel continue to be used in a building after it has been in a fire? How can you assess the capacity of steel that has been exposed to fire, and can it be repaired?

A recent and more detailed discussion of these issues is provided by Tide (1998). This paper recommends that a fire-damaged structure be assessed in one of three categories:

- Category 1: Straight members that appear to be unaffected by the fire, including those that have slight distortions that are not easily visually observable.
- Category 2: Members that are noticeably deformed but that could be heat straightened, if economically justified.
- Category 3: Members that are so severely deformed that repair would be economically unfeasible when compared to the cost of replacement.

Category 1 and 2 members are unlikely to have exceeded 1,300 °F (700 °C) for any appreciable length of time during



Fig. 6.4. Unprotected Steel Floor System After 1996 Cardington, U.K. Fire Test (Newman et al, 2000) (Photo courtesy of Corus Research Development & Technology)

the fire. Hence, it can be reasoned that they did not suffer any permanent changes in their properties after cooling back to ambient temperatures. Smith et al (1981) gives further information on steel properties after heating and cooling. The relative economies of straightening versus replacement are particularly relevant for Category 2 since, from a structural performance perspective, these members can be repaired by straightening and remain in service.

The severe fire damage representative of the Category 3 designation usually favors replacement of the member, both due to the higher repair cost and possible adverse residual properties. Such members have probably experienced temperatures in excess of 1,300 °F (700 °C) for a prolonged time, and consequently, may have suffered noticeable, adverse, and permanent external and internal changes during the fire.

Several authors recommend rules of thumb for assessment of steel that may be of use to the reader.

- Tide (1998) recommends: “If it is still straight after exposure to fire—the steel is OK.”
- Dill (1960) provided a similar recommendation: “Steel which has been through a fire but which can be made dimensionally re-usable by straightening with the methods that are available may be continued in use with full expectance of performance in accordance with its specified mechanical properties.” Dill also makes the excellent point that the heat straightening operation of the damaged steel will serve by itself as a further physical test of the strength and ductility of the in-situ steel.
- Wildt (1980) recommends: “In conclusion, structural repair after a major fire in a steel framed building is to be expected. The standard fire tests, by which the assemblies are rated, do not preclude the possibility of damage

short of structural collapse and other limiting end point criteria. But fortunately, in steel construction, the evaluation of damage is relatively straight forward and, for the most part, can be done by visual inspection ... Furthermore, because a structural steel frame is essentially an interconnected construction made up of individual, relatively small pieces, the removal and replacement of members can be undertaken expeditiously, relatively economically and with a minimum of disruption to the remainder of the structure.”

## **6.7 What is the condition of the steel fire protection material after a fire?**

This depends on the nature and duration of the fire exposures, and the amount of visible damage to the material. If it is known that the fire was relatively short and not too hot, the condition of the protection material may be adequate for continued use without any repair or replacement, similar to the underlying base metal. However, if the fire was long and hot, and both the structure and its protection experienced large distortions and damage, then full replacement is necessary. If structural repairs and/or straightening are pursued, its original fire protection will usually also have to be removed and replaced, at least in the areas near the repairs.

Many fire protection materials, such as gypsum board and concrete, will suffer dehydration, cracking and other chemical changes during the course of a longer fire exposure, which will reduce their insulation properties for any subsequent exposures. For these reasons, it may be prudent to simply replace the fire protection material for future use.

Section 2.13 covers effects of damaged fire protection.

# Section 7

## PAST BUILDING FIRE INCIDENTS AND CASUALTIES

### 7.1 How does one reconcile the enormous tragedy of the September 11, 2001 disasters with the excellent previous history of fire safety in U.S. cities and in its tall buildings? What is being done to address these concerns?

On September 11, 2001, terrorists enacted an unprecedented and dreadful attack, which caused structural damage, fire and collapse both in New York City and in Washington, DC. First and foremost, it should be emphasized that this destruction and loss of thousands of lives was principally caused by planned terrorist attacks on densely populated civilian targets in major urban areas, using hijacked commercial aircraft as missiles.

At the time of their design and construction, the World Trade Center (WTC) towers and Pentagon were state-of-the-art buildings. Structural systems are quite often inherently redundant and robust, with members and connections that can provide alternate load paths should a limited number of elements be compromised. However, the extreme building exposures and combinations of events went far beyond normal design criteria.

The catastrophic sequence consisted of extensive impact damage to both the structural framing and the fire protection and life safety systems, followed by immense and extensive steady-state fires. At the present time, no civilian building or system is designed to withstand such an extreme combination of events, nor even the full consequences of any one effect that occurred in New York City on September 11, 2001. It was concluded by the authors of FEMA 403 (FEMA, 2002) that rational risk-benefit evaluation does not support immediate imposition of any design provisions for such extreme loadings and combinations of extreme events.

FEMA 403 (FEMA, 2002) contains a wealth of information on the original structural, architectural, mechanical, fire protection, and other characteristics of the WTC complex, and surrounding tall buildings, the precise chronology and description of the attacks, collapses, and damage, and most importantly, several important observations and conclusions from the Building Performance Study (BPS) Team. ASCE-SEI (2003) provides a parallel reconnaissance report on the Pentagon disaster. These documents serve as the basis for further technical studies on these disasters, which are being conducted by the National Institute for Standards and Technology (NIST).

### 7.2 What are the implications of the World Trade Center and Pentagon experiences?

The authors of FEMA 403 (FEMA, 2002) and the Pentagon report (ASCE-SEI, 2003) concluded that no changes were immediately warranted in building codes and design practice, but provided helpful observations that could lead to improvements in design requirements. Some of the information in these parallel reports prepared by separate groups are consistent:

- Spray-applied fire protection materials in the WTC towers and the fire-protective concrete cover in the Pentagon were destroyed by the impact of the planes and debris wave that ensued. Further studies of the long-term durability and robustness of these fire protection materials under such conditions has been recommended.
- The WTC towers, the surrounding buildings, and the Pentagon demonstrated significant resistance to progressive collapse. Further studies on the mitigation of progressive collapse mechanisms is recommended.
- Fire and smoke alarms, sprinklers, occupant egress through exits and evacuation protocols, widths and locations of stairways, and/or elevators are all topics that are being reconsidered for their life safety effectiveness and redundancies in cases of severe emergencies. Some cost-effective changes in this regard appear feasible in the short-term, at least for the few special landmark buildings.
- These disasters demonstrate the possible outcomes from a combination of extreme events, in which both significant structural and fire protection system damage are present when a fire starts. In these cases, not only were the building structures weakened, their fire control, suppression, and protection measures and egress routes were also destroyed.

### 7.3 What is the historical performance record in fire safety for high-rise buildings, particularly those of steel?

The annual fire occurrences in the U.S., according to Hall (2001), exceed 10,000 in buildings that are 7 stories or



**Table 7.1 High Rise Fire Statistics (Hall, 2001)**

**Table 1. High-Rise Building Fire Experience  
Selected Property Classes, by Year  
1985-98 Structure Fires (Continued)**

**E. Four Property Classes Combined**

Year	Fires	Civilian Deaths*	Civilian Injuries	Direct Property Damage (in Millions)
1985	17,200	66*	665	\$24.9
1986	15,000	37*	554	\$41.5
1987	13,000	55	635	\$36.2
1988	14,600	93	778	\$102.3*
1989	14,800	110	798	\$58.1*
1990	13,300	83	625	\$48.3
1991	13,100	23	747	\$150.1*
1992	13,600	34*	827	\$75.4
1993	12,400	43	701*	\$60.8*
1994	11,300	51	950	\$56.9
1995	10,000	55*	688	\$44.5
1996	12,100	64*	790	\$69.1
1997	11,400	33	560	\$43.4
1998	10,000	37	680	\$41.1

\* In 1985, 1986, 1989, 1991, and 1992, there were 24 total office building fire deaths, all in buildings with unreported height. Since high-rise buildings account for about one-eighth of all office fires, it was estimated that high-rise office buildings had three deaths, allocated as one of the eight 1985 deaths; one of the eight 1986 deaths; and one of the eight 1989, 1991 and 1992 deaths to high-rise buildings, choosing 1992 for the latter as four of the eight deaths occurred in 1992. In 1995 and 1996, deaths in facilities that care for the sick were allocated based on the high-rise share of fires. Property damage figures for apartments in 1991 are inflated by problems in handling the Oakland wildfire in the estimates. Property damage figures for office buildings are underestimated due to problems in handling some large-loss fires, such as a \$50 million California fire in 1988, a \$50 million Pennsylvania fire in 1989, the \$325 million One Meridian Plaza fire in Pennsylvania in 1991, and the \$230 million World Trade Center incident in 1993, whose more than 1,000 injuries also are not properly reflected in national estimates.

Note: These are fires reported to U.S. municipal fire departments and so exclude fires reported only to Federal or state agencies or industrial fire brigades. Fires are rounded to the nearest hundred, civilian deaths and injuries are rounded to the nearest one and direct property damage is rounded to the nearest hundred thousand dollars. Property damage has not been adjusted for inflation.

Source: National estimates based on NFIRS and NFPA survey.

taller. This report emphasizes the pivotal role of functional sprinklers in extinguishing and controlling fires, citing from an earlier NFPA survey that nearly two-thirds of high-rise apartment fires occurred in buildings without sprinklers. Hall tabulates several hundred high-rise fires from 1911 to 2001 with fatalities in his report, using the NFPA high-rise definition as being a building of 7 stories or more.

Table 7.1 reproduces Table 1 from Hall (2001) on all high-rise fire occurrences in the U.S. by year from 1985 through 1998 for four occupancy classifications:

- Apartments.
- Hotels and motels.

- Hospitals and care facilities.
- Offices.

The annual fire occurrences in such high-rise buildings range from 10,000 to 17,200 per year, with annual civilian deaths between 23 and 110, civilian injuries between 554 to 950, and direct property damage between \$24.9 million to \$150.1 million. To include the fires from other high-rise property classes and in residences with unreported heights, an increase of 33 percent is suggested by Hall, thereby increasing this annual range of actual high-rise fire occurrences in the U.S. from the range of 10,000 to 17,200 per year to the range of 13,330 to 22,900 per year.

As part of a recently completed NIST project to assess the needs and existing capabilities for full-scale fire resistance testing, Iwankiw and Beitel (2002) compiled the results of past multi-story building collapses, either partial or total, that were directly caused by fires. In this study, multi-story buildings were defined as those with 4 or more stories. A total of 22 such cases were identified, with the September 11, 2001 disasters accounting for 5 of these incidents (WTC 1, 2, 5, and 7, and the Pentagon). The cases had occurred not just in the U.S., but also internationally.

This NIST survey data demonstrated that buildings of all types of construction and occupancies, in the U.S. and abroad are susceptible to fires, particularly older buildings and those that may be undergoing construction, renovations or repairs. The fatality rate is dominated by the September 11, 2001 WTC experience, which is unique in that it was precipitated by terrorist attacks, which substantially damaged the structural framing and destroyed its fire protection systems prior to the fires.

Fortunately, fires in tall buildings do not often lead to partial or total collapse, as in these 22 documented cases. Furthermore, all of the other collapses were not nearly as catastrophic as those in the September 11, 2001 experience. More often, the fire and smoke are the cause of death in a densely occupied building. These also create significant fire damage and monumental property losses over many floors.

The 1980 fire in the unsprinklered MGM Grand Hotel in Las Vegas killed 84 people, injured another 679, and caused hundreds of millions of dollars in property damage (Clark County Fire Department, 1981). If the building is relatively vacant, or under construction, the probability of human fatalities is markedly decreased, but the resulting fire damage, even without collapse, can be significant.

Notable examples of excellent structural integrity under adverse fire conditions exist:

- The 1988 fire in the 62-story First Interstate Bank building in Los Angeles in which 4 floors burned out (Klem, 1988).
- The 1991 fire in the 38-story One Meridian Plaza building in Philadelphia in which 9 floors burned out (Klem, 1991).
- The 1991 fire in the 12-story Mercantile Credit Insurance Building in which 3 floors burned out.
- The 1990 fire in the 14-story Broadgate Phase 8 building in the U.K., which had unprotected steel beams and columns during erection (Newman et al, 2000).

Nonetheless, some casualties and major economic losses were still incurred in these steel-framed buildings. Complete burnouts of several floors destroyed the interior con-

tents and caused substantial and permanent floor sagging and steel beam distortions, as would be expected after a long and severe fire exposure. In the One Meridian Plaza building, main support beams deflected as much as 18 in., and one entire area of the 22nd floor had deformed as much as 4 to 5 ft. All of these buildings, except One Meridian Plaza, were repaired and returned to service. While One Meridian Plaza could have been returned to service, the owner chose to demolish the building and build a different combination of occupancies.

Sao Paulo, Brazil had two major high-rise fires in the 1970s in buildings that were constructed of reinforced concrete. The 1972 fire in the 31-story Andraus building (Wiley, 1972) resulted in 16 casualties, while the 1974 fire in the 25-story Joelma building (Hall, 2001) caused 189 deaths. These fires both caused severe spalling of large portions of the exterior concrete walls, joists, and columns, due to the severe fire and high temperatures, exposing the reinforcing steel. Both the Andraus and Joelma buildings remained standing, and were subsequently repaired and returned to service.

#### **7.4 Are any multi-story building materials or occupancies more susceptible to fire-induced collapses than others?**

No. Past experience and the recent NIST collapse survey (Iwankiw and Beitel, 2002) confirm that fires and the damage, deaths, and injuries they cause are rare and random events, whose effects depend not on material or occupancy but on the time, nature and circumstances of the fire occurrence. Likewise, the added fire-fighting difficulty in all taller buildings is recognized, given the longer times needed to escape or access the higher floors. Many of the past major fires in tall buildings fortunately occurred in the evenings or weekends, when the office buildings were almost vacant, hence, minimizing their potential dangers to human life.

Automatic sprinkler systems are a very effective means to control and suppress a fire, but if the system is non-existent or non-functional, the threat of fire growth increases. For example, the One Meridian Plaza building was undergoing a partial sprinkler installation upgrade at the time of its 1991 fire, and had sprinklers installed on the 30th and 31st floors. The 9-story fire, which started at the 22nd floor was halted at the first level at which sprinklers had been installed (30th floor). Quite probably, the severity of this major fire would have been radically reduced had sprinklers been installed on the 22nd floor where the fire originated.

The NIST survey of 22 fire-induced building collapses since 1970 involved a variety of conditions, materials, locations, and buildings. Fifteen cases were from the U.S., 2 from Canada, and 5 from Europe, Russia and South Amer-

ica. The numbers of fire collapse events can be categorized by building material as follows:

- 7 buildings were constructed of reinforced concrete, including the Pentagon.
- 6 buildings were constructed of structural steel, including the WTC towers and buildings 5 and 7.
- 5 buildings were constructed of brick and/or masonry.
- 2 buildings were constructed of wood.
- 2 buildings were of unknown construction.

Three of these events were from the 1970s, another 3 from the 1980s, four from the 1990s, and twelve from 2000 and beyond. This temporal distribution is skewed towards more recent occurrences, as expected, both due to the magnitude of the September 11, 2001 events, which account for 5 total.

The collapse distribution by building story height was as follows:

- 13 buildings had 4 to 8 stories.
- 3 buildings had 9 to 20 stories.
- 6 buildings had 21 or more stories.

Thus, almost 60 percent of the cases are in the 4 to 8 stories range, with the remainder affecting much taller buildings. This percentage is large even though three of the six collapses in buildings over 20 stories were from September 11, 2001.

At least four of these fire collapses had occurred during construction or renovations of some kind, when the usual expected architectural, structural and fire protection functions were still incomplete or temporarily disrupted, and/or potential new fire sources were introduced, in the construction process. Partial collapses (14 events) were the most frequent occurrences, and the WTC disasters (listed as 4 separate events, with 3 full collapses) dominated the full collapse event total of 8 cases.

Office and residential were the primary types of occupancy in these 22 buildings, as would be expected in multi-story construction, with the occupancy distribution being as follows:

- Office: 9
- Residential: 8
- Commercial: 3
- Combined commercial/residential: 2

Three examples of multi-story buildings that were not of steel construction that suffered fire-induced collapse are summarized herein. On May 21, 1987, Sao Paulo had one of the biggest fires in Brazil, which precipitated a substantial partial collapse of the central core of the tall CESP Building 2 (Berto and Tomina, 1988). This was a 21-story office building, which served as the headquarters of the Sao Paulo Power Company (CESP), after whom the building was named.

Buildings 1 and 2 of this office complex were both of reinforced concrete framing, with ribbed slab floors. Berto and Tomina reported on several unique internal features and contents, including:

- Both buildings still retained their original wood forms used for pouring the concrete floor slabs, which were never removed.
- Low-height plywood partition walls were used in the interiors.

Approximately two hours after the beginning of the fire in CESP 2, its structural core area throughout the full building height collapsed. This collapse was attributed to the thermal expansion of the horizontal concrete T-beam frames under the elevated fire temperatures, which led to the fracture of the vertical framing elements and their connections in the middle of the building, and the consequent progressive loss of gravity load-carrying capacity (see Figure 7.1).

A fire-initiated full collapse of a textile factory occurred in Alexandria, Egypt on July 19, 2000 (BBC News, 2000). This 6-story building was built of reinforced concrete, and its fire started at about 9 a.m. in the storage room at the ground floor. Fire extinguishers were non-functional, and the fire spread quickly before the firefighters could arrive. An electrical short-circuit accelerated the fire spread. At about 6 p.m., 9 hours after the start of the fire, when the



Fig. 7.1. CESP 2 Core Collapse in Sao Paulo, Brazil (Berto and Tomina, 1988)

blaze seemingly was under control and subsiding, the building suddenly collapsed, killing 27 people. Figure 7.2 shows a photograph of this collapse.

Two large department store fires in Athens, Greece in 1980 are documented by Papaioanna (1986). These fires began at 3 a.m. on December 19, 1980, with arson being suspected as the cause. The Katrantzos Sport Department Store was an 8-story reinforced concrete building. Its fire started at the 7th floor and rapidly spread throughout the building, due to lack of vertical or horizontal compartmentation and the absence of sprinklers. Collected evidence indicated that the fire temperatures reached 1,830 °F (1,000 °C) over the 2 to 3 hour fire duration, and the firefighters concentrated on containing the fire spread to the adjacent buildings. Upon termination of these fires, it was discovered that a major part of the 5th through 8th floors had collapsed. Various other floor and column failures throughout the Katrantzos Building were also observed, as shown in Figure 7.3. The cause of these failures was considered to be restraint of the differential thermal expansion of the structure that overloaded its specific elements or connections.

In summary, this recent survey of fire incidents in multi-story buildings shows that the building occupancy, material, and type of construction appear to have little, or no, correlation with actual fire occurrences, subsequent partial or total collapses, and fatalities.

### 7.5 How does the frequency and fatalities of high-rise fires compare to those in low-rise buildings?

Hall (2001) states that over 10,000 fire cases occurring annually in U.S. buildings of 7 stories or more constitute only 2 to 3 percent of all building fires in this country. Not surprisingly, of the remaining 97 to 98 percent of U.S. fires in other buildings with less than 7 stories, the largest dominant segment of fires occurs in the 1- and 2-family low-rise dwellings. Consistent with these findings is the observation



Fig. 7.2. Collapsed Textile Factory in Alexandria, Egypt (BBC New, 2000)

that civilian fatalities in the taller office and commercial buildings are significantly less than those in low-rise residences, both in absolute number and in rate per 1,000 fires. U.S. fire statistics for the latter half of the 1980s indicate that there were about 8½ deaths per 1,000 fires in 1- and 2-family dwellings versus 1 death per 1,000 fires in office buildings (Bennetts et al, 2000).

Therefore, past data shows that uncontrolled fires in the taller office buildings are infrequent compared to those in low-rise residences. Furthermore, the fatalities and the fatality rate per fire are much less in office buildings, probably due to their minimum occupancy at nights and the presence of automatic sprinklers and fire detection/alarm systems.

### 7.6 Of all the various building fire protection and safety measures, which one(s) are the most effective?

Thomas (2002) reviewed the historical U.S. fire statistics to analyze the relative effectiveness of the three primary components of fire safety strategies in buildings:

- Sprinklers
- Detectors
- Fire-protected construction



Fig. 7.3. Katrantzos Department Building in Athens, Greece, After 1980 Fire (Papaioanna, 1986)

A variety of fire data is evaluated and presented in this paper. The author's conclusions are:

*“Based on the extent of flame damage in Figure 2 for all occupancies, it is generally better (and never significantly worse) to have sprinklers alone than to have both detectors and protected construction. In all occupancies, there was an advantage (sometimes very small) in having sprinklers plus detectors plus protected construction compared with sprinklers alone.*

*The limited data available makes it possible only to estimate the effectiveness of three fire safety measures: sprinklers, detectors, and protected construction. Data on a greater range of components and sub-systems would be very beneficial in that it would enable their effectiveness to be estimated also.*

*Based on the data analyzed, it appears that sprinklers are generally more effective in reducing fire spread and to a lesser extent civilian fatalities, firefighter injuries and property losses than either detectors, protected construction or both detectors and protected construction.”*

The implications of this study and its practical consequences for future fire safety requirements are potentially enormous. Thomas (2002) and Hall (2001) establish based on historical fire data that functional automatic sprinkler systems are the best, and most effective, means to provide for building fire safety. Early fire suppression is the optimum strategy for fire safety and protection, as discussed in Section 1.

#### **7.7 How reliable are automatic sprinkler systems?**

While nothing is absolutely failsafe, historic fire performance data indicates that automatic sprinkler systems have proven to be exceptionally effective and reliable when properly designed, installed and maintained, as indicated previously in both Sections 1.5 and 7.6. Sprinklers limit both fire growth and smoke generation. No other approach or combination thereof has demonstrated a comparable effectiveness in reducing loss of life due to fire.

# Section 8

## SPECIAL STEEL FIRE RESISTANCE ISSUES AND FUTURE NEEDS

### 8.1 What is the difference between prescriptive and performance-based design for fire safety?

Prescriptive code criteria have been in place for decades in the U.S., and in other countries, to provide for building fire resistance, and other fire prevention and protection measures. As the name implies, these are the explicit requirements that state when, where, and how much of certain features and products are required. The redundancy and robustness of traditional fire protection systems installed in buildings as required by the building codes have always relied on some combination of compartmentalization with both horizontal and vertical separations, fire-resistive treatments of the structural systems, detection, and suppression.

In the area of building fire resistance, the prescriptive criteria have almost universally been based on the ASTM E119 ratings derived from standard fire tests. The nature of most of these prescriptive methods has been summarized previously in Sections 2 through 5. Sometimes, this approach is characterized as “deemed to comply”, which means it is considered compliant because it meets the detailed characteristics required and satisfies the stated limitations of intended safety function(s) of the building code.

In contrast, performance-based design is predicated on a more open-ended statement of the final performance objectives of the system. The precise details and methodology on how these general performance goals will be met are determined by the responsible professional, in accordance with the available state of the art, and subject to the acceptance of the building code official. This process usually involves a more detailed modeling analysis and computational design of the fire resistance and protection system than is directly covered by the codes and standards. Many times, this approach is based upon testing confirmatory testing. It is expected that because of the potential complexity of the issues, alternative means and methods and their justification, a greater reliance on technical peer review will be placed.

Thus, the performance-based design option consists of a set of defined performance goals and objectives, along with related criteria for an expected fire event. In some cases, the performance design includes an evaluation of design alternatives against a set of real fire design scenarios, not standard fires. Additionally, it usually involves more elaborate thermo-structural analyses. A corresponding set of features, systems and design solutions must be developed with suffi-

cient documentation to demonstrate to the building code official, or designated peer reviewer, that the minimum goals and objectives of the building code are satisfied.

### 8.2 How prevalent is performance-based fire design? Where can one find more information on this approach?

Performance-based design is still only an emerging design option in the U.S. Its use to date has been for notable projects in which the exposures were considered critical or complicated in terms of fire safety. Thus, it is a potentially attractive, and perhaps more accurate, special design alternative to the more prevalent prescriptive design methodology for routine applications.

ASCE and SFPE are jointly developing the first U.S. standard on performance-based fire design. This draft document remains in committee with additional work and reviews pending, and is not yet available to the public. The two national model building codes in the U.S. offer performance-based design alternatives in the following documents:

- NFPA 5000, *Building Construction and Safety Code*, National Fire Protection Association (NFPA), Quincy, MA, 2002
- *ICC Performance Code for Buildings and Facilities*, International Code Council (ICC), 2003

Other countries are seemingly advancing to performance-based design for fire at a faster pace, both in terms of the published design standards and related references, and the number of such project applications. Two excellent modern references from the European community on performance-based fire design are:

- *Model Code on Fire Engineering*, European Convention for Constructional Steelwork (ECCS), Technical Committee 3, First Edition, May, 2001, No. 111, Brussels, Belgium
- *Rational Fire Safety Engineering Approach to Fire Resistance in Buildings*, CIB W014, Publication 269, International Council for Research and Innovation in Building Construction: free download available from CIB Website at

<http://www.cibworld.nl:600/pages/ftp/CIB269.pdf>

In addition to these, several excellent comprehensive textbooks are available on this subject, such as the two more recent ones given below:

- Buchanan, Andrew, H, *Structural Design for Fire Safety*, John Wiley & Sons, Ltd., 2001
- Wang, Y.C., *Steel and Composite Structures: Behaviour and Design for Fire Safety*, Spon Press, 2002

Baker et al (1996) describes several innovative fire engineering solutions in major European buildings that permitted the use of exposed exterior structural steel. These projects by the office of Skidmore, Owings, and Merrill were the Broadgate Exchange House in London, England, One Ludgate Place, also in London, and the Hotel Arts in Barcelona, Spain.

Even though the use of performance-based fire design in the U.S. is an exception, rather than the rule, a number of notable projects have also been designed and built using some of these more advanced fire-engineering concepts. A few of the more unique domestic projects in this regard include:

- One Liberty Plaza, New York, which utilized flame shielding of exterior steel.
- Great Platte River Bridge, Nebraska, which utilized flame shielding of exposed steel.
- John Deere Building, Moline, IL, which utilized flame shielding.
- U.S. Steel Building, Pittsburgh, PA, which utilized water-filled HSS columns

The design standards and code community in the U.S., including organizations such as AISC, SFPE, ASCE, NFPA, and ICC, is still in the process of further developing similar types of information, documents and references for wider use in this country. In particular, the 2005 AISC Specification is expected to contain a completely new section on methods for engineered structural fire protection design for steel buildings. There are also wider discussions underway within the engineering community on adding fire as a regular design load to the structural system. Traditional structural design practices require a direct evaluation of applied loads caused by gravity, wind, seismic, impact and hydrostatic/hydrodynamic forces.

### 8.3 What full-scale fire tests been performed on steel-framed open-deck parking structures and with what outcomes?

There is a considerable record of full-scale automobile burn-out fire tests in open-deck parking structures going back over thirty years with tests performed in Britain

(1968), Switzerland (1969, 1970), Japan (1970), U.S. (1972), Australia (1985), and France (2000). The results are all the same:

- The passenger automobile is not a significant fire hazard in an open-deck parking structure built from noncombustible materials.
- Fire in an open-deck parking structure does not lead to significant structural damage.
- There is no need to protect the steel frame of an open parking structure.

Statistical and anecdotal records of real-life fires in non-combustible parking structures, such as steel, confirm these conclusions. An open parking garage is defined more exactly in the building codes, but it essentially contains uniformly distributed and substantial openings in both its exterior and the interior walls, and with no compartmentalization on each floor.

The 1972 steel parking garage test in Scranton, PA shown in Figure 8.1 (Gewain, 1973) resulted in a maximum-recorded temperature in the exposed and unprotected steel girder, a cover-plated W24 × 76, of only about 440 °F (227 °C) after about 45 minutes of fire exposure to the burning cars, after which the fires and temperatures subsided. On this basis, and the other more recent burnout tests in Australia and France that produced similar results, it can be concluded that open-deck parking structures represent an extremely low fire hazard, and that exposed steel framing provides an adequate degree of fire safety against structural collapse.

The building codes commonly recognize this fact, and allow unprotected steel construction in open-deck parking structures within a range of prescribed heights and areas.



Fig. 8.1. Burning Automobile After 24 Minutes in 1972 Scranton Fire Test of Parking Garage (Gewain, 1973) (*Modern Steel Construction*, 1973)

#### 8.4 What about the fire resistance of unprotected steel in outdoor sports stadia?

The real world experience with large outdoor assembly structures, such as sports stadia and racetracks, has been similar to that with open-deck parking structures. Hughes Associates, Inc. (1988) provides a historical survey of existing outdoor sports facilities, which revealed that there were no fires reported in noncombustible construction that had resulted in a loss of life. The major reported fires with resulting deaths occurred in either mixed or combustible construction that had some additional contributing code-safety issues.

For example, the 1985 Arlington Park Racetrack fire in the suburbs of Chicago, IL destroyed this combined construction that included wood deck on unprotected steel roof members, and floors and ceilings, which were largely of combustible materials. This fire originated in concealed spaces, which were inadequately fire-stopped to prevent fire propagation.

Sports stadia present a unique occupancy that, though involving potentially large numbers of people, is properly designed to handle the movements of big crowds in an orderly fashion. The structural members in such stadia are relatively massive and rather distant from any possible normal fuel sources and flames. This situation consequently presents a relatively low fire hazard to the structure. Such a condition or exposure is similar to the typical code allowances for unprotected steel roof structures that are at a certain height (a minimum of 20 ft) above the next lower occupied level.

Aside from the critical need for noncombustible framing construction, the emphasis has been placed on fire prevention, detection, and suppression measures within the accessory uses of the facility (concession stands, souvenir shops, restaurants) as being much more effective for fire safety reasons.

Consequently, most building codes continue to allow unprotected steel-framed construction for outdoor sports stadia either as a separate occupancy, or with the exclusion of the usual building height and area restrictions. Some recent prominent steel structures of this type include Safeco Field in Seattle, Coors Field in Denver, and Camden Yards in Baltimore. Wrigley Field in Chicago and Fenway Park in Boston are two of the old historic steel sports arenas that have successfully operated for almost a century without the occurrence of well-developed fires.

#### 8.5 Can exposed and unprotected steel also be used in various transportation structures?

Yes. It has been traditional and successful practice to use unprotected structural steel in such transportation facility applications as elevated train structures and stations, as well

as subway tunnels and stations. This historical empirical evidence was first compiled by Rolf Jensen & Assoc. and Schirmer Engineering Corp. (1981).

The basis for this practice is the assumed use of noncombustible construction such as steel, wherein the actual risk to people of a fire-induced structural collapse is quite limited, both due to the nature of the normally limited fuel sources and to the possibility for quick emergency evacuation of the people. By rational extension, this conclusion has also been applied to highway, rail, and road bridges. Also implicit in this approach is that the responsible law-enforcement, regulatory, and security authorities will adequately monitor and control the routes of any unusually hazardous cargo in trains, trucks, buses, or cars, which may not only expose the transportation system to increased risks in the event of an accident or sabotage, but also likewise affect general public safety.

Therefore, codes and standards, such as NFPA 130, *Standard for Fixed Guideway Transit and Passenger Rail Systems*, allow for the use of unprotected steel in such transportation structures and systems.

#### 8.6 When can unprotected steel be used in other exterior applications in buildings?

An analytical method is available and can be effectively used to determine when unprotected steel is acceptable for building exteriors. The popularity of architecturally exposed steel has been increasing, given the inclination of many notable architects to aesthetically express the structural form of the building in this way. The justification for such use of exposed steel without any fire protection is based on the evaluation of the potential temperature increase in the exterior steel due to a fire inside the building, including any shielding effects, with the flames impinging on the exterior exposed steel through the window openings and transferring heat by radiation (see Figure 8.2).

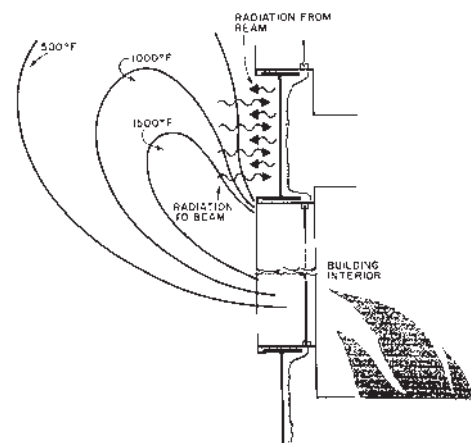

Fig. 8.2. Typical Exterior Heat Radiation Temperatures Developed from Interior Building Fire (AISI, 1979)



This methodology (AISI, 1979) involves the calculations of burning combustibles in rooms adjacent to the exterior walls, intensity and rate of burning in a room, the flame exposure outside of the windows, flame impingement on the exposed structural steel members, and finally, the resulting temperatures in the outside steel. The typical flame shapes and fire radiation configurations for the basic conditions of forced draft and without forced draft are illustrated in Figure 8.3. Three different possible column locations are shown that each require correspondingly different analyses, with column C having the least severe fire exposure from the window opening. If the resulting computed steel temperature is less than a critical temperature of 1,000 °F (537 °C), the design is considered to be adequate for fire safety. Positioning of appropriate supplemental flame shielding may be helpful to prevent more direct flame impingement on exterior load-carrying members. A more current and readily available reference for this analysis procedure is available (ECCS, 2001).

A number of actual projects designed with this methodology are listed in Section 8.2. Sometimes, a building owner or building code official will require additional fire test verification of these analyses, particularly for larger landmark structures.

### 8.7 How can flame shielding and the use of water-filled columns serve as fire protection?

The principle of flame shielding relies on providing a physical barrier to the direct flame impingement on the structural member that is to be considered fire resistive. Figure 8.2 schematically illustrates how the exterior radiation heat temperature contours are lower the farther they are from the direct fire source inside of the building. Thus, the flame shield through and around the window opening serves as a

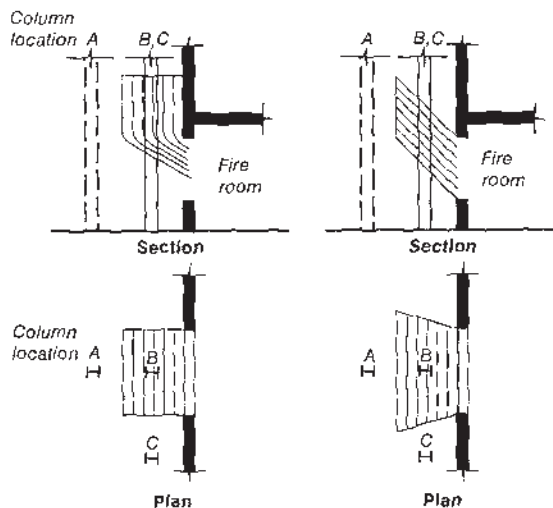

Fig. 8.3. Exposed Exterior Steel Columns in a Building Fire, Without and With Through Draft (AISI, 1979)

sacrificial element that not only protects the member from exposure to the hotter fire temperatures, but also provides some air/distance separation between the fire and the member, which is well known to be beneficial in moderating the temperature rise in the structural member itself. The flame-shielding concept was successfully used to protect exposed spandrel steel beams in the 54-story One Liberty Plaza building in New York City, among others.

Another innovative method that is possible, but used much less frequently, is water-cooled hollow structural section (HSS) columns. As shown in Figures 8.4 and 8.5, this concept depends on hydraulics and thermodynamics in the circulation of cold water within the steel columns when exposed to a fire. The mechanism provides a continuous heat sink to the fire exposures in the form of the circulating water, or another liquid, within the columns, which keeps the steel itself cool enough to avoid strength and stiffness degradation. Such liquid-filled columns theoretically, and under idealized circumstances, can maintain unlimited fire resistance, as long as the liquid supply and circulation is maintained. This system also requires that the liquid in the columns contain a rust inhibitor, and in the cold-weather regions, an anti-freeze agent, and perhaps some other additives to avoid biological stagnation and growth of microorganisms in the water supply.

The 64-story U.S.X (U.S. Steel) building in Pittsburgh was the first building in the U.S. to employ water-filled HSS columns in 1970. Several other buildings in the U.S., and worldwide, have also successfully used this concept. The

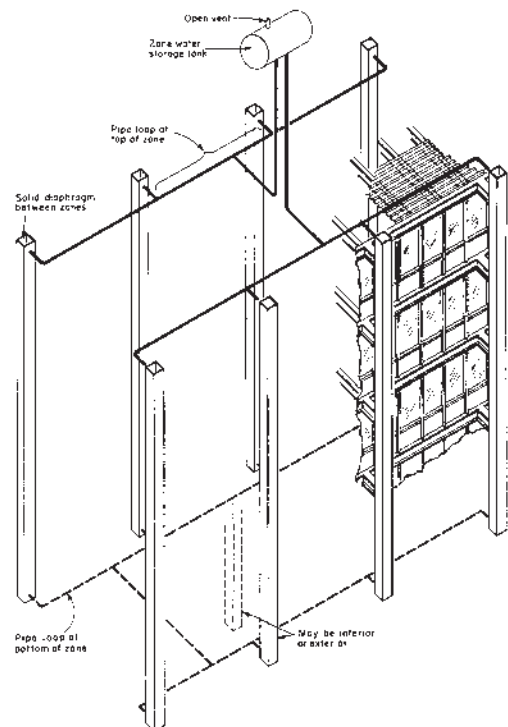

Fig. 8.4. Schematic Layout of Typical Piping in a Liquid-filled Column Fire Protective System (AISI, 1981)

initial design cost and necessity to maintain a functional mechanical piping network in this way, without leakage, freezing, and steel corrosion, are the potential difficulties, and risks, with this fire protection method, which would usually not be considered a passive protection system, such as SFRM, gypsum, or concrete. The nature of liquid-filled columns more resembles the active features provided by automatic sprinklers, though the latter is a fire suppression measure. Its past actual building usage has been good without reported problems.

### 8.8 What are some of the future research needs and directions for steel fire resistance design?

If what is occurring elsewhere internationally is a valid precursor, then performance-based design for fire will eventually also become a reality in the U.S., thereby leading to more frequent application of these more advanced fire engineering principles. The September 11, 2001 disaster, and the many remaining questions about the significance and role of these fires in these building collapses, is likely to accelerate this progress. The NIST investigation, research, and technology transfer on their multi-year, post-WTC project is expected to be the strong catalyst for such, working in harmony with the other participating professional, industry, and code organizations, including AISC.

However, before U.S. fire engineering practice reaches this higher order level of fire design on a more regular frequency, much more development work is still needed. A better definition and classification of the real fire loads for different building occupancies needs to be standardized in a user-friendly format, and the various thermo-structural analyses tools and related design aids need to be more fully developed and validated. The fire performance of structural connections and splices needs to be better understood. Some of this information can be imported directly from the current overseas knowledge base in this field, but the necessary fire design verification, calibration and simplification work yet remains to be done domestically. Finally, of course, the U.S. building codes and standards need to document and adopt these modern techniques as possible alternatives to the traditional prescriptive methods for fire protection.

In terms of basic fire research needs, several key issues exist, most of which have been identified and emphasized (FEMA, 2002):

- Durability and adhesion of lower density SFRM to steel, including effects of impacts, dynamic motions, and large deflections
- More accurate thermal (temperature-dependent) properties of SFRM and other protection materials

- Performance of connections in a fire, including the secondary catenary action mechanism
- Performance of building framing, and its larger sub-assemblies, in a fire
- Effects of extreme combination of events, involving fire with a structurally damaged frame and/or with other impaired fire protection systems
- Extent of adequacy of fire ratings derived from the ASTM E119, and similar, fire standards
- Development of design fires
- Better integration of fire resistance with other fire safety measures

It is anticipated that these topics, which are germane not only to steel, but to all building materials, will be appropriately addressed over the next several years and resolved in the near term.

### 8.9 What is the underlying motivation, and related benefits, in moving towards the more advanced, performance-based fire engineering methods?

The main justification for this eventual transition is simply that the deterministic factor of safety, and its counterpart reliability index for probabilistic limit states design are simply unknown for the individual elements, assemblies and actual construction that were derived from the fire ratings of the ASTM E119 test standard. While generally and qualitatively, it can be said that there have not been major safety problems with these traditional prescriptive fire ratings, a

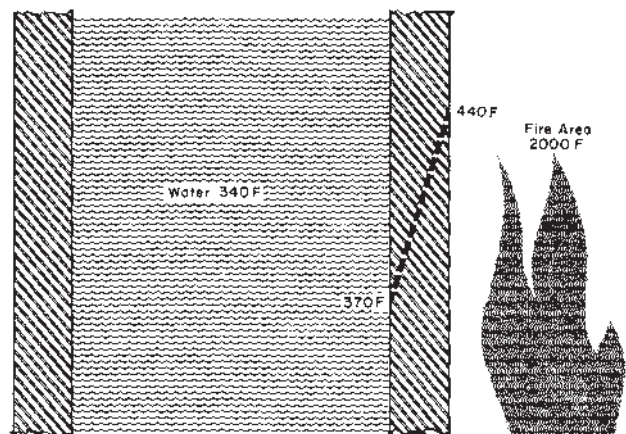

Fig. 8.5. Representative Temperature Variations in Cross-Section of Liquid-filled Steel HSS Column (AISI, 1981)

quantitative answer on how safe these ASTM E119 ratings really are depends on the real fire exposure(s) and the in-place building conditions. Such a fire resistance safety margin determination cannot currently be made for most cases, because ASTM E119 provides only a comparative empirical rating relative to other individual members or assemblies, and not an absolute index for the actual building conditions. Certainly, the safety margin for not just the many ordinary fire exposures in predefined occupancies, but also the less frequent, non-routine demands, such as those encountered on September 11, 2001, just cannot be accurately assessed with only these standard fire ratings. Thus, performance-based fire design will offer a much broader and sounder technical basis on which to both calibrate prescriptive ratings for the common exposures, and to develop any needed special requirements for the unusual conditions given some target safety margin, or probability of non-exceedance (or time return period for an event).

As mentioned before, structural design involves proportioning framing and connections to resist the expected loads. The primary load types currently recognized are gravity (dead, live, rain, snow), wind and seismic. In addition, ASCE 7 has now included a suggested load combination with an extreme fire event in an Appendix, which specifies the building's full factored dead load and 50 percent of the gravity live load to be acting during the fire. Such an established structural loading requirement with fire is one of the main ingredients to enable performance-based design, and provides a rational, and natural, basis on which to further proceed to evaluate levels of fire resistance safety.

Within such a performance-based design approach, not just the passive fire resistance, but also the entire protection system, can be quantitatively engineered for overall reliability given a certain exposure(s). This would conceivably also include the performance of sprinklers, alarms and detection devices, egress, and fire barriers to provide a more accurate overall assessment of building fire safety.

Performance-based design will entail more initial engineering time and fees to properly conduct than what is customarily done by the architect today for the popular and easy prescriptive methods. However, it is expected that this increased engineering cost will be justified in long-term building performance, and potentially in some life-cycle cost-saving benefits that performance-based fire design is anticipated to produce. Nevertheless, as with many other design innovations, it is realistically expected that the emergence of newer engineering fire design methods will also take appreciable time and effort to reach an adequate level of maturation and wider acceptance as an alternative. In the meantime and for the foreseeable future, prescriptive fire resistance criteria will probably remain a convenient and practical option.

# REFERENCES

- AISC Manual of Steel Construction (2001), *Load and Resistance Factor Design*, 3rd Edition, 2001, AISC, Chicago, IL.
- AISI (1979), *Fire-Safe Structural Steel, A Design Guide*, Washington, DC, March, 1979.
- AISI (1981), *Fire Protection Through Modern Building Codes*, 5th Edition, Washington, DC.
- ASCE Manual and Reports on Engineering Practice No. 78 (1992), Lie, T.T., Editor, *Structural Fire Protection*, American Society of Civil Engineers, New York, NY, 1992.
- ASCE-SEI (2003), *The Pentagon Building Performance Report*, American Society of Civil Engineers-Structural Engineering Institute, Reston, VA, January, 2003.
- ASCE/SFPE 29-99 (1999), *Standard Calculation Methods for Structural Fire Protection*, Structural Engineering Institute of the American Society of Civil Engineers, Reston, VA, (1999).
- ASTM E 84, *Standard Test Method for Surface Burning Characteristics of Building Materials*, American Society for Testing and Materials, West Conshohocken, PA.
- ASTM E119, *Standard Test Method for Fire Tests of Building Construction and Materials*, American Society for Testing and Materials, West Conshohocken, PA.
- ASTM E 136, *Standard Test Method for Behavior of Materials in a Vertical Tube Furnace at 750 °C*, American Society for Testing and Materials, West Conshohocken, PA.
- ASTM E 605, *Standard Test Methods for Thickness and Density of Sprayed Fire-Resistive Material Applied to Structural Members*, American Society for Testing and Materials, West Conshohocken, PA.
- ASTM E 736, *Standard Test Method for Cohesion/Adhesion of Sprayed Fire-Resistive Materials Applied to Structural Members*, American Society for Testing and Materials, West Conshohocken, PA.
- ASTM E 759, *Standard Test Method for Effect of Deflection on Sprayed Fire-Resistive Material Applied to Structural Members*, American Society for Testing and Materials, West Conshohocken, PA.
- ASTM E 760, *Standard Test Method for Effect of Impact on Bonding of Sprayed Fire-Resistive Material Applied to Structural Members*, American Society for Testing and Materials, West Conshohocken, PA.
- ASTM E 761, *Standard Test Method for Compressive Strength of Sprayed Fire-Resistive Material Applied to Structural Members*, American Society for Testing and Materials, West Conshohocken, PA.
- ASTM E 859, *Standard Test Method for Air Erosion of Sprayed Fire-Resistive Materials Applied to Structural Members*, American Society for Testing and Materials, West Conshohocken, PA.
- ASTM E 937, *Standard Test Method for Corrosion of Steel by Sprayed Fire-Resistive Material Applied to Structural Members*, American Society for Testing and Materials, West Conshohocken, PA.
- ASTM E 1529, *Standard Test Method for Determining Effects of Large Hydrocarbon Pool Fires on Structural Members and Assemblies*, American Society for Testing and Materials, West Conshohocken, PA.
- Bailey, C.G. (2001), “Steel Structures Supporting Composite Floor Slabs: Design for Fire”, Building Research Establishment, 2001, BRE Digest 462.
- Baker, W., Iyengar, H., Johnson, R., and Sinn, R. (1996), “Bare Bones Buildings”, ASCE Civil Engineering Magazine, 1996.
- BBC News (2000), “Factory Fire Kills 15 in Egypt”, World: Asia-Pacific, July 20, 2000.
- Bennetts, I.D., Goh, C.C., Thomas, I.R., Poh, K.W. (2000), “Low-Rise Office Construction—A Guide for Fire Safety”, One Steel Market Mills, Newcastle, Australia, November, 2000.
- Berto, Antonio Fernando and Tomina, Jose Carlos (1988), “Lessons From the Fire in the CESP Administration Headquarters”, IPT Building Technologies, 1988, Sao Paulo, Brazil.
- Buchanan, Andrew, H. (2001), “Structural Design for Fire Safety”, John Wiley & Sons, Ltd., 2001.
- CIB W014, Publication 269, “Rational Fire Safety Engineering Approach to Fire Resistance in Buildings”, International Council for Research and Innovation in Building Construction.
- Clark County Fire Department (1981), “The MGM Grand Hotel Fire Investigation Report”, 1981, Clark County, Nevada.
- Dill, F.H. (1960), “Structural Steel After a Fire”, *Proceedings of National Steel Construction Conference*, May 5-6, Denver, CO, AISC, Chicago, IL, 1960.

- European Convention for Constructional Steelwork (ECCS), (1983), *European Recommendations for the Fire Safety of Steel Structures*, ECCS-TC-3, 1983, Elsevier.
- European Convention for Constructional Steelwork (ECCS), (2001) *Model Code on Fire Engineering*, Technical Committee 3, First Edition, May, 2001, No. 111, Brussels, Belgium.
- FEMA (2002), FEMA 403 *World Trade Center Building Performance Study: Data Collection, Preliminary Observations, and Recommendations*, Federal Emergency Management Agency, Washington, DC, May, 2002.
- Gann, R.G., Babrauskas, V., Peacock, R.D., and Hall, J.R. (1994), "Fire Conditions for Smoke Toxicity Measurement", *Fire and Materials*, 18(3), May-June 1994, pp 193-199.
- FM (Factory Mutual) Approval Guide, FM Approvals, Norwood, MA 2002.
- Gewain, R.G., and Troup, E.W.J. (2001), "Restrained Fire Resistance Ratings in Structural Steel Buildings", *AISC Engineering Journal*, Second Quarter, 2001, AISC, Chicago, IL.
- Gewain, R. G. (1973), "Fire in an Exposed Steel Parking Structure", *AISC Modern Steel Construction*, First Quarter, 1973, AISC, Chicago, IL.
- Gypsum Association (2000), *Fire Resistance Design Manual*, 2000, Washington, DC.
- Hall, John R, Jr. (2001), "High-Rise Building Fires", September, 2001, NFPA, Quincy, MA.
- Hughes Associates, Inc., (1988), *Fire Safety Survey of Large Outdoor Structures*, Report for AISI, Aug., 1988, Wheaton, MD.
- Ingberg, S.H. (1928), "Tests of the Severity of Building Fires", *Quarterly*, National Fire Protection Association, Vol. 42, 1928.
- International Code Council (2003), *International Building Code*, Falls Church, VA, 2003.
- International Standards Organization (ISO) 834, *Fire Resistance Tests—Elements of Building Construction*, ISO, Switzerland.
- Iwankiw, N. and Beitel, J. (2002), "Analysis of Needs and Existing Capabilities for Full-Scale Fire Resistance Testing", Hughes Associates, Report NIST GCR 02-843, December, 2002.
- Klem, Thomas J. (1988), "First Interstate Bank Building Fire, Los Angeles, CA, May 4, 1988", NFPA Fire Investigation Report, Quincy, MA.
- Klem, Thomas, J. (1991), "One Meridian Plaza, Philadelphia, PA, Three Fire Fighter Casualties, February 23, 1991", NFPA Fire Investigation Report, Quincy, MA.
- Kodur, V. K. R. and MacKinnon, D. H. (2000), "Design of Concrete-Filled Hollow Structural Steel Columns for Fire Endurance", *AISC Engineering Journal*, First Quarter, 2000, pp. 13-24, AISC, Chicago, IL.
- National Institute of Building Sciences (NIBS), (2000), *Guideline on Fire Ratings of Archaic Materials and Assemblies*, 2nd Ed., Washington, DC, 2000.
- Newman, G.M., Robinson, J.F., and Bailey, C.G. (2000), "Fire Safe Design: A New Approach to Multi-Storey Steel-Framed Buildings", Steel Construction Institute, Berkshire, U.K., 2000.
- NFPA 130, *Standard for Fixed Guideway Transit and Passenger Rail Systems*, National Fire Protection Association, Quincy, MA.
- NFPA 259, "Test Method for Potential Heat of Building Materials", National Fire Protection Association, Quincy, MA,
- NFPA 5000, *Building Construction and Safety Code*, National Fire Protection Association (NFPA), Quincy, MA, 2003.
- Omega Point Laboratories Inc., *Directory of Listed Building Products, Materials and Assemblies*, Volume II, Elmendorf, TX, 2002, (updated annually).
- Papaioannoa, Kyriakos, (1986), "The Conflagration of Two Large Department Stores in the Centre of Athens", *Fire and Materials*, Vol. 10, 1986, pp. 171-177, John Wiley and Sons, Ltd.
- Rohr K. D., (2001), "U. S. Experience with Sprinklers", National Fire Protection Association, Quincy, MA, September, 2001.
- Rolf Jensen & Assoc. and Schirmer Engineering Corp. (1980), "Fire Experience and Exposure in Fixed-Guideway Transit Systems", AISI Report, December, 1980.
- SFPE Handbook of Fire Protection Engineering* (2002), by the Society of Fire Protection Engineers (SFPE), 3rd Edition (2002), Bethesda, MD.
- Smith, C.I., Kirby, B.R., Lapwood, D.G., Cole, K.J., Cunningham, A.P., and Preston, R.R. (1981), "The Reinstatement of Fire Damaged Steel Framed Structures", *Fire Safety Journal*, 4 (1981), pp. 21-62, Elsevier.
- Thomas, I.R. (2002), "Effectiveness of Fire Safety Components and Systems", *Journal of Fire Protection Engineering*, Vol. 12, May, 2002, Society of Fire Protection Engineers, Bethesda, MD.

- Tide, R. H. R. (1998), "Integrity of Structural Steel After Exposure to Fire", *AISC Engineering Journal*, First Quarter, 1998, pp. 26-38, AISC, Chicago, IL.
- Underwriters Laboratories Inc. (2002), *Fire Resistance Directory*, Volume I, 2002, Northbrook, IL.
- UL 263, *Standard for Fire Tests of Building Construction and Materials*, Underwriters Laboratories Inc. Northbrook, IL.
- UL 1709, *Standard for Rapid Rise Fire Tests of Protection Materials for Structural Steel*, Underwriters Laboratories Inc. Northbrook, IL.
- Wang, Y.C. (2002), "Steel and Composite Structures: Behaviour and Design for Fire Safety", Spon Press, 2002.
- Wildt, Roger (1980), "Repair of Steel Structures After a Fire", AISI Technical Committee No. 8, Fire and Blast Discussion No.4, 1980.
- Willey, Elwood A. (1972), "High-Rise Building Fire, Sao Paulo, Brazil", *NFPA Fire Journal*, Quincy, MA, July 1972, pp. 6-13, 105-109.



structural steel: the material of choice

American Institute of Steel Construction, Inc.  
One East Wacker Drive, Suite 3100  
Chicago, IL 60601-2000

312.670.2400 [www.aisc.org](http://www.aisc.org)

F019-03  
(10/03:5M:XX)