

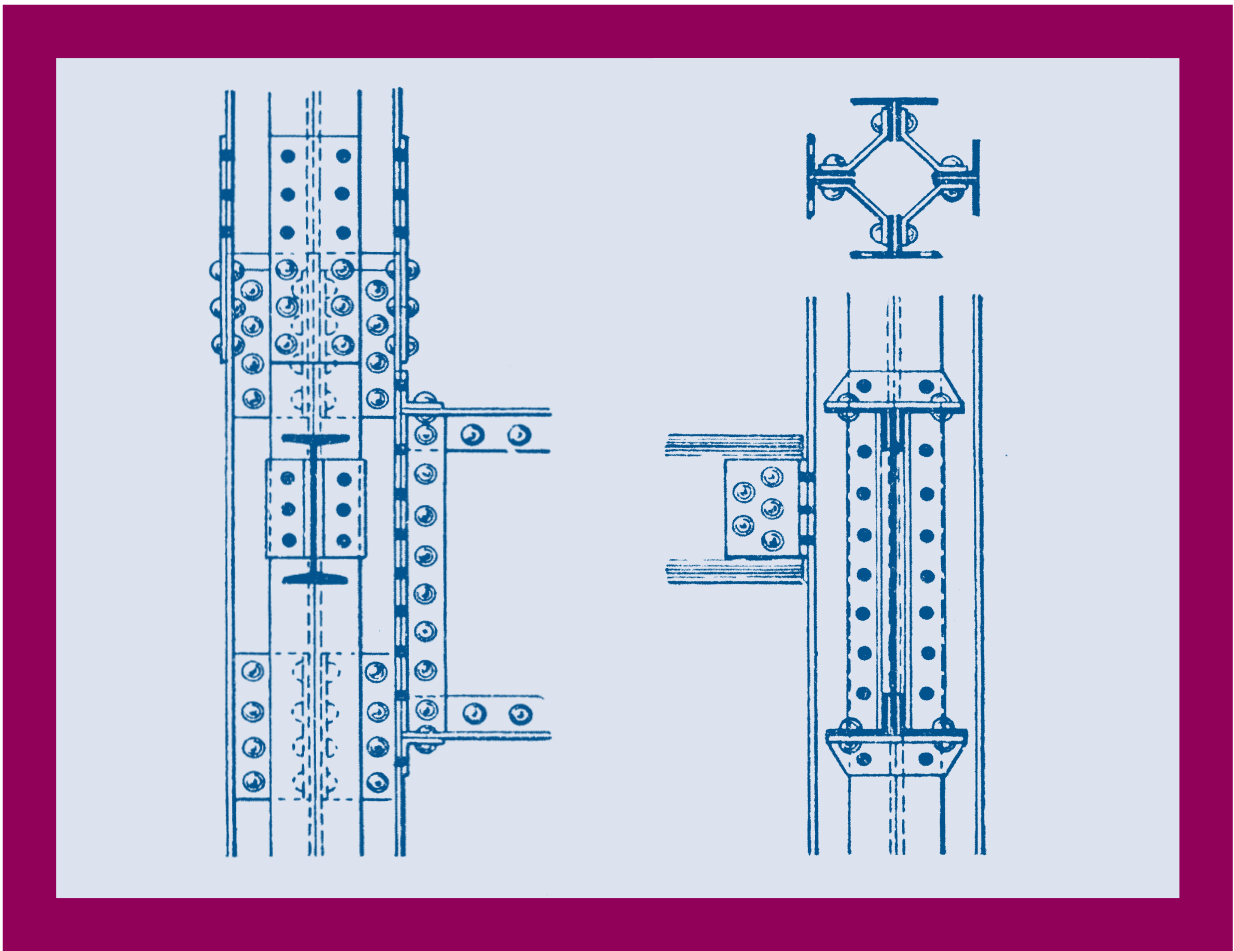

15

Steel Design Guide Series

AISC Rehabilitation and Retrofit Guide *A Reference for Historic Shapes and Specifications*





15
Steel Design Guide Series

AISC Rehabilitation and Retrofit Guide

A Reference for Historic Shapes and Specifications

Roger L. Brockenbrough, PE
R. L. Brockenbrough & Associates, Inc.
Pittsburgh, PA

Copyright © 2002

by

American Institute of Steel Construction, Inc.

*All rights reserved. This book or any part thereof
must not be reproduced in any form without the
written permission of the publisher.*

The information presented in this publication has been prepared in accordance with recognized engineering principles and is for general information only. While it is believed to be accurate, this information should not be used or relied upon for any specific application without competent professional examination and verification of its accuracy, suitability, and applicability by a licensed professional engineer, designer, or architect. The publication of the material contained herein is not intended as a representation or warranty on the part of the American Institute of Steel Construction or of any other person named herein, that this information is suitable for any general or particular use or of freedom from infringement of any patent or patents. Anyone making use of this information assumes all liability arising from such use.

Caution must be exercised when relying upon other specifications and codes developed by other bodies and incorporated by reference herein since such material may be modified or amended from time to time subsequent to the printing of this edition. The Institute bears no responsibility for such material other than to refer to it and incorporate it by reference at the time of the initial publication of this edition.

Printed in the United States of America

First Printing: February 2002

Second Printing: October 2003

Author

Roger L. Brockenbrough, P.E. is an engineering consultant working in the areas of product design and the development of technical information to facilitate improved steel designs. Formerly he was a Senior Research Consultant for U. S. Steel, involved in research studies on bridge girders (heat curving), pressure vessels, laminar imperfections, bolted connections (weathering steel), connections in HSS, and cold-formed steel. He is the author of numerous technical

papers, is the editor of two current McGraw-Hill books, *Structural Steel Designer's Handbook* and *Highway Engineering Handbook*, and contributor to a third, *Standard Handbook for Civil Engineers*. He is a member of the AISC Specifications Committee (Chair of the Materials Subcommittee) and Chair of the AISI Committee on Specifications for the Design of Cold-Formed Steel Structural Members.

Preface

The use of ferrous metal for structural framing began with cast-iron columns and wrought-iron beams. Early uses of cast iron in England in the 1770s included a small arch bridge over the river Severn at Coalbrookdale, and interior structural members in St. Anne's Church in Liverpool. In the United States, cast-iron columns were introduced as balcony supports in the Chestnut Street Theater in Philadelphia in 1820. An early use of wrought iron was in the Menai Bridge in Wales in 1826. In the United States, a wrought iron frame was used in 1853 to construct the six-story Cooper Union Building. Wrought iron appears to have flourished in the U.S. between 1870 and 1900. Structural steel shapes became available in 1880s and rapidly displaced cast iron and wrought iron. The ten-story Home Insurance Co. building erected in 1884 was the first to use steel framing. In this transitional structure, steel was used for the top four floors, wrought iron was used for the lower floors, and cast iron columns were used in the exterior walls. The advantages structural steel offered in strength, stiffness, and economy, greatly accelerated the development of tall buildings and other structures.

Chapter 1 provides a historical review of the material standards published by the American Society for Testing and Materials (ASTM) for structural steel shapes and plates, steel pipe and hollow structural sections, rivets, and bolts,

beginning in 1900. A review is also provided of the basic design stresses for structural steel, rivets, bolts, and welds, based on AISC specifications from 1923 forward.

Chapter 2 includes reference data (cross-sectional dimensions and properties) for steel shapes (wide-flange or I-shaped cross-sections) that have been discontinued over the past 125 years or so. Similar data is included for wrought iron cross-sections, which were phased out in about 1900.

Chapter 3 outlines considerations in the evaluation of existing structures for gravity loads, wind loads or seismic loads. Chapter 4 describes how existing structural systems can be enhanced for increased strength and stiffness. An extensive list of references on rehabilitation and retrofit is given in Chapter 5 along with a summary of their contents.

This design guide is concluded with a set of appendices that provide a detailed review of AISC Specification changes beginning in 1923, a tabulation of AISC Manuals published beginning in 1927, a summary of changes in specifications for high-strength bolted joints beginning in 1951 (as developed by the Research Council on Structural Connections (RCSC) and its forerunner), and a summary of design specifications for structural welding from 1934 forward.

Acknowledgements

The author would like to thank the reviewers for their assistance in the development of this design guide:

John M. Barsom
Reidar Bjorhovde
Charles J. Carter
Theodore V. Galambos
Christopher M. Hewitt
Rolf Larson
Stanley D. Lindsey
Heath E. Mitchell
M. Kevin Parfitt
David T. Ricker
Raymond H.R. Tide

Their comments and suggestions have enriched this design guide. Special thanks are due to the late Frank W. Stockwell, Jr. and to Robert F. Lorenz, both formerly with AISC, whose detailed notes and drafts as referenced herein were invaluable.

Table of Contents

Author	v
Preface	v
Acknowledgements	vi
Chapter 1	
Historical Review of Specifications	1
1.1 Structural Shapes and Plates	1
1.2 Steel Pipe and Hollow Structural Sections	1
1.3 Hot-Driven Rivets	2
1.4 Structural Bolts	2
1.4.1 Carbon Steel Bolts	2
1.4.2 High Strength Steel Bolts	2
1.5 Structural Welding	3
Chapter 2	
Properties of Beam and Column Sections 1873-2000	21
2.1 Steel Sections 1971-2000	22
2.2 Steel Sections 1953 -1970	27
2.3 Steel Sections 1887-1952	35
2.4 Wrought Iron Sections 1873 – 1900	196
Chapter 3	
Evaluation of Existing Structures	215
3.1 Introduction	215
3.2 Evaluation Methods	215
3.2.1 Gravity Loads	215
3.2.2 Seismic Loads	215
3.3 Chapter N, AISC LRFD Specification	216
3.3.1 Specification Provisions	216
3.3.2 Commentary	218
Chapter 4	
Enhancement of Existing Structural Systems	223
4.1 Gravity Systems	223
4.1.1 Floors	223
4.1.2 Columns	224
4.2 Lateral Systems	224
4.2.1 Fully Restrained Moment Frames	224
4.2.2 Partially Restrained Moment Frames	225
4.2.3 Concentrically Braced Frames	225
4.2.4 Eccentric Braced Frames	225
4.3 Connections	225
4.3.1 Connection Types	225
4.3.2 Typical Methods of Reinforcement	226
4.3.3 Rehab of Seismic Moment Connections	227
4.4 Welding to Existing Members	229
4.5 Thermal Cutting of Existing Members	230
4.6 Drilling Holes in Existing Members	231
Chapter 5	
References on Rehabilitation and Retrofit	233
5.1 Reference List	233
5.2 Summaries of References	237
5.2.1 General Retrofit	237
5.2.2 Retrofit Case Studies	240
5.2.3 Seismic Retrofit	250
Appendix	
Historical Review of Specifications and Manual	259
A1. AISC Specifications – 1923 to 1999	259
A2. AISC Manual – 1927 to 1995	301
A3. Specifications for High-Strength Bolted Joints – 1951 to 2000	305
A4. Design Specifications for Structural Welding – 1934 to 1999	309
A5. AISC Code of Standard Practice – 1924 to 2000	311
Index	317

Chapter 1

HISTORICAL REVIEW OF SPECIFICATIONS

1.1 Structural Shapes and Plates

AISC and other specifications for the design of structural steel usually refer to standards published by the American Society for Testing and Materials (ASTM). Table 1.1a presents a historical summary of the pertinent ASTM standards for structural steels for buildings over the last century, with the relevant yield points and tensile strengths specified.

For further information on specific ASTM standards, refer to the appropriate *Annual Book of ASTM Standards* where available or contact ASTM, 100 Barr Harbor Drive, West Conshohocken, PA 19428-2959 (telephone 610-832-9585, website www.astm.org). Always refer to the latest published ASTM standard for current information on present structural steels.

Properties of rivet steel through 1949 are also included in Table 1.1a. For information on rivets after 1949, see Section 1.3. For information on bolts, steel pipe, and hollow structural sections, see Section 1.2. A review of structural bolts is presented in Section 1.4 and Appendix A3. A review of structural welding is presented in Section 1.5, and Appendix A4.

Table 1.1b lists the basic allowable stresses for members given in AISC allowable stress design (ASD) specifications since 1923. The allowable stress was initially 18 ksi, increasing to 20 ksi in 1936. With the advent of higher-strength steels, the allowable stress was expressed in terms of the specified minimum yield stress F_y in 1963. In 1986, the load and resistance factor design method (LRFD) was introduced. This method provided an improved design approach that included explicit consideration of limit states, load factors, resistance factors, and implicit determination of reliability. Further information on historical developments in AISC specifications, both ASD and LRFD, is given in Appendix A1. A chronological listing of publishing dates of the various versions of the AISC Manual is provided in Appendix A2.

1.2 Steel Pipe and Hollow Structural Sections (HSS)

Steel pipe and HSS were introduced to the AISC *Specification* in 1969. Included were the following:

- *A53 Pipe, Steel, Black and Hot-Dipped, Zinc-Coated, Welded and Seamless;*
- *A500 Cold-Formed Welded and Seamless Carbon Steel Structural Tubing in Rounds and Shapes;* and
- *A501 Hot-Formed Welded and Seamless Carbon Steel Structural Tubing.*

The 1978 AISC *Specification* added a fourth standard, *A618 Hot-Formed Welded and Seamless High-Strength Low-Alloy Structural Tubing*. All four standards are included in current AISC specifications. A500, A501, and A618 all include both round and shaped (usually square and rectangular) HSS.

The only standard referenced by AISC for steel pipe, A53, was first published in 1915. Only Grade B is included in the AISC specifications. A500, which is for cold-formed carbon steel product, was first published in 1964 and included two grades for round HSS and two for shaped HSS. Two more grades of each were added subsequently. A501, which is for hot-formed carbon steel product, was first published in 1964 and includes only one strength level. A618, which is for hot-formed HSLA product, was first published in 1968 and includes three strength levels.

As with other steel products, it is important to properly identify the material when investigating existing construction with steel pipe or HSS. For example, A53 steel pipe has a specified minimum yield point of 35 ksi, while round HSS can have a specified minimum yield point of 33 to 50 ksi, depending upon specification and grade. A summary of ASTM standards for steel pipe and HSS is provided in Table 1.2.

1.3 Hot-Driven Rivets

Through at least 1949, A141 specified the yield point and tensile strength of rivet steel, as indicated in Table 1.1a. For many years now, however, rivets standards have specified the material hardness instead. Hardness is generally related to tensile strength as indicated by tables in ASTM A370. All material requirements refer to the un-driven rivet.

The 1963 AISC *Specification* included three ASTM standards for rivet steel:

- A141 *Structural Rivet Steel*,
- A195 *High-Strength Rivet Steel*, and
- A406 *High-Strength Structural Alloy Rivet Steel*.

A195 and A406 were introduced for use with the higher-strength steels that were included in the AISC *Specification* at that time. A406 was discontinued in 1965 without replacement. A141 was discontinued in 1967 and replaced by A502. A195 was also discontinued in the 1960s.

The 1969 AISC *Specification* included only A502, Grade 1 or Grade 2, *Specification for Structural Rivets*. The A502 specification was originally published in 1964, combining and including previous discontinued rivet steel specifications (A141 and A195). The 1978 AISC *Specification* and subsequent editions have included A502 Grades 1, 2, and 3.

A502-93 defined three grades, with Grades 2 and 3 as the higher-hardness (higher-strength) grades. Grade 3 has enhanced atmospheric corrosion with resistance to weathering comparable to that of A588/A588M steel. Hardness values specified in A502 are listed in Table 1.3a. In 1999, A502-93 was discontinued without replacement.

Allowable stresses for hot-driven rivets as specified by AISC over the years are summarized in Table 1.3b. Design strengths according to AISC LRFD specifications are given in Table 1.3c. The latter must be used in conjunction with factored loads. Certain strength reductions for long connections may apply. Also, the combined effects of tension and shear must be considered where both are present. Other design limitations may apply. Stress calculations are always based on the nominal body area before driving, even though the area after driving will often be greater.

1.4 Structural Bolts

Two general types of bolts have been commonly used for structural steel connections:

- carbon steel bolts (A307) and
- high-strength bolts (A325, A354BC, A449, A490, and F1852).

Information on each is given in the following sections. Further details on the historical development of high-strength bolted joints is given in Appendix A2.

1.4.1 Carbon Steel Bolts

In the 1949 AISC *Specification*, the term *unfinished bolts* was used to refer to carbon steel bolts. In the 1969 and subsequent specifications, reference has been made to A307 bolts. The A307 standard was first published in 1947. These bolts have a tensile strength of 60 ksi and are not installed with pretension.

Allowable stresses from AISC specifications over the years are given in Table 1.4.1a. Design strengths according to AISC LRFD specifications are given in Table 1.4.1b. The latter must be used in conjunction with factored loads. Allowable bearing stresses are the same as for rivets, Tables 1.3b and 1.3c.

Certain strength reductions for long connections may apply. Also, the combined effects of tension and shear must be considered where both are present. Bearing and other design limitations may apply.

1.4.2 High-Strength Steel Bolts

High-strength bolts were first used in the United States after World War II to replace rivets in the maintenance of railroad bridges. The Research Council on Riveted and Bolted Structural Joints (RCRBSJ) developed the first specification for the design of connections with high-strength bolts in 1951. It identified the ASTM A325 high-strength bolt as equivalent to a hot driven ASTM 141 rivet. Numerous new editions of the specifications have been developed over the years by the RCRBSJ and its 1980 successor, the Research Council on Steel Connections (RCSC). A summary of the salient points of those specifications is given in Appendix A2. High-strength bolts were initially recognized in the 1961 AISC *Specification*.

High-strength bolts that have been used for structural connections include A325, A354 Grade BC, A449, and A490 bolts. Standards

A325, A449, and A490 were first published in 1964, and the standard for A354 in 1952. Tensile properties of these bolts are as listed in Table 1.4.2a.

Twist-off-type tension-control fastener assemblies (i.e., splined-ended bolt assemblies with nuts and washers) with properties similar to A325 bolts, were standardized in 1998 as F1852. These so-called TC bolts had been used for several years previously as A325 equivalents. Similar TC equivalents have also been used for A490 bolts. Compressible-washer-type direct tension indicators, which depend on measurement of a gap at the washer for tension control, can be furnished to F959.

It is important that appropriate nuts and washers are used with high-strength bolts. Table 1.4.2b lists acceptable types.

Bolt types for A325 are as follows: Type 1 – medium-carbon, carbon-boron, or alloy steel, quenched and tempered, Type 2 – low-carbon martensite steel, quenched and tempered, and Type 3 – weathering steel, quenched and tempered. Type 2 was withdrawn in 1991.

Bolt types for A490 are as follows: Type 1 – alloy steel, quenched and tempered, Type 2 – low-carbon martensite steel, quenched and tempered, and Type 3 – weathering steel, quenched and tempered. Type 2 was withdrawn circa 1994.

Bolt types for A449 are as follows: Type 1 – medium carbon, Type 2 – low-carbon martensite

or medium-carbon martensite steel, quenched and tempered.

Allowable stresses for high-strength bolts that have been given in RCRBSJ/RCSC specifications since first issued are given in Table 1.4.2c. These allowable stresses are usually adopted in AISC specifications as they are updated. Similarly, design strengths for LRFD specifications are given in Table 1.4.2d. The latter must be used in conjunction with factored loads, except that slip-critical connections can be checked at service loads under some conditions.

Certain strength reductions for long connections may apply. Also, the combined effects of tension and shear must be considered where both are present. Other design limitations including fatigue may apply. Hole configuration must be considered for slip-critical connections.

1.5 Structural Welding

Allowable stresses for welds that have been given by AISC manuals and specifications since the first introduction of welding in 1934 are given in Table 1.5.b. Design strengths for LRFD specifications are given in Table 1.5.c. The latter must be used in conjunction with factored loads. Further details on the historical development of specifications for welding in AISC is given in Appendix A3.

Table 1.1a
Historical Summary of ASTM Specifications for Structural Shapes and Plates

Date	Specification	Material	Yield Point[†], ksi	Tensile Strength[†], ksi
1900	A7 for Bridges	Rivet Steel Soft Steel Medium Steel	30 32 35	50/60 52/62 60/70
	A9 for Buildings	Rivet Steel Medium Steel	30 35	50/60 60/70
1901- 1904	A7 for Bridges	Rivet Steel Soft Steel Medium Steel	½ Tensile Str. ½ Tensile Str. ½ Tensile Str.	50/60 52/62 60/70
	A9 for Buildings	Rivet Steel Medium Steel	½ Tensile Str. ½ Tensile Str.	50/60 60/70
1905- 1908	A7 for Bridges	Structural Steel Rivet Steel Steel Castings	Record Value Record Value ½ Tensile Str.	60 desired 50 desired 65
	A9 for Buildings	Rivet Steel Medium Steel	½ Tensile Str. ½ Tensile Str.	50/60 60/70
1909- 1913	A7 for Bridges	Structural Steel Rivet Steel Steel Castings* *Deleted 1913.	Record Value Record Value ½ Tensile Str.	60 desired 50 desired 65
	A9 for Buildings	Structural Steel Rivet Steel	½ Tensile Str. ½ Tensile Str.	55/65 48/58
1914- 1923	A7 for Bridges	Structural Steel Rivet Steel	½ Tensile Str. ½ Tensile Str.	55/65 46/56
	A9 for Buildings	Structural Steel Rivet Steel	½ Tensile Str. ½ Tensile Str.	55/65 46/56
1924- 1931	A7 for Bridges	Structural Steel Rivet Steel	½ Tensile Str. ≥30 ½ Tensile Str. ≥25	55/65 46/56
	A9 for Buildings	Structural Steel Rivet Steel	½ Tensile Str. ≥30 ½ Tensile Str. ≥25	55/65 46/56

**Table 1.1a (Cont'd.)
Historical Summary of ASTM Specifications for Structural Steel**

Date	Specification	Material	Yield Point, ksi	Tensile Strength[†], ksi
1932	A140-32T* * Issued as a tentative revision to A7 and A9.	Plates, Shapes, & Bars	½ Tensile Str. or 33 min.	60/72
		Eyebar flats, un-annealed	½ Tensile Str. or 36 min.	67/82
	A141-32T* * Issued as a tentative revision to A7 and A9.	Rivet Steel	½ Tensile Str. or 28 min.	52/62
1933	A140-32T discontinued.	Structural Steel	½ Tensile Str. ≥30	55/65
	A7-33T (Bridges)* *Tentative revision, Oct. 30, 1933.	Plates, Shapes, & Eyebars	½ Tensile Str. ≥33	60/72
		Eyebar flats, un-annealed	½ Tensile Str. ≥36	67/82
	A9-33T (Buildings)* *Tentative revision, Oct. 30, 1933.	Structural Steel	½ Tensile Str. ≥33	60/72
	A141-32T adopted.	Rivet Steel	½ Tensile Str. ≥28	52/62
1934-1938	A7-34 for Bridges adopted.	Plates, Shapes, & Eyebars	½ Tensile Str. ≥33	60/72
		Eyebar flats, un-annealed	½ Tensile Str. ≥36	67/82
	A9-34 for Buildings adopted.	Structural Steel	½ Tensile Str. ≥33	60/72
	A141-33	Rivet Steel	½ Tensile Str. ≥28	52/62
1939-1948	A7-39* *Consolidation of A7-34 and A9-34 into one specification for bridges and buildings.	Structural Steel	½ Tensile Str. ≥33	60/72
	A141-36* *Published as tentative standards, 1932-1933. Replaced rivet steel formerly in A7 and A9.	Rivet Steel	½ Tensile Str. ≥28	52/62
	A141-39	Rivet Steel	½ Tensile Str. ≥28	52/62

**Table 1.1a (Cont'd.)
Historical Summary of ASTM Specifications for Structural Steel**

Date	Specification	Material	Yield Point, ksi	Tensile Strength[†], ksi
1949	A6-49T* * Issued as a tentative standard covering delivery requirements for A7 steel.			
	A7-49T	Structural Steel	½ Tensile Str. ≥33	60/72
	A141-49T	Rivet Steel	28	52/62
1958	A373-58T	Structural Steel	32	58-75
1961	A7-61T	Structural Steel		
		All shapes	33	60/75
		Plates/bars to 1½ in.	33	60/72
		Plates/bars over 1½ in.	33	60/75
1962	A36-62T	Structural Steel		
		All shapes	36	58/80
		Plates to 8 in.	36	58/80
		Bars to 4 in.	36	58/80
1963	A242-63T	HSLA Steel:		
		Group 1 shapes & plates/bars to ¾ in.	50	70
		Group 2 shapes & plates/bars over ¾ to 1½ in.	46	67
		Group 3 shapes & plates/bars over 1½ to 4 in.	42	63
	A440-63T	High-Strength Steel:		
		Group 1 shapes & plates/bars to ¾ in.	50	70
		Group 2 shapes & plates/bars over ¾ to 1½ in.	46	67
		Group 3 shapes & plates over 1½ to 4 in.	42	63

**Table 1.1a (Cont'd.)
Historical Summary of ASTM Specifications for Structural Steel**

Date	Specification	Material	Yield Point, ksi	Tensile Strength[†], ksi
1963 Con't.	A441-63T	HSLA Steel: Group 1 shapes & plates/bars to ¾ in.	50	70
		Group 2 shapes & plates/bars over ¾ to 1½ in.	46	67
		Group 3 shapes & plates/bars over 1½ to 4in.	42	63
		Plates/bars over 4 to 8 in.	40	60
1964	A529-64	Structural Steel: Group 1 shapes & plates/bars to ½ in.	42	60/85
	A514-64	Q&T Alloy Plate: To 2½ in. Over 2½ to 4 in.	100 90	115-135 105-135
1965	A373-58T discontinued.			
1966	A440-66	High-Strength Steel: Group 1 & 2 shapes and plates/ bars to ¾ in.	50	70
		Group 3 shapes and plates/bars over ¾ to 1½ in.	46	67
		Group 4 & 5 shapes and plates/bars over 1½ to 4 in	42	63
1967	A7-66 discontinued.			
1968	A242-68	High-Strength Steel: Group 1 & 2 shapes and plates/bars to ¾ in.	50	70
		Group 3 shapes & plates/bars over ¾ to 1½ in.	46	67
		Group 4 & 5 shapes and plates/bars over 1½ to 4in.	42	63
	A441-68	High-Strength Steel: Group 1 & 2 shapes and plates/bars to ¾ in.	50	70
		Group 3 shapes & plates/bars over ¾ to 1½ in.	46	67
		Group 4 & 5 shapes and plates/bars over 1½ to 4in. Plates/bars over 4 to 8 in.	42 40	63 60

**Table 1.1a (Cont'd.)
Historical Summary of ASTM Specifications for Structural Steel**

Date	Specification	Material	Yield Point, ksi	Tensile Strength[†], ksi
1968 Con't.	A572-68	HSLA Steel: Grade 42 - Shapes to 426 lb/ft & plates/bars to 1½ in.	42	60
		Grade 45 - Shapes to 426 lb/ft & plates/bars to 1½ in.	45	60
		Grade 50 - Shapes to 426 lb/ft & plates/bars to 1½ in.	50	65
		Grade 55 - Shapes to 426 lb/ft & plates/ bars to 1½ in.	55	70
		Grade 60 – Group 1 & 2 shapes and plates/bars to 1 in.	60	75
		Grade 65 - Group 1 shapes and plates/bars to ½ in.	65	80
		A588-68	HSLA Steel: Group 1 - 4 shapes and plates/bars to 4 in.	50
	Group 5 shapes and plates/bars over 4 to 5 in.		46	67
	Plates/bars over 5 to 8 in.		42	63
	1972	A572-72	HSLA Steel: Grade 42 - Shapes to 426 lb/ft & plates/bars to 6 in.	42
Grade 45 - Shapes to 426 lb/ft & plates/bars to 2 in.			45	60
Grade 50 - Shapes to 426 lb/ft & plates/bars to 2 in.			50	65
Grade 55 - Shapes to 426 lb/ft & plates/ bars to 1½ in.			55	70
Grade 60 – Group 1 & 2 shapes and plates/bars to 1 in.			60	75
Grade 65 - Group 1 shapes and plates/bars to ½ in.			65	80

**Table 1.1a (Cont'd.)
Historical Summary of ASTM Specifications for Structural Steel**

Date	Specification	Material	Yield Point, ksi	Tensile Strength[†], ksi
1973	A572-73	Grades 60 & 65: Maximum thickness for plates/bars now 1¼ in.		
1974	A514-74a	Q&T Alloy Plate: To 2½ in.	100	110/130
		Over 2½ to 4 in.	100	100/130
	A572-74b	HSLA Steel: Grade 42 – All shapes & plates/bars to 6 in.	42	60
		Grade 45 – All shapes & plates/bars to 2 in.	45	60
		Grade 50 – Groups 1 – 4 shapes & plates/bars to 2 in.	50	65
		Grade 55 – Shapes to 426 lb/ft & plates/ bars to 1½ in.	55	70
A588-74a	Grade 60 – Group 1 & 2 shapes and plates/bars to 1¼ in.	60	75	
	Grade 65 – Group 1 shapes and plates/bars to 1¼ in.	65	80	
1977	A514-77	Q&T Alloy Plate: To 2½ in.	100	110/130
		Over 2½ to 6 in.	100	100/130
	A572-77a Grades 45 & 55 discontinued.	HSLA Steel: Grade 42 – All shapes & plates/bars to 6 in.	42	60
		Grade 50 – Groups 1 – 4 shapes to & plates/bars to 2 in.	50	65
		Grade 60 – Group 1 & 2 shapes and plates/bars to 1¼ in.	60	75
		Grade 65 - Group 1 shapes and plates/bars to 1¼ in.	65	80

**Table 1.1a (Cont'd.)
Historical Summary of ASTM Specifications for Structural Steel**

Date	Specification	Material	Yield Point, ksi	Tensile Strength[†], ksi
1978	A440-77 discontinued. A572-78	Grade 50: Now covers all shape grades.		
1982	A572-82	Grade 50: Now covers all shape grades & plates/bars to 4 in.		
1985	A852/A852M-85	Q&T Low Alloy: To 4 in.	70	90/110
1989	A441 discontinued.	High-Strength Steel		
1992	A529/A529M-92 A572-92a	Structural Steel: Grade 42 - Group 1 shapes & plates/bars to ½ in. Grade 50 - Group 1 & 2 shapes, plates to 1 in. x 12 in., and bars to 1½ in. HSLA Steel: Grade 42 – All shapes & plates/bars to 6 in. Grade 50 – All shapes to & plates/bars to 4 in. Grade 60 – Group 1, 2 & 3 shapes and plates/bars to 1¼ in. Grade 65 - Group 1, 2 & 3 shapes and plates/bars to 1¼ in.	42 50 42 50 60 65	60/85 70 to100 60 65 75 80
1993	A913/A913M-93	QST HSLA Steel: Grade 60 – All shapes. Grade 65 – All shapes. Grade 70 – All shapes.	60 65 70	75 80 90
1995	A913/A913M-95	QST HSLA Steel: Grade 50 – All shapes. Grade 60 – All shapes. Grade 65 – All shapes. Grade 70 – All shapes.	50 60 65 70	65 75 80 90
1996	A529/A529M-96	Structural Steel: Grade 50 - Group 1 & 2 shapes, plates to 1 in. x 12 in., and bars to 2½ in. Grade 55 - Group 1 & 2 shapes, plates to 1 in. x 12 in., and bars to 1½ in.	50 55	70/100 70 to100

**Table 1.1a (Cont'd.)
Historical Summary of ASTM Specifications for Structural Steel**

Date	Specification	Material	Yield Point, ksi	Tensile Strength[†], ksi
1998	A992/A992M-98* *Introduced as new specification for structural shapes for buildings. Includes limits on yield-tensile ratio and carbon equivalent.	Structural Steel: All W shapes.	50 min./65 max.* *Yield-tensile ratio = 0.85 max.	65
2000	A572/A572M-00	HSLA Steel: Grade 42 – All shapes & plates/bars to 6 in. Grade 50 – All shapes to & plates/bars to 4 in. Grade 55 – All shapes & plates/ bars to 2 in. Grade 60 – Group 1, 2 & 3 shapes and plates/bars to 1¼ in. Grade 65 - Group 1, 2 & 3 shapes and plates/bars to 1¼ in.	42 50 55 60 65	60 65 70 75 80
Current (2001)	A36/A36M-00a A242/A242M-00a A514/A514M-00a A529/A529M-00 A572/A572M-00 A588/A588M-00 A852/A852M-00a A913/A913M-00a A992/A992M-98	Structural Steel HSLA Steel Q&T Alloy Steel Structural Steel HSLA Steel HSLA Steel Q&T Low Alloy Steel QST HSLA Steel Structural Steel	Same as 1962 Same as 1968 Same as 1977 Same as 1996 See 2000 Same as 1974 Same as 1985 Same as 1995 See 1998	Same as 1962 Same as 1968 Same as 1977 Same as 1996 See 2000 Same as 1974 Same as 1985 Same as 1997 See 1998

[†] Properties are specified minimum except minimum/maximum where two values are listed. “Record Value” indicates that the value is recorded but no value is specified. “Desired” indicates a value that is aimed for, but no value is specified.

Table 1.1b
Historical Basic Allowable Stresses (ksi) in AISC Specifications*

AISC Specification	Tension	Bending	Bending in Compact Shapes
1923	18	18	-
1936	20	20	-
1963-1989	$0.60 F_y$	$0.60 F_y$	$0.66 F_y$
* F_y = specified minimum yield stress, ksi			

Table 1.2
Historical Summary of ASTM Specifications for Steel Pipe and HSS

Date	Specification	Material	Yield Point, ksi	Tensile Strength[†], ksi
1963	A53-63T First published in 1915.	Steel Pipe, Welded and Seamless: Grade B	35	60
1964	A500-64 A501-64	Cold-Formed Welded and Seamless Carbon Steel Structural Tubing in Rounds and Shapes: Round Grade A Round Grade B Shaped Grade A Shaped Grade B	33 42 39 46	45 58 45 58
		Hot-Formed Welded and Seamless Carbon Steel Structural Tubing	36	58/80
1968	A618-68	Hot-Formed Welded and Seamless High-Strength Low-Alloy Structural Tubing: Grade I Grade II Grade III	50 50 50	70 70 65
1974	A500-74a Grade C added.	Round Grade C	46	62
		Shaped Grade C	50	62
1990	A500-90a Grade D added.	Round Grade D	36	58
		Shaped Grade D	36	58
1981	A618-81 Grade designations changed.	Grades Ia, Ib, & II with walls to ¾ in.	50	70
		Grades Ia, Ib, & II with walls ¾ - 1½ in.	46 50	67 65
		Grade III		
To Date	A53/A53M-99b	Steel Pipe	Same as 1963	Same as 1963
	A500-99	Cold-Formed Tubing	Same as 1990	Same as 1990
	A501-99	Hot-Formed Carbon Steel Tubing	Same as 1964	Same as 1964*
	A618-99	Hot-Formed HSLA Tubing	Same as 1981	Same as 1981

[†] Properties are specified minimum except minimum/maximum where two values are listed.

*For A501, the 80 ksi upper limit was discontinued circa 1968 – 1988.

Table 1.3a
Hardness Requirements for ASTM A502 Steel Structural Rivets*

Hardness Measurement Type	Grade 1 – Min./Max.	Grade 2 – Min./Max.	Grade 3 – Min./Max.
Rockwell B	55/72	76/85	76/93
Brinell, 500-kgf (4900-N), 10-mm ball	103/126	137/163	137/197
* As specified in A502-93.			

Table 1.3b
Historical AISC Allowable Stresses (ksi) for Rivets – ASD*

AISC Spec. Year	Type of Rivet	Tension	Shear	Bearing
1928	A9	13.5	13.5	
1936	A141	15.0	15.0	32.0/40.0**
1949	A141	20.0	15.0	32.0/40.0**
1963	A141	20.0	15.0	1.35 F_y
	A195 & A406	27.0	20.0	1.35 F_y
1969	A502 Grade 1	20.0	15.0	1.35 F_y
	A502 Grade 2	27.0	20.0	1.35 F_y
1978	A502 Grade 1	23.0	17.5	1.50 F_u
	A502 Grade 2 or 3	29.0	22.0	1.50 F_u
1989	A502 Grade 1	23.0	17.5	1.20 F_u
	A502 Grade 2 or 3	29.0	22.0	1.20 F_u
* The allowable stress is based on the nominal body area before driving.				
** Lower value for single shear, larger value for double shear.				

Table 1.3c
Historical AISC Design Strength (ksi) for Rivets – LRFD*

AISC Spec. Year	Type of Rivet	Tension, ϕF_t	Shear, ϕF_v	Bearing, ϕF_n
1986	A502 Grade 1	33.8	23.4	1.80 F_u
	A502 Grade 2 or 3	45.0	31.2	1.80 F_u
1993	A502 Grade 1	33.8	18.8	1.80 F_u
	A502 Grade 2 or 3	45.0	24.8	1.80 F_u
1999	A502 Grade 1	33.8	18.8	1.80 F_u
	A502 Grade 2 or 3	45.0	24.8	1.80 F_u
* Stress on nominal body area before driving.				

Table 1.4.1a
Historical AISC Allowable Stresses (ksi) for
Unfinished Carbon Steel Bolts or A307 Bolts - ASD

AISC Spec. Year	Tension	Shear	Bearing
1936	Not specified.	10*	20.0/25.0 [†]
1941	12	10*	20.0/25.0 [†]
1946	20	10*	20.0/25.0 [†]
1949	20**	10*	20.0/25.0 [†]
1963	14*	10*	1.35 F_y
1969	20***	10*	1.35 F_y
1978	20*	10*	1.50 F_u
1989	20*	10*	1.20 F_u

* Stress on nominal body area.
** Stress on nominal area at root of thread. Values are tabulated in AISC Manual, Fifth Ed., and as “section at minor diameter” in current ANSI B1.1.
*** Stress on defined tensile stress area (in.²), $A_s = 0.7854[D - (0.9743/n)]^2$, where D (in.) is nominal diameter and n is number of threads per in.
[†] Lower value for single shear, larger value for double shear.

Table 1.4.1b
Historical AISC Design Strength (ksi) for A307 Bolts – LRFD*

AISC Spec. Year	Tension, ϕF_t	Shear, ϕF_v	Bearing, ϕF_n
1986	0.75 x 45 = 34	0.60 x 27 = 16	1.80 F_u
1993	0.75 x 45 = 34	0.75 x 24 = 18	1.80 F_u
1999	0.75 x 45 = 34	0.75 x 24 = 18	1.80 F_u

* Stress on nominal body area.

**Table 1.4.2a
Current Tensile Properties of High-Strength Bolts***

ASTM Designation	Description**	Diameter, in.	Specified Min. Proof Load Divided by Stress Area, ksi	Specified Tensile Load Divided by Stress Area, ksi
A325	Heat treated structural bolts, Type 1, 2, or 3	½ to 1, incl. 1 1/8 to 1 ½, incl.	85 74	120 105
A490	Heat treated structural bolts, Type 1, 2, or 3	½ to 1 ½, incl.	120	150 - 170
A354 Grade BC	Quenched and tempered alloy steel bolts	¼ to 2 ½ incl., 2 ½ to 4 incl.	105 95	125 115
A449	Quenched and tempered steel bolts and studs: Type 1 (¼ to 3) Type 2 (¼ to 1)	¼ to 1, incl. 1 1/8 to 1 ½, incl. 1 ¾ to 3, incl.	85 74 55	92 81 58

* Based on current ASTM specifications. Changes over past years believed to be relatively minor. In column 4, an alternative proof load definition gives higher values.

** Type 2 bolts were withdrawn from ASTM standards A325 (1991), and A490 (circa 1994).

**Table 1.4.2b
Current Acceptable Nuts and Washers for High-Strength Bolts***

ASTM Designation	Bolt Type	Bolt Finish	A563 Nut, Grade, and Finish	F436 Washer Type and Finish
A325	1	Plain (uncoated)	C, C3, D, DH and DH3; plain	1; plain
		Galvanized	DH; galvanized and lubricated	1; galvanized
	3	Plain	C3 and DH3; plain	3; plain
A1852	1	Plain (uncoated)	C, C3, D, DH and DH3; plain	1; plain
		Mechanically galvanized	DH; mech. galvanized and lubricated	1; mech. galvanized
	3	Plain	C3 and DH3; plain	3; plain
A490	1	Plain	DH and DH3; plain	1; plain
	3	Plain	DH3; plain	3; plain

* Based on current RCSC specifications, which should be referred to for complete details. The substitution of A194 grade 2H nuts in place of A563 grade DH nuts is permitted. F959 direct tension indicator washers are permitted with A325 and A490 bolts.

Table 1.4.2c
Historical RCSC Allowable Stresses (ksi) for High-Strength Bolts – ASD*

RCSC Date	Bolt Type	Tension	Shear, Slip-Critical Type	Shear, Bearing Type, Threads Incl.	Shear, Bearing Type, Threads Excl.	Bearing
1951	A325	20	15	15	15	32/40 [†]
1960	A325	40	15	15	22	46
1962	A325	40	15	15	22	45
	A354BC**	50	20	20	24	45
1964	A325	40	15	15	22	1.35 F_y
	A490	60	22.5	22.5	32	1.35 F_y
1966	A325	40	15	15	22	1.35 F_y
	A490	54	20	22.5	32	1.35 F_y
1976	A325	44	17.5***	21	30	1.50 F_u
	A490	54	22***	28	40	1.50 F_u
1985	A325					1.20 F_u where deformation is a consideration; otherwise, 1.50 F_u
	Cl. A surf.	44	17	21	30	
	Cl. B surf.	44	28	21	30	
	Cl. C surf.	44	22	21	30	
	A490					
	Cl. A surf.	54	21	28	40	
Cl. B surf.	54	34	28	40		
Cl. C surf.	54	27	28	40		
1994	Unchanged.					
2000	A325	44	Varies with bolt pretension and surface condition.	21	30	1.20 F_u where deformation is a consideration; otherwise, 1.50 F_u
	A490	54		30	40	

* Stress on nominal body area.

** Stresses per AISC Specification; not included in RCSC.

*** Values vary for surface conditions.

† Lower value for single shear, larger value for double shear.

Table 1.4.2d
Historical RCSC Design Strengths (ksi) for High-Strength Bolts – LRFD*

RCSC Date	Bolt Type	Tension	Shear, Slip-Critical Type**	Shear, Bearing Type, Threads Incl.	Shear, Bearing Type, Threads Excl.	Bearing
1988	A325	0.75x90=		0.75x48=	0.75x60=	0.75x2.4F _u =
	Cl. A surf.	67.5	17	36	45	1.80 F _u
	Cl. B surf.	67.5	28	36	45	1.80 F _u
	Cl. C surf.	67.5	22	36	45	1.80 F _u
	A490	0.75x113=		0.75x60=	0.75x75=	0.75x2.4F _u =
	Cl. A surf.	85	21	45	56	1.80 F _u
	Cl. B surf.	85	34	45	56	1.80 F _u
	Cl. C surf.	85	27	45	56	1.80 F _u
	1994	A325	0.75x90=67.5	Varies with bolt pretension and surface condition.	0.75x48=36	0.75x60=45
A490		0.75x113=85	0.75x60=45		0.75x75=56	
2000	Unchanged.					

* Stress on nominal body area.
** Based on $\phi = 1.0$, slip probability = 0.81, and slip coefficient = 0.33, Class A surface.

Table 1.5a
Historical AISC Allowable Stresses (ksi) for Welds - ASD

Year	Source	Steels and Welding Materials	Fillet Weld Shear	Tension	Compression
1934	AISC Manual	A7/A9 steel	11.3	13	15
1939	AISC Manual	A7/A9 steel	11.3	13	18
1946	AISC Spec.	A7/A9 steel: 60xx electrodes.	13.6	20	20
1961, 1963	AISC Spec.	All steels: 60xx electrodes or subarc Grade SAW-1. A7 and A373 steels: 70xx or subarc Grade SAW-2. A36, A242, and A441 steels: 70xx or subarc Grade SAW-2.	13.6 13.6 15.8	Same as member, all cases.	Same as member, all cases.
1969	AISC Spec.	All steels and weld processes.**	$0.30F_{uw}$	“	“
1989	AISC Spec.	No significant changes.	$0.30F_{uw}$	“	“

* 13.0 for shear in butt welds.
 ** Electrodes and matching base metals are defined. Allowable shear stress is 0.30 times nominal tensile strength of weld metal, $0.30F_{uw}$. Supplement 3, 1974, permitted weld metal with a strength level equal to or less than matching base metal, except for tension members.

Table 1.5b
Historical AISC Design Strengths (ϕF_w or ϕF_{BM} , ksi) for Welds - LRFD

Year	Source	Steels and Welding Materials	Fillet Weld Shear	CJP Groove Weld in Tension	CJP Groove Weld in Compression
1986	AISC Spec.	All	$0.75 \times 0.60 F_{EXX}$ $= 0.45 F_{EXX}$	$0.90 F_y$	$0.90 F_y$
1993	AISC Spec.	“	“	“	“
1999	AISC Spec.	“	“	“	“

Symbols:
 F_w = Nominal strength of weld electrode material, ksi
 F_{BM} = Nominal strength of base metal, ksi
 F_{EXX} = Classification number weld metal (minimum specified strength), ksi
 F_y = Specified minimum yield stress of steel being welded, ksi

Chapter 2

PROPERTIES OF **DISCONTINUED** BEAMS AND COLUMNS 1873-2000

Rev.
5/1/02

For Steel Sections 1971-2000 (Section 2.1) and Steel Sections 1953-1970 (Section 2.2), the following properties were taken from old AISC Manuals, or calculated where missing.

For Steel Sections 1887-1952 (Section 2.3) and Wrought Iron Sections 1873-1900 (Section 2.4), the properties were taken from *Iron and Steel Beams -1873 to 1952*, or calculated where missing. Thus, the format differs somewhat from that for the sections taken from the AISC Manuals. The depth, web thickness, flange width, and flange thickness are shown only as decimal values. Dimensions T , k , and k_f are shown as decimals rather than fractions.

For Steel Sections 1887-1952 (Section 2.3), the "Designation" for 14 sections are shown as "—". These were sections have no known designation. For Wrought Iron Sections 1873-1900 (Section 2.4), the "Designation" is simply shown as a sequential number from 1 to 295 as they have and have no known designation.

2.1 Steel Sections 1971-2000

The following information can be found in Tables 2.1.1 through 2.1.3:

Table 2.1.1 - Dimensions and Primary Properties
Table 2.1.2 - Torsion Properties
Table 2.1.3 - Producers

2.2 Steel Sections 1953-1970

The following information can be found in Tables 2.2.1 through 2.2.3:

Table 2.2.1 — Dimensions and Primary Properties
Table 2.2.2 — Torsion Properties
Table 2.2.3 - Producers

These tables list WF using the W-designation.

2.3 Steel Sections 1887-1952

The following information can be found in Tables 2.2.1 through 2.2.3:

Table 2.3.1 — Dimensions and Primary Properties
Table 2.3.2 - Torsion Properties
Table 2.3.3 - Producers Key
2.3.3a American Standard Beams
2.3.3b Beams (Steel) WF Regular and Special
2.3.3c WF Shapes (Steel) Light Columns and Stanchions
2.3.3d Light Beams, Joists and Junior Beams (Steel)
2.3.3e Columns (Steel)

2.4 Wrought Iron Sections 1873-1900

The following information can be found in Tables 2.2.1 through 2.2.3:

Table 2.4.1 — Dimensions and Primary Properties
Table 2.4.2 - Torsion Properties
Table 2.4.3 - Producers Key

Rev.
5/1/02

Table 2.1.1 Dimensions and Primary Properties -- Steel Sections 1971-2000

Designation	Wt. per ft lb	Area A in. ²	Depth		Web Thickness			Flange Width		Flange Thickness		Distance		
			d	d	t _w	t _w	t _w /2	b _f	b _f	t _f	t _f	T	k	k ₁
			in.	in.	in.	in.	in.	in.	in.	in.	in.	in.	in.	in.
W44x285	285	83.8	44.02	44	1.024	1	1/2	11.811	11 3/4	1.772	1 3/4	38 5/8	2 11/16	1 3/8
W44x248	248	72.8	43.62	43 5/8	0.865	7/8	7/16	11.811	11 3/4	1.575	1 9/16	48 5/8	2 1/2	1 5/16
W44x224	224	65.8	43.31	43 1/4	0.787	13/16	7/16	11.811	11 3/4	1.416	1 7/16	48 5/8	2 5/16	1 5/16
W44x198	198	58.0	42.91	42 7/8	0.709	11/16	3/8	11.811	11 3/4	1.220	1 1/4	48 5/8	2 1/8	1 1/4
W40x655	655	192	43.62	43 5/8	1.970	2	1	16.870	16 7/8	3.540	3 9/16	33 3/4	4 15/16	2 1/4
W40x531	531	156	42.34	42 3/8	1.610	1 5/8	13/16	16.510	16 1/2	2.910	2 15/16	33 3/4	4 5/16	2
W40x480	480	140	41.81	41 3/4	1.460	1 7/16	3/4	16.360	16 3/8	2.640	2 5/8	33 3/4	4	2
W40x466	466	137	42.44	42 7/16	1.670	1 11/16	13/16	12.640	12 5/8	2.950	2 15/16	34 3/16	4 1/8	2
W40x436	436	128	41.34	41 3/8	1.340	1 5/16	11/16	16.240	16 1/4	2.400	2 3/8	33 3/4	3 13/16	1 15/16
W40x328	328	96.4	40.00	40	0.910	15/16	1/2	17.910	17 7/8	1.730	1 3/4	33 3/4	3 1/8	1 11/16
W40x321	321	94.1	40.08	40 1/16	1.000	1	1/2	15.910	15 7/8	1.770	1 3/4	34 3/16	2 15/16	1 11/16
W40x298	298	87.6	38.69	38 3/4	0.830	13/16	7/16	17.830	17 7/8	1.575	1 9/16	33 3/4	3	1 5/8
W40x268	268	78.8	39.37	39 3/8	0.750	3/4	3/8	17.750	17 3/4	1.415	1 7/16	33 3/4	2 13/16	1 9/16
W40x244	244	71.7	39.06	39	0.710	11/16	3/8	17.710	17 3/4	1.260	1 1/4	33 3/4	2 5/8	1 9/16
W40x221	221	64.8	38.67	38 5/8	0.710	11/16	3/8	17.710	17 3/4	1.065	1 1/16	33 3/4	2 7/16	1 9/16
W40x192	192	56.5	38.20	38 1/4	0.710	11/16	3/8	17.710	17 3/4	0.830	13/16	33 3/4	2 1/4	1 9/16
W40x174	174	51.1	38.20	38 1/4	0.650	5/8	5/16	15.750	15 3/4	0.830	13/16	34 3/16	2	1 1/2
W36x848	848	249	42.45	42 1/2	2.520	2 1/2	1 1/4	18.130	18 1/8	4.530	4 1/2	31 1/8	5 11/16	2 1/4
W36x720	720	211	41.19	41 1/4	2.165	2 3/16	1 1/8	17.775	17 3/4	3.900	3 7/8	31 1/8	5 1/16	2 1/16
W36x588	588	172	39.84	39 7/8	1.790	1 13/16	1	17.400	17 3/8	3.230	3 1/4	31 1/8	4 3/8	1 7/8
W36x485	485	142	38.74	38 3/4	1.500	1 1/2	3/4	17.105	17 1/8	2.680	2 11/16	31 1/8	3 13/16	1 3/4
W33x619	619	181	38.47	38 1/2	1.970	2	1	16.910	16 7/8	3.540	3 9/16	29 3/4	4 3/8	1 3/4
W33x567	567	166	37.91	37 7/8	1.810	1 13/16	1	16.750	16 3/4	3.270	3 1/4	29 3/4	4 1/16	1 11/16
W33x515	515	151	37.36	37 3/8	1.650	1 5/8	13/16	16.590	16 5/8	2.990	3	29 3/4	3 13/16	1 5/8
W33x468	468	137	36.81	36 3/4	1.520	1 1/2	3/4	16.455	16 1/2	2.720	2 3/4	29 3/4	3 1/2	1 9/16
W33x424	424	124	36.34	36 3/8	1.380	1 3/8	11/16	16.315	16 3/8	2.480	2 1/2	29 3/4	3 5/16	1 7/16
W33x387	387	113	35.95	36	1.260	1 1/4	5/8	16.200	16 1/4	2.280	2 1/4	29 3/4	3 1/8	1 3/8
W30x581	581	170	35.39	35 3/8	1.970	2	1	16.200	16 1/4	3.540	3 9/16	26 3/4	4 5/16	1 11/16
W30x526	526	156	34.76	34 3/4	1.790	1 13/16	1	16.020	16	3.230	3 1/4	26 3/4	4	1 5/8
W30x433	433	127	33.66	33 5/8	1.500	1 1/2	3/4	15.725	15 3/4	2.680	2 11/16	26 3/4	3 7/16	1 1/2
W30x357	357	104	32.80	32 3/4	1.240	1 1/4	5/8	15.470	15 1/2	2.240	2 1/4	26 3/4	3	1 3/8
W30x477	477	140	34.21	34 1/4	1.630	1 5/8	13/16	15.865	15 7/8	2.950	3	26 3/4	3 3/4	1 9/16
W27x494	494	145	31.97	32	1.810	1 13/16	1	15.095	15 1/8	3.270	3 1/4	24	4	1 9/16
W27x448	448	131	31.42	31 3/8	1.650	1 5/8	13/16	14.940	15	2.990	3	24	3 11/16	1 1/2
W27x407	407	119	30.87	30 7/8	1.520	1 1/2	3/4	14.800	14 3/4	2.720	2 3/4	24	3 7/16	1 7/16
W24x492	492	144	29.65	29 5/8	1.970	2	1	14.115	14 1/8	3.540	3 9/16	21	4 5/16	1 9/16
W24x450	250	132	29.09	29 1/8	1.810	1 13/16	1	13.955	14	3.270	3 1/4	21	4 1/16	1 1/2
W24x408	408	119	28.54	28 1/2	1.650	1 5/8	13/16	13.800	13 3/4	2.990	3	21	3 3/4	1 3/8
W21x402	402	118	26.02	26	1.730	1 3/4	7/8	13.405	13 3/8	3.130	3 1/8	18 1/4	3 7/8	1 7/16
W21x364	364	107	25.47	25 1/2	1.590	1 9/16	13/16	13.265	13 1/4	2.850	2 7/8	18 1/4	3 5/8	1 3/8
W21x333	333	97.9	25.00	25	1.460	1 7/16	3/4	13.130	13 1/8	2.620	2 5/8	18 1/4	3 3/8	1 5/16
W21x300	300	88.2	24.53	24 1/2	1.320	1 5/16	11/16	12.990	13	2.380	2 3/8	18 1/4	3 1/8	1 1/4
W21x275	275	80.8	24.13	24 1/8	1.220	1 1/4	5/8	12.890	12 7/8	2.190	2 3/16	18 1/4	3	1 3/16
W21x248	248	72.8	23.74	23 3/4	1.100	1 1/8	9/16	12.775	12 3/4	1.990	2	18 1/4	2 3/4	1 1/8
W21x223	223	65.4	23.35	23 3/8	1.000	1	1/2	12.675	12 5/8	1.790	1 13/16	18 1/4	2 9/16	1 1/16
W18x311	311	91.5	22.32	22 3/8	1.520	1 1/2	3/4	12.005	12	2.740	2 3/4	15 1/2	3 7/16	1 3/16
W18x283	283	83.2	21.85	21 7/8	1.400	1 3/8	11/16	11.890	11 7/8	2.500	2 1/2	15 1/2	3 3/16	1 3/16
W18x258	258	75.9	21.46	21 1/2	1.280	1 1/4	5/8	11.770	11 3/4	2.300	2 5/16	15 1/2	3	1 1/8
W18x234	234	68.8	21.06	21	1.160	1 3/16	5/8	11.650	11 5/8	2.110	2 1/8	15 1/2	2 3/4	1
W18x211	211	62.1	20.67	20 5/8	1.060	1 1/16	9/16	11.555	11 1/2	1.910	1 15/16	15 1/2	2 9/16	1
W18x192	192	56.4	20.35	20 3/8	0.960	1	1/2	11.455	11 1/2	1.750	1 3/4	15 1/2	2 7/16	15/16
M14x18	18	5.10	14.00	14	0.215	3/16	1/8	4.000	4	0.270	1/4	12 3/4	5/8	-
M6x20	20	5.89	6.00	6	0.250	1/4	1/8	5.938	6	0.379	3/8	4 1/4	7/8	-
M4x13	13	3.81	4.00	4	0.254	1/4	1/8	3.940	4	0.371	3/8	2 3/8	13/16	-
S7x20	20	5.88	7.00	7	0.450	7/16	1/4	3.860	3 7/8	0.392	3/8	5 1/8	15/16	-
S7x15.3	15.3	4.50	7.00	7	0.252	1/4	1/8	3.662	3 5/8	0.392	3/8	5 1/8	15/16	-
S5x14.75	14.75	4.34	5.00	5	0.494	1/2	1/4	3.284	3 1/4	0.326	5/16	3 3/8	13/16	-
HP13x100	100	29.4	13.15	13 1/8	0.765	3/4	3/8	13.205	13 1/4	0.765	3/4	10 1/4	1 7/16	1
HP13x87	87	25.5	12.95	13	0.665	11/16	3/8	13.105	13 1/8	0.665	11/16	10 1/4	1 3/8	15/16
HP13x73	83	21.6	12.75	12 3/4	0.565	9/16	5/16	13.005	13	0.565	9/16	10 1/4	1 1/4	15/16
HP13x60	60	17.5	12.54	12 1/2	0.460	7/16	1/4	12.900	12 7/8	0.460	7/16	10 1/4	1 1/8	7/8

Rev.
5/1/02

Table 2.1.1 Dimensions and Primary Properties -- Steel Sections 1971-2000

Compact Section Criteria			Elastic Properties									Plastic Modulus	
$b_f/2t_f$	h/t_w	F_y^{min} ksi	X_1 ksi	$X_2 \times 10^6$ (1/ksi) ²	Axis x-x			Axis y-y			Z_x in. ³	Z_y in. ³	
					I_x in. ⁴	S_x in. ³	r_x in.	I_y in. ⁴	S_y in. ³	r_y in.			
3.3	37.7	36	2535	4966	24600	1120	17.1	490	83.0	2.42	1310	135	
3.7	44.6	26	2217	8210	21400	983	17.2	435	74.0	2.44	1150	118	
4.2	49.2	22	2001	12318	19200	889	17.1	391	66.0	2.44	1030	105	
4.8	54.5	18	1762	20652	16700	776	16.9	336	57.0	2.41	902	90.0	
2.4	17.1	-	5229	240	56500	2590	17.2	2860	339	3.86	3060	541	
2.8	20.9	-	4340	496	44300	2090	16.9	2200	266	3.75	2450	422	
3.1	23.2	-	3923	723	39500	1890	16.8	1940	237	3.72	2180	374	
2.1	20.5	-	4560	473	36300	1710	16.3	1010	160	2.72	2050	262	
3.4	25.2	-	3613	1017	35400	1710	16.6	1720	212	3.67	1980	334	
5.2	37.1	34	2527	3803	26800	1340	16.7	1660	185	4.15	1510	286	
4.5	34.2	-	2690	3240	25100	1250	16.3	1190	150	3.56	1420	234	
5.7	39.4	29	2305	5427	24200	1220	16.6	1490	167	4.12	1370	257	
6.3	45.0	24	2090	8071	21500	1090	16.5	1320	149	4.09	1220	229	
7.0	47.6	22	1901	11883	19200	983	16.4	1170	132	4.04	1100	203	
8.3	47.6	22	1729	18450	16600	858	16.0	988	112	3.90	967	172	
10.7	47.5	23	1573	29641	13500	708	15.5	770	87.0	3.69	807	135	
9.5	52.6	23	1500	36000	12200	639	15.5	541	68.8	3.26	715	107	
2.0	12.5	-	7100	71.0	67400	3170	16.4	4550	501	4.27	3830	799	
2.3	14.3	-	6130	123	55300	2690	16.2	3680	414	4.18	3190	656	
3.7	17.4	-	5126	246	43500	2180	15.9	2850	328	4.07	2550	517	
3.2	20.7	-	4298	488	34700	1790	15.6	2250	263	3.98	2070	412	
2.4	15.1	-	5910	142	41800	2170	15.2	2870	340	3.98	2560	537	
2.6	16.5	-	5462	191	37700	1990	15.1	2580	308	3.94	2330	485	
2.8	18.0	-	4997	268	33700	1810	14.9	2290	276	3.89	2110	433	
3	19.6	-	4600	374	30100	1630	14.8	2030	247	3.85	1890	387	
3.3	21.5	-	4185	535	26900	1480	14.7	1800	221	3.81	1700	345	
3.6	23.6	-	3848	740	24300	1350	14.7	1620	200	3.79	1550	312	
2.3	13.6	-	6469	97.2	33000	1870	13.9	2530	312	3.86	2210	492	
2.5	14.9	-	10999	135	29300	1680	13.8	2230	278	3.80	1990	438	
2.9	17.9	-	4969	271	23200	1380	13.5	1750	222	3.71	1610	348	
3.5	21.6	-	4146	536	18600	1140	13.4	1390	179	3.65	1300	279	
2.7	16.6	-	5420	193	26100	1530	13.7	1970	249	3.75	1790	390	
2.3	13.2	-	6620	88.3	22900	1440	12.6	1890	250	3.61	1710	394	
2.5	14.7	-	6070	123	20400	1300	12.5	1670	224	3.57	1530	351	
2.7	15.8	-	5599	170	18100	1170	12.3	1480	200	3.52	1380	313	
2.0	10.9	-	7950	43.0	19100	1290	11.5	1670	237	3.41	1550	375	
2.1	11.6	-	7428	56.8	17100	1170	11.4	1490	214	3.36	1410	337	
2.3	13.1	-	6780	79.0	15100	1060	11.3	1320	191	3.33	1250	300	
2.1	10.6	-	7999	41.2	12200	937	10.2	1270	189	3.27	1130	296	
2.3	11.5	-	7343	57.2	10800	846	10.0	1120	168	3.23	1010	263	
2.5	12.5	-	6795	77.7	9610	769	9.91	994	151	3.19	915	237	
2.7	13.8	-	6195	111	8480	692	9.81	873	134	3.15	816	210	
2.9	14.9	-	5723	150	7620	632	9.71	785	122	3.12	741	189	
3.2	16.6	-	5206	215	6760	569	9.63	694	109	3.09	663	169	
3.5	18.2	-	4704	319	5950	510	9.54	609	96.1	3.05	589	149	
2.2	10.6	-	8160	38.0	6960	624	8.72	795	132	2.95	753	207	
2.4	11.5	-	7520	52.0	6160	564	8.61	704	118	2.91	676	185	
2.6	12.5	-	6920	71.0	5510	514	8.53	628	107	2.88	611	166	
2.8	13.8	-	6360	97.0	4900	466	8.44	558	95.8	2.85	549	149	
3.0	15.1	-	5900	140	4330	419	8.35	493	85.3	2.82	490	132	
3.3	16.7	-	5320	194	3870	380	8.28	440	76.8	2.79	442	119	
7.4	59.3	-	1421	110218	148	21.1	5.38	2.64	1.32	0.719	24.9	2.20	
7.8	18.5	-	4090	15600	39.0	13.0	2.57	11.6	3.90	1.40	14.5	6.25	
5.3	10.4	-	6500	79.9	10.5	5.24	1.66	3.36	1.71	0.939	6.05	2.74	
4.9	11.4	-	5382	486	42.4	12.1	2.69	3.17	1.64	0.734	14.50	2.96	
4.7	20.3	-	3962	1221	36.7	10.5	2.86	2.64	1.44	0.766	12.10	2.44	
5.0	6.8	-	7747	170	15.2	6.09	1.87	1.67	1.01	0.620	7.42	1.88	
8.6	13.4	-	4020	53079	886	135	5.49	294	44.5	3.16	153	68.6	
9.9	15.3	-	3507	77497	755	117	5.45	250	38.1	3.13	131	58.5	
11.5	18.1	-	3001	119583	630	98.8	5.40	207	31.9	3.10	110	48.8	
14.0	22.4	-	2459	208663	503	80.3	5.36	165	25.5	3.07	89.0	39.0	

Table 2.1.2 Torsion Properties -- Steel Sections 1971-2000

Designation	Torsional Constant	Warping Constant	$(EC_w/GJ)^{1/2} =$	Normalized Warping Constant	Warping Statical Moment	Statical Moment	Statical Moment
	J	C_w	a	W_{no}	S_w	Q_f	Q_w
	in. ⁴	in. ⁶	in.	in. ²	in. ⁴	in. ³	in. ³
W44x285	60.0	219000	97.2	125	653	204	657
W44x248	40.7	192000	111	124	577	184	574
W44x224	30.0	172000	122	124	517	166	517
W44x198	20.1	146000	137	123	443	144	450
W40x655	596	1140000	70.4	169	2520	534	1530
W40x531	329	848000	81.7	163	1950	433	1230
W40x480	245	739000	88.4	160	1730	391	1090
W40x466	277	393000	60.6	125	1160	322	1030
W40x436	186	649000	95.1	158	1540	354	992
W40x328	74.2	607000	145	171	1330	287	755
W40x321	79.4	446000	152	152	1100	264	730
W40x298	56.3	540000	158	170	1190	261	684
W40x268	41.1	475000	173	168	1060	234	612
W40x244	30.4	417000	188	167	934	208	550
W40x221	21.2	349000	206	166	785	176	483
W40x192	13.7	268000	225	165	608	137	404
W40x174	11.2	189000	209	147	481	119	364
W36x848	1270	1620000	57.5	172	3530	674	1910
W36x720	804	1270000	64.0	166	2870	571	1590
W36x588	453	950000	73.7	159	2240	465	1280
W36x485	260	727000	85.2	154	1770	380	1040
W33x619	567	870000	63.0	148	2210	463	1280
W33x567	444	768000	66.9	145	1990	425	1170
W33x515	338	672000	71.8	143	1770	385	1060
W33x468	256	587000	77.1	140	1570	348	947
W33x424	193	514000	83.1	138	1400	315	852
W33x387	149	458000	89.2	136	1260	288	773
W30x581	537	636000	55.4	129	1850	402	1110
W30x526	405	550000	59.3	126	1630	364	993
W30x433	231	417000	68.3	122	1280	297	805
W30x357	134	323000	79.1	118	1020	245	650
W30x477	307	480000	63.6	124	1450	329	896
W27x494	391	386000	50.6	108	1340	313	856
W27x448	297	336000	54.1	106	1190	283	766
W27x407	225	291000	57.9	104	1050	255	688

Table 2.1.2 Torsion Properties -- Steel Sections 1971-2000

Designation	Torsional Constant	Warping Constant	$(EC_w/GJ)^{1/2} =$	Normalized Warping Constant	Warping Statical Moment	Statical Moment	Statical Moment
	J	C_w	a	W_{no}	S_w	Q_f	Q_w
	in. ⁴	in. ⁶	in.	in. ²	in. ⁴	in. ³	in. ³
W24x492	456	283000	40.1	92.1	1150	281	774
W24x450	357	247000	42.4	90.1	1030	257	703
W24x408	271	214000	45.2	88.1	909	233	626
W21x402	297	165000	37.9	76.7	805	210	564
W21x364	225	142000	40.4	75.0	709	189	505
W21x333	174	124000	42.9	73.5	632	172	457
W21x300	130	107000	46.2	71.9	556	154	408
W21x275	101	94100	49.1	70.7	499	141	370
W21x248	75.2	81800	53.0	69.5	441	127	331
W21x223	54.9	70600	57.6	68.3	388	113	295
W18x311	177	75700	33.3	58.8	483	141	376
W18x283	135	65600	35.5	57.5	427	127	338
W18x258	104	57400	37.8	56.4	382	116	306
W18x234	79.7	49900	40.3	55.2	339	105	274
W18x211	59.3	43200	43.4	54.2	299	94.3	245
W18x192	45.2	37900	46.6	53.3	267	85.7	221
M14x18	0.11	124	54.0	13.7	3.71	3.60	12.4
M6x20	0.30	91.6	28.0	8.34	4.69	3.03	7.18
M4x13	0.21	11.1	11.7	3.57	1.31	1.24	2.99
S7x20	0.45	34.6	14.1	6.38	2.41	2.29	7.26
S7x15.3	0.24	28.8	17.6	6.05	2.17	2.29	6.12
S5x14.75	0.32	9.12	8.59	3.84	1.03	1.11	3.72
HP13x100	6.25	11274	68.3	40.9	103	29.5	75.5
HP13x87	4.12	9433	77.0	40.2	87.7	25.4	64.8
HP13x73	2.54	7684	88.5	39.6	72.8	21.4	54.3
HP13x60	1.39	6019	106	39.0	57.8	17.3	43.6

Table 2.1.3 Producers -- Steel Sections 1971-2000

Section	Footweight	Producer Code*	
W44	All	T	* Producers: B - Bethlehem Steel Corp. C - C F & I Steel Corp. I - Inland Steel Co. N - Northwestern Steel & Wire Co. U - United States Steel Corp. T - TradeARBED W - Weirton Steel Div., National Steel Corp.
W40	All	T	
W36	All	T	
W33	All	T	
W30	All	T	
W27	All	T	
W24	All	T	
W21	All	T	
W18	311-258	B	
W18	234-192	B, W	
M14	18	N	
M6	20	U	
M4	13	I	
S7	20	C	
S7	15.3	B,I	
S5	14.75	C	
HP13	100-60	I	

Table 2.2.1 Dimensions and Primary Properties -- Steel Sections 1953-1970

Designation	Wt. per ft lb	Area		Depth		Web Thickness			Flange Width		Flange Thickness		Distance		
		A	d	d	tw	tw	tw/2	bf	bf	tf	tf	T	k	k1	
		in.2	in.	in.	in.	in.	in.	in.	in.	in.	in.	in.	in.	in.	in.
W33x240	240	70.60	33.50	33 1/2	0.830	13/16	7/16	15.865	15 7/8	1.400	1 3/8	28 5/8	2 7/16	1 3/8	
W33x220	220	64.80	33.25	33 1/4	0.775	3/4	3/8	15.810	15 3/4	1.275	1 1/4	28 5/8	2 5/16	1 3/8	
W33x200	200	58.90	33.00	33	0.715	11/16	3/8	15.750	15 3/4	1.150	1 1/8	28 5/8	2 3/16	1 3/8	
W30x210	210	61.90	30.38	30 3/8	0.775	3/4	3/8	15.105	15 1/8	1.315	1 5/16	25 3/4	2 5/16	1 5/16	
W30x190	190	56.00	30.12	30 1/8	0.710	11/16	3/8	15.040	15	1.185	1 3/16	25 3/4	2 3/16	1 5/16	
W30x172	172	50.70	29.88	29 7/8	0.655	5/8	5/16	14.985	15	1.065	1 1/16	25 3/4	2 1/16	1 1/4	
W27x177	177	52.20	27.31	27 1/4	0.725	3/4	3/8	14.090	14 1/8	1.190	1 3/16	23	2 1/8	1 1/4	
W27x160	160	47.10	27.08	27 1/8	0.658	11/16	5/16	14.023	14	1.075	1 1/16	23	2 1/16	1 1/4	
W27x145	145	42.70	26.88	26 7/8	0.600	5/8	5/16	13.965	14	0.975	1	23	1 15/16	1 3/16	
W24x160	160	47.10	24.72	24 3/4	0.656	5/8	5/16	14.091	14 1/8	1.135	1 1/8	20 7/8	1 15/16	1 1/16	
W24x145	145	42.70	24.49	24 1/2	0.608	5/8	5/16	14.043	14	1.020	1	20 7/8	1 13/16	1 1/16	
W24x130	130	38.30	24.25	24 1/4	0.565	9/16	5/16	14.000	14	0.900	7/8	20 7/8	1 11/16	1	
W24x120	120	35.40	24.31	24 1/4	0.556	9/16	1/4	12.088	12 1/8	0.930	15/16	20 7/8	1 11/16	1	
W24x110	110	32.50	24.16	24 1/8	0.510	1/2	1/4	12.042	12	0.855	7/8	20 7/8	1 5/8	1	
W24x100	100	29.50	24.00	24	0.468	7/16	1/4	12.000	12	0.775	3/4	20 7/8	1 9/16	15/16	
W24x61	61	18.00	23.72	23 3/4	0.419	7/16	3/16	7.023	7	0.591	9/16	21	1 3/8	15/16	
21WF55	55	16.18	20.80	20 3/4	0.375	3/8	3/16	8.215	8 1/4	0.522	1/2	18 5/8	1 3/16	3/4	
W18x114	114	33.50	18.48	18 1/2	0.595	5/8	5/16	11.833	11 7/8	0.991	1	15 1/8	1 11/16	15/16	
W18x105	105	30.90	18.32	18 3/8	0.554	9/16	1/4	11.792	11 3/4	0.911	15/16	15 1/8	1 5/8	15/16	
W18x96	96	28.20	18.16	18 1/8	0.512	1/2	1/4	11.750	11 3/4	0.831	13/16	15 1/8	1 1/2	7/8	
W18x85	85	25.00	18.32	18 3/8	0.526	1/2	1/4	8.838	8 7/8	0.911	15/16	15 1/8	1 5/8	7/8	
W18x77	77	22.70	18.16	18 1/8	0.475	1/2	1/4	8.787	8 3/4	0.831	13/16	15 1/8	1 1/2	7/8	
W18x70	70	20.60	18.00	18	0.438	7/16	1/4	8.750	8 3/4	0.751	3/4	15 1/8	1 7/16	7/8	
W18x64	64	18.90	17.87	17 7/8	0.403	3/8	3/16	8.715	8 3/4	0.686	11/16	15 1/8	1 3/8	13/16	
W18x45	45	13.20	17.86	17 7/8	0.335	5/16	3/16	7.477	7 1/2	0.499	1/2	15 7/8	1	5/8	
W16x96	96	28.20	16.32	16 3/8	0.535	9/16	1/4	11.533	11 1/2	0.875	7/8	13 1/8	1 5/8	7/8	
W16x88	88	25.90	16.16	16 1/8	0.504	1/2	1/4	11.502	11 1/2	0.795	13/16	13 1/8	1 1/2	7/8	
W16x78	78	23.00	16.32	16 3/8	0.529	1/2	1/4	8.586	8 5/8	0.875	7/8	13 1/8	1 5/8	7/8	
W16x71	71	20.90	16.16	16 1/8	0.486	1/2	1/4	8.543	8 1/2	0.795	13/16	13 1/8	1 1/2	7/8	
W16x64	64	18.80	16.00	16	0.443	7/16	1/4	8.500	8 1/2	0.715	11/16	13 1/8	1 7/16	7/8	
W16x58	58	17.10	15.86	15 7/8	0.407	7/16	3/16	8.464	8 1/2	0.645	5/8	13 1/8	1 3/8	13/16	
W14x314	314	92.30	17.19	17 1/4	1.415	1 7/16	11/16	16.235	16 1/4	2.283	2 5/16	11 1/4	3	1 5/16	
W14x287	287	84.40	16.81	16 3/4	1.310	1 5/16	5/8	16.130	16 1/8	2.093	2 1/16	11 1/4	2 3/4	1 5/16	
W14x264	264	77.60	16.50	16 1/2	1.205	1 3/16	5/8	16.025	16	1.938	1 15/16	11 1/4	2 5/8	1 1/4	
W14x246	246	72.30	16.25	16 1/4	1.125	1 1/8	9/16	15.945	16	1.813	1 13/16	11 1/4	2 1/2	1 3/16	
W14x237	237	69.70	16.12	16 1/8	1.090	1 1/16	9/16	15.910	15 7/8	1.748	1 3/4	11 1/4	2 7/16	1 3/16	
W14x228	228	67.10	16.00	16	1.045	1 1/16	1/2	15.865	15 7/8	1.688	1 11/16	11 1/4	2 3/8	1 1/8	
W14x219	219	64.40	15.87	15 7/8	1.005	1	1/2	15.825	15 7/8	1.623	1 5/8	11 1/4	2 5/16	1 1/8	
W14x202	202	59.40	15.63	15 3/4	0.930	15/16	7/16	15.750	15 3/4	1.503	1 1/2	11 1/4	2 3/16	1 1/8	
W14x184	184	54.10	15.38	15 3/8	0.840	13/16	7/16	15.660	15 5/8	1.378	1 3/8	11 1/4	2 1/16	1 1/16	
W14x167	167	49.10	15.12	15 1/8	0.780	3/4	3/8	15.600	15 5/8	1.248	1 1/4	11 1/4	1 15/16	1	
W14x158	158	46.50	15.00	15	0.730	3/4	3/8	15.550	15 1/2	1.188	1 3/16	11 1/4	1 7/8	1	
W14x150	150	44.10	14.88	14 7/8	0.695	11/16	3/8	15.515	15 1/2	1.128	1 1/8	11 1/4	1 13/16	1	
W14x142	142	41.80	14.75	14 3/4	0.680	11/16	5/16	15.500	15 1/2	1.063	1 1/16	11 1/4	1 3/4	1	
W14x320	320	94.10	16.81	16 3/4	1.890	1 7/8	15/16	16.710	16 3/4	2.093	2 1/16	11 1/4	2 3/4	1 9/16	
W14x136	136	40.00	14.75	14 3/4	0.660	11/16	5/16	14.740	14 3/4	1.063	1 1/16	11 1/4	1 3/4	15/16	
W14x127	127	37.30	14.62	14 5/8	0.610	5/8	5/16	14.690	14 3/4	0.998	1	11 1/4	1 11/16	15/16	
W14x119	119	35.00	14.50	14 1/2	0.570	9/16	5/16	14.650	14 5/8	0.938	15/16	11 1/4	1 5/8	15/16	
W14x111	111	32.70	14.37	14 3/8	0.540	9/16	1/4	14.620	14 5/8	0.873	7/8	11 1/4	1 9/16	7/8	
W14x103	103	30.30	14.25	14 1/4	0.495	1/2	1/4	14.575	14 5/8	0.813	13/16	11 1/4	1 1/2	7/8	
W14x95	95	27.90	14.12	14 1/8	0.465	7/16	1/4	14.545	14 1/2	0.748	3/4	11 1/4	1 7/16	7/8	
W14x87	87	25.60	14.00	14	0.420	7/16	3/16	14.500	14 1/2	0.688	11/16	11 1/4	1 3/8	13/16	
W14x84	84	24.70	14.18	14 1/8	0.451	7/16	1/4	12.023	12	0.778	3/4	11 1/4	1 7/16	7/8	
W14x78	78	22.90	14.06	14	0.428	7/16	3/16	12.000	12	0.718	11/16	11 1/4	1 3/8	7/8	
W12x161	161	47.40	13.88	13 7/8	0.905	7/8	7/16	12.515	12 1/2	1.486	1 1/2	9 1/2	2 3/16	1 1/16	
W12x133	133	39.10	13.38	13 3/8	0.755	3/4	3/8	12.365	12 3/8	1.236	1 1/4	9 1/2	1 15/16	1	
W12x99	99	29.10	12.75	12 3/4	0.582	9/16	5/16	12.192	12 1/4	0.921	15/16	9 1/2	1 5/8	15/16	
W12x92	92	27.10	12.62	12 5/8	0.545	9/16	1/4	12.155	12 1/8	0.856	7/8	9 1/2	1 9/16	7/8	
W12x85	85	25.00	12.50	12 1/2	0.495	1/2	1/4	12.105	12 1/8	0.796	13/16	9 1/2	1 1/2	7/8	
W12x36	36	10.60	12.24	12 1/4	0.305	5/16	1/8	6.565	6 5/8	0.540	9/16	10 1/8	1 1/16	5/8	
W12x31	31	9.13	12.09	12 1/8	0.265	1/4	1/8	6.525	6 1/2	0.465	7/16	10 1/8	1	5/8	
W12x27	27	7.95	11.96	12	0.237	1/4	1/8	6.497	6 1/2	0.400	3/8	10 1/8	15/16	9/16	
W12x16.5	16.5	4.87	12.00	12	0.230	1/4	1/8	4.000	4	0.269	1/4	10 3/8	13/16	9/16	
W10x89	89	26.20	10.88	10 7/8	0.615	5/8	5/16	10.275	10 1/4	0.998	1	7 3/4	1 9/16	13/16	

Table 2.2.1 Dimensions and Primary Properties -- Steel Sections 1953-1970

Designation	Compact Section Criteria			Elastic Properties									Plastic Modulus	
	bf/2tf	h/tw	Fy" ksi	X1 ksi	X2 x 106 (1/ksi)2	Axis x-x			Axis y-y			Zx in.3	Zy in.3	
						lx	Sx	rx	ly	Sy	ry			
						in.4	in.3	in.	in.4	in.3	in.			
W33x240	5.67	34.5	41	2503	4047	13600	813	13.9	933	118	3.64	919	182	
W33x220	6.20	36.9	36	2306	5644	12300	742	13.8	841	106	3.6	838	164	
W33x200	6.85	40.0	31	2103	8170	11100	671	13.7	750	95.2	3.57	756	147	
W30x210	5.74	33.2	43	2583	3517	9890	651	12.6	757	100	3.5	735	155	
W30x190	6.35	36.3	37	2350	5122	8850	587	12.6	673	89.5	3.47	661	138	
W30x172	7.04	39.3	32	2131	7535	7910	530	12.5	598	79.8	3.43	594	123	
W27x177	5.92	31.8	47	2625	3284	6740	494	11.4	556	78.9	3.26	557	122	
W27x160	6.52	34.9	39	2378	4831	6030	446	11.3	495	70.6	3.24	501	109	
W27x145	7.16	38.3	33	2167	6959	5430	404	11.3	443	63.5	3.22	453	97.6	
W24x160	6.21	31.8	47	2696	2792	5120	414	10.4	530	75.2	3.35	465	115	
W24x145	6.88	34.3	41	2450	4107	4570	373	10.3	471	67.1	3.32	417	103	
W24x130	7.78	36.9	36	2197	6378	4020	332	10.2	412	58.9	3.28	370	90.2	
W24x120	6.50	37.7	35	2283	5743	3650	300	10.2	274	45.4	2.78	338	69.9	
W24x110	7.04	41.0	29	2100	7926	3330	276	10.1	249	41.4	2.77	309	63.6	
W24x100	7.74	44.6	25	1919	11342	3000	250	10.1	223	37.2	2.75	280	57.2	
W24x61	5.94	50.6	21	1683	26114	1540	130	9.25	34.3	9.76	1.38	152	15.6	
21WF55	7.87	49.1	27	1647	24897	1140.7	109.7	8.4	44.0	10.7	1.65	124	18.3	
W18x114	5.97	25.4	-	3183	1419	2040	220	7.79	274	46.3	2.86	248	70.9	
W18x105	6.47	27.2	60	2946	1932	1850	202	7.75	249	42.3	2.84	227	64.7	
W18x96	7.07	29.6	53	2705	2671	1680	185	7.7	225	38.3	2.82	206	58.5	
W18x85	4.85	28.7	54	2990	1970	1440	157	7.57	105	23.8	2.05	178	36.8	
W18x77	5.29	31.9	45	2740	2792	1290	142	7.54	94.1	21.4	2.04	161	33.1	
W18x70	5.83	34.5	39	2492	4030	1160	129	7.5	84	19.2	2.02	145	29.6	
W18x64	6.35	37.5	34	2290	5648	1050	118	7.46	75.8	17.4	2	132	26.8	
W18x45	7.49	47.3	23	1736	18958	706	79	7.3	34.8	9.32	1.62	89.7	14.5	
W16x96	6.59	24.4	-	3179	1385	1360	166	6.93	224	38.8	2.82	186	59.3	
W16x88	7.23	26.1	64	2931	1923	1220	151	6.87	202	35.1	2.79	169	53.6	
W16x78	4.91	24.7	-	3290	1348	1050	128	6.75	92.5	21.6	2.01	146	33.4	
W16x71	5.37	27.1	60	3014	1902	941	116	6.71	82.8	19.4	1.99	132	30.0	
W16x64	5.94	29.6	51	2717	2868	836	104	6.66	73.3	17.3	1.97	118	26.6	
W16x58	6.56	32.2	44	2468	4196	748	94.4	6.62	65.3	15.4	1.96	106	23.8	
W14x314	3.56	7.9	-	8889	23.7	4400	512	6.9	1630	201	4.2	611	307	
W14x287	3.85	8.6	-	8220	31.9	3910	465	6.81	1470	182	4.17	551	278	
W14x264	4.13	9.3	-	7628	42.4	3530	427	6.74	1330	166	4.14	502	254	
W14x246	4.40	10.0	-	7159	53.7	3230	397	6.68	1230	154	4.12	464	235	
W14x237	4.55	10.3	-	6923	61.6	3080	382	6.65	1170	148	4.11	445	225	
W14x228	4.70	10.8	-	6681	70.3	2940	368	6.62	1120	142	4.1	427	216	
W14x219	4.88	11.2	-	6429	81.3	2800	353	6.59	1070	136	4.08	408	207	
W14x202	5.24	12.1	-	5974	107	2540	325	6.54	980	124	4.06	373	189	
W14x184	5.68	13.4	-	5476	149	2270	296	6.49	883	113	4.04	338	171	
W14x167	6.25	14.4	-	5017	210	2020	267	6.42	790	101	4.01	303	154	
W14x158	6.54	15.4	-	4765	256	1900	253	6.4	745	95.8	4	286	145	
W14x150	6.88	16.2	-	4527	311	1790	240	6.37	703	90.6	3.99	270	137	
W14x142	7.29	16.5	-	4297	382	1670	227	6.32	660	85.2	3.97	255	129	
W14x320	3.99	6.0	-	9220	22.3	4140	493	6.63	1640	196	4.17	592	304	
W14x136	6.93	17.0	-	4307	382	1590	216	6.31	568	77	3.77	243	117	
W14x127	7.36	18.4	-	4033	490	1480	202	6.29	528	71.8	3.76	226	109	
W14x119	7.81	19.7	-	3801	618	1370	189	6.26	492	67.1	3.75	211	102	
W14x111	8.37	20.8	-	3558	803	1270	176	6.23	455	62.2	3.73	196	94.3	
W14x103	8.96	22.7	-	3297	1065	1170	164	6.21	420	57.6	3.72	181	87.2	
W14x95	9.72	24.2	-	3049	1450	1060	151	6.17	384	52.8	3.71	166	79.9	
W14x87	10.54	26.8	59	2816	1986	967	138	6.15	350	48.2	3.7	151	73.0	
W14x84	7.73	25.1	-	3190	1263	928	131	6.13	225	37.5	3.02	145	57.0	
W14x78	8.36	26.4	61	2971	1676	851	121	6.09	207	34.5	3	134	52.4	
W12x161	4.21	10.0	-	6868	65	1540	222	5.7	486	77.7	3.2	259	119	
W12x133	5.00	11.9	-	5739	127	1220	183	5.59	390	63.1	3.16	210	96.2	
W12x99	6.62	16.3	-	4367	367	859	135	5.43	278	45.7	3.09	152	69.5	
W12x92	7.10	17.4	-	4087	478	789	125	5.4	256	42.2	3.08	140	64.2	
W12x85	7.60	19.2	-	3781	639	723	116	5.38	235	38.9	3.07	129	59.1	
W12x36	6.08	33.2	41	2582	3353	281	46	5.15	25.5	7.77	1.55	51.6	11.9	
W12x31	7.02	38.1	32	2242	5837	239	39.5	5.12	21.6	6.61	1.54	44.1	10.1	
W12x27	8.12	42.6	26	1955	10108	204	34.2	5.07	18.3	5.63	1.52	38.0	8.62	
W12x16.5	7.43	45.1	24	1680	27123	105	17.6	4.65	2.88	1.44	0.77	20.6	2.32	
W10x89	5.15	12.6	-	5718	129	542	99.7	4.55	181	35.2	2.63	114	53.6	

Table 2.2.1 Dimensions and Primary Properties -- Steel Sections 1953-1970

Designation	Wt. per ft lb	Area	Depth			Web Thickness			Flange Width		Flange Thickness		Distance		
		A	d	d	tw	tw	tw/2	bf	bf	tf	tf	T	k	k1	
		in.2	in.	in.	in.	in.	in.	in.	in.	in.	in.	in.	in.	in.	in.
W10x72	72	21.20	10.50	10 1/2	0.510	1/2	1/4	10.170	10 1/8	0.808	13/16	7 3/4	1 3/8	13/16	
W10x66	66	19.40	10.38	10 3/8	0.457	7/16	1/4	10.117	10 1/8	0.748	3/4	7 3/4	1 5/16	3/4	
W10x29	29	8.54	10.22	10 1/4	0.289	5/16	1/8	5.799	5 3/4	0.500	1/2	8 1/8	1 1/16	5/8	
W10x25	25	7.36	10.08	10 1/8	0.252	1/4	1/8	5.762	5 3/4	0.430	7/16	8 1/8	1	5/8	
W10x21	21	6.20	9.90	9 7/8	0.240	1/4	1/8	5.750	5 3/4	0.340	5/16	8 1/8	7/8	9/16	
W10x11.5	11.5	3.39	9.87	9 7/8	0.180	3/16	1/16	3.950	4	0.204	3/16	8 3/8	3/4	9/16	
W8x20	20	5.89	8.14	8 1/8	0.248	1/4	1/8	5.268	5 1/4	0.378	3/8	6 3/8	7/8	9/16	
W8x17	17	5.01	8.00	8	0.230	1/4	1/8	5.250	5 1/4	0.308	5/16	6 3/8	13/16	1/2	
W6x15.5	15.5	4.56	6.00	6	0.235	1/4	1/8	5.995	6	0.269	1/4	4 1/2	3/4	1/2	
W6x8.5	8.5	2.51	5.83	5 7/8	0.170	3/16	1/16	3.940	4	0.194	3/16	4 1/2	11/16	1/2	
W5x18.5	18.5	5.43	5.12	5 1/8	0.265	1/4	1/8	5.025	5	0.420	7/16	3 1/2	13/16	1/2	
M14x17.2	17.2	5.05	14.00	14	0.210	3/16	1/8	4.000	4	0.272	1/4	12 3/4	5/8	3/8	
M10x29.1	29.1	8.56	9.88	9 7/8	0.427	7/16	3/16	5.937	5 7/8	0.389	3/8	8 1/8	7/8	1/2	
10M25	25	7.35	9.90	9 7/8	0.350	3/8	3/16	5.860	5 7/8	0.375	3/8	8	15/16	11/16	
M10x22.9	22.9	6.73	9.88	9 7/8	0.242	1/4	1/8	5.752	5 3/4	0.389	3/8	8 1/8	7/8	7/16	
10M21	21	6.18	9.90	9 7/8	0.240	1/4	1/8	5.740	5 3/4	0.375	3/8	8 3/8	3/4	5/8	
M8x37.7	37.7	11.10	8.12	8 1/8	0.377	3/8	3/16	8.002	8	0.521	1/2	6 1/8	1	1/2	
M8x34.3	34.3	10.10	8.00	8	0.378	3/8	3/16	8.003	8	0.459	7/16	5 7/8	1 1/16	5/8	
M8x32.6	32.6	9.58	8.00	8	0.315	5/16	3/16	7.940	8	0.459	7/16	5 7/8	1 1/16	5/8	
8M28	28	8.23	8.00	8	0.390	3/8	3/16	6.650	6 5/8	0.375	3/8	6 1/4	7/8	11/16	
M8x22.5	22.5	6.60	8.00	8	0.375	3/8	3/16	5.395	5 3/8	0.353	3/8	6 1/4	7/8	1/2	
M8x18.5	18.5	5.44	8.00	8	0.230	1/4	1/8	5.250	5 1/4	0.353	3/8	6 1/4	7/8	7/16	
M7x5.5	5.5	1.62	7.00	7	0.128	1/8	1/16	2.080	2 1/8	0.180	3/16	6 1/8	7/16	1/4	
M6x33.75	33.75	9.93	6.25	6 1/4	0.488	1/2	1/4	6.114	6 1/8	0.605	5/8	4 1/8	1 1/16	9/16	
M6x22.5	22.5	6.62	6.00	6	0.372	3/8	3/16	6.060	6	0.379	3/8	4 3/8	13/16	1/2	
M6x20	20	5.89	6.00	6	0.250	1/4	1/8	5.938	6	0.379	3/8	4 3/8	13/16	7/16	
M6x4.4	4.4	1.29	6.00	6	0.114	1/8	1/16	1.844	1 7/8	0.171	3/16	5 1/4	3/8	1/4	
M4x16.3	16.3	4.80	4.20	4 1/4	0.312	5/16	1/8	3.938	4	0.472	1/2	2 3/8	15/16	1/2	
M4x13.8	13.8	4.06	4.00	4	0.313	5/16	3/16	4.000	4	0.371	3/8	2 3/8	13/16	1/2	
M4x13	13	3.81	4.00	4	0.254	1/4	1/8	3.940	4	0.371	3/8	2 3/8	13/16	7/16	
16B31	31	9.12	15.84	15 7/8	0.275	1/4	1/8	5.525	5 1/2	0.442	7/16	14	15/16	9/16	
16B26	26	7.65	15.65	15 5/8	0.250	1/4	1/8	5.500	5 1/2	0.345	3/8	14	13/16	9/16	
14B26	26	7.65	13.89	13 7/8	0.255	1/4	1/8	5.025	5	0.418	7/16	12 1/8	7/8	9/16	
14B22	22	6.47	13.72	13 3/4	0.230	1/4	1/8	5.000	5	0.335	5/16	12 1/8	13/16	9/16	
14B17.2	17.2	5.05	14.00	14	0.210	3/16	1/8	4.000	4	0.272	1/4	12 7/8	9/16	7/16	
S24x120	120	35.30	24.00	24	0.798	13/16	3/8	8.048	8	1.102	1 1/8	20	2	-	
S24x105.9	105.9	31.10	24.00	24	0.625	5/8	5/16	7.875	7 7/8	1.102	1 1/8	20	2	-	
S24x79.9	79.9	23.50	24.00	24	0.501	1/2	1/4	7.001	7	0.871	7/8	20 1/2	1 3/4	-	
S20x95	95	27.90	20.00	20	0.800	13/16	3/8	7.200	7 1/4	0.916	15/16	16 1/4	1 7/8	-	
S20x85	85	25.00	20.00	20	0.653	5/8	5/16	7.053	7	0.916	15/16	16 1/4	1 7/8	-	
S20x65.4	65.4	19.20	20.00	20	0.500	1/2	1/4	6.250	6 1/4	0.789	13/16	16 3/4	1 5/8	-	
S7x20	20	5.88	7.00	7	0.450	7/16	1/4	3.860	3 7/8	0.392	3/8	5 1/4	7/8	-	
S7x15.3	15.3	4.50	7.00	7	0.252	1/4	1/8	3.662	3 5/8	0.392	3/8	5 1/4	7/8	-	
S5x14.75	14.75	4.34	5.00	5	0.494	1/2	1/4	3.284	3 1/4	0.326	5/16	3 1/2	3/4	-	

Table 2.2.1 Dimensions and Primary Properties -- Steel Sections 1953-1970

Designation	Compact Section Criteria			Elastic Properties									Plastic Modulus	
	bf/2tf	h/tw	Fy" ksi	X1 ksi	X2 x 106 (1/ksi)2	Axis x-x			Axis y-y			Zx in.3	Zy in.3	
						lx	Sx	rx	ly	Sy	ry			
						in.4	in.3	in.	in.4	in.3	in.			
W10x72	6.29	15.2	-	4699	276	421	80.1	4.46	142	27.9	2.59	90.6	42.4	
W10x66	6.76	17.0	-	4327	377	382	73.7	4.44	129	25.5	2.58	82.8	38.8	
W10x29	5.80	28.0	53	2890	2126	158	30.8	4.3	16.3	5.61	1.38	34.7	8.62	
W10x25	6.70	32.1	41	2503	3759	133	26.5	4.26	13.7	4.76	1.37	29.6	7.30	
W10x21	8.46	34.0	39	2125	7613	107	21.5	4.15	10.8	3.75	1.32	24.1	5.77	
W10x11.5	9.68	46.5	22	1554	34235	52	10.5	3.92	2.1	1.06	0.787	12.2	1.68	
W8x20	6.97	25.8	61	2829	2312	69.4	17	3.43	9.22	3.5	1.25	19.1	5.37	
W8x17	8.52	27.7	55	2437	4338	56.6	14.1	3.36	7.44	2.83	1.22	15.9	4.36	
W6x15.5	11.14	19.1	-	2848	2125	30.1	10	2.57	9.67	3.23	1.46	11.1	4.92	
W6x8.5	10.15	26.2	56	2268	5992	14.8	5.08	2.43	1.98	1.01	0.889	5.71	1.55	
W5x18.5	5.98	13.2	-	5098	200	25.4	9.94	2.16	8.89	3.54	1.28	11.3	5.39	
M14x17.2	7.35	60.7	15	1414	55344	147	21.1	5.4	2.65	1.33	0.725	24.8	2.21	
M10x29.1	7.63	19.0	-	3374	1467	131	26.6	3.92	11.2	3.76	1.14	30.9	6.51	
10M25	7.81	22.9	-	2963	2338	117	23.6	3.99	9.84	3.36	1.16	28.3	6.72	
M10x22.9	7.39	33.6	40	2577	3412	117	23.6	4.16	10	3.48	1.22	26.4	5.80	
10M21	7.65	35.0	53	2514	3772	107.5	21.7	4.17	9.3	3.24	1.22	25.5	6.31	
M8x37.7	7.68	16.2	-	4089	491	132	32.6	3.46	40.4	10.1	1.91	36.6	16.0	
M8x34.3	8.72	15.5	-	3779	689	116	29.1	3.4	34.9	8.73	1.86	32.6	13.9	
M8x32.6	8.65	18.7	-	3579	806	114	28.4	3.44	34.1	8.58	1.89	31.6	13.6	
8M28	8.87	16.0	-	3475	1093	90.1	22.5	3.31	17.73	5.33	1.47	25.6	8.57	
M8x22.5	7.64	16.7	-	3678	971	68.2	17.1	3.22	7.48	2.77	1.06	19.7	4.79	
M8x18.5	7.44	27.2	55	2970	1899	62	15.5	3.38	6.82	2.6	1.12	17.4	4.35	
M7x5.5	5.78	47.9	22	1814	19465	12	3.44	2.73	0.249	0.239	0.392	4.03	0.398	
M6x33.75	5.05	8.5	-	6841	68.4	64.7	20.7	2.55	21.4	6.99	1.47	24.1	11.1	
M6x22.5	7.99	11.8	-	4665	318	41.2	13.7	2.49	12.4	4.08	1.37	15.6	6.63	
M6x20	7.83	17.5	-	4059	488	39	13	2.57	11.6	3.9	1.4	14.5	6.25	
M6x4.4	5.39	46.1	-	1895	-	7.2	2.4	2.36	0.165	0.179	0.358	2.80	0.30	
M4x16.3	4.17	7.5	-	7956	36.7	14	6.67	1.71	4.44	2.25	0.962	7.85	3.58	
M4x13.8	5.39	7.6	-	6917	66.2	10.8	5.42	1.63	3.58	1.79	0.939	6.31	2.88	
M4x13	5.31	9.4	-	6501	80.1	10.5	5.24	1.66	3.36	1.71	0.939	6.06	2.74	
16B31	6.25	50.8	25	1767	18742	372.5	47	6.39	11.57	4.19	1.13	53.8	7.03	
16B26	7.97	56.1	20	1502	38032	298.1	38.1	6.24	8.71	3.17	1.07	43.9	5.45	
14B26	6.01	47.6	28	1908	13474	242.6	34.9	5.63	8.26	3.29	1.04	39.9	5.49	
14B22	7.46	52.6	23	1632	26080	197.4	28.8	5.52	6.4	2.56	0.99	33.0	4.36	
14B17.2	7.35	61.3	17	1571	36623	147.3	21	5.4	2.65	1.32	0.72	24.7	2.32	
S24x120	3.65	25.1	-	3403	1565	3030	252	9.26	84.2	20.9	1.54	299	36.4	
S24x105.9	3.57	32.0	-	3051	2142	2830	236	9.53	78.2	19.8	1.58	274	33.5	
S24x79.9	4.02	40.9	29	2455	5442	2110	175	9.47	42.3	12.1	1.34	205	20.7	
S20x95	3.93	20.3	-	3820	1050	1610	161	7.6	49.7	13.8	1.33	194	24.7	
S20x85	3.85	24.9	-	3391	1524	1520	152	7.79	46.2	13.1	1.36	179	22.8	
S20x65.4	3.96	33.5	-	2781	3347	1180.0	118.0	7.84	27.40	8.77	1.19	138	15.2	
S7x20	4.92	11.7	-	5388	251	42.4	12.1	2.69	3.17	1.64	0.73	14.5	2.96	
S7x15.3	4.67	20.8	-	3971	660	36.7	10.5	2.86	2.64	1.44	0.77	12.1	2.44	
S5x14.75	5.04	7.1	-	7783	61.7	15.2	6.09	1.87	1.67	1.01	0.62	7.42	1.88	

Table 2.2.2 Torsion Properties -- Steel Sections 1953-1970

Designation	Torsional Constant	Warping Constant		Normalized Warping Constant	Warping Statical Moment	Statical Moment	Statical Moment
	J	Cw	(ECw/GJ) ^{1/2}	Wno	Sw	Qf	Qw
	in.4	in.6	in.	in.2	in.4	in.3	in.3
W33x240	36.60	240000	130	127	707	169	454
W33x220	28.20	215000	141	126	637	153	414
W33x200	21.10	190000	153	125	568	138	373
W30x210	28.50	160000	121	110	545	137	363
W30x190	21.20	141000	131	109	485	123	326
W30x172	15.70	124000	143	108	431	110	293
W27x177	20.10	94800	111	92.0	386	104	275
W27x160	14.90	83700	121	91.2	344	93.4	247
W27x145	11.20	74300	131	90.4	308	84.4	223
W24x160	16.5	73700	108	83.1	332	89.9	230
W24x145	12.2	64900	117	82.4	295	80.4	206
W24x130	8.67	56200	130	81.7	257	70.6	183
W24x120	8.27	37500	108	70.7	199	62.7	166
W24x110	6.45	33800	116	70.2	181	57.4	152
W24x100	4.87	30100	127	69.7	162	51.9	137
W24x61	1.66	4580	84.5	40.6	42.1	22.6	74.6
21WF55	1.26	4523	96.5	41.6	44.6	20.7	61.8
W18x114	9.13	21000	77.2	51.7	152	48.7	123
W18x105	7.15	18900	82.7	51.3	138	44.6	112
W18x96	5.54	16900	88.9	50.9	124	40.5	102
W18x85	5.50	7960	61.2	38.5	77.4	33.0	88.0
W18x77	4.16	7070	66.3	38.1	69.5	29.9	79.4
W18x70	3.13	6250	71.9	37.7	62.0	26.9	71.6
W18x64	2.41	5600	77.6	37.4	56.0	24.5	65.1
W18x45	0.889	2620	87.4	32.5	30.3	15.5	44.3
W16x96	6.16	13400	75.1	44.5	112	37.2	92.1
W16x88	4.72	11900	80.8	44.2	101	33.6	83.6
W16x78	4.81	5520	54.5	33.2	62.3	27.2	72.1
W16x71	3.65	4890	58.9	32.8	55.7	24.6	65.1
W16x64	2.65	4280	64.7	32.5	49.4	22.0	58.2
W16x58	1.98	3780	70.3	32.2	43.9	19.8	52.3
W14x314	140	90600	40.9	60.5	561	126.1	304
W14x287	108	79400	43.6	59.3	501	114.1	275
W14x264	85.3	70600	46.3	58.3	453	104.6	250
W14x246	69.7	63900	48.7	57.5	416	97.0	231
W14x237	62.6	60700	50.1	57.2	397	93.1	222

Table 2.2.2 Torsion Properties -- Steel Sections 1953-1970

Designation	Torsional Constant	Warping Constant		Normalized Warping Constant	Warping Statical Moment	Statical Moment	Statical Moment
	J	Cw	(ECw/GJ) ^{1/2}	Wno	Sw	Qf	Qw
	in.4	in.6	in.	in.2	in.4	in.3	in.3
W14x228	56.2	57600	51.5	56.8	380	89.5	212
W14x219	49.9	54500	53.2	56.4	362	85.7	203
W14x202	39.6	48900	56.5	55.6	329	78.7	186
W14x184	30.3	43300	60.8	54.8	296	71.5	168
W14x167	22.8	38000	65.7	54.1	263	64.1	151
W14x158	19.5	35500	68.7	53.7	248	60.8	142
W14x150	16.7	33200	71.7	53.3	233	57.5	134
W14x142	14.2	30900	75.1	53.0	218	53.9	126
W14x320	137	88500	40.9	61.5	538	114.1	295
W14x136	13.5	26600	71.4	50.4	198	51.2	120
W14x127	11.1	24500	75.6	50.0	183	47.9	112
W14x119	9.20	22600	79.8	49.7	171	44.8	105
W14x111	7.48	20700	84.6	49.3	157	41.5	96.9
W14x103	6.02	18900	90.2	49.0	145	38.5	89.5
W14x95	4.74	17200	96.9	48.6	132	35.2	82.0
W14x87	3.68	15500	104.4	48.3	120	32.2	74.8
W14x84	4.41	10100	77.0	40.3	94.2	30.2	71.7
W14x78	3.52	9210	82.3	40.0	86.2	27.7	66.0
W12x161	30.6	18700	39.8	38.8	180	53.5	129
W12x133	17.6	14400	46.0	37.5	143	43.6	104
W12x99	7.45	9740	58.2	36.1	101	31.6	75.1
W12x92	6.01	8870	61.8	35.7	93.0	29.2	69.3
W12x85	4.80	8060	65.9	35.4	85.3	27.0	63.7
W12x36	0.830	873	52.2	19.2	17.0	9.89	25.5
W12x31	0.536	728	59.3	19.0	14.4	8.46	21.8
W12x27	0.351	611	67.1	18.8	12.2	7.24	18.7
W12x16.5	0.112	99.2	47.9	11.7	3.16	2.97	10.1
W10x89	7.74	4410	38.4	25.4	65.1	23.8	56.7
W10x72	4.17	3330	45.5	24.6	50.6	18.9	44.9
W10x66	3.27	3000	48.7	24.4	46.1	17.4	41.0
W10x29	0.579	384	41.4	14.1	10.2	6.69	17.2
W10x25	0.373	320	47.1	13.9	8.61	5.72	14.6
W10x21	0.210	246	55.1	13.7	6.72	4.48	11.9
W10x11.5	0.049	49.1	50.9	9.55	1.92	1.86	5.91
W8x20	0.245	139	38.3	10.2	5.09	3.68	9.42
W8x17	0.147	110	44.0	10.1	4.08	2.97	7.79
W6x15.5	0.111	79.4	43.0	8.59	3.46	2.22	5.50
W6x8.5	0.033	15.7	35.1	5.55	1.06	1.03	2.78
W5x18.5	0.295	49.1	20.8	5.90	3.12	2.35	5.57
M14x17.2	0.110	125	54.2	13.7	3.73	3.54	12.2

Table 2.2.2 Torsion Properties -- Steel Sections 1953-1970

Designation	Torsional Constant	Warping Constant		Normalized Warping Constant	Warping Statical Moment	Statical Moment	Statical Moment
	J	Cw	(EC_w/GJ) ^{1/2}	Wno	Sw	Qf	Qw
	in.4	in.6	in.	in.2	in.4	in.3	in.3
M10x29.1	0.587	251	33.3	14.1	8.13	5.09	15.4
10M25	0.415	223	37.3	14.0	7.67	4.92	14.1
M10x22.9	0.343	226	41.3	13.6	7.63	5.09	13.1
10M21	0.301	211	42.6	13.7	7.36	4.91	12.8
M8x37.7	0.999	584	38.9	15.2	15.8	7.55	18.2
M8x34.3	0.747	497	41.5	15.1	13.9	6.60	16.2
M8x32.6	0.673	484	43.2	15.0	13.6	6.60	15.7
8M28	0.463	258	38.0	12.7	7.90	4.47	12.1
M8x22.5	0.374	109	27.5	10.3	4.91	3.39	9.78
M8x18.5	0.243	99.8	32.6	10.0	4.65	3.39	8.62
M7x5.5	0.015	2.89	22.3	3.55	0.33	0.60	1.98
M6x33.75	1.26	170	18.7	8.63	7.98	4.80	12.0
M6x22.5	0.385	97.7	25.6	8.52	4.89	3.03	7.73
M6x20	0.295	91.5	28.3	8.34	4.69	3.03	7.18
M6x4.4	0.010	1.4	19.0	2.69	0.21	0.43	1.38
M4x16.3	0.366	15.4	10.4	3.67	1.71	1.60	3.88
M4x13.8	0.216	11.8	11.9	3.63	1.35	1.24	3.11
M4x13	0.190	11.1	12.3	3.57	1.31	1.24	2.99
16B31	0.472	686	61.3	21.3	13.0	8.93	26.5
16B26	0.267	510	70.3	21.0	10.0	6.93	21.5
14B26	0.362	375	51.8	16.9	8.89	6.72	19.6
14B22	0.213	287	59.0	16.7	7.01	5.35	16.1
14B17.2	0.135	125	49.0	13.7	3.73	3.54	12.2
S24x120	13.00	11000	46.8	46.1	102.1	45.7	148.9
S24x105.9	10.40	10200	50.4	45.1	97.8	45.7	136.5
S24x79.9	4.90	5660	54.7	40.5	61.7	32.7	101.5
S20x95	8.46	4520	37.2	34.4	56.6	28.0	95.9
S20x85	6.63	4200	40.5	33.6	54.3	28.0	88.6
S20x65.4	3.50	2530	43.3	30.0	37.0	21.8	68.6
S7x20	0.451	34.6	14.1	6.38	2.41	2.21	7.17
S7x15.3	0.241	28.8	17.6	6.05	2.17	2.21	5.96
S5x14.75	0.323	9.09	8.54	3.84	1.03	1.06	3.67

Table 2.2.3 Producers -- Steel Sections 1953-1970

Section	Footweight	Producer Code*	Section	Footweight	Producer Code*
W33	All	B, U	M14	17.2	J, N
W30	All	B, U	M10	29.1, 22.9	K
W27	All	B, U	10M	25, 21	P
W24	160-130	B, U	M8	37.7	U
W24	120-61	A, B, I, U	M8	34.3, 32.6	K, U
21WF	55	B, I, U	8M	28	P
W18	114-96	A, B, U	8M	22.5, 18.5	K
W18	85-77	A, B, I, U	M7	5.5	J
W18	70-45	A, B, I, N, U	M6	33.75	U
W16	96-88	A, B, U	M6	22.5	C, K
W16	78-71	A, B, I, U	M6	20	C, K, U, W
W16	64-58	A, B, I, N, U	M6	4.4	J
W14	314-87	B, U	M4	16.3	U
W14	84-78	A, B, I, U	M4	13.8	C, K
W12	161-85	A, B, I, U	M4	13	A, C, I, K, U
W12	36-27	A, B, C, I, N, U, W	16B	31, 26	B, I, N, U
W12	16.5	A, B, C, I, N, U	14B	26, 22	B, I, N, U
W10	89-66	A, B, I, U	14B	17.2	J
W10	29-21	A, B, C, I, N, U, W	S24	120, 105.9	A,B,U
W10	11.5	A, B, C, I, J, N, U	S24	79.9	B, U
W8	20-15.5	A, B, C, I, N, U	S20	95, 85	A,B,U
W8	8.5	A, B, I, N, U	S20	65.4	A,B,K,U
W8	18.5	A, B, C, U	S7	20	B, C, I, U
			S7	15.3	A, B, C, I, U

* Producer Code:

A - Armco Steel Corp.

B - Bethlehem Steel Corp.

C - C F & I Steel Corp.

I - Inland Steel Co.

J - Jones & Laughlin Steel Corp.

K - Kaiser Steel Corp.

N - Northwestern Steel & Wire Co.

P - Phoenix Steel Corp.

U - United States Steel Corp.

W - Weirton Steel Div., National Steel Corp.

Table 2.3.1 Dimensions and Primary Properties -- Steel Sections 1887-1952

Designation	Source Reference Number	Wt. per ft lb	Area	Depth	Web Thickness	Flange Width	Average Flange Thickness	Distance	Distance	Compact Section Criteria		
			A in.2	d in.	t _w in.	b _f in.	t _f in.	T in.	k in.	b _f /2t _f	h/t _w	F _y " ksi
S 24x120	5 10 22	120.0	35.13	24.00	0.798	8.048	1.102	20.064	1.968	3.65	25.1	-
S 24x115	8 12 14 17	115.0	33.98	24.00	0.750	8.000	1.102	20.064	1.968	3.63	26.8	-
S 24x115	4 9 13 18	115.0	33.67	24.00	0.737	7.987	1.102	20.064	1.968	3.62	27.2	-
S 24x110	8 12 14 17	110.0	32.48	24.00	0.688	7.938	1.102	20.064	1.968	3.60	29.2	-
S 24x110	4 9 13 18	110.0	32.18	24.00	0.675	7.925	1.102	20.064	1.968	3.60	29.7	-
S 24x105.9	5 11 13 18 22	105.9	30.98	24.00	0.625	7.875	1.102	20.064	1.968	3.57	32.1	62
S 24x105	8 12 14 17	105.0	30.98	24.00	0.625	7.875	1.102	20.064	1.968	3.57	32.1	62
S 24x100	21	100.0	29.42	24.00	0.620	7.690	0.965	20.271	1.864	3.98	32.7	60
S 24x100	19	100.0	29.42	24.00	0.680	7.540	0.925	20.351	1.824	4.08	29.9	-
S 24x100	1 7 15	100.0	29.41	24.00	0.754	7.254	0.871	20.588	1.706	4.16	27.3	-
S 24x100	8 12 14 17	100.0	29.41	24.00	0.754	7.254	0.871	20.588	1.706	4.16	27.3	-
S 24x100	6	100.0	29.40	24.00	0.746	7.196	0.861	20.546	1.727	4.18	27.5	-
S 24x100	3 11 13 16 18 22	100.0	29.25	24.00	0.747	7.247	0.871	20.588	1.706	4.16	27.6	-
S 24x95	1 7 15	95.0	27.94	24.00	0.692	7.192	0.871	20.588	1.706	4.13	29.8	-
S 24x95	8 12 14 17	95.0	27.94	24.00	0.693	7.193	0.871	20.588	1.706	4.13	29.7	-
S 24x95	19	95.0	27.92	24.00	0.620	7.480	0.925	20.351	1.824	4.04	32.8	60
S 24x95	21	95.0	27.92	24.00	0.590	7.450	0.965	20.271	1.864	3.86	34.4	55
S 24x95	6	95.0	27.90	24.00	0.685	7.135	0.861	20.546	1.727	4.15	30.0	-
S 24x95	2 9 13 16 18	95.0	27.79	24.00	0.686	7.186	0.871	20.588	1.706	4.13	30.0	-
S 24x90	20	90.0	26.47	24.00	0.560	7.420	0.925	20.351	1.824	4.01	36.3	49
S 24x90	1 7 15	90.0	26.47	24.00	0.631	7.131	0.871	20.588	1.706	4.09	32.6	60
S 24x90	8 12 14 17	90.0	26.47	24.00	0.631	7.131	0.871	20.588	1.706	4.09	32.6	60
S 24x90	6	90.0	26.40	24.00	0.623	7.073	0.861	20.546	1.727	4.11	33.0	59
S 24x90	3 11 13 16 18 22	90.0	26.30	24.00	0.624	7.124	0.871	20.588	1.706	4.09	33.0	59
S 24x85	21	85.0	25.00	24.00	0.540	7.220	0.870	20.592	1.704	4.15	38.1	44
S 24x85	1 7 15	85.0	25.00	24.00	0.570	7.070	0.871	20.588	1.706	4.06	36.1	49
S 24x85	8 12 14 17	85.0	25.00	24.00	0.570	7.070	0.871	20.588	1.706	4.06	36.1	49
S 24x85	19	85.0	25.00	24.00	0.560	7.060	0.870	20.592	1.704	4.06	36.8	48
S 24x85	2 9 13 16 18	85.0	24.84	24.00	0.563	7.063	0.871	20.588	1.706	4.05	36.6	48
S 24x85	6	85.0	24.98	24.00	0.562	7.012	0.861	20.546	1.727	4.07	36.6	48
S 24x80	20	80.0	23.53	24.00	0.500	7.000	0.870	20.592	1.704	4.02	41.2	38
S 24x80	6	80.0	23.50	24.00	0.500	6.950	0.861	20.546	1.727	4.04	41.1	38
S 24x80	1 7 15	80.0	23.32	24.00	0.500	7.000	0.871	20.588	1.706	4.02	41.2	38
S 24x80	8 12 17	80.0	23.32	24.00	0.500	7.000	0.871	20.588	1.706	4.02	41.2	38
S 24x79.9	3 11 13 14 16 18 22	79.9	23.33	24.00	0.500	7.000	0.871	20.588	1.706	4.02	41.2	38
S 20x100	12	100.0	29.62	20.00	0.894	7.294	0.915	16.345	1.828	3.99	18.3	-
S 20x100	2 14	100.0	29.50	20.00	0.900	7.300	0.900	16.592	1.704	4.06	18.4	-
S 20x100	20	100.0	29.41	20.00	0.810	7.310	0.965	16.154	1.923	3.79	19.9	-
S 20x100	3 6 9 11 13 16	100.0	29.41	20.00	0.884	7.284	0.917	16.339	1.831	3.97	18.5	-
S 20x100	23	100.0	29.41	20.00	0.894	7.044	0.950	16.205	1.898	3.71	18.1	-
S 20x100	22	100.0	29.41	20.00	0.850	7.030	0.955	16.194	1.903	3.68	19.1	-
S 20x100	24	100.0	29.41	20.00	0.870	7.020	0.950	16.205	1.898	3.69	18.6	-
S 20x100	4 7 10 15	100.0	29.20	20.00	0.873	7.273	0.917	16.339	1.831	3.97	18.7	-
S 20x98.4	19	98.4	28.94	20.00	0.910	7.060	0.860	16.525	1.738	4.10	18.2	-
S 20x95	12	95.0	28.12	20.00	0.820	7.220	0.915	16.345	1.828	3.95	19.9	-
S 20x95	2 14	95.0	28.00	20.00	0.825	7.225	0.900	16.592	1.704	4.01	20.1	-
S 20x95	20	95.0	27.94	20.00	0.740	7.240	0.965	16.154	1.923	3.75	21.8	-
S 20x95	3 6 9 11 13 16	95.0	27.94	20.00	0.810	7.210	0.917	16.339	1.831	3.93	20.2	-
S 20x95	23	95.0	27.94	20.00	0.821	6.971	0.950	16.205	1.898	3.67	19.7	-
S 20x95	24	95.0	27.94	20.00	0.800	6.950	0.950	16.205	1.898	3.66	20.3	-
S 20x95	22	95.0	27.94	20.00	0.770	6.950	0.955	16.194	1.903	3.64	21.0	-
S 20x95	5 8 10 15 27	95.0	27.74	20.00	0.800	7.200	0.917	16.339	1.831	3.93	20.4	-
S 20x90	12	90.0	26.66	20.00	0.747	7.147	0.915	16.345	1.828	3.91	21.9	-
S 20x90	2 14	90.0	26.50	20.00	0.750	7.150	0.900	16.592	1.704	3.97	22.1	-
S 20x90	3 6 9 11 13 16	90.0	26.47	20.00	0.737	7.137	0.917	16.339	1.831	3.89	22.2	-
S 20x90	20	90.0	26.47	20.00	0.780	6.900	0.865	16.414	1.793	3.99	21.0	-
S 20x90	23	90.0	26.47	20.00	0.747	6.897	0.950	16.205	1.898	3.63	21.7	-
S 20x90	24	90.0	26.47	20.00	0.730	6.880	0.950	16.205	1.898	3.62	22.2	-
S 20x90	22	90.0	26.47	20.00	0.700	6.880	0.955	16.194	1.903	3.60	23.1	-
S 20x90	17	90.0	26.40	20.00	0.780	6.750	0.910	16.361	1.820	3.71	21.0	-
S 20x90	4 7 10 15	90.0	26.26	20.00	0.726	7.126	0.917	16.339	1.831	3.89	22.5	-
S 20x85	12	85.0	25.18	20.00	0.673	7.073	0.915	16.345	1.828	3.87	24.3	-
S 20x85	2 14	85.0	25.00	20.00	0.675	7.075	0.900	16.592	1.704	3.93	24.6	-
S 20x85	3 6 9 11 13 16	85.0	25.00	20.00	0.663	7.063	0.917	16.339	1.831	3.85	24.6	-
S 20x85	23	85.0	25.00	20.00	0.674	6.824	0.950	16.205	1.898	3.59	24.0	-
S 20x85	20	85.0	25.00	20.00	0.700	6.820	0.865	16.414	1.793	3.94	23.4	-
S 20x85	24	85.0	25.00	20.00	0.650	6.800	0.950	16.205	1.898	3.58	24.9	-
S 20x85	22	85.0	25.00	20.00	0.680	6.760	0.905	16.334	1.833	3.73	24.0	-
S 20x85	18	85.0	25.00	20.00	0.760	6.450	0.910	16.361	1.820	3.54	21.5	-
S 20x85	5 8 10 15 27	85.0	24.80	20.00	0.653	7.053	0.917	16.339	1.831	3.85	25.0	-
S 20x81.7	19	81.7	24.04	20.00	0.750	6.500	0.765	16.745	1.628	4.25	22.3	-
S 20x81.4	24	81.4	23.94	20.00	0.600	6.750	0.950	16.205	1.898	3.55	27.0	-
S 20x81.4	4 7 10 11 15	81.4	23.74	20.00	0.600	7.000	0.917	16.339	1.831	3.82	27.2	-
S 20x80	12	80.0	23.79	20.00	0.735	6.485	0.790	16.812	1.594	4.10	22.9	-
S 20x80	3 6 9 12 13 16	80.0	23.73	20.00	0.600	7.000	0.917	16.339	1.831	3.82	27.2	-

Table 2.3.1 Dimensions and Primary Properties -- Steel Sections 1887-1952

Designation	X ₁ ksi	X ₂ x 106 (1/ksi) ²	Elastic Properties						Plastic Modulus	
			Axis x-x			Axis y-y			Z _x in.3	Z _y in.3
			I _x	S _x	r _x	I _y	S _y	r _y		
			in.4	in.3	in.	in.4	in.3	in.		
S 24x120	3406	1564	3010.8	250.9	9.26	84.9	21.1	1.56	297.6	36.5
S 24x115	3303	1717	2955.5	246.3	9.33	83.2	20.8	1.57	290.7	35.7
S 24x115	3277	1759	2940.5	245.0	9.35	82.8	20.7	1.57	288.9	35.5
S 24x110	3179	1920	2883.5	240.3	9.42	81.0	20.4	1.58	281.8	34.7
S 24x110	3155	1964	2869.1	239.1	9.44	80.6	20.3	1.58	279.9	34.4
S 24x105.9	3064	2130	2811.5	234.3	9.53	78.9	20.0	1.60	272.7	33.7
S 24x105	3064	2130	2811.5	234.3	9.53	78.9	20.0	1.60	272.7	33.7
S 24x100	2910	3029	2497.3	208.1	9.21	57.5	15.0	1.40	246.2	28.3
S 24x100	2908	3048	2497.3	208.1	9.21	57.5	15.3	1.40	244.2	26.6
S 24x100	3044	2806	2380.3	198.4	9.00	48.6	13.4	1.28	239.4	24.2
S 24x100	3045	2803	2379.6	198.3	9.00	48.6	13.4	1.28	239.4	24.2
S 24x100	3047	2888	2342.7	195.2	8.93	47.0	13.1	1.26	235.7	23.6
S 24x100	3027	2860	2371.8	197.6	9.05	48.4	13.4	1.29	238.4	24.1
S 24x95	2880	3355	2309.6	192.5	9.09	47.1	13.1	1.30	230.4	23.3
S 24x95	2884	3338	2309.0	192.4	9.09	47.1	13.1	1.30	230.6	23.3
S 24x95	2774	3507	2427.0	202.3	9.32	55.9	15.0	1.41	235.5	25.8
S 24x95	2823	3261	2427.0	202.3	9.32	55.9	15.0	1.41	237.3	26.5
S 24x95	2883	3447	2271.9	189.3	9.02	45.6	12.8	1.28	226.9	22.7
S 24x95	2866	3407	2301.5	191.8	9.08	47.0	13.0	1.30	229.6	23.2
S 24x90	2656	3981	2356.8	196.4	9.44	54.4	14.7	1.44	226.9	25.0
S 24x90	2732	3957	2239.1	186.6	9.20	45.7	12.8	1.31	221.6	22.5
S 24x90	2734	3952	2238.4	186.5	9.20	45.7	12.8	1.31	221.6	22.5
S 24x90	2730	4091	2201.0	183.4	9.13	44.3	12.5	1.29	218.0	21.9
S 24x90	2718	4024	2230.1	185.8	9.21	45.5	12.8	1.32	220.6	22.4
S 24x85	2538	4994	2181.7	181.8	9.34	44.1	12.2	1.33	212.0	22.3
S 24x85	2597	4607	2168.6	180.7	9.31	44.4	12.5	1.33	212.9	21.7
S 24x85	2597	4607	2167.8	180.7	9.31	44.4	12.6	1.33	212.9	21.7
S 24x85	2556	4851	2181.7	181.8	9.34	44.1	12.5	1.33	211.3	21.5
S 24x85	2584	4683	2159.8	180.0	9.33	44.2	12.5	1.33	211.9	21.6
S 24x85	2597	4773	2130.2	177.5	9.23	42.9	12.2	1.31	209.2	21.1
S 24x80	2438	5540	2111.4	176.0	9.47	42.8	12.2	1.35	202.6	20.8
S 24x80	2473	5498	2059.3	171.6	9.42	41.6	12.0	1.34	200.3	20.4
S 24x80	2459	5385	2087.9	174.0	9.46	42.9	12.2	1.36	202.8	20.8
S 24x80	2460	5378	2087.2	173.9	9.46	42.9	12.3	1.36	202.8	20.8
S 24x79.9	2461	5378	2087.2	173.9	9.46	42.9	12.2	1.36	202.8	20.8
S 20x100	4136	810	1662.3	166.2	7.49	52.9	14.5	1.34	201.0	26.2
S 20x100	4083	861	1649.2	164.9	7.48	52.8	14.5	1.34	199.9	26.0
S 20x100	4054	872	1649.6	165.0	7.49	55.6	15.2	1.37	200.2	26.7
S 20x100	4105	829	1655.6	165.6	7.50	52.7	14.5	1.34	200.2	26.0
S 20x100	4189	751	1667.6	166.8	7.53	48.9	13.9	1.29	200.5	25.3
S 20x100	4097	838	1649.6	165.0	7.49	55.6	15.8	1.37	197.2	25.1
S 20x100	4151	797	1648.6	164.9	7.49	48.7	13.9	1.29	198.1	24.9
S 20x100	4070	853	1648.3	164.8	7.51	52.4	14.4	1.34	199.1	25.9
S 20x98.4	4133	877	1567.4	156.7	7.36	45.5	12.9	1.25	192.1	23.8
S 20x95	3892	988	1612.6	161.3	7.57	51.0	14.1	1.35	193.6	25.1
S 20x95	3833	1061	1599.2	159.9	7.56	50.8	14.1	1.35	192.4	24.9
S 20x95	3852	1025	1601.9	160.2	7.57	53.6	14.8	1.39	193.2	25.8
S 20x95	3865	1010	1606.6	160.7	7.58	50.8	14.1	1.35	192.8	25.0
S 20x95	3955	906	1618.3	161.8	7.62	47.3	13.6	1.30	193.2	24.2
S 20x95	3930	950	1599.5	160.0	7.57	46.9	13.5	1.30	191.1	23.9
S 20x95	3848	1030	1601.9	160.2	7.57	53.6	15.4	1.39	189.2	24.0
S 20x95	3835	1037	1599.7	160.0	7.59	50.5	14.0	1.35	191.8	24.8
S 20x90	3671	1193	1563.8	156.4	7.66	49.2	13.8	1.36	186.3	24.1
S 20x90	3603	1298	1549.2	154.9	7.65	48.9	13.7	1.36	184.9	23.9
S 20x90	3647	1217	1557.6	155.8	7.67	49.0	13.7	1.36	185.5	24.0
S 20x90	3725	1210	1501.7	150.2	7.53	41.9	12.1	1.26	179.2	21.8
S 20x90	3733	1089	1569.0	156.9	7.71	45.6	13.2	1.32	185.8	23.2
S 20x90	3725	1125	1550.5	155.1	7.65	45.2	13.1	1.31	184.1	23.0
S 20x90	3776	1134	1501.7	150.2	7.53	41.9	12.2	1.26	182.2	23.1
S 20x90	3812	1086	1506.1	150.6	7.55	42.3	12.5	1.27	181.6	22.2
S 20x90	3618	1249	1550.3	155.0	7.68	48.7	13.7	1.36	184.4	23.8
S 20x85	3466	1428	1515.1	151.5	7.76	47.5	13.4	1.37	178.9	23.1
S 20x85	3392	1569	1499.2	149.9	7.74	47.4	13.4	1.38	177.4	23.0
S 20x85	3445	1454	1508.5	150.9	7.77	47.3	13.4	1.37	178.1	23.0
S 20x85	3533	1290	1519.6	152.0	7.80	44.0	12.9	1.33	178.5	22.3
S 20x85	3477	1519	1453.1	145.3	7.62	40.3	11.8	1.27	171.2	20.8
S 20x85	3510	1357	1501.5	150.2	7.75	43.5	12.8	1.32	176.1	22.0
S 20x85	3537	1413	1453.1	145.3	7.62	40.3	11.9	1.27	172.9	21.2
S 20x85	3889	1049	1394.1	139.4	7.50	34.2	10.6	1.17	174.8	20.4
S 20x85	3420	1487	1501.7	150.2	7.78	47.0	13.3	1.38	177.1	22.9
S 20x81.7	3556	1592	1312.5	131.2	7.39	31.4	9.7	1.14	159.5	17.6
S 20x81.4	3390	1501	1466.2	146.6	7.83	42.4	12.6	1.33	171.1	21.4
S 20x81.4	3291	1668	1466.3	146.6	7.86	45.8	13.1	1.39	171.8	22.3
S 20x80	3486	1647	1326.4	132.6	7.46	31.7	9.8	1.15	160.7	17.8
S 20x80	3290	1668	1466.3	146.6	7.86	45.8	13.1	1.39	171.8	22.3

Table 2.3.1 Dimensions and Primary Properties -- Steel Sections 1887-1952

Designation	Source Reference Number	Wt. per ft lb	Area	Depth	Web Thickness	Flange Width	Average Flange Thickness	Distance	Distance	Compact Section Criteria		
			A	d	t _w	b _f	t _f	T	k	b _f /2t _f	h/t _w	F _y "
			in.2	in.	in.	in.	in.	in.	in.	in.		
S 20x80	21	80.0	23.53	20.00	0.630	6.750	0.865	16.414	1.793	3.90	26.1	-
S 20x80	28	80.0	23.53	20.00	0.600	6.750	0.950	16.205	1.898	3.55	27.0	-
S 20x80	1 2 14	80.0	23.50	20.00	0.600	7.000	0.900	16.592	1.704	3.89	27.7	-
S 20x80	17	80.0	23.50	20.00	0.690	6.380	0.840	16.688	1.656	3.80	24.2	-
S 20x78	19	78.0	22.94	20.00	0.600	6.750	0.860	16.525	1.738	3.92	27.5	-
S 20x75	12	75.0	22.32	20.00	0.662	6.412	0.790	16.812	1.594	4.06	25.4	-
S 20x75	2	75.0	22.10	20.00	0.665	6.415	0.765	16.912	1.544	4.19	25.4	-
S 20x75	17	75.0	22.10	20.00	0.660	6.160	0.805	16.782	1.609	3.83	25.4	-
S 20x75	3 6 9 11 13 14 16 23	75.0	22.06	20.00	0.649	6.399	0.790	16.814	1.593	4.05	25.9	-
S 20x75	21	75.0	22.06	20.00	0.640	6.390	0.790	16.812	1.594	4.04	26.3	-
S 20x75	24	75.0	22.06	20.00	0.640	6.390	0.790	16.814	1.593	4.05	26.3	-
S 20x75	5 8 10 15 25 26 27	75.0	21.90	20.00	0.641	6.391	0.790	16.814	1.593	4.05	26.2	-
S 20x70	12	70.0	20.84	20.00	0.588	6.338	0.790	16.812	1.594	4.01	28.6	-
S 20x70	2	70.0	20.60	20.00	0.590	6.340	0.765	16.912	1.544	4.14	28.7	-
S 20x70	18	70.0	20.60	20.00	0.570	6.070	0.805	16.782	1.609	3.77	29.4	-
S 20x70	3 6 9 11 13 14 16 23	70.0	20.59	20.00	0.575	6.325	0.790	16.814	1.593	4.01	29.2	-
S 20x70	24	70.0	20.59	20.00	0.570	6.320	0.790	16.814	1.593	4.00	29.5	-
S 20x70	20	70.0	20.59	20.00	0.560	6.310	0.790	16.812	1.594	3.99	30.0	-
S 20x70	22	70.0	20.59	20.00	0.570	6.270	0.790	16.812	1.594	3.97	29.5	-
S 20x70	4 7 10 15 25	70.0	20.42	20.00	0.567	6.317	0.790	16.814	1.593	4.00	29.7	-
S 20x66.67	2	66.67	19.60	20.00	0.540	6.290	0.765	16.912	1.544	4.11	31.3	-
S 20x65.4	24	65.4	19.24	20.00	0.500	6.250	0.790	16.814	1.593	3.96	33.6	57
S 20x65.4	5 8 10 11 15 25 26 27	65.4	19.08	20.00	0.500	6.250	0.790	16.814	1.593	3.96	33.6	57
S 20x65	21	65.0	19.12	20.00	0.500	6.250	0.790	16.812	1.594	3.96	33.6	57
S 20x65	17	65.0	19.10	20.00	0.500	6.000	0.805	16.782	1.609	3.73	33.6	57
S 20x65	3 6 9 12 13 14 16 19 28	65.0	19.08	20.00	0.500	6.250	0.790	16.814	1.593	3.96	33.6	57
S 20x64.8	19	64.8	19.04	20.00	0.500	6.250	0.765	16.912	1.544	4.08	33.8	56
S 20x64	1 2	64.0	18.80	20.00	0.500	6.250	0.765	16.912	1.544	4.08	33.8	56
S 18x90	2	90.0	26.47	18.00	0.807	7.245	0.927	14.381	1.809	3.91	17.8	-
S 18x90	21	90.0	26.46	18.00	0.820	7.080	0.885	14.385	1.808	4.00	17.5	-
S 18x90	5	90.0	26.29	18.00	0.796	7.236	0.927	14.381	1.809	3.90	18.1	-
S 18x85	2	85.0	25.00	18.00	0.725	7.163	0.927	14.381	1.809	3.86	19.8	-
S 18x85	21	85.0	25.00	18.00	0.740	7.000	0.885	14.385	1.808	3.95	19.4	-
S 18x85	5	85.0	24.81	18.00	0.714	7.154	0.927	14.381	1.809	3.86	20.1	-
S 18x80	2	80.0	23.53	18.00	0.644	7.082	0.927	14.381	1.809	3.82	22.3	-
S 18x80	21	80.0	23.53	18.00	0.790	6.660	0.765	14.651	1.674	4.35	18.5	-
S 18x80	19	80.0	23.50	18.00	0.700	6.630	0.915	14.241	1.880	3.62	20.3	-
S 18x80	5	80.0	23.34	18.00	0.632	7.072	0.927	14.381	1.809	3.81	22.8	-
S 18x75.6	5	75.6	22.04	18.00	0.560	7.000	0.927	14.381	1.809	3.78	25.7	-
S 18x75	2	75.0	22.05	18.00	0.562	7.000	0.927	14.381	1.809	3.78	25.6	-
S 18x75	21	75.0	22.05	18.00	0.710	6.580	0.765	14.651	1.674	4.30	20.6	-
S 18x75	19	75.0	22.10	18.00	0.620	6.550	0.915	14.241	1.880	3.58	23.0	-
S 18x75	26	75.0	21.93	18.00	0.792	6.332	0.691	15.095	1.453	4.58	19.1	-
S 18x70	29	70.0	20.60	18.00	0.650	6.370	0.770	14.782	1.609	4.14	22.7	-
S 18x70	21	70.0	20.59	18.00	0.620	6.500	0.765	14.651	1.674	4.25	23.6	-
S 18x70	1 9 12 14 15 18	70.0	20.59	18.00	0.719	6.259	0.691	15.095	1.453	4.53	21.0	-
S 18x70	23	70.0	20.59	18.00	0.705	6.245	0.691	15.095	1.453	4.52	21.4	-
S 18x70	8 11 17 26 13 27 28	70.0	20.46	18.00	0.711	6.251	0.691	15.095	1.453	4.52	21.2	-
S 18x70	16	70.0	20.42	18.00	0.709	6.249	0.691	15.095	1.453	4.52	21.3	-
S 18x67	20	67.0	19.70	18.00	0.560	6.500	0.775	14.731	1.634	4.19	26.3	-
S 18x65	1 9 12 14 15 18	65.0	19.12	18.00	0.637	6.177	0.691	15.095	1.453	4.47	23.7	-
S 18x65	21	65.0	19.12	18.00	0.630	6.170	0.690	15.099	1.451	4.47	24.0	-
S 18x65	23	65.0	19.12	18.00	0.623	6.163	0.691	15.095	1.453	4.46	24.2	-
S 18x65	19	65.0	19.10	18.00	0.640	6.170	0.705	15.059	1.471	4.38	23.5	-
S 18x65	6 10 17 26 13	65.0	18.98	18.00	0.629	6.169	0.691	15.095	1.453	4.46	24.0	-
S 18x65	16	65.0	18.92	18.00	0.626	6.166	0.691	15.095	1.453	4.46	24.1	-
S 18x60	1 9 12 14 15 18	60.0	17.65	18.00	0.550	6.095	0.691	15.095	1.453	4.41	27.4	-
S 18x60	23	60.0	17.65	18.00	0.542	6.082	0.691	15.095	1.453	4.40	27.8	-
S 18x60	21	60.0	17.64	18.00	0.540	6.080	0.690	15.099	1.451	4.41	28.0	-
S 18x60	19	60.0	17.60	18.00	0.550	6.080	0.705	15.059	1.471	4.31	27.4	-
S 18x60	6 10 17 26 13	60.0	17.50	18.00	0.547	6.087	0.691	15.095	1.453	4.40	27.6	-
S 18x60	16	60.0	17.43	18.00	0.543	6.083	0.691	15.095	1.453	4.40	27.8	-
S 18x55	19	55.0	16.20	18.00	0.470	6.000	0.705	15.059	1.471	4.26	32.0	63
S 18x55	20	55.0	16.20	18.00	0.460	6.000	0.690	15.099	1.451	4.35	32.8	60
S 18x55	22	55.0	16.18	18.00	0.460	6.000	0.691	15.095	1.453	4.34	32.8	60
S 18x55	21	55.0	16.13	18.00	0.460	6.000	0.690	15.099	1.451	4.35	32.8	60
S 18x55	1 9 12 15 16 18	55.0	15.93	18.00	0.460	6.000	0.691	15.095	1.453	4.34	32.8	60
S 18x54.7	25	54.7	16.09	18.00	0.460	6.000	0.691	15.095	1.453	4.34	32.8	60
S 18x54.7	8 11 13 14 17 24 27 28	54.7	15.94	18.00	0.460	6.000	0.691	15.095	1.453	4.34	32.8	60
S 18x48.2	4	48.2	14.09	18.00	0.380	7.500	0.502	15.979	1.011	7.47	42.0	36
S 18x48	3	48.0	14.08	18.00	0.380	7.500	0.502	15.979	1.011	7.47	42.0	36
S 18x46	2	46.0	13.53	18.00	0.322	6.000	0.664	15.239	1.381	4.52	47.3	29
S 18x46	7	46.0	13.34	18.00	0.380	6.000	0.555	15.780	1.110	5.41	41.5	37
S 15x100	2	100.0	29.50	15.00	1.170	6.810	1.035	11.211	1.894	3.29	9.6	-
S 15x100	19 20 22	100.0	29.46	15.00	1.192	6.792	1.033	10.821	2.089	3.29	9.1	-

Table 2.3.1 Dimensions and Primary Properties – Steel Sections 1887-1952

Designation	X ₁ ksi	X ₂ x 106 (1/ksi) ²	Elastic Properties						Plastic Modulus	
			Axis x-x			Axis y-y			Z _x in.3	Z _y in.3
			I _x in.4	S _x in.3	r _x in.	I _y in.4	S _y in.3	r _y in.		
S 20x80	3281	1817	1404.4	140.4	7.73	38.8	11.5	1.28	164.2	19.9
S 20x80	3352	1509	1470.3	147.0	7.90	42.3	12.5	1.34	171.1	21.4
S 20x80	3203	1867	1449.2	144.9	7.85	45.6	13.0	1.39	169.9	22.0
S 20x80	3400	1717	1345.1	134.5	7.55	33.2	10.4	1.19	160.5	18.1
S 20x78	3206	2000	1367.4	136.7	7.72	37.9	11.2	1.28	161.1	19.8
S 20x75	3243	2081	1278.6	127.9	7.57	30.5	9.5	1.17	153.4	16.9
S 20x75	3206	2222	1256.0	125.6	7.54	29.8	9.3	1.16	151.0	16.6
S 20x75	3308	1980	1246.9	124.7	7.53	28.2	9.2	1.13	150.9	16.2
S 20x75	3204	2166	1268.8	126.9	7.58	30.3	9.5	1.17	152.0	16.8
S 20x75	3154	2275	1277.1	127.8	7.61	30.1	9.4	1.17	151.2	16.7
S 20x75	3175	2248	1268.8	126.9	7.58	30.2	9.5	1.17	151.1	16.7
S 20x75	3182	2217	1263.5	126.3	7.60	30.1	9.4	1.17	151.2	16.7
S 20x70	3026	2593	1229.3	122.9	7.68	29.3	9.2	1.18	146.0	16.1
S 20x70	2977	2816	1206.0	120.6	7.65	28.5	9.0	1.18	143.5	15.8
S 20x70	3036	2625	1197.6	119.8	7.68	26.7	8.8	1.15	141.9	15.2
S 20x70	2989	2695	1219.8	122.0	7.70	29.0	9.2	1.19	144.6	16.0
S 20x70	2975	2748	1219.7	122.0	7.70	29.0	9.2	1.19	144.1	15.9
S 20x70	2927	2892	1229.0	122.9	7.73	28.9	9.2	1.18	143.2	15.8
S 20x70	2949	2806	1229.0	122.9	7.73	28.9	9.2	1.18	143.4	15.7
S 20x70	2969	2753	1214.2	121.4	7.71	28.9	9.2	1.19	143.8	15.9
S 20x66.67	2838	3263	1172.7	117.3	7.73	27.9	8.9	1.19	138.5	15.3
S 20x65.4	2796	3316	1174.6	117.5	7.81	28.0	9.0	1.21	137.1	15.3
S 20x65.4	2799	3282	1169.5	116.9	7.83	27.9	8.9	1.21	137.1	15.3
S 20x65	2777	3335	1179.7	118.0	7.86	27.7	8.9	1.20	137.2	15.3
S 20x65	2854	3142	1148.6	114.9	7.76	25.5	8.5	1.16	134.9	14.6
S 20x65	2796	3288	1169.5	117.0	7.83	27.9	8.9	1.21	137.1	15.3
S 20x64.8	2753	3639	1145.8	114.6	7.76	26.7	8.5	1.18	134.5	14.9
S 20x64	2736	3639	1146.0	114.6	7.80	27.3	8.7	1.20	134.5	14.9
S 18x90	4245	657	1260.4	140.0	6.90	52.0	14.4	1.40	167.1	25.1
S 18x90	4388	650	1188.0	132.0	6.70	46.0	13.0	1.32	161.1	23.1
S 18x90	4206	677	1256.5	139.6	6.91	51.9	14.3	1.40	166.2	25.0
S 18x85	3992	799	1220.7	135.6	6.99	50.0	14.0	1.42	160.5	24.1
S 18x85	4118	800	1149.6	127.7	6.78	44.2	12.6	1.33	154.6	22.1
S 18x85	3955	821	1216.6	135.2	7.00	49.8	14.0	1.42	159.6	23.9
S 18x80	3767	954	1181.0	131.2	7.09	48.1	13.6	1.43	153.9	23.1
S 18x80	4015	928	1063.4	118.2	6.72	33.1	10.0	1.19	141.3	18.1
S 18x80	3990	824	1131.2	125.7	6.94	39.5	11.9	1.30	149.3	20.5
S 18x80	3731	981	1176.8	130.8	7.10	47.9	13.6	1.43	153.0	22.9
S 18x75.6	3555	1127	1141.8	126.9	7.20	46.3	13.2	1.45	147.1	22.1
S 18x75	3563	1120	1141.3	126.8	7.19	46.2	13.2	1.45	147.3	22.1
S 18x75	3720	1194	1023.5	113.7	6.81	31.7	9.6	1.20	134.8	17.2
S 18x75	3766	986	1091.6	121.3	7.04	37.4	11.4	1.30	142.8	19.6
S 18x75	3958	1064	957.2	106.3	6.61	25.6	8.1	1.08	130.3	15.3
S 18x70	3514	1448	973.1	108.1	6.87	28.8	9.0	1.18	128.4	16.0
S 18x70	3426	1573	981.7	109.1	6.91	30.2	9.3	1.21	127.6	16.3
S 18x70	3650	1397	921.3	102.4	6.69	24.6	7.9	1.09	124.4	14.5
S 18x70	3590	1493	921.3	102.4	6.69	24.6	7.9	1.09	123.3	14.4
S 18x70	3622	1437	917.5	101.9	6.70	24.5	7.8	1.09	123.8	14.4
S 18x70	3614	1448	916.5	101.8	6.70	24.3	7.8	1.10	123.6	14.4
S 18x67	3210	1897	973.5	108.2	7.03	30.3	9.3	1.24	124.5	16.2
S 18x65	3340	1880	881.5	97.9	6.79	23.5	7.6	1.11	117.8	13.7
S 18x65	3276	1991	889.7	98.9	6.82	23.3	7.6	1.10	117.1	13.6
S 18x65	3286	2006	881.5	97.9	6.79	23.5	7.6	1.11	116.6	13.6
S 18x65	3377	1771	886.1	98.5	6.81	23.9	7.7	1.12	119.2	13.9
S 18x65	3311	1935	877.7	97.5	6.80	23.4	7.6	1.11	117.1	13.6
S 18x65	3297	1958	876.2	97.4	6.81	23.3	7.6	1.11	116.9	13.6
S 18x60	3044	2548	841.8	93.5	6.91	22.4	7.3	1.13	110.8	12.9
S 18x60	3016	2643	841.8	93.5	6.91	22.4	7.4	1.13	110.1	12.8
S 18x60	2976	2733	849.9	94.4	6.94	22.2	7.3	1.12	109.8	12.8
S 18x60	3069	2415	846.5	94.1	6.94	22.7	7.5	1.13	111.9	13.1
S 18x60	3033	2563	837.8	93.1	6.92	22.3	7.3	1.13	110.5	12.9
S 18x60	3020	2598	835.9	92.9	6.93	22.2	7.3	1.13	110.1	12.8
S 18x55	2845	3055	806.8	89.6	7.08	21.6	7.2	1.16	105.4	12.4
S 18x55	2751	3481	809.0	89.9	7.07	20.8	6.9	1.13	103.3	12.1
S 18x55	2800	3345	795.6	88.4	7.07	21.2	7.1	1.15	103.4	12.1
S 18x55	2745	3481	809.1	89.9	7.08	21.2	7.1	1.14	103.3	12.1
S 18x55	2778	3345	795.6	88.4	7.07	21.2	7.1	1.15	103.4	12.1
S 18x54.7	2776	3383	789.8	88.9	7.05	21.4	7.1	1.15	103.4	12.1
S 18x54.7	2779	3345	795.6	88.4	7.07	21.2	7.1	1.15	103.4	12.1
S 18x48.2	1959	12602	737.1	81.9	7.23	30.0	8.0	1.46	93.3	13.4
S 18x48	1958	12602	737.1	81.9	7.23	30.0	8.0	1.46	93.3	13.4
S 18x46	2353	5531	733.2	81.5	7.36	19.9	6.6	1.21	91.3	11.1
S 18x46	2143	9327	675.1	75.1	7.12	17.1	5.7	1.13	85.1	9.7
S 15x100	6942	104	898.4	119.8	5.52	52.0	15.3	1.33	147.3	27.4
S 15x100	7200	90	899.4	119.9	5.53	50.9	15.0	1.31	147.7	27.2

Table 2.3.1 Dimensions and Primary Properties -- Steel Sections 1887-1952

Designation	Source Reference Number	Wt. per ft lb	Area	Depth	Web Thickness	Flange Width	Average Flange Thickness	Distance	Distance	Compact Section Criteria		
			A	d	t _w	b _f	t _f	T	k	b _f /2t _f	h/t _w	F _y "
			in.2	in.	in.	in.	in.	in.	in.	in.		
S 15x100	30	100.0	29.41	15.00	1.192	6.792	1.034	10.836	2.082	3.29	9.1	-
S 15x100	15	100.0	29.41	15.00	1.190	6.790	1.035	10.830	2.085	3.28	9.1	-
S 15x100	4 10 12 13	100.0	29.41	15.00	1.184	6.774	1.043	10.801	2.099	3.25	9.1	-
S 15x100	33 34	100.0	29.41	15.00	1.170	6.770	1.034	10.836	2.082	3.28	9.3	-
S 15x100	8 16	100.0	29.08	15.00	1.167	6.767	1.034	10.836	2.082	3.27	9.3	-
S 15x95	3	95.0	28.00	15.00	1.070	6.710	1.035	11.211	1.894	3.24	10.5	-
S 15x95	19 20 22	95.0	27.98	15.00	1.094	6.694	1.033	10.821	2.089	3.24	9.9	-
S 15x95	30	95.0	27.94	15.00	1.094	6.694	1.034	10.836	2.082	3.24	9.9	-
S 15x95	15	95.0	27.94	15.00	1.090	6.690	1.035	10.830	2.085	3.23	9.9	-
S 15x95	4 10 12 23	95.0	27.94	15.00	1.085	6.675	1.043	10.801	2.099	3.20	10.0	-
S 15x95	33 34	95.0	27.94	15.00	1.070	6.670	1.034	10.836	2.082	3.23	10.1	-
S 15x95	8 16	95.0	27.59	15.00	1.068	6.668	1.034	10.836	2.082	3.23	10.1	-
S 15x90	19 20 22	90.0	26.51	15.00	0.966	6.596	1.035	10.830	2.085	3.19	11.2	-
S 15x90	3	90.0	26.50	15.00	0.970	6.610	1.035	11.211	1.894	3.19	11.6	-
S 15x90	30	90.0	26.47	15.00	0.996	6.596	1.034	10.836	2.082	3.19	10.9	-
S 15x90	15	90.0	26.47	15.00	0.990	6.590	1.035	10.830	2.085	3.18	10.9	-
S 15x90	4 10 12 23	90.0	26.47	15.00	0.987	6.577	1.043	10.801	2.099	3.15	10.9	-
S 15x90	33 34	90.0	26.47	15.00	0.970	6.570	1.034	10.836	2.082	3.18	11.2	-
S 15x90	8 16	90.0	26.12	15.00	0.970	6.570	1.034	10.836	2.082	3.18	11.2	-
S 15x85.1	27	85.1	25.03	15.00	0.910	6.710	0.925	11.090	1.955	3.63	12.2	-
S 15x85	3	85.0	25.00	15.00	0.870	6.510	1.035	11.211	1.894	3.14	12.9	-
S 15x85	15	85.0	25.00	15.00	0.900	6.500	1.035	10.830	2.085	3.14	12.0	-
S 15x85	30	85.0	25.00	15.00	0.898	6.498	1.034	10.836	2.082	3.14	12.1	-
S 15x85	19 20 22	85.0	25.04	15.00	0.898	6.498	1.033	10.838	2.081	3.15	12.1	-
S 15x85	4 10 12 13	85.0	25.00	15.00	0.889	6.479	1.043	10.801	2.099	3.11	12.2	-
S 15x85	33 34	85.0	25.00	15.00	0.870	6.470	1.034	10.836	2.082	3.13	12.5	-
S 15x85	8 16	85.0	24.65	15.00	0.872	6.472	1.034	10.836	2.082	3.13	12.4	-
S 15x81.3	32 33	81.3	23.91	15.00	0.800	6.400	1.034	10.836	2.082	3.10	13.5	-
S 15x81.3	10	81.3	23.81	15.00	0.800	6.400	1.035	10.830	2.085	3.09	13.5	-
S 15x81.3	8 16 22	81.3	23.57	15.00	0.800	6.400	1.034	10.836	2.082	3.10	13.5	-
S 15x80	4 12 23	80.0	23.81	15.00	0.810	6.400	1.043	10.801	2.099	3.07	13.3	-
S 15x80	18	80.0	23.60	15.00	0.840	6.465	1.001	11.245	1.878	3.23	13.4	-
S 15x80	15 19	80.0	23.57	15.00	0.800	6.400	1.035	10.830	2.085	3.09	13.5	-
S 15x80	19 20	80.0	23.56	15.00	0.982	6.392	0.815	11.641	1.679	3.92	11.9	-
S 15x80	28	80.0	23.54	15.00	0.830	6.630	0.930	11.314	1.843	3.56	13.6	-
S 15x80	30	80.0	23.53	15.00	0.800	6.400	1.034	10.836	2.082	3.10	13.5	-
S 15x80	15	80.0	23.53	15.00	0.980	6.390	0.815	11.641	1.679	3.92	11.9	-
S 15x80	2 3	80.0	23.50	15.00	0.770	6.410	1.035	11.211	1.894	3.10	14.6	-
S 15x80	26	80.0	23.50	15.00	0.910	6.390	0.900	11.618	1.691	3.55	12.8	-
S 15x75	3	75.0	22.10	15.00	0.840	6.340	0.900	11.698	1.651	3.52	13.9	-
S 15x75	1	75.0	22.10	15.00	0.670	6.310	1.035	11.211	1.894	3.05	16.7	-
S 15x75	25 26	75.0	22.10	15.00	0.810	6.290	0.900	11.618	1.691	3.49	14.3	-
S 15x75	19 20	75.0	22.08	15.00	0.884	6.292	0.815	11.641	1.679	3.86	13.2	-
S 15x75	4 12 15 17 21 23 30	75.0	22.06	15.00	0.882	6.292	0.816	11.639	1.680	3.86	13.2	-
S 15x75	28	75.0	22.05	15.00	0.730	6.530	0.930	11.314	1.843	3.51	15.5	-
S 15x75	29	75.0	22.05	15.00	0.620	6.375	1.060	11.298	1.851	3.01	18.2	-
S 15x75	7 10 13 16 22 34	75.0	21.85	15.00	0.868	6.278	0.816	11.639	1.680	3.85	13.4	-
S 15x70.4	27	70.4	20.70	15.00	0.760	6.360	0.805	11.685	1.658	3.95	15.4	-
S 15x70	19 20	70.0	20.61	15.00	0.786	6.196	0.815	11.641	1.679	3.80	14.8	-
S 15x70	28	70.0	20.60	15.00	0.630	6.430	0.930	11.314	1.843	3.46	18.0	-
S 15x70	18	70.0	20.60	15.00	0.640	6.265	1.001	11.245	1.878	3.13	17.6	-
S 15x70	3	70.0	20.60	15.00	0.740	6.240	0.900	11.698	1.651	3.47	15.8	-
S 15x70	26	70.0	20.60	15.00	0.720	6.200	0.900	11.618	1.691	3.44	16.1	-
S 15x70	4 12 15 17 21 23 30	70.0	20.59	15.00	0.784	6.194	0.816	11.639	1.680	3.80	14.8	-
S 15x70	7 10 13 16 22 34	70.0	20.38	15.00	0.770	6.180	0.816	11.639	1.680	3.79	15.1	-
S 15x69.2	27	69.2	20.38	15.00	0.600	6.400	0.925	11.425	1.788	3.46	19.0	-
S 15x69.2	18	69.2	20.36	15.00	0.671	6.171	0.938	11.371	1.815	3.29	16.9	-
S 15x66.67	25	66.67	19.70	15.00	0.650	6.130	0.900	11.618	1.691	3.41	17.9	-
S 15x66.67	3	66.67	19.60	15.00	0.670	6.170	0.900	11.698	1.651	3.43	17.5	-
S 15x65	19 20	65.0	19.14	15.00	0.688	6.098	0.815	11.641	1.679	3.74	16.9	-
S 15x65	4 12 15 17 21 23 30	65.0	19.12	15.00	0.686	6.096	0.816	11.639	1.680	3.74	17.0	-
S 15x65	28	65.0	19.11	15.00	0.650	6.270	0.805	11.708	1.646	3.89	18.0	-
S 15x65	26	65.0	19.10	15.00	0.620	6.100	0.900	11.618	1.691	3.39	18.7	-
S 15x65	7 10 13 16 22 34	65.0	18.91	15.00	0.672	6.082	0.816	11.639	1.680	3.73	17.3	-
S 15x60.8	33	60.8	17.88	15.00	0.590	6.000	0.816	11.639	1.680	3.68	19.7	-
S 15x60.8	7 10 13 16 22 30 32 34	60.8	17.68	15.00	0.590	6.000	0.816	11.639	1.680	3.68	19.7	-
S 15x60	4 12 15 17 19 20 21 23	60.0	17.67	15.00	0.590	6.000	0.816	11.639	1.680	3.68	19.7	-
S 15x60	15	60.0	17.65	15.00	0.750	5.840	0.620	12.362	1.319	4.71	16.5	-
S 15x60	28	60.0	17.64	15.00	0.550	6.170	0.805	11.708	1.646	3.83	21.3	-
S 15x60	29	60.0	17.64	15.00	0.500	6.125	0.860	11.718	1.641	3.56	23.4	-
S 15x60	1 2 3	60.0	17.60	15.00	0.540	6.040	0.900	11.698	1.651	3.36	21.7	-
S 15x60	25 26	60.0	17.60	15.00	0.520	6.000	0.900	11.618	1.691	3.33	22.3	-
S 15x59	18	59.0	17.30	15.00	0.468	5.968	0.938	11.371	1.815	3.18	24.3	-
S 15x57.6	27	57.6	16.95	15.00	0.500	6.100	0.805	11.685	1.658	3.79	23.4	-
S 15x56.9	27	56.9	16.74	15.00	0.600	5.950	0.695	11.925	1.538	4.28	19.9	-
S 15x56.5	18	56.5	16.70	15.00	0.572	5.892	0.703	12.143	1.428	4.19	21.2	-

Table 2.3.1 Dimensions and Primary Properties – Steel Sections 1887-1952

Designation	X ₁ ksi	X ₂ x 106 (1/ksi) ²	Elastic Properties						Plastic Modulus	
			Axis x-x			Axis y-y			Z _x in.3	Z _y in.3
			I _x in.4	S _x in.3	r _x in.	I _y in.4	S _y in.3	r _y in.		
S 15x100	7176	90	900.5	120.1	5.53	51.0	15.0	1.31	147.8	27.2
S 15x100	7189	90	898.6	119.8	5.53	50.8	15.0	1.31	147.8	27.2
S 15x100	7177	90	900.5	120.1	5.53	51.0	15.1	1.31	147.9	27.2
S 15x100	7079	96	898.6	119.8	5.53	50.3	14.9	1.31	146.5	26.9
S 15x100	7071	95	892.4	119.0	5.54	50.2	14.8	1.31	146.4	26.8
S 15x95	6485	132	870.3	116.0	5.58	49.4	14.7	1.33	141.6	26.0
S 15x95	6740	112	871.7	116.2	5.58	48.3	14.4	1.31	142.2	25.8
S 15x95	6718	113	872.9	116.4	5.59	48.4	14.5	1.32	142.3	25.8
S 15x95	6722	113	871.0	116.1	5.58	48.3	14.4	1.31	142.2	25.8
S 15x95	6718	113	872.9	116.4	5.59	48.4	14.5	1.32	142.3	25.8
S 15x95	6618	121	871.1	116.1	5.58	47.7	14.3	1.31	140.9	25.5
S 15x95	6613	120	864.5	115.3	5.60	47.7	14.3	1.31	140.8	25.4
S 15x90	6185	152	844.1	112.5	5.64	45.8	13.9	1.32	135.6	24.3
S 15x90	6055	166	842.2	112.3	5.64	46.9	14.2	1.33	136.0	24.6
S 15x90	6288	141	845.4	112.7	5.64	45.9	13.9	1.32	136.8	24.5
S 15x90	6279	142	843.4	112.5	5.64	45.8	13.9	1.32	136.5	24.4
S 15x90	6293	140	845.4	112.7	5.65	45.9	14.0	1.32	136.8	24.5
S 15x90	6182	151	843.5	112.5	5.65	45.3	13.8	1.31	135.3	24.1
S 15x90	6191	149	837.0	111.6	5.66	45.2	13.8	1.32	135.3	24.1
S 15x85.1	5719	215	789.2	105.2	5.61	42.6	12.7	1.30	126.6	22.3
S 15x85	5664	206	814.0	108.5	5.71	44.6	13.7	1.34	130.4	23.3
S 15x85	5916	172	815.9	108.8	5.71	43.5	13.4	1.32	131.5	23.3
S 15x85	5890	175	817.8	109.0	5.72	43.6	13.4	1.32	131.2	23.2
S 15x85	5898	175	816.5	108.9	5.71	43.5	13.4	1.32	131.2	23.2
S 15x85	5900	173	817.8	109.0	5.72	43.6	13.4	1.32	131.3	23.2
S 15x85	5786	188	815.9	108.8	5.71	43.0	13.3	1.31	129.7	22.9
S 15x85	5801	184	809.4	107.9	5.73	42.9	13.3	1.32	129.8	22.9
S 15x81.3	5528	217	795.5	106.1	5.78	41.8	12.9	1.32	125.7	22.0
S 15x81.3	5524	216	795.5	106.1	5.78	41.8	13.1	1.32	125.8	22.0
S 15x81.3	5536	214	789.1	105.2	5.79	41.3	12.9	1.32	125.7	22.0
S 15x80	5603	204	795.5	106.1	5.78	41.8	13.1	1.32	126.8	22.3
S 15x80	5424	234	787.4	105.0	5.78	42.1	13.0	1.34	126.0	22.2
S 15x80	5543	212	789.1	105.2	5.79	41.3	12.9	1.32	125.8	22.0
S 15x80	5776	223	719.3	95.9	5.53	32.5	10.2	1.18	117.7	18.8
S 15x80	5229	282	773.8	103.2	5.73	40.7	12.3	1.32	122.5	21.4
S 15x80	5484	217	795.5	106.1	5.78	41.8	13.1	1.32	125.7	22.0
S 15x80	5767	225	718.8	95.8	5.53	32.5	10.2	1.17	117.6	18.8
S 15x80	5306	253	785.9	104.8	5.82	42.2	13.2	1.35	124.8	22.1
S 15x80	5467	253	747.8	99.7	5.64	37.0	11.6	1.25	120.6	20.1
S 15x75	5098	312	728.4	97.1	5.74	35.8	11.3	1.27	117.0	19.6
S 15x75	5003	305	757.7	101.0	5.86	40.1	12.7	1.35	119.1	21.0
S 15x75	5057	330	720.4	96.0	5.72	34.6	11.0	1.25	115.0	18.9
S 15x75	5301	299	691.8	92.2	5.60	30.7	9.8	1.18	112.2	17.6
S 15x75	5291	301	691.2	92.2	5.60	30.7	9.8	1.18	112.1	17.6
S 15x75	4863	356	746.0	99.5	5.82	38.6	11.8	1.32	116.8	20.2
S 15x75	4964	313	757.7	101.0	5.86	40.1	12.6	1.35	119.8	21.6
S 15x75	5231	313	687.2	91.6	5.61	30.6	9.8	1.18	111.3	17.5
S 15x70.4	4819	431	654.1	87.2	5.62	30.9	9.7	1.22	106.7	17.1
S 15x70	4861	400	664.2	88.6	5.68	29.0	9.4	1.19	106.7	16.6
S 15x70	4543	440	718.7	95.8	5.91	36.7	11.4	1.33	111.2	19.2
S 15x70	4755	351	731.1	97.5	5.95	37.8	12.1	1.35	114.7	20.0
S 15x70	4707	404	700.3	93.4	5.83	33.9	10.9	1.28	111.4	18.5
S 15x70	4710	411	692.8	92.4	5.80	32.5	10.5	1.26	110.0	18.0
S 15x70	4857	401	663.6	88.5	5.68	29.0	9.4	1.19	106.6	16.6
S 15x70	4802	417	659.6	87.9	5.69	28.8	9.3	1.19	105.8	16.5
S 15x69.2	4420	493	710.0	94.7	5.90	36.2	11.3	1.33	109.2	18.9
S 15x69.2	4711	393	698.3	93.1	5.86	33.8	11.0	1.29	110.2	18.4
S 15x66.67	4471	487	676.3	90.1	5.87	31.7	10.3	1.27	106.0	17.3
S 15x66.67	4461	478	681.4	90.9	5.90	32.7	10.6	1.29	107.4	17.8
S 15x65	4467	526	636.6	84.9	5.77	27.4	9.0	1.20	101.2	15.6
S 15x65	4465	527	636.0	84.8	5.77	27.4	9.0	1.20	101.1	15.6
S 15x65	4238	629	646.6	86.2	5.82	29.1	9.3	1.23	100.7	16.0
S 15x65	4371	517	665.3	88.7	5.90	30.7	10.1	1.27	104.3	17.0
S 15x65	4411	548	632.1	84.3	5.78	27.2	8.9	1.20	100.3	15.5
S 15x60.8	4122	684	612.9	81.7	5.86	26.0	8.7	1.21	95.7	14.7
S 15x60.8	4124	675	609.0	81.2	5.87	26.0	8.7	1.21	95.7	14.7
S 15x60	4123	675	609.0	81.2	5.87	26.0	8.7	1.21	95.7	14.7
S 15x60	4381	695	538.6	71.8	5.52	18.2	6.2	1.01	87.5	11.6
S 15x60	3911	807	619.0	82.5	5.92	27.6	8.9	1.25	95.1	15.1
S 15x60	3827	805	644.0	85.9	6.04	30.4	9.9	1.32	96.5	15.9
S 15x60	4064	626	644.0	85.9	6.04	30.4	10.1	1.32	100.1	16.5
S 15x60	4079	631	637.7	85.0	6.02	29.2	9.7	1.29	98.7	16.0
S 15x59	4142	566	640.9	85.3	6.08	30.3	10.2	1.32	98.8	16.5
S 15x57.6	3908	838	583.8	77.8	5.87	27.0	8.8	1.26	92.0	14.7
S 15x56.9	3822	984	560.8	74.8	5.79	21.5	7.2	1.13	86.9	12.6
S 15x56.5	3766	1104	543.7	72.5	5.71	21.1	7.2	1.12	85.6	12.4

Table 2.3.1 Dimensions and Primary Properties -- Steel Sections 1887-1952

Designation	X ₁ ksi	X ₂ x 106 (1/ksi) ²	Elastic Properties						Plastic Modulus	
			Axis x-x			Axis y-y			Z _x	Z _y
			I _x in.4	S _x in.3	r _x in.	I _y in.4	S _y in.3	r _y in.	in.3	in.3
S 15x55	3734	1014	557.8	74.4	5.87	22.2	7.6	1.17	87.5	12.9
S 15x55	3744	1006	557.3	74.3	5.87	22.2	7.6	1.17	87.5	12.9
S 15x55	3977	956	511.0	68.1	5.62	17.1	5.9	1.02	82.9	10.9
S 15x55	3972	960	511.0	68.1	5.62	17.1	5.9	1.00	82.8	10.9
S 15x55	3932	1000	511.0	68.1	5.62	17.1	5.9	1.02	82.3	10.8
S 15x55	3679	1144	542.8	72.4	5.79	20.3	6.9	1.12	84.5	12.0
S 15x55	3895	1032	508.7	67.8	5.63	17.0	5.9	1.03	81.9	10.8
S 15x52.9	3649	1317	497.7	66.4	5.65	17.1	5.9	1.05	78.5	10.4
S 15x50	3513	1439	489.2	65.2	5.74	16.1	5.7	1.04	77.3	10.1
S 15x50	3540	1402	483.4	64.5	5.73	16.0	5.7	1.04	77.3	10.1
S 15x50	3501	1465	483.4	64.5	5.73	16.0	5.7	1.04	76.8	10.1
S 15x50	3333	1558	515.2	68.7	5.92	19.2	6.6	1.14	78.9	11.3
S 15x50	3433	1299	529.7	70.6	6.00	21.0	7.3	1.20	81.9	12.1
S 15x50	3469	1510	481.1	64.2	5.74	16.0	5.7	1.05	76.4	10.0
S 15x49.3	3255	1640	518.6	69.2	5.98	19.7	6.8	1.17	78.4	11.4
S 15x48	3242	1724	459.9	66.1	5.93	19.2	6.7	1.16	76.2	11.1
S 15x47.5	3363	1838	451.1	60.1	5.66	14.5	5.1	1.01	71.8	9.16
S 15x45	3146	2042	461.6	61.5	5.88	15.2	5.5	1.07	71.8	9.45
S 15x45	3170	1987	455.8	60.8	5.87	15.0	5.4	1.06	71.8	9.45
S 15x45	3138	2070	455.9	60.8	5.87	15.1	5.4	1.07	71.3	9.39
S 15x45	3061	2239	460.3	61.4	5.90	15.0	5.4	1.06	70.6	9.30
S 15x45	3140	2152	446.6	59.5	5.82	14.7	5.3	1.06	70.3	9.16
S 15x45	3037	2459	446.1	59.5	5.88	14.5	5.2	1.06	69.2	9.03
S 15x45	3111	2125	453.6	60.5	5.88	15.0	5.4	1.07	70.9	9.34
S 15x42.9	2979	2442	444.3	59.2	5.93	14.6	5.3	1.08	68.5	9.07
S 15x42.9	2979	2417	441.8	58.9	5.95	14.6	5.3	1.08	68.5	9.07
S 15x42.4	2967	2454	441.8	58.9	5.95	14.6	5.3	1.08	68.4	9.05
S 15x42	2978	2417	441.8	58.9	5.95	14.6	5.3	1.08	68.5	9.07
S 15x42	2849	3025	429.6	57.3	5.90	14.0	5.1	1.08	65.8	8.65
S 15x42	2937	2479	443.7	59.2	5.99	14.4	5.2	1.08	68.4	9.05
S 15x41.2	2820	2956	433.0	57.7	5.98	14.9	5.3	1.11	65.6	8.89
S 15x41	2874	2835	424.1	56.5	5.94	14.0	5.1	1.08	65.8	8.65
S 15x41	2863	2845	424.1	56.6	5.94	14.0	5.1	1.08	65.8	8.65
S 15x39	2739	3466	403.3	53.8	5.92	13.1	4.8	1.06	62.5	8.11
S 15x37.5	2081	9400	405.5	54.1	6.10	19.9	5.9	1.35	61.2	9.77
S 15x37.3	2081	9400	405.5	54.1	6.10	19.9	5.9	1.35	61.2	9.77
S 15x36	2519	4096	405.1	54.0	6.17	13.5	4.9	1.13	60.3	8.20
S 15x36	2434	5303	381.5	50.9	6.00	12.0	4.3	1.07	57.8	7.42
S 15x36	2514	4096	405.1	54.0	6.17	13.5	4.9	1.13	60.3	8.20
S 15x36	2542	4005	400.9	53.4	6.15	13.5	4.9	1.13	60.3	8.20
S 15x35	2241	7432	367.9	49.0	6.00	11.6	4.2	1.06	55.3	7.08
S 15x33	2274	6394	365.0	48.7	6.13	11.6	4.2	1.09	54.4	7.12
S 12x66.9	6671	109	403.4	67.2	4.53	29.7	9.9	1.23	82.1	17.29
S 12x65	6245	134	403.5	67.3	4.59	28.9	9.7	1.23	79.8	16.55
S 12x65	6288	139	393.3	65.6	4.55	28.8	9.2	1.23	79.4	16.41
S 12x60	6009	200	338.0	56.3	4.37	21.0	7.0	1.09	68.6	12.81
S 12x60	5730	177	385.8	64.3	4.68	27.0	9.2	1.24	75.5	15.46
S 12x60	6677	129	339.5	56.6	4.39	18.9	6.6	1.03	69.9	12.50
S 12x60	5637	201	375.7	62.6	4.63	26.9	8.8	1.24	74.7	15.22
S 12x56.7	5685	215	341.8	57.0	4.52	21.5	7.3	1.13	69.0	13.01
S 12x56.67	5676	217	341.4	56.9	4.52	21.4	7.2	1.13	68.9	12.98
S 12x55.5	5387	218	362.9	60.5	4.71	25.3	8.8	1.24	71.7	14.72
S 12x55	5928	196	321.9	53.6	4.45	17.5	6.2	1.04	65.6	11.48
S 12x55	5924	196	321.0	53.5	4.45	17.5	6.2	1.04	65.6	11.48
S 12x55	5884	201	321.0	53.5	4.45	17.5	6.2	1.04	65.4	11.43
S 12x55	5291	225	368.1	61.3	4.77	25.1	8.7	1.25	71.1	14.47
S 12x55	5112	274	358.1	59.7	4.72	25.2	8.4	1.25	70.4	14.21
S 12x55	5813	210	319.3	53.2	4.46	17.3	6.2	1.04	64.9	11.33
S 12x50	5215	303	304.4	50.7	4.54	16.2	5.9	1.05	61.2	10.53
S 12x50	5202	304	303.3	50.6	4.54	16.1	5.9	1.05	61.1	10.52
S 12x50	5168	312	303.3	50.6	4.54	16.1	5.9	1.05	60.9	10.48
S 12x50	4810	378	317.3	52.9	4.65	19.4	6.7	1.15	62.9	11.67
S 12x50	4819	376	316.5	52.8	4.65	19.4	6.8	1.15	62.9	11.67
S 12x50	4659	478	302.0	50.3	4.53	18.1	6.3	1.11	59.6	10.89
S 12x50	4754	356	332.1	55.4	4.75	20.8	7.3	1.19	64.1	12.29
S 12x50	5105	325	301.6	50.3	4.55	16.0	5.8	1.05	60.5	10.39
S 12x48	4564	486	301.4	50.2	4.61	18.0	6.3	1.13	59.5	10.85
S 12x47.6	4716	417	299.8	50.0	4.63	16.5	6.1	1.09	58.9	10.35
S 12x45	4586	462	286.7	47.8	4.64	15.0	5.6	1.06	56.8	9.67
S 12x45	4588	460	285.7	47.6	4.65	14.9	5.5	1.06	56.7	9.66
S 12x45	4554	474	285.7	47.6	4.65	14.9	5.6	1.06	56.5	9.62
S 12x45	4382	525	292.3	48.7	4.70	15.4	5.7	1.08	56.6	9.80
S 12x45	4279	547	299.3	49.9	4.76	18.1	6.4	1.17	58.4	10.79
S 12x45	4268	555	298.9	49.8	4.76	18.0	6.4	1.17	58.2	10.76
S 12x45	4506	490	284.1	47.3	4.66	14.8	5.5	1.06	56.1	9.55

Table 2.3.1 Dimensions and Primary Properties -- Steel Sections 1887-1952

Designation	Source Reference Number	Wt. per ft lb	Area	Depth	Web Thickness	Flange Width	Average Flange Thickness	Distance T	Distance k	Compact Section Criteria		
			A in.2	d in.	t_w in.	b_f in.	t_f in.			$b_f/2t_f$	h/t_w	F_y " ksi
S 12x44.1	25	44.1	13.04	12.00	0.680	5.340	0.508	9.695	1.153	5.26	14.3	-
S 12x40.8	32	40.8	12.00	12.00	0.460	5.250	0.660	9.221	1.390	3.98	20.0	-
S 12x40.8	35	40.8	11.84	12.00	0.460	5.250	0.660	9.221	1.390	3.98	20.0	-
S 12x40	4 10 13 17 19 21	40.0	11.84	12.00	0.460	5.250	0.660	9.221	1.390	3.98	20.0	-
S 12x40	23 24	40.0	11.80	12.00	0.390	5.500	0.690	9.279	1.361	3.99	23.8	-
S 12x40	27	40.0	11.77	12.00	0.420	5.250	0.680	9.246	1.377	3.86	22.0	-
S 12x40	28	40.0	11.76	12.00	0.460	5.250	0.660	9.221	1.390	3.98	20.0	-
S 12x40	13 15	40.0	11.76	12.00	0.558	5.215	0.544	9.647	1.177	4.79	17.3	-
S 12x40	22	40.0	11.73	12.00	0.390	5.500	0.705	9.219	1.391	3.90	23.6	-
S 12x40	1 2 3 28	40.0	11.70	12.00	0.390	5.500	0.690	9.279	1.361	3.99	23.8	-
S 12x39.4	26	39.4	11.60	12.00	0.400	5.250	0.680	9.319	1.341	3.86	23.3	-
S 12x39	2	39.0	11.50	12.00	0.525	5.425	0.535	9.599	1.201	5.07	18.3	-
S 12x39	25	39.0	11.52	12.00	0.553	5.213	0.508	9.695	1.153	5.13	17.5	-
S 12x38.4	26	38.4	11.29	12.00	0.530	5.190	0.505	9.679	1.161	5.14	18.3	-
S 12x38	16	38.0	11.20	12.00	0.343	5.468	0.657	9.351	1.325	4.16	27.3	-
S 12x37.5	16	37.5	11.40	12.00	0.508	5.414	0.516	9.633	1.184	5.25	19.0	-
S 12x36.6	25	36.6	10.80	12.00	0.493	5.153	0.508	9.695	1.153	5.07	19.7	-
S 12x36	3	36.0	10.60	12.00	0.450	5.350	0.535	9.599	1.201	5.00	21.3	-
S 12x35	24	35.0	10.30	12.00	0.440	5.220	0.525	9.619	1.191	4.97	21.9	-
S 12x35	4 10 13 19 21 28	35.0	10.29	12.00	0.436	5.086	0.544	9.647	1.177	4.67	22.1	-
S 12x35	17	35.0	10.29	12.00	0.436	5.085	0.545	9.645	1.178	4.67	22.1	-
S 12x35	27	35.0	10.29	12.00	0.420	5.070	0.545	9.643	1.179	4.65	23.0	-
S 12x35	7 9 11 12 14 20 33 34	35.0	10.20	12.00	0.428	5.078	0.544	9.647	1.177	4.67	22.5	-
S 12x34.1	25	34.1	10.04	12.00	0.430	5.090	0.508	9.695	1.153	5.01	22.5	-
S 12x32	22	32.0	9.46	12.00	0.320	5.250	0.580	9.479	1.261	4.53	29.6	-
S 12x32	1 2 3 28	32.0	9.40	12.00	0.350	5.250	0.535	9.599	1.201	4.91	27.4	-
S 12x31.8	32	31.8	9.35	12.00	0.350	5.000	0.544	9.647	1.177	4.60	27.6	-
S 12x31.8	7 9 11 12 14 15 20 25 30 33 34 35	31.8	9.26	12.00	0.350	5.000	0.544	9.647	1.177	4.60	27.6	-
S 12x31.67	25	31.67	9.31	12.00	0.369	5.029	0.508	9.695	1.153	4.95	26.3	-
S 12x31.5	27	31.5	9.27	12.00	0.350	5.000	0.545	9.643	1.179	4.59	27.6	-
S 12x31.5	23 24	31.5	9.30	12.00	0.350	5.130	0.525	9.619	1.191	4.89	27.5	-
S 12x31.5	17 26	31.5	9.30	12.00	0.350	5.000	0.545	9.645	1.178	4.59	27.6	-
S 12x31.5	4 10 13 19 21 28	31.5	9.26	12.00	0.350	5.000	0.544	9.647	1.177	4.60	27.6	-
S 12x30.6	26	30.6	9.01	12.00	0.340	5.000	0.505	9.679	1.161	4.95	28.5	-
S 12x30.5	25	30.5	8.96	12.00	0.340	5.000	0.508	9.695	1.153	4.92	28.5	-
S 12x30	16	30.0	9.10	12.00	0.312	5.218	0.516	9.633	1.184	5.06	30.9	-
S 12x28	33	28.0	8.24	11.88	0.314	6.569	0.370	10.200	0.840	8.88	32.5	61
S 12x28	6	28.0	8.15	12.00	0.284	6.000	0.410	10.360	0.820	7.32	36.5	48
S 12x27.9	866 7	27.9	8.15	12.00	0.284	6.000	0.410	10.360	0.820	7.32	36.5	48
S 12x27.5	31	27.5	8.09	12.00	0.301	5.061	0.464	9.882	1.059	5.46	32.8	60
S 12x27.5	29	27.5	8.09	12.00	0.255	5.000	0.513	9.786	1.107	4.88	38.4	44
S 12x27.5	5	27.5	8.04	12.00	0.255	5.000	0.513	9.786	1.107	4.88	38.4	44
S 12x25	33	25.0	7.35	11.88	0.240	6.495	0.355	10.200	0.840	9.15	42.5	36
S 12x25	8	25.0	7.35	12.00	0.270	5.000	0.420	10.284	0.858	5.95	38.1	44
S 12x25	31	25.0	7.35	12.00	0.240	5.000	0.464	9.882	1.059	5.39	41.2	38
S 10x45	23	45.0	13.14	10.00	0.450	5.250	0.900	6.823	1.589	2.92	15.2	-
S 10x40	24	40.0	11.80	10.00	0.580	5.210	0.645	7.483	1.259	4.04	12.9	-
S 10x40	4 11 12 15 17 20 22 30 31	40.0	11.76	10.00	0.749	5.099	0.492	7.843	1.078	5.19	10.5	-
S 10x40	28	40.0	11.75	10.00	0.590	5.150	0.620	7.352	1.324	4.15	12.5	-
S 10x40	2 3	40.0	11.70	10.00	0.570	5.200	0.645	7.483	1.259	4.03	13.1	-
S 10x40	19	40.0	11.69	10.00	0.751	5.101	0.492	7.843	1.078	5.19	10.4	-
S 10x40	7 13 16 21 33	40.0	11.69	10.00	0.741	5.091	0.492	7.843	1.078	5.18	10.6	-
S 10x40	18	40.0	11.31	10.00	0.552	5.180	0.626	7.517	1.242	4.14	13.6	-
S 10x35	19	35.0	10.32	10.00	0.604	4.954	0.492	7.843	1.078	5.04	13.0	-
S 10x35	3	35.0	10.30	10.00	0.430	5.060	0.645	7.483	1.259	3.92	17.4	-
S 10x35	4 11 12 15 17 20 22 30 31	35.0	10.29	10.00	0.602	4.952	0.492	7.843	1.078	5.04	13.0	-
S 10x35	28	35.0	10.27	10.00	0.440	5.000	0.620	7.352	1.324	4.03	16.7	-
S 10x35	7 10 13 14 16 21 33 34 35	35.0	10.22	10.00	0.594	4.944	0.492	7.843	1.078	5.03	13.2	-
S 10x34.9	27	34.9	10.28	10.00	0.500	4.900	0.575	7.559	1.221	4.26	15.1	-
S 10x33	1 2 3	33.0	9.70	10.00	0.370	5.000	0.645	7.483	1.259	3.88	20.2	-
S 10x33	29	33.0	9.70	10.00	0.350	5.000	0.645	7.483	1.259	3.88	21.4	-
S 10x33	23 24	33.0	9.67	10.00	0.370	5.000	0.645	7.483	1.259	3.88	20.2	-
S 10x32	2	32.0	9.40	10.00	0.510	4.940	0.485	7.823	1.089	5.09	15.3	-
S 10x32	18	32.0	9.40	10.00	0.313	4.937	0.626	7.517	1.242	3.95	24.0	-
S 10x31.5	18	31.5	9.24	10.00	0.508	4.945	0.469	7.893	1.054	5.27	15.5	-
S 10x30.3	27	30.3	8.91	10.00	0.500	4.700	0.445	7.839	1.081	5.28	15.7	-
S 10x30.13	26	30.13	8.74	10.00	0.500	4.700	0.445	7.943	1.029	5.28	15.9	-
S 10x30.0	3	30.0	8.95	10.00	0.455	4.885	0.485	7.823	1.089	5.04	17.2	-
S 10x30.0	19	30.0	8.85	10.00	0.457	4.807	0.492	7.843	1.078	4.89	17.2	-
S 10x30.0	31	30.0	8.82	10.00	0.455	4.805	0.492	7.843	1.078	4.89	17.2	-
S 10x30.0	28	30.0	8.82	10.00	0.440	4.790	0.490	7.849	1.075	4.89	17.8	-
S 10x30.0	24	30.0	8.80	10.00	0.450	4.890	0.485	7.823	1.089	5.04	17.4	-
S 10x30.0	7 13 16 21 33	30.0	8.75	10.00	0.447	4.797	0.492	7.843	1.078	4.88	17.5	-
S 10x29.8	27	29.8	8.78	10.00	0.350	4.750	0.575	7.559	1.221	4.13	21.6	-

Table 2.3.1 Dimensions and Primary Properties -- Steel Sections 1887-1952

Designation	X ₁ ksi	X ₂ x 106 (1/ksi) ²	Elastic Properties						Plastic Modulus	
			Axis x-x			Axis y-y			Z _x in.3	Z _y in.3
			I _x in.4	S _x in.3	r _x in.	I _y in.4	S _y in.3	r _y in.		
S12x44.1	4822	475	253.9	42.3	4.41	11.4	4.3	0.93	51.6	7.92
S 12x40.8	4068	681	270.9	45.1	4.75	13.8	5.3	1.07	52.3	8.89
S 12x40.8	4068	672	268.9	44.8	4.77	13.8	5.3	1.08	52.3	8.89
S 12x40	4068	672	268.9	44.8	4.77	13.8	5.3	1.08	52.3	8.89
S 12x40	3871	738	281.3	46.9	4.90	16.8	6.1	1.20	53.9	10.01
S 12x40	3930	726	274.7	45.8	4.83	14.3	5.4	1.10	52.2	9.06
S 12x40	4054	672	268.9	44.8	4.77	13.8	5.3	1.08	52.3	8.89
S 12x40	4129	761	245.9	41.0	4.57	11.0	4.2	0.96	49.1	7.55
S 12x40	3970	658	281.3	46.9	4.90	16.8	6.1	1.20	54.7	10.17
S 12x40	3855	738	281.3	46.9	4.90	16.8	6.1	1.20	53.9	10.01
S 12x39.4	3901	762	268.3	44.7	4.81	14.6	5.6	1.12	51.7	9.09
S 12x39	3904	898	247.5	41.3	4.64	12.1	4.5	1.03	48.9	7.89
S 12x39	4061	857	235.6	39.3	4.52	10.4	4.0	0.95	47.1	7.15
S 12x38.4	3915	967	233.8	39.0	4.55	10.2	3.9	0.95	46.1	6.94
S 12x38	3654	949	265.4	44.2	4.86	15.6	5.7	1.18	50.5	9.31
S 12x37.5	3846	1013	238.7	39.8	4.58	11.5	4.3	1.00	47.3	7.51
S 12x36.6	3743	1124	226.9	37.8	4.58	10.1	3.9	0.97	44.9	6.82
S 12x36	3557	1211	236.7	39.5	4.73	11.5	4.3	1.04	46.2	7.47
S 12x35	3445	1349	232.9	38.8	4.77	10.5	4.0	1.01	44.6	6.98
S 12x35	3549	1242	228.3	38.0	4.71	10.1	4.0	0.99	44.6	6.86
S 12x35	3552	1238	228.3	38.0	4.71	10.1	4.0	0.99	44.6	6.86
S 12x35	3441	1370	231.0	38.5	4.74	10.0	4.0	0.99	44.1	6.78
S 12x35	3517	1279	227.0	37.8	4.72	10.0	3.9	0.99	44.3	6.81
S 12x34.1	3443	1472	217.9	36.3	4.66	9.7	3.8	0.98	42.6	6.49
S 12x32	3285	1406	229.2	38.2	4.92	11.6	4.4	1.11	44.1	7.46
S 12x32	3179	1701	222.3	37.0	4.85	10.3	3.9	1.04	42.6	6.97
S 12x31.8	3210	1689	217.0	36.2	4.82	9.5	3.8	1.01	41.5	6.44
S 12x31.8	3212	1670	215.8	36.0	4.83	9.5	3.8	1.01	41.5	6.44
S 12x31.67	3189	1867	209.1	34.9	4.74	9.2	3.7	0.99	40.4	6.20
S 12x31.5	3177	1702	218.2	36.5	4.86	9.5	3.8	1.01	41.6	6.44
S 12x31.5	3102	1871	220.5	36.7	4.88	10.3	4.0	1.04	41.3	6.54
S 12x31.5	3223	1663	215.8	36.0	4.82	9.5	3.8	1.01	41.5	6.44
S 12x31.5	3212	1670	215.8	36.0	4.83	9.5	3.8	1.01	41.5	6.44
S 12x30.6	2954	2269	207.9	35.7	4.80	9.0	3.6	1.00	39.2	6.00
S 12x30.5	3081	2067	204.9	34.2	4.78	9.0	3.6	1.00	39.4	6.07
S 12x30	3037	2110	211.7	35.3	4.82	10.2	3.9	1.05	40.2	6.53
S 12x28	2306	6134	193.6	32.6	4.85	13.9	4.3	1.30	37.7	7.51
S 12x28	2277	6165	199.4	33.2	4.95	12.6	4.2	1.24	37.4	6.90
S 12x27.9	2277	6165	199.4	33.2	4.95	12.6	4.2	1.24	37.4	6.90
S 12x27.5	2737	3123	191.5	31.9	4.88	8.0	3.2	0.99	36.2	5.44
S 12x27.5	2768	2716	199.6	33.3	4.98	8.7	3.5	1.04	37.1	5.84
S 12x27.5	2760	2716	199.6	33.3	4.98	8.7	3.5	1.04	37.1	5.84
S 12x25	1994	9790	182.8	30.8	4.98	13.4	4.1	1.35	34.0	6.80
S 12x25	2349	5720	175.5	29.2	4.89	7.3	2.9	1.00	32.7	4.89
S 12x25	2546	3769	182.7	30.5	4.99	7.6	3.0	1.02	34.0	5.20
S 10x45	6063	116	216.1	43.2	4.06	17.9	6.8	1.17	50.5	11.86
S 10x40	5296	249	178.5	35.7	3.89	13.5	5.2	1.07	42.4	8.86
S 10x40	6158	177	158.7	31.7	3.67	9.5	3.7	0.90	39.0	7.08
S 10x40	5346	247	175.5	35.1	3.86	12.4	4.8	1.03	41.2	8.33
S 10x40	5235	258	178.0	35.6	3.90	13.4	5.2	1.07	42.1	8.80
S 10x40	6137	176	158.9	31.8	3.68	9.5	3.7	0.90	39.1	7.09
S 10x40	6090	184	158.0	31.6	3.68	9.4	3.7	0.90	38.8	7.03
S 10x40	5073	290	172.9	34.6	3.91	12.7	4.9	1.06	40.9	8.39
S 10x35	5068	348	146.6	29.3	3.77	8.5	3.4	0.91	35.4	6.28
S 10x35	4604	384	166.1	33.2	4.02	12.3	4.9	1.09	38.6	8.03
S 10x35	5046	352	146.4	29.3	3.77	8.5	3.4	0.91	35.3	6.27
S 10x35	4611	396	163.1	32.6	3.99	11.2	4.5	1.04	37.5	7.52
S 10x35	4987	367	145.8	29.2	3.78	8.5	3.4	0.91	35.1	6.23
S 10x34.9	4738	402	153.9	30.8	3.87	10.0	4.1	0.99	36.3	6.92
S 10x33	4367	444	161.3	32.3	4.08	11.8	4.7	1.10	37.1	7.74
S 10x33	3875	580	179.6	35.9	4.54	11.8	4.7	1.10	36.8	7.70
S 10x33	4361	444	161.3	32.3	4.08	11.8	4.7	1.10	37.1	7.74
S 10x32	4422	550	139.4	27.9	3.85	8.4	3.4	0.95	33.2	5.97
S 10x32	4215	542	152.6	30.5	4.02	10.8	4.4	1.07	34.9	7.17
S 10x31.5	4347	597	136.6	27.3	3.84	8.2	3.3	0.94	32.5	5.81
S 10x30.3	4323	637	129.1	25.8	3.81	6.7	2.9	0.87	30.3	5.03
S 10x30.13	4288	655	126.8	25.4	3.81	6.7	2.8	0.87	30.3	5.06
S 10x30.0	4140	699	134.6	26.9	3.88	8.1	3.3	0.95	31.8	5.71
S 10x30.0	4141	682	134.4	26.9	3.90	7.7	3.2	0.93	31.7	5.58
S 10x30.0	4138	684	134.2	26.8	3.90	7.7	3.2	0.93	31.7	5.57
S 10x30.0	3998	768	135.4	27.1	3.92	7.6	3.2	0.93	31.2	5.49
S 10x30.0	4080	716	134.5	26.9	3.90	8.1	3.3	0.96	31.7	5.71
S 10x30.0	4091	710	133.5	26.7	3.91	7.6	3.2	0.93	31.5	5.53
S 10x29.8	4061	644	141.4	28.3	4.01	9.0	3.8	1.01	32.6	6.23

Table 2.3.1 Dimensions and Primary Properties -- Steel Sections 1887-1952

Designation	X ₁ ksi	X ₂ x 106 (1/ksi) ²	Elastic Properties						Plastic Modulus	
			Axis x-x			Axis y-y			Z _x in.3	Z _y in.3
			I _x	S _x	r _x	I _y	S _y	r _y		
			in.4	in.3	in.	in.4	in.3	in.		
S 10x28	3914	890	121.7	24.3	3.87	6.4	2.7	0.88	28.8	4.80
S 10x27	3667	984	127.4	25.5	4.00	7.6	3.2	0.98	29.7	5.38
S 10x25.9	3560	1203	116.4	23.3	3.94	6.1	2.6	0.90	27.2	4.55
S 10x25.5	3470	1179	123.7	24.7	4.06	7.3	3.1	0.99	28.4	5.16
S 10x25.5	3058	1734	137.3	27.5	4.52	7.3	3.1	0.99	29.8	5.14
S 10x25.4	3454	1200	122.9	24.6	4.06	6.9	3.0	0.96	28.0	4.98
S 10x25.4	3461	1180	122.1	24.4	4.07	6.9	3.0	0.97	28.0	4.98
S 10x25.33	3470	1179	123.6	24.7	4.06	7.3	3.1	0.99	28.4	5.16
S 10x25	3459	1214	122.5	24.5	4.06	7.3	3.1	0.99	28.2	5.13
S 10x25	3459	1180	122.1	24.4	4.07	6.9	3.0	0.97	28.0	4.98
S 10x25	3411	1217	123.1	24.6	4.10	6.8	2.9	0.96	28.0	4.97
S 10x25	3415	1210	122.5	24.5	4.06	7.3	3.1	0.99	28.2	5.15
S 10x23.8	3238	1502	117.7	23.5	3.88	7.1	3.0	0.95	26.8	4.89
S 10x23.5	3251	1581	112.4	22.5	4.03	5.8	2.6	0.91	25.3	4.25
S 10x23.33	3251	1632	110.2	22.0	4.00	5.7	2.6	0.91	25.3	4.28
S 10x23	2532	4081	112.1	22.6	4.09	9.6	3.3	1.19	25.4	5.47
S 10x22.4	2469	4233	113.6	22.7	4.17	9.0	3.3	1.17	25.4	5.33
S 10x22.25	2469	4233	113.6	22.7	4.17	9.0	3.3	1.17	25.4	5.33
S 10x22	3009	1860	113.9	22.8	4.18	6.4	2.7	0.99	25.3	4.55
S 10x22	2636	3299	110.3	22.1	4.15	6.9	2.8	1.03	24.5	4.58
S 10x21	2338	5074	107.5	21.7	4.17	9.3	3.2	1.22	24.2	5.31
S 9x35	5567	205	126.6	28.1	3.50	10.9	4.4	1.03	33.4	7.46
S 9x35	6467	144	112.8	25.1	3.31	7.3	3.1	0.84	30.4	5.80
S 9x35	6743	122	112.9	25.0	3.31	7.4	3.1	0.84	30.9	5.92
S 9x35	6797	121	111.8	24.8	3.29	7.3	3.1	0.84	30.9	5.92
S 9x35	6650	132	111.8	24.8	3.29	7.3	3.1	0.84	30.6	5.84
S 9x35	6534	141	111.8	24.8	3.30	7.2	3.0	0.84	30.4	5.78
S 9x35	6576	137	111.3	24.7	3.30	7.3	3.0	0.84	30.4	5.80
S 9x33	5182	256	122.6	27.2	3.55	10.4	4.2	1.04	32.1	7.13
S 9x30	5399	272	102.7	22.8	3.38	6.5	2.8	0.85	27.6	5.13
S 9x30	4777	364	112.1	24.9	3.54	8.9	3.6	0.99	29.3	6.20
S 9x30	5198	313	102.5	22.8	3.39	7.0	2.9	0.88	27.4	5.25
S 9x30	5404	267	101.9	22.6	3.40	6.4	2.8	0.85	27.6	5.13
S 9x30	5280	293	101.9	22.6	3.40	6.4	2.8	0.85	27.3	5.07
S 9x30	5221	305	101.4	22.5	3.40	6.4	2.8	0.85	27.1	5.03
S 9x30	5172	312	102.8	22.8	3.41	6.4	2.8	0.85	27.2	5.04
S 9x30	5208	309	101.9	22.6	3.40	6.4	2.8	0.85	27.1	5.03
S 9x30	4678	350	116.6	25.9	3.63	9.7	4.0	1.05	30.1	6.67
S 9x28.6	5122	341	96.0	21.3	3.38	5.1	2.2	0.78	25.8	4.67
S 9x28.33	4759	419	99.0	22.0	3.45	6.7	2.8	0.89	26.3	5.00
S 9x27	4273	449	110.6	24.6	3.72	9.1	3.8	1.07	28.1	6.25
S 9x26	4287	596	94.3	21.0	3.50	6.3	2.7	0.90	24.8	4.71
S 9x25.4	4208	665	90.5	20.1	3.48	5.3	2.4	0.84	23.4	4.18
S 9x25	4268	595	92.8	20.6	3.52	5.7	2.6	0.87	24.3	4.46
S 9x25	4178	637	91.9	20.4	3.54	5.7	2.5	0.88	24.0	4.41
S 9x25	4269	584	91.9	20.4	3.54	5.7	2.5	0.88	24.3	4.46
S 9x25	4125	663	91.4	20.3	3.54	5.6	2.5	0.88	23.8	4.37
S 9x25	4084	697	92.0	20.4	3.54	5.6	2.5	0.87	23.7	4.35
S 9x25	4054	702	92.8	20.6	3.56	5.6	2.5	0.87	23.7	4.36
S 9x25	4031	720	92.3	20.5	3.54	6.1	2.6	0.91	24.0	4.56
S 9x24.5	3912	642	101.1	22.5	3.74	7.8	3.3	1.04	25.7	5.47
S 9x24.5	3531	1150	83.4	18.5	3.62	5.0	2.2	0.88	21.4	3.98
S 9x23.33	3780	892	89.0	19.8	3.60	5.9	2.6	0.93	23.0	4.39
S 9x21.8	3596	1017	85.6	19.0	3.65	5.2	2.4	0.90	21.7	4.01
S 9x21.8	3590	1006	84.9	18.9	3.67	5.2	2.4	0.90	21.7	4.01
S 9x21.45	3595	993	85.2	18.9	3.67	5.2	2.4	0.90	21.7	4.02
S 9x21	3587	1006	84.9	18.9	3.67	5.2	2.4	0.90	21.7	4.01
S 9x21	3428	1194	84.3	18.7	3.70	5.6	2.5	0.95	21.4	4.13
S 9x21	3550	1006	84.9	18.9	3.67	5.2	2.4	0.90	21.7	4.01
S 9x21	3526	1055	84.0	18.7	3.68	5.2	2.4	0.90	21.4	3.96
S 9x21	3561	990	84.9	18.9	3.71	5.1	2.3	0.91	21.7	4.02
S 9x20.5	3307	1427	80.8	18.0	3.66	4.7	2.2	0.88	20.1	3.64
S 9x20.03	3350	1349	79.0	17.6	3.63	4.7	2.2	0.89	20.1	3.67
S 9x19.75	3254	1427	79.8	17.8	3.71	5.0	2.3	0.92	20.3	3.81
S 8x32	5602	200	82.9	20.7	3.11	7.8	3.2	0.95	24.5	5.77
S 8x28.33	5422	221	81.9	20.5	3.13	7.8	3.3	0.97	24.2	5.68
S 8x27	5111	268	79.8	20.0	3.16	7.6	3.2	0.97	23.4	5.48
S 8x27	5245	252	77.6	19.4	3.14	6.9	3.0	0.93	22.9	5.19
S 8x25.5	5635	225	68.7	17.2	3.02	4.8	2.2	0.80	20.7	4.06
S 8x25.5	5607	229	68.5	17.1	3.02	4.8	2.2	0.80	20.7	4.05
S 8x25.5	5643	223	68.4	17.1	3.02	4.8	2.2	0.80	20.7	4.06
S 8x25.5	5597	230	68.4	17.1	3.02	4.8	2.2	0.80	20.6	4.04
S 8x25.5	5464	248	69.1	17.3	3.04	4.7	2.2	0.79	20.5	4.00
S 8x25.5	5497	247	68.4	17.1	3.02	4.7	2.2	0.79	20.5	4.00
S 8x25.5	5522	241	68.1	17.0	3.03	4.7	2.2	0.80	20.5	4.01
S 8x25.25	5547	232	68.6	17.2	3.04	4.8	2.2	0.80	20.7	4.05

Table 2.3.1 Dimensions and Primary Properties -- Steel Sections 1887-1952

Designation	Source Reference Number	Wt. per ft lb	Area	Depth	Web Thickness	Flange Width	Average Flange Thickness	Distance	Distance	Compact Section Criteria		
			A in.2	d in.	t_w in.	b_f in.	t_f in.	T in.	k in.	$b_f/2t_f$	h/t_w	F_y^m ksi
S 8x25.25	14 15	25.25	7.43	8.00	0.530	4.260	0.426	6.094	0.953	5.01	11.5	-
S 8x25	3	25.0	7.37	8.00	0.510	4.510	0.410	6.136	0.932	5.50	12.0	-
S 8x25	27	25.0	7.35	8.00	0.510	4.510	0.410	6.136	0.932	5.50	12.0	-
S 8x25	19	25.0	7.30	8.00	0.287	4.537	0.500	5.936	1.032	4.54	20.7	-
S 8x25	19	25.0	7.30	8.00	0.507	4.507	0.407	6.122	0.939	5.54	12.1	-
S 8x25	29	25.0	7.30	8.00	0.400	4.490	0.500	5.956	1.022	4.49	14.9	-
S 8x24.3	30	24.3	7.15	8.00	0.520	4.260	0.390	6.166	0.917	5.46	11.9	-
S 8x23	23	23.0	6.80	8.00	0.454	4.184	0.426	6.094	0.953	4.92	13.4	-
S 8x23	21	23.0	6.79	8.00	0.451	4.181	0.426	6.094	0.953	4.91	13.5	-
S 8x23	34 35	23.0	6.76	8.00	0.454	4.184	0.426	6.094	0.953	4.92	13.4	-
S 8x23	4 9 11 17 18 22 24 26	23.0	6.76	8.00	0.449	4.179	0.426	6.094	0.953	4.91	13.6	-
S 8x23	32	23.0	6.76	8.00	0.440	4.170	0.425	6.046	0.977	4.91	13.7	-
S 8x23	36	23.0	6.76	8.00	0.440	4.170	0.426	6.094	0.953	4.90	13.9	-
S 8x23	7 8 10 12 13 16 25 37 38 39	23.0	6.71	8.00	0.441	4.171	0.426	6.094	0.953	4.90	13.8	-
S 8x22.75	20	22.75	6.79	8.00	0.451	4.181	0.426	6.094	0.953	4.91	13.5	-
S 8x22.75	14 15	22.75	6.69	8.00	0.440	4.170	0.426	6.094	0.953	4.90	13.9	-
S 8x22	1 2 27 33	22.0	6.50	8.00	0.270	4.500	0.510	5.916	1.042	4.41	21.9	-
S 8x22	28	22.0	6.40	8.00	0.290	4.380	0.500	5.956	1.022	4.38	20.5	-
S 8x23	37	23.0	6.77	8.00	0.460	5.470	0.305	6.555	0.722	8.98	14.3	-
S 8x21.7	2	21.7	6.40	8.00	0.387	4.387	0.410	6.136	0.932	5.35	15.9	-
S 8x21.2	31	21.2	6.24	8.00	0.400	4.140	0.390	6.146	0.927	5.31	15.4	-
S 8x21	36 37	21.0	6.18	8.00	0.380	5.400	0.305	6.555	0.722	8.87	17.3	-
S 8x20.5	23	20.5	6.07	8.00	0.362	4.092	0.426	6.094	0.953	4.81	16.8	-
S 8x20.5	21	20.5	6.06	8.00	0.360	4.090	0.426	6.094	0.953	4.81	16.9	-
S 8x20.5	34 35	20.5	6.03	8.00	0.362	4.092	0.426	6.094	0.953	4.81	16.8	-
S 8x20.5	4 9 11 17 18 22 24 26	20.5	6.03	8.00	0.357	4.087	0.426	6.094	0.953	4.80	17.1	-
S 8x20.5	36	20.5	6.03	8.00	0.350	4.080	0.426	6.094	0.953	4.79	17.4	-
S 8x20.5	32	20.5	6.03	8.00	0.340	4.070	0.425	6.046	0.977	4.79	17.8	-
S 8x20.5	7 10 12 16 25 37	20.5	5.97	8.00	0.349	4.079	0.426	6.094	0.953	4.79	17.5	-
S 8x20.25	20	20.25	6.06	8.00	0.360	4.090	0.426	6.094	0.953	4.81	16.9	-
S 8x20.25	14 15	20.25	5.96	8.00	0.350	4.080	0.426	6.094	0.953	4.79	17.4	-
S 8x20	29	20.0	5.90	8.00	0.320	4.200	0.415	6.136	0.932	5.06	19.2	-
S 8x19	36 37	19.0	5.59	8.00	0.310	5.320	0.305	6.555	0.722	8.74	21.1	-
S 8x18.4	36	18.4	5.41	8.00	0.270	4.000	0.426	6.094	0.953	4.70	22.6	-
S 8x18.4	7 8 10 12 13 16 18 25 35 37 38 39	18.4	5.34	8.00	0.270	4.000	0.426	6.094	0.953	4.70	22.6	-
S 8x18	21	18.0	5.34	8.00	0.270	4.000	0.426	6.094	0.953	4.70	22.6	-
S 8x18	31	18.0	5.33	8.00	0.270	4.000	0.426	6.094	0.953	4.70	22.6	-
S 8x18	1 2 3 27 33	18.0	5.30	8.00	0.250	4.250	0.410	6.136	0.932	5.18	24.5	-
S 8x18	19	18.0	5.30	8.00	0.250	4.250	0.407	6.122	0.939	5.23	24.5	-
S 8x18	32	18.0	5.29	8.00	0.270	4.000	0.425	6.046	0.977	4.71	22.4	-
S 8x18	34	18.0	5.29	8.00	0.270	4.000	0.426	6.094	0.953	4.70	22.6	-
S 8x18	28	18.0	5.20	8.00	0.250	4.130	0.415	6.136	0.932	4.98	24.5	-
S 8x17.75	14	17.75	5.33	8.00	0.270	4.000	0.426	6.094	0.953	4.70	22.6	-
S 8x17.75	20	17.75	5.22	8.00	0.270	4.000	0.426	6.094	0.953	4.70	22.6	-
S 8x17.5	5	17.5	5.15	8.00	0.210	4.330	0.412	6.157	0.921	5.26	29.3	-
S 8x17.5	6	17.5	5.12	8.00	0.220	5.000	0.349	6.660	0.670	7.17	30.3	-
S 8x17.4	31	17.4	5.12	8.00	0.260	4.000	0.390	6.146	0.927	5.13	23.6	-
S 8x17.23	30	17.23	5.07	8.00	0.260	4.000	0.390	6.166	0.917	5.13	23.7	-
S 8x17	36 37	17.0	5.00	8.00	0.240	5.250	0.305	6.555	0.722	8.62	27.3	-
S 7x26.67	21	26.67	7.90	7.00	0.557	4.537	0.500	5.023	0.988	4.54	9.0	-
S 7x25.2	16	25.2	7.40	7.00	0.558	4.556	0.454	5.164	0.918	5.02	9.3	-
S 7x22	2	22.0	6.49	7.00	0.354	4.334	0.500	5.023	0.988	4.33	14.2	-
S 7x22	23	22.0	6.40	7.00	0.360	4.170	0.490	5.097	0.952	4.26	14.2	-
S 7x21.33	21	21.33	6.41	7.00	0.495	4.265	0.390	5.263	0.868	5.47	10.6	-
S 7x20.2	24	20.2	5.94	7.00	0.480	3.990	0.360	5.313	0.843	5.54	11.1	-
S 7x20	18	20.0	5.91	7.00	0.462	3.872	0.392	5.222	0.889	4.94	11.3	-
S 7x20	1 2 21 27	20.0	5.90	7.00	0.270	4.250	0.500	5.023	0.988	4.25	18.6	-
S 7x20	30	20.0	5.88	7.00	0.458	3.868	0.392	5.222	0.889	4.93	11.4	-
S 7x20	26	20.0	5.88	7.00	0.450	3.860	0.390	5.230	0.885	4.95	11.6	-
S 7x20	3	20.0	5.87	7.00	0.420	4.190	0.390	5.263	0.868	5.37	12.5	-
S 7x20	5 6 8 10 11 13 19 25 31 32	20.0	5.83	7.00	0.450	3.860	0.392	5.222	0.889	4.92	11.6	-
S 7x20	22	20.0	5.70	7.00	0.280	4.090	0.490	5.097	0.952	4.17	18.2	-
S 7x19	2	19.0	5.63	7.00	0.377	4.147	0.390	5.263	0.868	5.32	14.0	-
S 7x18.3	16	18.3	5.40	7.00	0.268	4.266	0.454	5.164	0.918	4.70	19.3	-
S 7x18	16	18.0	5.30	7.00	0.365	4.115	0.375	5.352	0.824	5.49	14.7	-
S 7x17.9	25	17.9	5.29	7.00	0.380	3.890	0.360	5.226	0.887	5.40	13.8	-
S 7x17.5	18	17.5	5.17	7.00	0.356	3.766	0.392	5.222	0.889	4.80	14.7	-
S 7x17.5	30	17.5	5.15	7.00	0.353	3.763	0.392	5.222	0.889	4.80	14.8	-
S 7x17.5	26	17.5	5.15	7.00	0.340	3.750	0.390	5.230	0.885	4.81	15.4	-
S 7x17.5	23	17.5	5.10	7.00	0.340	3.980	0.385	5.317	0.842	5.17	15.6	-
S 7x17.5	5 8 10 13 19 31	17.5	5.09	7.00	0.345	3.755	0.392	5.222	0.889	4.79	15.1	-
S 7x15.5	1 2 21 27	15.5	4.60	7.00	0.230	4.000	0.390	5.263	0.868	5.13	22.9	-
S 7x15.3	30	15.3	4.50	7.00	0.250	3.660	0.392	5.222	0.889	4.67	20.9	-
S 7x15.3	32	15.3	4.43	7.00	0.250	3.660	0.392	5.222	0.889	4.67	20.9	-
S 7x15.25	16	15.25	4.50	7.00	0.250	4.000	0.375	5.352	0.824	5.33	21.4	-

Table 2.3.1 Dimensions and Primary Properties -- Steel Sections 1887-1952

Designation	X ₁ ksi	X ₂ x 106 (1/ksi) ²	Elastic Properties						Plastic Modulus	
			Axis x-x			Axis y-y			Z _x in.3	Z _y in.3
			I _x in.4	S _x in.3	r _x in.	I _y in.4	S _y in.3	r _y in.		
S 8x25.25	5504	245	68.0	17.0	3.03	4.7	2.2	0.80	20.5	4.00
S 8x25	5192	298	68.9	17.2	3.06	5.3	2.4	0.85	20.6	4.24
S 8x25	5185	298	68.8	17.2	3.06	5.3	2.4	0.85	20.6	4.24
S 8x25	4472	479	71.8	17.9	3.13	6.7	2.9	0.95	20.5	4.82
S 8x25	5167	302	68.4	17.1	3.06	5.2	2.3	0.85	20.4	4.17
S 8x25	4766	344	74.4	18.6	3.20	6.6	2.9	0.95	21.7	4.90
S 8x24.3	5346	287	64.3	16.1	3.00	3.8	1.8	0.73	19.4	3.72
S 8x23	4887	363	64.8	16.2	3.09	4.4	2.1	0.81	19.3	3.73
S 8x23	4869	369	64.6	16.2	3.08	4.4	2.1	0.81	19.2	3.72
S 8x23	4900	359	64.5	16.1	3.09	4.4	2.1	0.81	19.3	3.73
S 8x23	4861	371	64.5	16.1	3.09	4.4	2.1	0.81	19.2	3.72
S 8x23	4762	393	65.2	16.3	3.10	4.4	2.1	0.80	19.0	3.68
S 8x23	4791	393	64.5	16.1	3.09	4.4	2.1	0.81	19.0	3.68
S 8x23	4811	386	64.2	16.0	3.09	4.4	2.1	0.81	19.0	3.69
S 8x22.75	4869	369	64.6	16.2	3.08	4.4	2.1	0.81	19.2	3.72
S 8x22.75	4796	388	64.1	16.0	3.10	4.4	2.1	0.81	19.0	3.68
S 8x22	4222	472	71.9	18.0	3.33	6.6	2.9	1.01	20.4	4.81
S 8x22	4237	484	69.7	17.4	3.30	6.0	2.8	0.97	19.9	4.53
S 8x23	4070	753	65.4	16.4	3.10	7.1	2.6	1.02	19.1	4.51
S 8x21.7	4294	562	63.7	15.9	3.15	4.9	2.2	0.87	18.6	3.81
S 8x21.2	4340	573	60.3	15.1	3.11	4.0	1.9	0.80	17.5	3.30
S 8x21	3464	1321	62.3	15.6	3.18	6.8	2.5	1.05	17.8	4.27
S 8x20.5	4260	568	60.8	15.2	3.17	4.1	2.0	0.82	17.8	3.44
S 8x20.5	4250	573	60.7	15.2	3.17	4.1	2.0	0.82	17.8	3.43
S 8x20.5	4277	560	60.6	15.1	3.17	4.1	2.0	0.82	17.8	3.44
S 8x20.5	4246	577	60.6	15.1	3.17	4.1	2.0	0.82	17.7	3.42
S 8x20.5	4175	609	60.6	15.2	3.17	4.0	2.0	0.82	17.6	3.40
S 8x20.5	4114	637	61.3	15.3	3.19	4.0	2.0	0.82	17.4	3.37
S 8x20.5	4175	604	60.2	15.1	3.18	4.0	2.0	0.82	17.6	3.40
S 8x20.25	4250	573	60.7	15.2	3.17	4.1	2.0	0.82	17.8	3.43
S 8x20.25	4206	593	60.2	15.0	3.18	4.0	2.0	0.82	17.6	3.40
S 8x20	3951	748	59.9	15.0	3.22	4.3	2.1	0.86	17.3	3.48
S 8x19	3020	2080	59.2	14.8	3.26	6.5	2.4	1.08	16.7	4.05
S 8x18.4	3770	832	57.3	14.3	3.25	3.8	1.9	0.84	16.3	3.17
S 8x18.4	3772	821	56.9	14.2	3.26	3.8	1.9	0.84	16.3	3.17
S 8x18	3764	824	56.9	14.2	3.26	3.8	1.9	0.84	16.3	3.17
S 8x18	3768	821	56.9	14.2	3.27	3.8	1.9	0.84	16.3	3.17
S 8x18	3567	987	57.8	14.4	3.30	4.4	2.1	0.91	16.4	3.42
S 8x18	3577	991	57.3	14.3	3.28	4.3	2.0	0.89	16.3	3.37
S 8x18	3751	812	57.4	14.3	3.29	3.7	1.9	0.84	16.3	3.17
S 8x18	3754	821	56.9	14.2	3.27	3.8	1.9	0.84	16.3	3.17
S 8x18	3575	967	56.8	14.2	3.30	4.0	1.9	0.87	16.2	3.29
S 8x17.75	3768	821	56.9	14.2	3.27	3.8	1.9	0.84	16.3	3.17
S 8x17.75	3729	821	56.9	14.2	3.31	3.8	1.9	0.84	16.3	3.17
S 8x17.5	3384	1119	58.3	14.6	3.37	4.5	2.1	0.93	16.2	3.45
S 8x17.5	2772	2497	58.4	14.6	3.38	6.2	2.5	1.10	16.2	4.03
S 8x17.4	3498	1126	54.3	13.6	3.26	3.5	1.8	0.83	15.2	2.92
S 8x17.23	3534	1104	53.2	13.3	3.24	3.5	1.8	0.83	15.2	2.94
S 8x17	2665	3065	56.0	14.0	3.35	6.2	2.4	1.11	15.6	3.87
S 7x26.67	6522	109	57.9	16.5	2.71	6.9	3.0	0.93	19.7	5.22
S 7x25.2	6239	130	54.7	15.6	2.72	6.1	2.7	0.91	18.7	4.81
S 7x22	5161	231	52.1	14.9	2.83	5.9	2.7	0.95	17.2	4.49
S 7x22	5137	250	50.0	14.3	2.82	5.2	2.5	0.91	16.5	4.12
S 7x21.33	5641	209	46.2	13.2	2.69	4.3	2.0	0.82	15.8	3.60
S 7x20.2	5551	239	42.0	11.9	2.64	2.9	1.5	0.70	14.3	2.98
S 7x20	5522	230	42.3	12.1	2.68	3.3	1.7	0.74	14.5	3.00
S 7x20	4767	289	49.7	14.2	2.91	5.5	2.6	0.97	16.2	4.23
S 7x20	5465	237	42.2	12.1	2.68	3.2	1.7	0.74	14.4	2.98
S 7x20	5328	258	42.6	12.2	2.69	3.2	1.7	0.74	14.3	2.95
S 7x20	4997	313	44.0	12.6	2.74	4.1	1.9	0.83	14.8	3.37
S 7x20	5412	246	41.9	12.0	2.68	3.1	1.6	0.74	14.3	2.96
S 7x20	4696	314	47.6	13.6	2.85	4.9	2.4	0.92	15.6	3.88
S 7x19	4692	391	42.8	12.2	2.76	3.9	1.9	0.83	14.3	3.24
S 7x18.3	4318	416	46.4	13.3	2.93	5.0	2.4	0.96	15.1	3.86
S 7x18	4422	474	41.2	11.8	2.79	4.3	2.1	0.90	13.8	3.09
S 7x17.9	4658	423	39.4	11.3	2.75	3.0	1.6	0.76	13.0	2.68
S 7x17.5	4648	406	39.3	11.2	2.76	3.0	1.6	0.76	13.2	2.70
S 7x17.5	4629	412	39.2	11.2	2.76	2.9	1.6	0.76	13.1	2.69
S 7x17.5	4472	465	39.6	11.3	2.77	2.9	1.6	0.75	12.9	2.65
S 7x17.5	4352	492	40.1	11.5	2.79	3.4	1.7	0.82	13.4	2.93
S 7x17.5	4584	426	38.9	11.1	2.77	2.9	1.6	0.76	13.0	2.67
S 7x15.5	3835	723	38.6	11.0	2.91	3.5	1.7	0.87	12.5	2.87
S 7x15.3	3999	655	36.5	10.4	2.85	2.7	1.5	0.77	11.9	2.45
S 7x15.3	3968	655	36.2	10.4	2.86	2.7	1.5	0.78	11.9	2.45
S 7x15.25	3738	799	37.9	10.8	2.89	3.4	1.7	0.86	12.4	2.80

Table 2.3.1 Dimensions and Primary Properties -- Steel Sections 1887-1952

Designation	Source Reference Number	Wt. per ft lb	Area	Depth	Web Thickness	Flange Width	Average Flange Thickness	Distance	Distance	Compact Section Criteria		
			A	d	t _w	b _f	t _f	T	k	b _f /2t _f	h/t _w	F _y "
			in.2	in.	in.	in.	in.	in.	in.	in.		
S 7x15	26	15.0	4.42	7.00	0.250	3.660	0.390	5.230	0.885	4.69	20.9	-
S 7x15	29	15.0	4.42	7.00	0.250	3.660	0.392	5.222	0.889	4.67	20.9	-
S 7x15	3	15.0	4.40	7.00	0.210	3.980	0.390	5.263	0.868	5.10	25.1	-
S 7x15	22	15.0	4.40	7.00	0.230	3.880	0.385	5.317	0.842	5.04	23.1	-
S 7x14.6	25	14.6	4.31	7.00	0.240	3.750	0.360	5.226	0.887	5.21	21.8	-
S 7x14.6	24	14.6	4.26	7.00	0.240	3.750	0.360	5.313	0.843	5.21	22.1	-
S 6x46.1	24 25	46.1	13.56	6.00	0.880	5.500	0.840	2.501	1.750	3.27	2.8	-
S 6x41	24	41.0	12.06	6.00	0.630	5.250	0.840	2.501	1.750	3.13	4.0	-
S 6x41	25	41.0	12.06	6.00	0.630	5.250	0.840	2.501	1.750	3.13	4.0	-
S 6x37.4	24	37.4	10.99	6.00	0.750	5.130	0.685	2.881	1.560	3.74	3.8	-
S 6x37.4	25	37.4	10.99	6.00	0.750	5.130	0.685	2.881	1.560	3.74	3.8	-
S 6x32.3	24	32.3	9.49	6.00	0.500	4.880	0.685	2.881	1.560	3.56	5.8	-
S 6x32.3	25	32.3	9.49	6.00	0.500	4.880	0.685	2.881	1.560	3.56	5.8	-
S 6x27.7	26	27.7	8.15	6.00	0.566	4.936	0.525	3.619	1.191	4.70	6.4	-
S 6x23.9	26	23.9	7.03	6.00	0.380	4.750	0.525	3.619	1.191	4.52	9.5	-
S 6x21.67	20	21.67	6.44	6.00	0.545	3.745	0.495	3.836	1.082	3.78	7.0	-
S 6x20	16	20.0	5.95	6.00	0.481	3.980	0.438	4.279	0.860	4.54	8.9	-
S 6x20	2	20.0	5.88	6.00	0.456	3.821	0.465	4.210	0.895	4.11	9.2	-
S 6x20	22	20.0	5.70	6.00	0.500	3.770	0.425	4.277	0.862	4.44	8.6	-
S 6x18.33	20	18.33	5.44	6.00	0.495	3.245	0.450	3.956	1.022	3.61	8.0	-
S 6x18	3	18.0	5.27	6.00	0.475	3.745	0.375	4.390	0.805	4.99	9.2	-
S 6x17.5	22	17.5	5.00	6.00	0.370	3.640	0.425	4.277	0.862	4.28	11.6	-
S 6x17.25	4 7 9 12 14 15 17 19 28 29	17.25	5.07	6.00	0.475	3.575	0.359	4.347	0.826	4.98	9.2	-
S 6x17.25	25	17.25	5.07	6.00	0.460	3.560	0.360	4.343	0.828	4.94	9.4	-
S 6x17.25	30	17.25	5.07	6.00	0.460	3.560	0.359	4.347	0.826	4.96	9.5	-
S 6x17.25	5 6 8 10 11 13 18 31 32 33	17.25	5.02	6.00	0.465	3.565	0.359	4.347	0.826	4.97	9.3	-
S 6x16.67	20	16.67	4.97	6.00	0.300	3.500	0.495	3.836	1.082	3.54	12.8	-
S 6x16.6	16	16.6	4.90	6.00	0.265	3.765	0.438	4.279	0.860	4.30	16.1	-
S 6x16.1	23	16.1	4.74	6.00	0.440	3.620	0.330	4.443	0.778	5.48	10.1	-
S 6x16	1 2 27	16.0	4.70	6.00	0.260	3.625	0.465	4.210	0.895	3.90	16.2	-
S 6x15.5	16	15.5	4.51	6.00	0.385	3.635	0.339	4.467	0.766	5.37	11.6	-
S 6x15.2	24	15.2	4.47	6.00	0.380	3.560	0.330	4.473	0.763	5.39	11.8	-
S 6x15	2	15.0	4.39	6.00	0.328	3.598	0.375	4.390	0.805	4.80	13.4	-
S 6x15	21	15.0	4.40	6.00	0.250	3.520	0.425	4.277	0.862	4.14	17.1	-
S 6x14.75	4 7 9 12 14 15 17 19 28 29	14.75	4.34	6.00	0.352	3.452	0.359	4.347	0.826	4.81	12.4	-
S 6x14.75	25	14.75	4.34	6.00	0.340	3.440	0.360	4.343	0.828	4.78	12.8	-
S 6x14.75	30	14.75	4.34	6.00	0.340	3.440	0.359	4.347	0.826	4.79	12.8	-
S 6x14.75	5 6 8 10 13 18 31	14.75	4.29	6.00	0.343	3.443	0.359	4.347	0.826	4.80	12.7	-
S 6x13.33	20	13.33	3.97	6.00	0.250	3.000	0.450	3.956	1.022	3.33	15.8	-
S 6x13	1 2 3 27	13.0	3.80	6.00	0.230	3.500	0.375	4.390	0.805	4.67	19.1	-
S 6x12.75	16	12.75	3.70	6.00	0.250	3.500	0.339	4.467	0.766	5.17	17.9	-
S 6x12.5	30	12.5	3.68	6.00	0.230	3.330	0.359	4.347	0.826	4.64	18.9	-
S 6x12.5	5 6 8 10 11 13 15 18 29 31 32 33	12.5	3.61	6.00	0.230	3.330	0.359	4.347	0.826	4.64	18.9	-
S 6x12.27	24	12.27	3.61	6.00	0.230	3.330	0.360	4.343	0.828	4.63	18.9	-
S 6x12.25	4 7 9 12 14 17 19 28	12.25	3.61	6.00	0.230	3.330	0.359	4.347	0.826	4.64	18.9	-
S 6x12.25	25	12.25	3.60	6.00	0.230	3.330	0.360	4.343	0.828	4.63	18.9	-
S 6x12	21	12.0	3.60	6.00	0.220	3.380	0.335	4.477	0.762	5.04	20.3	-
S 6x11.9	24	11.9	3.51	6.00	0.220	3.400	0.330	4.473	0.763	5.15	20.3	-
S 6x11.6	23	11.6	3.42	6.00	0.220	3.400	0.330	4.443	0.778	5.15	20.2	-
S 5x17.33	20	17.33	5.08	5.00	0.516	3.386	0.435	3.377	0.812	3.89	6.5	-
S 5x16	16	16.0	4.84	5.00	0.486	3.236	0.438	3.331	0.835	3.69	6.9	-
S 5x16	2	16.0	4.70	5.00	0.437	3.307	0.435	3.377	0.812	3.80	7.7	-
S 5x15	3	15.0	4.48	5.00	0.515	3.295	0.335	3.577	0.712	4.92	6.9	-
S 5x15	22	15.0	4.40	5.00	0.380	3.250	0.435	3.377	0.812	3.74	8.9	-
S 5x14.75	4 7 9 12 14 17 19 27 28 15	14.75	4.34	5.00	0.504	3.294	0.327	3.471	0.765	5.04	6.9	-
S 5x14.75	29	14.75	4.34	5.00	0.490	3.280	0.327	3.471	0.765	5.02	7.1	-
S 5x14.75	25	14.75	4.34	5.00	0.490	3.280	0.325	3.477	0.762	5.05	7.1	-
S 5x14.75	5 6 8 12 11 13 18 30 31 32	14.75	4.29	5.00	0.494	3.284	0.327	3.471	0.765	5.03	7.0	-
S 5x14	20	14.0	4.18	5.00	0.456	3.236	0.335	3.577	0.712	4.83	7.8	-
S 5x13	1 2 20 21 26	13.0	3.80	5.00	0.260	3.130	0.435	3.377	0.812	3.60	13.0	-
S 5x13	16	13.0	3.80	5.00	0.310	3.060	0.438	3.331	0.835	3.49	10.7	-
S 5x13	16	13.0	3.78	5.00	0.396	3.020	0.345	3.457	0.772	4.38	8.7	-
S 512.5	23	12.5	3.68	5.00	0.400	3.200	0.300	3.573	0.713	5.33	8.9	-
S 5x12.3	24	12.3	3.61	5.00	0.370	3.170	0.300	3.573	0.713	5.28	9.7	-
S 5x12.25	4 7 9 12 14 15 17 19 27 28	12.25	3.60	5.00	0.357	3.147	0.327	3.471	0.765	4.82	9.7	-
S 5x12.25	25	12.25	3.60	5.00	0.340	3.130	0.325	3.477	0.762	4.82	10.2	-
S 5x12.25	29	12.25	3.60	5.00	0.340	3.130	0.327	3.471	0.765	4.79	10.2	-
S 5x12.25	5 8 10 13 18 30	12.25	3.56	5.00	0.347	3.137	0.327	3.471	0.765	4.80	10.0	-
S 5x12	2	12.0	3.60	5.00	0.338	3.118	0.335	3.577	0.712	4.65	10.6	-
S 5x12	22	12.0	3.60	5.00	0.340	3.130	0.325	3.597	0.702	4.82	10.6	-
S 5x10	1 2 3 20 26	10.0	3.00	5.00	0.220	3.000	0.335	3.577	0.712	4.48	16.3	-
S 5x10	29	10.0	2.94	5.00	0.210	3.000	0.327	3.471	0.765	4.59	16.5	-
S 5x10	16	10.0	2.90	5.00	0.220	2.845	0.345	3.457	0.772	4.12	15.7	-
S 5x10	5 6 8 10 11 13 15 18 28 30 31 32	10.0	2.87	5.00	0.210	3.000	0.327	3.471	0.765	4.59	16.5	-
S 5x9.75	21	9.75	2.90	5.00	0.210	3.000	0.325	3.597	0.702	4.62	17.1	-

Table 2.3.1 Dimensions and Primary Properties – Steel Sections 1887-1952

Designation	X ₁ ksi	X ₂ x 106 (1/ksi) ²	Elastic Properties						Plastic Modulus	
			Axis x-x			Axis y-y			Z _x in.3	Z _y in.3
			I _x in.4	S _x in.3	r _x in.	I _y in.4	S _y in.3	r _y in.		
			in.4	in.3	in.	in.4	in.3	in.	in.3	in.3
S 7x15	3902	684	36.6	10.5	2.88	2.6	1.4	0.78	11.8	2.44
S 7x15	3963	655	36.2	10.4	2.86	2.7	1.5	0.78	11.9	2.45
S 7x15	3714	772	38.0	10.9	2.92	3.4	1.7	0.87	12.3	2.83
S 7x15	3757	775	37.1	10.6	2.89	3.1	1.6	0.84	12.1	2.68
S 7x14.6	3718	857	35.4	10.1	2.87	2.7	1.4	0.79	11.3	2.35
S 7x14.6	3709	886	34.6	9.9	2.85	2.7	1.4	0.79	11.3	2.38
S 6x46.1	13767	5	68.6	22.9	2.25	21.2	7.7	1.25	27.9	12.76
S 6x41	11915	9	64.1	21.4	2.30	17.9	6.8	1.22	25.6	11.22
S 6x41	11948	9	63.9	21.3	2.30	18.2	6.9	1.23	25.6	11.22
S 6x37.4	11316	12	57.0	19.0	2.28	13.9	5.4	1.12	22.6	9.07
S 6x37.4	11442	12	56.3	18.8	2.26	13.8	5.4	1.12	22.6	9.07
S 6x32.3	9439	21	52.5	17.5	2.35	11.7	4.8	1.11	20.4	7.85
S 6x32.3	9554	21	51.8	17.3	2.34	11.7	4.8	1.11	20.4	7.85
S 6x27.7	7944	45	45.5	15.1	2.36	9.0	3.6	1.05	17.6	6.20
S 6x23.9	6639	80	42.0	14.0	2.44	7.9	3.3	1.06	15.9	5.51
S 6x21.67	7999	50	33.6	11.2	2.28	3.7	2.0	0.75	13.6	3.48
S 6x20	6598	104	32.1	10.7	2.32	4.1	2.1	0.83	12.8	3.51
S 6x20	6571	101	32.1	10.7	2.34	3.8	2.0	0.81	12.7	3.42
S 6x20	6669	99	30.8	10.3	2.32	3.4	1.8	0.77	12.2	3.14
S 6x18.33	7422	72	27.8	9.3	2.26	2.1	1.3	0.63	11.3	2.43
S 6x18	6302	132	27.9	9.3	2.30	2.9	1.5	0.74	11.2	2.70
S 6x17.5	5532	186	28.7	9.6	2.39	3.0	1.7	0.78	11.1	2.79
S 6x17.25	6460	127	26.2	8.7	2.27	2.4	1.3	0.68	10.5	2.39
S 6x17.25	6222	144	26.5	8.8	2.29	2.3	1.3	0.68	10.4	2.35
S 6x17.25	6284	142	26.2	8.7	2.27	2.3	1.3	0.68	10.4	2.35
S 6x17.25	6311	137	26.0	8.7	2.28	2.3	1.3	0.68	10.4	2.36
S 6x16.67	6011	124	29.2	9.7	2.42	2.9	1.6	0.76	11.4	2.78
S 6x16.6	5104	248	28.4	9.5	2.40	3.4	1.8	0.83	10.9	2.94
S 6x16.1	5868	184	24.7	8.2	2.28	2.0	1.1	0.65	9.9	2.24
S 6x16	5230	204	28.6	9.5	2.47	3.2	1.8	0.83	11.0	2.90
S 6x15.5	5281	258	24.5	8.2	2.33	2.3	1.3	0.71	9.7	2.20
S 6x15.2	5188	283	24.0	8.0	2.32	2.1	1.2	0.69	9.4	2.08
S 6x15	4950	293	25.3	8.4	2.40	2.5	1.4	0.75	9.8	2.35
S 6x15	4836	290	26.4	8.8	2.47	2.7	1.6	0.79	10.0	2.51
S 6x14.75	5193	264	24.0	8.0	2.35	2.1	1.2	0.69	9.4	2.10
S 6x14.75	5034	291	24.3	8.1	2.36	2.1	1.2	0.69	9.3	2.07
S 6x14.75	5084	287	24.0	8.0	2.35	2.1	1.2	0.69	9.3	2.07
S 6x14.75	5146	274	23.8	7.9	2.36	2.1	1.2	0.69	9.3	2.08
S 6x13.33	5300	207	23.4	7.8	2.43	1.6	1.1	0.64	9.1	1.85
S 6x13	4301	446	23.5	7.8	2.48	2.3	1.3	0.77	9.0	2.14
S 6x12.75	3990	598	23.1	7.7	2.49	2.2	1.3	0.77	8.5	1.93
S 6x12.5	4304	483	22.0	7.3	2.43	1.9	1.1	0.71	8.3	1.85
S 6x12.5	4263	483	21.8	7.3	2.46	1.8	1.1	0.72	8.3	1.85
S 6x12.27	4277	476	21.8	7.3	2.46	1.9	1.1	0.72	8.3	1.86
S 6x12.25	4263	483	21.8	7.3	2.46	1.9	1.1	0.72	8.3	1.85
S 6x12.25	4213	489	22.1	7.4	2.48	1.8	1.1	0.71	8.3	1.86
S 6x12	3879	716	21.7	7.3	2.47	1.9	1.1	0.73	8.0	1.80
S 6x11.9	3913	696	21.1	7.1	2.45	1.8	1.1	0.72	7.9	1.77
S 6x11.6	3951	660	20.8	6.9	2.46	1.9	1.1	0.73	7.9	1.79
S 5x17.33	8394	41	18.4	7.4	1.90	2.6	1.5	0.71	8.9	2.62
S 5x16	8218	44	17.6	7.0	1.91	2.2	1.4	0.68	8.5	2.38
S 5x16	7524	60	17.5	7.0	1.93	2.4	1.4	0.71	8.4	2.43
S 5x15	8034	56	15.5	6.2	1.86	1.8	1.1	0.63	7.6	1.97
S 5x15	6969	76	16.9	6.8	1.97	2.2	1.4	0.71	8.1	2.30
S 5x14.75	7926	57	15.2	6.1	1.87	1.7	1.0	0.63	7.4	1.90
S 5x14.75	7715	64	15.2	6.1	1.87	1.7	1.0	0.62	7.3	1.87
S 5x14.75	7698	65	15.2	6.1	1.87	1.7	1.0	0.62	7.3	1.86
S 5x14.75	7858	60	15.0	6.0	1.87	1.7	1.0	0.63	7.3	1.87
S 5x14	7214	82	14.9	5.9	1.88	1.7	1.0	0.63	7.2	1.84
S 5x13	6020	119	15.7	6.3	2.03	2.0	1.3	0.72	7.3	2.06
S 5x13	6365	94	15.7	6.3	2.02	1.8	1.2	0.69	7.4	1.99
S 5x13	6741	100	13.9	5.5	1.91	1.3	0.9	0.59	6.7	1.56
S 512.5	6369	129	13.4	5.4	1.91	1.2	0.8	0.57	6.4	1.58
S 5x12.3	5952	165	13.3	5.3	1.92	1.4	0.9	0.62	6.3	1.53
S 5x12.25	6122	142	13.6	5.4	1.94	1.5	0.9	0.63	6.5	1.60
S 5x12.25	5798	170	13.7	5.5	1.95	1.4	0.9	0.63	6.4	1.57
S 5x12.25	5926	161	13.6	5.4	1.94	1.4	0.9	0.63	6.4	1.57
S 5x12.25	5972	153	13.5	5.4	1.95	1.4	0.9	0.63	6.4	1.59
S 5x12	5808	171	13.6	5.5	1.95	1.5	1.0	0.64	6.4	1.62
S 5x12	5766	181	13.5	5.4	1.96	1.4	0.9	0.64	6.4	1.58
S 5x10	4764	316	12.4	5.0	2.05	1.3	0.9	0.66	5.7	1.42
S 5x10	4711	327	12.2	4.9	2.04	1.2	0.8	0.65	5.6	1.37
S 5x10	4460	324	13.5	5.4	2.15	1.4	1.0	0.69	5.6	1.27
S 5x10	4752	314	12.1	4.8	2.05	1.2	0.8	0.65	5.6	1.37
S 5x9.75	4557	368	12.1	4.9	2.06	1.3	0.9	0.67	5.5	1.37

Table 2.3.1 Dimensions and Primary Properties -- Steel Sections 1887-1952

Designation	Source Reference Number	Wt. per ft lb	Area	Depth	Web Thickness	Flange Width	Average Flange Thickness	Distance	Distance	Compact Section Criteria		
			A in.2	d in.	t _w in.	b _f in.	t _f in.	T in.	k in.	b/2t _f	h/t _w	F _y " ksi
S 5x9.75	25	9.75	2.87	5.00	0.210	3.000	0.325	3.477	0.762	4.62	16.6	-
S 5x9.75	4 7 9 12 14 17 19 24 27	9.75	2.87	5.00	0.210	3.000	0.327	3.471	0.765	4.59	16.5	-
S 5x9.4	24	9.4	2.76	5.00	0.200	3.000	0.300	3.573	0.713	5.00	17.9	-
S 5x9.1	23	9.1	2.68	5.00	0.200	3.000	0.300	3.573	0.713	5.00	17.9	-
S 4x13.33	19	13.33	3.81	4.00	0.480	2.990	0.390	2.547	0.726	3.83	5.3	-
S 4x13.33	2	13.0	3.79	4.00	0.462	2.972	0.395	2.527	0.736	3.76	5.5	-
S 4x11.46	15	11.46	3.38	4.00	0.375	2.875	0.375	2.571	0.715	3.83	6.9	-
S 4x11.3	21	11.3	3.33	4.00	0.440	2.820	0.330	2.533	0.733	4.27	5.8	-
S 4x10.67	19	10.67	3.13	4.00	0.430	2.950	0.290	2.747	0.626	5.09	6.4	-
S 4x10.5	4 7 12 14 16 18 25 26	10.5	3.09	4.00	0.410	2.880	0.293	2.598	0.701	4.91	6.3	-
S 4x10.5	27	10.5	3.09	4.00	0.400	2.870	0.293	2.598	0.701	4.90	6.5	-
S 4x10.5	23	10.5	3.09	4.00	0.390	2.860	0.295	2.590	0.705	4.85	6.6	-
S 4x10.5	5 8 10 13 17 28	10.5	3.05	4.00	0.400	2.870	0.293	2.598	0.701	4.90	6.5	-
S 4x10.2	15	10.2	3.00	4.00	0.280	2.780	0.375	2.571	0.715	3.71	9.2	-
S 4x10	3	10.0	2.99	4.00	0.390	2.810	0.290	2.747	0.626	4.84	7.0	-
S 4x10	15	10.0	2.94	4.00	0.410	2.850	0.282	2.759	0.621	5.06	6.7	-
S 4x10	1 2 19 24	10.0	2.94	4.00	0.240	2.750	0.395	2.527	0.736	3.48	10.5	-
S 4x10	20	10.0	2.90	4.00	0.390	2.690	0.305	2.677	0.662	4.41	6.9	-
S 4x9.5	4 7 9 12 14 16 18 25 26	9.5	2.79	4.00	0.337	2.807	0.293	2.598	0.701	4.79	7.7	-
S 4x9.5	27	9.5	2.79	4.00	0.320	2.790	0.293	2.598	0.701	4.76	8.1	-
S 4x9.5	23	9.5	2.79	4.00	0.320	2.790	0.295	2.590	0.705	4.73	8.1	-
S 4x9.5	5 6 8 10 11 13 17 28 29 30	9.5	2.76	4.00	0.326	2.796	0.293	2.598	0.701	4.77	8.0	-
S 4x9.4	15	9.4	2.76	4.00	0.375	2.750	0.297	2.675	0.663	4.63	7.1	-
S 4x9	2	9.0	2.64	4.00	0.311	2.736	0.290	2.747	0.626	4.72	8.8	-
S 4x8.5	4 7 9 12 14 16 18 25 26	8.5	2.50	4.00	0.263	2.733	0.293	2.598	0.701	4.66	9.9	-
S 4x8.5	27	8.5	2.50	4.00	0.250	2.720	0.293	2.598	0.701	4.64	10.4	-
S 4x8.5	23	8.5	2.50	4.00	0.240	2.710	0.295	2.590	0.705	4.59	10.8	-
S 4x8.5	5 8 10 13 17 28	8.5	2.46	4.00	0.253	2.723	0.293	2.598	0.701	4.65	10.3	-
S 4x8.4	21	8.4	2.46	4.00	0.320	2.460	0.275	2.774	0.613	4.47	8.7	-
S 4x8.3	21	8.3	2.45	4.00	0.220	2.600	0.330	2.533	0.733	3.94	11.5	-
S 4x8	2	8.0	2.39	4.00	0.328	2.328	0.260	2.697	0.652	4.48	8.2	-
S 4x7.9	15	7.9	2.30	4.00	0.250	2.690	0.282	2.759	0.621	4.78	11.0	-
S 4x7.7	5 6 8 10 11 13 14 17 26 28 29 30	7.7	2.21	4.00	0.190	2.660	0.293	2.598	0.701	4.54	13.7	-
S 4x7.5	27	7.5	2.26	4.00	0.190	2.660	0.293	2.598	0.701	4.54	13.7	-
S 4x7.5	4 7 9 12 16 18 22 25	7.5	2.21	4.00	0.190	2.660	0.293	2.598	0.701	4.54	13.7	-
S 4x7.5	23	7.5	2.20	4.00	0.190	2.660	0.295	2.590	0.705	4.51	13.6	-
S 4x7.5	1 2 19	7.5	2.20	4.00	0.200	2.625	0.290	2.747	0.626	4.53	13.7	-
S 4x7.5	20	7.5	2.20	4.00	0.200	2.500	0.305	2.677	0.662	4.10	13.4	-
S 4x7	3	7.0	2.10	4.00	0.170	2.590	0.290	2.747	0.626	4.47	16.2	-
S 4x6.85	15	6.85	2.00	4.00	0.190	2.560	0.297	2.675	0.663	4.31	14.1	-
S 4x6.2	21	6.2	1.82	4.00	0.160	2.300	0.275	2.774	0.613	4.18	17.3	-
S 4x6	20	6.0	1.80	4.00	0.180	2.190	0.260	2.757	0.622	4.21	15.3	-
S 4x6	2	6.0	1.80	4.00	0.180	2.180	0.260	2.697	0.652	4.19	15.0	-
S 3.5x6	17	6.0	1.77	3.50	0.170	2.330	0.260	2.224	0.638	4.48	13.1	-
S 3.5x5.8	16	5.8	1.72	3.50	0.170	2.330	0.260	2.224	0.638	4.48	13.1	-
S 3x9.07	19	9.07	2.67	3.00	0.440	2.620	0.310	1.573	0.713	4.23	3.6	-
S 3x9	13	9.0	2.60	3.00	0.390	2.520	0.360	1.519	0.741	3.50	3.9	-
S 3x7.5	14 22 23	7.5	2.21	3.00	0.366	2.526	0.260	1.724	0.638	4.86	4.7	-
S 3x7.5	2 5 7 10 12 15 18	7.5	2.21	3.00	0.361	2.521	0.260	1.724	0.638	4.85	4.8	-
S 3x7.5	24	7.5	2.21	3.00	0.350	2.510	0.260	1.724	0.638	4.83	4.9	-
S 3x7.5	21	7.5	2.20	3.00	0.340	2.500	0.260	1.724	0.638	4.81	5.1	-
S 3x7.5	3 4 6 8 9 11 16 17 25 26	7.5	2.17	3.00	0.349	2.509	0.260	1.724	0.638	4.83	4.9	-
S 3x7	13	7.0	2.00	3.00	0.190	2.320	0.360	1.519	0.741	3.23	8.0	-
S 3x7	1	7.0	2.09	3.00	0.298	2.358	0.285	1.697	0.652	4.14	5.7	-
S 3x6.93	19	6.93	2.09	3.00	0.320	2.360	0.265	1.774	0.613	4.45	5.5	-
S 3x6.83	19	6.83	2.01	3.00	0.220	2.400	0.310	1.573	0.713	3.87	7.2	-
S 3x6.8	20	6.8	2.01	3.00	0.310	2.350	0.265	1.693	0.653	4.43	5.5	-
S 3x6.5	14 22 23	6.5	1.91	3.00	0.268	2.428	0.260	1.724	0.638	4.67	6.4	-
S 3x6.5	2 5 7 10 12 15 18	6.5	1.91	3.00	0.263	2.423	0.260	1.724	0.638	4.66	6.6	-
S 3x6.5	24	6.5	1.91	3.00	0.250	2.410	0.260	1.724	0.638	4.63	6.9	-
S 3x6.5	21	6.5	1.91	3.00	0.240	2.400	0.260	1.724	0.638	4.62	7.2	-
S 3x6.5	3 6 8 11 16 17 25	6.5	1.88	3.00	0.251	2.411	0.260	1.724	0.638	4.64	6.9	-
S 3x6.3	13	6.3	1.81	3.00	0.250	2.130	0.282	1.769	0.616	3.78	7.1	-
S 3x6	1	6.0	1.80	3.00	0.200	2.260	0.285	1.697	0.652	3.96	8.5	-
S 3x5.7	24	5.7	1.68	3.00	0.170	2.330	0.260	1.724	0.638	4.48	10.1	-
S 3x5.7	26	5.7	1.64	3.00	0.170	2.330	0.260	1.724	0.638	4.48	10.1	-
S 3x5.5	2 5 7 10 14 15 18	5.5	1.63	3.00	0.170	2.330	0.260	1.724	0.638	4.48	10.1	-
S 3x5.5	22	5.5	1.62	3.00	0.170	2.330	0.260	1.724	0.638	4.48	10.1	-
S 3x5.5	21	5.5	1.62	3.00	0.170	2.330	0.260	1.724	0.638	4.48	10.1	-
S 3x5.3	17	5.3	1.57	3.00	0.156	2.030	0.281	1.738	0.631	3.62	11.1	-
S 3x5.3	20	5.3	1.56	3.00	0.160	2.200	0.265	1.693	0.653	4.15	10.6	-
S 3x5.3	19	5.3	1.56	3.00	0.160	2.200	0.265	1.774	0.613	4.15	11.1	-
S 3x5.2	15	5.2	1.57	3.00	0.156	2.030	0.281	1.738	0.631	3.62	11.1	-
S 3x5.1	13	5.1	1.50	3.00	0.156	2.030	0.282	1.769	0.616	3.61	11.3	-

Table 2.3.1 Dimensions and Primary Properties -- Steel Sections 1887-1952

Designation	X ₁ ksi	X ₂ x 106 (1/ksi) ²	Elastic Properties						Plastic Modulus	
			Axis x-x			Axis y-y			Z _x	Z _y
			I _x in.4	S _x in.3	r _x in.	I _y in.4	S _y in.3	r _y in.	in.3	in.3
S 5x9.75	4630	334	12.1	4.9	2.05	1.2	0.8	0.65	5.5	1.36
S 5x9.75	4752	314	12.1	4.8	2.05	1.2	0.8	0.65	5.6	1.37
S 5x9.4	4304	468	11.6	4.6	2.05	1.1	0.8	0.64	5.2	1.26
S 5x9.1	4016	523	11.3	4.9	2.06	1.1	0.8	0.65	5.2	1.26
S 4x13.33	9470	24	9.0	4.5	1.54	1.6	1.1	0.65	5.4	1.834
S 4x13.33	9407	25	8.9	4.4	1.53	1.6	1.1	0.65	5.4	1.816
S 4x11.46	8032	44	8.2	4.1	1.56	1.3	0.9	0.63	4.9	1.566
S 4x11.3	8923	33	7.6	3.8	1.51	0.9	0.7	0.52	4.6	1.389
S 4x10.67	8279	46	7.1	3.6	1.51	1.0	0.7	0.57	4.4	1.325
S 4x10.5	8074	49	7.1	3.6	1.52	1.0	0.7	0.57	4.3	1.254
S 4x10.5	7908	53	7.1	3.6	1.52	1.0	0.7	0.57	4.3	1.239
S 4x10.5	7998	54	7.1	3.5	1.52	1.0	0.7	0.57	4.3	1.229
S 4x10.5	8081	50	7.1	3.5	1.52	1.0	0.7	0.57	4.3	1.239
S 4x10.2	6900	70	7.7	3.9	1.42	1.2	0.9	0.55	4.5	1.415
S 4x10	7653	62	6.9	3.4	1.52	1.0	0.7	0.57	4.2	1.187
S 4x10	7849	55	6.9	3.4	1.53	1.0	0.7	0.57	4.2	1.195
S 4x10	6961	66	7.7	3.9	1.62	1.2	0.9	0.65	4.5	1.440
S 4x10	7792	55	6.8	3.4	1.53	0.9	0.7	0.55	4.1	1.157
S 4x9.5	6979	80	6.8	3.4	1.55	0.9	0.7	0.58	4.0	1.147
S 4x9.5	6740	92	6.8	3.4	1.56	0.9	0.7	0.58	4.0	1.123
S 4x9.5	6980	85	6.7	3.3	1.55	0.9	0.7	0.57	4.0	1.129
S 4x9.5	6992	82	6.7	3.3	1.56	0.9	0.7	0.58	4.0	1.131
S 4x9.4	7369	63	6.8	3.4	1.57	0.9	0.7	0.57	4.1	1.154
S 4x9	6420	109	6.5	3.3	1.57	0.9	0.6	0.58	3.8	1.080
S 4x8.5	6055	128	6.4	3.2	1.59	0.9	0.6	0.58	3.7	1.049
S 4x8.5	5909	141	6.4	3.2	1.60	0.9	0.6	0.58	3.7	1.032
S 4x8.5	5840	147	6.3	3.2	1.59	0.8	0.6	0.57	3.7	1.026
S 4x8.5	5894	138	6.3	3.2	1.60	0.8	0.6	0.58	3.7	1.036
S 4x8.4	6644	106	5.8	2.9	1.53	0.5	0.4	0.46	3.5	0.863
S 4x8.3	6108	115	6.4	3.2	1.62	0.8	0.7	0.59	3.8	1.071
S 4x8	7012	93	5.4	2.7	1.50	0.5	0.4	0.43	3.2	0.718
S 4x7.9	5607	168	6.0	3.0	1.72	0.8	0.6	0.58	3.5	0.979
S 4x7.7	5338	188	6.0	3.0	1.64	0.8	0.6	0.59	3.4	0.963
S 4x7.5	5398	188	6.0	3.0	1.63	0.8	0.6	0.59	3.4	0.963
S 4x7.5	5338	188	6.0	3.0	1.64	0.8	0.6	0.59	3.4	0.963
S 4x7.5	5368	182	5.9	3.0	1.64	0.8	0.6	0.58	3.5	0.968
S 4x7.5	5211	213	5.9	3.0	1.63	0.8	0.6	0.58	3.4	0.945
S 4x7.5	5469	176	5.9	2.9	1.63	0.7	0.6	0.56	3.4	0.912
S 4x7	5018	241	5.7	2.9	1.66	0.7	0.6	0.59	3.3	0.910
S 4x6.85	5128	193	5.8	2.9	1.70	0.7	0.6	0.59	3.4	0.916
S 4x6.2	4742	305	4.9	2.5	1.65	0.5	0.4	0.52	2.8	0.692
S 4x6	4909	302	4.6	2.3	1.61	0.4	0.4	0.47	2.7	0.591
S 4x6	4969	288	4.6	2.3	1.61	0.4	0.3	0.45	2.7	0.566
S 3.5x6	5380	182	3.6	2.1	1.43	0.5	0.4	0.51	2.3	0.657
S 3.5x5.8	5304	182	3.6	2.1	1.43	0.5	0.4	0.51	2.3	0.657
S 3x9.07	11675	11	3.4	2.3	1.13	0.6	0.5	0.49	2.8	1.108
S 3x9	11153	11	3.6	2.4	1.17	0.9	0.7	0.57	2.9	1.145
S 3x7.5	9818	22	2.9	1.9	1.15	0.6	0.5	0.52	2.4	0.843
S 3x7.5	9711	23	2.9	1.9	1.15	0.6	0.5	0.52	2.3	0.837
S 3x7.5	9480	26	2.9	1.9	1.14	0.6	0.5	0.52	2.3	0.825
S 3x7.5	9254	28	2.9	1.9	1.14	0.6	0.5	0.52	2.3	0.814
S 3x7.5	9373	26	2.9	1.9	1.15	0.6	0.5	0.52	2.3	0.824
S 3x7	8331	27	3.1	2.1	1.24	0.7	0.6	0.56	2.4	0.905
S 3x7	8755	32	2.8	1.9	1.16	0.5	0.5	0.51	2.3	0.779
S 3x6.93	8860	33	2.7	1.8	1.15	0.4	0.4	0.46	2.2	0.742
S 3x6.83	8112	36	2.9	2.0	1.21	0.6	0.5	0.53	2.3	0.850
S 3x6.8	8657	33	2.8	1.8	1.17	0.5	0.4	0.50	2.2	0.739
S 3x6.5	7796	47	2.7	1.8	1.19	0.5	0.4	0.52	2.1	0.741
S 3x6.5	7716	49	2.7	1.8	1.19	0.5	0.4	0.52	2.1	0.736
S 3x6.5	7512	54	2.7	1.8	1.19	0.5	0.4	0.52	2.1	0.724
S 3x6.5	7361	59	2.6	1.8	1.17	0.5	0.4	0.52	2.1	0.715
S 3x6.5	7468	54	2.7	1.8	1.19	0.5	0.4	0.52	2.1	0.725
S 3x6.3	7840	47	2.5	1.7	1.18	0.4	0.4	0.48	2.0	0.640
S 3x6	7321	56	2.6	1.7	1.21	0.5	0.4	0.51	2.0	0.685
S 3x5.7	6416	89	2.5	1.7	1.22	0.5	0.4	0.52	1.9	0.654
S 3x5.7	6339	89	2.5	1.7	1.23	0.5	0.4	0.53	1.9	0.654
S 3x5.5	6320	89	2.5	1.7	1.23	0.5	0.4	0.53	1.9	0.654
S 3x5.5	6301	89	2.5	1.7	1.23	0.5	0.4	0.53	1.9	0.654
S 3x5.5	6694	78	2.4	1.6	1.23	0.5	0.4	0.53	1.9	0.654
S 3x5.3	6505	81	2.3	1.6	1.22	0.3	0.3	0.47	1.8	0.556
S 3x5.3	6460	83	2.4	1.6	1.24	0.4	0.4	0.51	1.8	0.605
S 3x5.3	6405	89	2.4	1.6	1.23	0.4	0.4	0.51	1.8	0.598
S 3x5.2	6505	81	2.3	1.6	1.22	0.3	0.3	0.47	1.8	0.556
S 3x5.1	6734	74	2.3	1.5	1.23	0.4	0.3	0.47	1.8	0.558

Table 2.3.1 Dimensions and Primary Properties -- Steel Sections 1887-1952

Designation	Source Reference Number	Wt. per ft lb	Area	Depth	Web Thickness	Flange Width	Average Flange Thickness	Distance	Distance	Compact Section Criteria		
			A	d	t _w	b _f	t _f	T	k	b _f /2t _f	h/t _w	F _y ^m
			in.2	in.	in.	in.	in.	in.	in.	in.		
CB362N	10	300.0	88.23	36.72	0.947	16.657	1.680	31.235	2.743	4.96	33.0	59
CB362	11	300.0	88.23	36.85	0.958	16.189	1.716	31.295	2.778	4.72	32.7	60
36WF, CB362	13	300.0	88.17	36.72	0.945	16.655	1.680	31.195	2.763	4.96	33.0	59
36WF, B36a	1	300.0	88.17	36.72	0.945	16.655	1.680	31.647	2.537	4.96	33.5	57
G36	2	300.0	88.12	36.72	0.945	16.655	1.680	30.993	2.864	4.96	32.8	60
G36	2	280.0	82.45	36.50	0.890	16.600	1.570	30.993	2.754	5.29	34.8	53
CB362N	10	280.0	82.34	36.50	0.886	16.596	1.570	31.235	2.633	5.29	35.3	52
36WF, CB362	13	280.0	82.32	36.50	0.885	16.595	1.570	31.195	2.653	5.29	35.2	52
36WF, B36a	1	280.0	82.32	36.50	0.885	16.595	1.570	31.647	2.427	5.29	35.8	50
CB362	11	275.0	80.87	36.55	0.890	16.121	1.565	31.295	2.628	5.15	35.2	52
36WF, CB362	13	260.0	76.56	36.24	0.845	16.555	1.440	31.195	2.523	5.75	36.9	47
36WF, B36a	1	260.0	76.56	36.24	0.845	16.555	1.440	31.647	2.297	5.75	37.5	46
G36	2	260.0	76.50	36.24	0.845	16.555	1.440	30.993	2.624	5.75	36.7	48
CB362N	10	260.0	76.46	36.24	0.843	16.553	1.440	31.235	2.503	5.75	37.1	47
G36	2	250.0	73.61	36.12	0.820	16.530	1.380	30.993	2.564	5.99	37.8	45
CB362N	10	250.0	73.54	36.12	0.817	16.527	1.380	31.235	2.443	5.99	38.2	44
CB362	11	250.0	73.53	36.24	0.824	16.055	1.412	31.295	2.474	5.69	38.0	45
36WF, CB362	12	250.0	73.49	36.12	0.815	16.525	1.380	31.195	2.463	5.99	38.3	44
36WF, B36a	3	250.0	73.49	36.12	0.815	16.525	1.380	31.647	2.237	5.99	38.8	43
36WF, CB362	14	245.0	72.03	36.06	0.802	16.512	1.350	31.195	2.433	6.12	38.9	43
36WF, B36a	4	245.0	72.03	36.06	0.802	16.512	1.350	31.647	2.207	6.12	39.5	41
36WF, CB362	2	240.0	70.60	36.00	0.790	16.500	1.320	31.195	2.403	6.25	39.5	41
36WF, B36a	3	240.0	70.60	36.00	0.790	16.500	1.320	31.647	2.177	6.25	40.1	40
CB362N	10	240.0	70.58	36.00	0.790	16.500	1.320	31.235	2.383	6.25	39.5	41
G36	2	240.0	70.55	36.00	0.790	16.500	1.320	30.993	2.504	6.25	39.2	42
G36	5	231.0	67.85	35.88	0.770	16.480	1.260	30.993	2.444	6.54	40.3	40
36WF, CB362	13	230.0	67.73	35.88	0.765	16.475	1.260	31.195	2.343	6.54	40.8	39
36 WF, B36a	1	230.0	67.73	35.88	0.765	16.475	1.260	31.647	2.117	6.54	41.4	38
G36	8	230.0	67.67	35.88	0.765	16.475	1.260	30.993	2.444	6.54	40.5	39
CB362	11	230.0	67.65	36.00	0.769	16.000	1.290	31.295	2.353	6.20	40.7	39
CB362N	10	230.0	67.63	35.88	0.763	16.473	1.260	31.235	2.323	6.54	40.9	38
36WF, CB361	13	194.0	57.11	36.48	0.770	12.117	1.260	32.235	2.123	4.81	41.9	37
36WF, B36	1	194.0	57.11	36.48	0.770	12.117	1.260	32.581	1.950	4.81	42.3	36
CB361	11	192.0	56.47	36.65	0.740	12.150	1.257	32.006	2.320	4.83	43.3	34
B36	9	192.0	56.46	36.50	0.745	12.110	1.270	32.107	2.197	4.77	43.1	35
CB361N	10	192.0	56.45	36.50	0.744	12.109	1.270	32.235	2.133	4.77	43.3	34
B36	7	190.0	55.87	36.52	0.726	12.111	1.272	32.123	2.199	4.76	44.2	33
36WF, CB361	13	182.0	53.54	36.32	0.725	12.072	1.180	32.235	2.043	5.12	44.5	33
36WF, B36	1	182.0	53.54	36.32	0.725	12.072	1.180	32.581	1.870	5.12	44.9	32
B36	9	176.0	51.80	36.25	0.700	12.065	1.145	32.107	2.072	5.27	45.9	31
CB361N	10	176.0	51.76	36.25	0.698	12.063	1.145	32.235	2.008	5.27	46.2	30
CB361	11	175.0	51.47	36.40	0.686	12.096	1.132	32.006	2.195	5.34	46.7	30
B36	6	173.0	50.94	36.25	0.680	12.065	1.137	32.123	2.064	5.31	47.2	29
36WF, CB361	13	170.0	49.98	36.16	0.680	12.027	1.100	32.235	1.963	5.47	47.4	29
36WF, B36	1	170.0	49.98	36.16	0.680	12.027	1.100	32.581	1.790	5.47	47.9	28
B36	9	167.0	49.15	36.12	0.670	12.035	1.080	32.107	2.007	5.57	47.9	28
CB361N	10	167.0	49.10	36.12	0.668	12.033	1.080	32.235	1.943	5.57	48.3	28
B36	6	164.0	48.10	36.12	0.645	12.030	1.072	32.123	1.999	5.61	49.8	26
36WF, CB361	13	160.0	47.09	36.00	0.653	12.000	1.020	32.235	1.883	5.88	49.4	26
36WF, B36	1	160.0	47.09	36.00	0.653	12.000	1.020	32.581	1.710	5.88	49.9	26
CB361	11	160.0	47.06	36.18	0.635	12.045	1.026	32.006	2.089	5.87	50.4	25
CB361N	10	158.0	46.47	36.00	0.635	12.000	1.020	32.235	1.883	5.88	50.8	25
B36	9	158.0	46.44	36.00	0.635	12.000	1.020	32.107	1.947	5.88	50.6	25
B36	6	155.0	45.58	36.00	0.615	12.000	1.012	32.123	1.939	5.93	52.2	24
36WF, B36	1	150.0	44.16	35.84	0.625	11.972	0.940	32.581	1.630	6.37	52.1	24
36WF, CB361	13	150.0	44.16	35.84	0.625	11.972	0.940	32.235	1.803	6.37	51.6	24
CB361N	10	150.0	44.10	35.88	0.609	11.974	0.960	32.235	1.823	6.24	52.9	23
B36	9	150.0	44.10	35.88	0.610	11.975	0.960	32.107	1.887	6.24	52.6	23
B36	5	147.0	43.24	35.88	0.590	11.975	0.952	32.123	1.879	6.29	54.4	22
CB361N	11	147.0	43.23	36.00	0.590	12.000	0.935	32.006	1.997	6.42	54.2	22
B36	7	147.0	43.23	35.90	0.583	11.968	0.962	32.123	1.889	6.22	55.1	21
G33	1	260.0	76.54	33.63	0.875	15.890	1.550	28.274	2.678	5.13	32.3	62
CB332	8	260.0	76.47	33.79	0.870	16.150	1.519	28.624	2.581	5.32	32.9	59
CB332N	9	260.0	76.46	33.75	0.893	15.923	1.525	28.875	2.438	5.22	32.3	62
G33	2	260.0	76.45	33.75	0.890	15.920	1.525	28.444	2.653	5.22	32.0	63
G33	1	245.0	72.19	33.44	0.835	15.850	1.455	28.274	2.583	5.45	33.9	56
G33	2	240.0	70.63	33.50	0.835	15.865	1.400	28.444	2.528	5.67	34.1	55
CB332	8	240.0	70.58	33.55	0.810	16.090	1.399	28.624	2.461	5.75	35.3	52
CB332N	9	240.0	70.57	33.50	0.836	15.866	1.400	28.875	2.313	5.67	34.5	54
33WF	4	240.0	70.52	33.50	0.830	15.865	1.400	29.070	2.215	5.67	35.0	52
33WF	11	240.0	70.52	33.50	0.830	15.865	1.400	28.655	2.423	5.67	34.5	54
G33	3	230.0	67.85	33.25	0.795	15.810	1.360	28.274	2.488	5.81	35.6	51
G33	2	220.0	64.83	33.25	0.780	15.810	1.275	28.444	2.403	6.20	36.5	48
G33	3	220.0	64.80	33.12	0.765	15.780	1.295	28.274	2.423	6.09	37.0	47

Table 2.3.1 Dimensions and Primary Properties – Steel Sections 1887-1952

Designation	X ₁ ksi	X ₂ x 106 (1/ksi) ²	Elastic Properties						Plastic Modulus	
			Axis x-x			Axis y-y			Z _x in.3	Z _y in.3
			I _x	S _x	r _x	I _y	S _y	r _y		
			in.4	in.3	in.	in.4	in.3	in.		
CB362N	2734	2864	20303.4	1105.8	15.17	1296.7	155.7	3.83	1244.0	240.5
CB362	2788	2681	20317.7	1102.7	15.18	1215.9	150.2	3.71	1243.3	232.5
36WF, CB362	2737	2854	20290.2	1105.1	15.17	1225.2	147.1	3.73	1243.4	240.5
36WF, B36a	2780	2678	20290.2	1105.1	15.17	1225.2	147.1	3.73	1243.4	240.5
G36	2858	2403	20262.0	1103.6	15.16	1177.7	141.4	3.66	1242.8	227.0
G36	2690	3054	18811.0	1030.8	15.10	1081.4	130.3	3.62	1157.4	209.5
CB362N	2562	3696	18828.3	1031.7	15.12	1198.3	144.4	3.81	1156.6	222.8
36WF, CB362	2565	3678	18819.3	1031.2	15.12	1127.5	135.9	3.70	1156.3	222.7
36WF, B36a	2611	3426	18819.3	1031.2	15.12	1127.5	135.9	3.70	1156.3	222.7
CB362	2565	3736	18400.2	1006.8	15.08	1095.1	135.9	3.68	1131.2	210.0
36WF, CB362	2389	4931	17233.8	951.1	15.00	1020.6	123.3	3.65	1064.7	203.3
36WF, B36a	2439	4539	17233.8	951.1	15.00	1020.6	123.3	3.65	1064.7	203.3
G36	2510	4058	17205.0	949.5	15.00	973.7	117.6	3.57	1064.1	189.8
CB362N	2383	4972	17230.8	950.9	15.01	1090.5	131.8	3.78	1064.0	203.2
G36	2423	4678	16457.0	911.2	14.95	923.8	111.8	3.54	1020.1	180.7
CB362N	2296	5782	16478.7	912.4	14.97	1040.1	125.9	3.76	1019.6	194.0
CB362	2341	5396	16499.3	910.5	14.98	975.4	121.5	3.64	1019.4	187.6
36WF, CB362	2298	5757	16465.9	911.7	14.97	969.6	117.4	3.63	1019.0	194.0
36WF, B36a	2350	5267	16465.9	911.7	14.97	969.6	117.4	3.63	1019.0	194.0
36WF, CB362	2254	6222	16092.2	892.5	14.95	944.7	114.4	3.62	996.9	189.4
36WF, B36a	2307	5674	16092.2	892.5	14.95	944.7	114.4	3.62	996.9	189.4
36WF, CB362	2211	6728	15724.0	873.6	14.92	920.1	111.5	3.61	975.1	184.9
36WF, B36a	2265	6115	15724.0	873.6	14.92	920.1	111.5	3.61	975.1	184.9
CB362N	2207	6774	15729.0	873.8	14.93	989.9	120.0	3.74	975.1	184.9
G36	2332	5452	15696.0	872.0	14.92	873.5	105.9	3.52	974.6	171.4
G36	2250	6318	14979.0	835.0	14.86	825.3	100.2	3.49	932.5	162.6
36WF, CB362	2125	7912	14988.4	835.5	14.88	870.9	105.7	3.59	931.5	175.9
36 WF, B36a	2180	7136	14988.4	835.5	14.88	870.9	105.7	3.59	931.5	175.9
G36	2246	6354	14960.0	833.9	14.87	824.5	100.1	3.49	930.9	162.4
CB362	2161	7438	15012.9	834.0	14.90	882.2	110.3	3.61	931.1	170.1
CB362N	2118	7989	14985.6	835.3	14.89	940.2	114.2	3.73	930.9	175.8
36WF, CB361	2162	8610	12103.4	663.6	14.56	355.4	58.7	2.49	759.7	97.5
36WF, B36	2196	8094	12103.4	663.6	14.56	355.4	58.7	2.49	759.7	97.5
CB361	2146	8687	12208.5	666.3	14.70	377.2	62.1	2.58	756.0	97.5
B36	2228	7504	12082.0	662.0	14.63	344.4	56.9	2.47	756.4	92.7
CB361N	2142	8765	12096.6	662.8	14.64	377.1	62.3	2.59	756.3	97.8
B36	2207	7681	12049.0	659.9	14.68	344.9	57.0	2.48	752.3	92.6
36WF, CB361	2034	10977	11281.5	621.2	14.52	327.7	54.3	2.47	709.6	90.4
36WF, B36	2069	10249	11281.5	621.2	14.52	327.7	54.3	2.47	709.6	90.4
B36	2054	10508	10902.0	601.5	14.51	303.7	50.3	2.42	686.6	82.4
CB361N	1968	12435	10912.6	602.1	14.52	336.1	55.7	2.55	686.1	87.4
CB361	1965	12429	10978.8	603.3	14.61	335.0	55.4	2.55	682.6	86.8
B36	2023	11059	10784.0	595.0	14.55	301.1	49.9	2.43	677.7	81.6
36WF, CB361	1905	14231	10470.0	579.1	14.47	300.6	50.0	2.45	659.9	83.5
36WF, B36	1942	13179	10470.0	579.1	14.47	300.6	50.0	2.45	659.9	83.5
B36	1957	12798	10271.0	568.7	14.46	282.3	46.9	2.40	648.4	76.9
CB361N	1871	15262	10281.5	569.3	14.47	314.6	52.3	2.53	648.0	82.0
B36	1919	13621	10133.0	561.1	14.51	279.4	46.5	2.41	637.9	76.0
36WF, CB361	1798	18147	9738.8	541.0	14.38	275.4	45.9	2.42	616.4	77.1
36WF, B36	1838	16641	9738.8	541.0	14.38	275.4	45.9	2.42	616.4	77.1
CB361	1806	17466	9933.2	549.1	14.53	299.8	49.8	2.52	619.4	77.9
CB361N	1776	18812	9683.8	538.0	14.44	294.6	49.1	2.52	611.2	76.9
B36	1859	15695	9665.2	537.0	14.43	262.4	43.7	2.38	611.0	71.8
B36	1827	16608	9547.4	530.4	14.47	259.9	43.3	2.39	602.2	71.0
36WF, B36	1733	21320	9012.1	502.9	14.29	250.4	41.8	2.38	573.0	70.7
36WF, CB361	1691	23517	9012.1	502.9	14.29	250.4	41.8	2.38	573.0	70.7
CB361N	1688	23128	9118.7	508.3	14.38	275.4	46.0	2.50	577.0	72.0
B36	1773	19085	9104.0	507.5	14.37	243.4	40.7	2.35	577.1	66.9
B36	1741	20268	8986.2	500.9	14.42	240.9	40.2	2.36	568.2	66.1
CB361N	1669	24041	9040.4	502.2	14.46	269.9	45.0	2.50	565.1	70.3
B36	1743	19995	9036.3	503.4	14.46	243.3	40.7	2.37	570.3	66.7
G33	2879	2298	14868.0	884.2	13.94	939.8	118.3	3.50	993.5	189.8
CB332	2691	3002	15037.7	890.2	14.02	1068.0	132.3	3.74	997.0	203.8
CB332N	2707	2977	14881.7	881.9	13.95	1028.1	129.1	3.67	992.9	199.4
G33	2849	2428	14872.0	881.3	13.95	928.5	116.6	3.48	991.6	187.5
G33	2729	2852	13895.0	831.0	13.87	869.2	109.7	3.47	931.7	176.3
G33	2650	3248	13575.0	810.5	13.86	835.0	105.3	3.44	909.2	169.8
CB332	2494	4057	13750.6	819.8	13.96	972.5	120.9	3.71	914.8	186.1
CB332N	2507	4052	13578.0	810.6	13.87	933.6	117.7	3.64	910.0	181.6
33WF	2571	3652	13585.1	811.1	13.88	874.3	110.2	3.52	908.5	181.5
33WF	2518	3968	13585.1	811.1	13.88	874.3	110.2	3.52	908.5	181.5
G33	2578	3584	12935.0	778.0	13.81	799.6	101.2	3.43	870.4	163.0
G33	2452	4445	12302.0	740.0	13.78	743.4	94.0	3.39	827.8	152.2
G33	2473	4235	12278.0	741.4	13.77	752.2	95.3	3.41	828.1	153.9

Table 2.3.1 Dimensions and Primary Properties -- Steel Sections 1887-1952

Designation	Source Reference Number	Wt. per ft. lb	Area	Depth	Web Thickness	Flange Width	Average Flange Thickness	Distance	Distance	Compact Section Criteria		
			A	d	t_w	b_f	t_f	T	k	$b/2t_f$	h/t_w	F_y "
			in.2	in.	in.	in.	in.	in.	in.			ksi
33WF, CB332	11	220.0	64.73	33.25	0.775	15.810	1.275	28.655	2.298	6.20	37.0	47
33WF	4	220.0	64.73	33.25	0.775	15.810	1.275	29.070	2.090	6.20	37.5	46
CB332	8	220.0	64.70	33.27	0.766	16.046	1.262	28.624	2.324	6.36	37.4	46
CB332N	9	220.0	64.68	33.25	0.778	15.808	1.275	28.875	2.188	6.20	37.1	47
G33	3	210.0	61.91	33.00	0.735	15.750	1.235	28.274	2.363	6.38	38.5	44
33WF	5	210.0	61.78	33.12	0.748	15.783	1.210	29.070	2.025	6.52	38.9	43
33WF	10	210.0	61.78	33.12	0.748	15.783	1.210	28.655	2.233	6.52	38.3	44
G33	2	210.0	61.78	33.12	0.750	15.780	1.210	28.444	2.338	6.52	37.9	45
CB332N	9	210.0	61.76	33.12	0.752	15.782	1.210	28.875	2.123	6.52	38.4	44
G33	6	202.0	59.53	32.88	0.720	15.735	1.175	28.274	2.303	6.70	39.3	42
G33	2	200.0	58.90	33.00	0.720	15.750	1.150	28.444	2.278	6.85	39.5	41
G33	1	200.0	58.87	32.88	0.700	15.715	1.175	28.274	2.303	6.69	40.4	39
CB332	8	200.0	58.82	33.00	0.720	16.000	1.126	28.624	2.188	7.11	39.8	41
CB332N	9	200.0	58.81	33.00	0.720	15.750	1.150	28.875	2.063	6.85	40.1	40
33WF, CB332	11	200.0	58.79	33.00	0.715	15.750	1.150	28.655	2.173	6.85	40.1	40
33WF	4	200.0	58.79	33.00	0.715	15.750	1.150	29.070	1.965	6.85	40.7	39
CB331	8	167.0	49.12	33.53	0.719	12.179	1.062	29.281	2.125	5.73	40.7	39
B33	1	165.0	48.52	33.50	0.680	11.350	1.190	29.381	2.060	4.77	43.2	34
33WF, CB331	11	152.0	44.71	33.50	0.635	11.565	1.055	29.765	1.868	5.48	46.9	29
33WF, B33	4	152.0	44.71	33.50	0.635	11.565	1.055	30.095	1.703	5.48	47.4	29
CB331N	9	152.0	44.69	33.50	0.636	11.566	1.055	29.865	1.818	5.48	47.0	29
CB331	8	152.0	44.69	33.34	0.655	12.115	0.968	29.281	2.031	6.26	44.7	32
B33	6	152.0	44.69	33.25	0.650	11.320	1.065	29.381	1.935	5.31	45.2	32
B33	2	152.0	44.68	33.50	0.635	11.565	1.055	29.639	1.931	5.48	46.7	30
B33	1	152.0	44.65	33.27	0.642	11.312	1.075	29.381	1.945	5.26	45.8	31
B33	3	143.0	42.05	33.12	0.615	11.285	1.000	29.381	1.870	5.64	47.8	28
33WF	4	141.0	41.51	33.31	0.605	11.535	0.960	30.095	1.608	6.01	49.7	26
33WF, CB331	11	141.0	41.51	33.31	0.605	11.535	0.960	29.765	1.773	6.01	49.2	27
B33	2	141.0	41.48	33.31	0.605	11.535	0.960	29.639	1.836	6.01	49.0	27
CB331N	9	141.0	41.46	33.31	0.605	11.535	0.960	29.865	1.723	6.01	49.4	26
CB331	8	138.0	40.58	33.16	0.596	12.056	0.879	29.281	1.942	6.86	49.1	27
B33	3	135.0	39.55	33.00	0.580	11.250	0.940	29.381	1.810	5.98	50.7	25
33WF	5	132.0	38.84	33.15	0.580	11.510	0.880	30.095	1.528	6.54	51.9	24
33WF	10	132.0	38.84	33.15	0.580	11.510	0.880	29.765	1.693	6.54	51.3	24
CB33N	9	132.0	38.82	33.15	0.581	11.511	0.880	29.865	1.643	6.54	51.4	24
B33	2	132.0	38.81	33.15	0.580	11.510	0.880	29.639	1.756	6.54	51.1	25
33WF	12	130.0	38.26	33.10	0.580	11.510	0.855	29.765	1.668	6.73	51.3	24
33WF, B33	7	130.0	38.26	33.10	0.580	11.510	0.855	30.095	1.503	6.73	51.9	24
B33	6	125.0	36.88	32.88	0.540	11.210	0.880	29.381	1.750	6.37	54.4	22
B33	1	125.0	36.83	32.89	0.535	11.205	0.885	29.381	1.755	6.33	54.9	21
33WF, B33	5	125.0	36.78	33.00	0.570	11.500	0.805	30.095	1.453	7.14	52.8	23
33WF, CB331	10	125.0	36.78	33.00	0.570	11.500	0.805	29.765	1.618	7.14	52.2	24
CB331	8	125.0	36.75	33.00	0.540	12.000	0.797	29.281	1.860	7.53	54.2	22
B33	2	125.0	36.75	33.00	0.570	11.500	0.805	29.639	1.681	7.14	52.0	24
CB331N	9	125.0	36.73	33.00	0.570	11.500	0.805	29.865	1.568	7.14	52.4	23
G30	1	240.0	70.60	30.75	0.880	15.200	1.503	25.602	2.574	5.06	29.1	-
CB302N	16	240.0	70.58	30.75	0.882	15.207	1.500	25.925	2.413	5.07	29.4	-
CB302N	13	240.0	70.58	30.78	0.888	14.218	1.597	25.462	2.660	4.45	28.7	-
G30	2	240.0	70.54	30.75	0.880	15.205	1.500	25.608	2.571	5.07	29.1	-
G30	1	220.0	64.82	30.50	0.815	15.135	1.378	25.602	2.449	5.49	31.4	-
G30	2	220.0	64.76	30.50	0.815	15.140	1.375	25.608	2.446	5.51	31.4	-
CB302N	16	220.0	64.70	30.50	0.814	15.139	1.375	25.925	2.288	5.51	31.8	63
CB302N	13	220.0	64.70	30.52	0.816	14.146	1.468	25.462	2.530	4.82	31.2	-
30WF	4	210.0	61.78	30.38	0.775	15.105	1.315	26.204	2.088	5.74	33.8	56
30WF	18	210.0	61.78	30.38	0.775	15.105	1.315	25.805	2.288	5.74	33.3	58
G30	3	200.0	58.92	30.25	0.745	15.065	1.253	25.602	2.324	6.01	34.4	55
G30	2	200.0	58.86	30.25	0.745	15.070	1.250	25.608	2.321	6.03	34.4	54
G30	5	200.0	58.85	30.00	0.750	15.000	1.276	24.928	2.536	5.88	33.2	58
CB302N	16	200.0	58.83	30.25	0.745	15.070	1.250	25.925	2.163	6.03	34.8	53
CB302N	13	200.0	58.82	30.26	0.743	14.073	1.338	25.462	2.401	5.26	34.3	55
30WF, CB302	17	200.0	58.76	30.25	0.740	15.070	1.250	25.805	2.223	6.03	34.9	53
30WF	6	200.0	58.76	30.25	0.740	15.070	1.250	26.204	2.023	6.03	35.4	51
G30	7	200.0	58.71	30.00	0.750	15.000	1.271	25.188	2.406	5.90	33.6	57
G30	8	200.0	58.52	30.13	0.760	15.040	1.248	25.489	2.318	6.03	33.5	57
30WF, B30a	18	190.0	55.90	30.12	0.710	15.040	1.185	26.204	1.958	6.35	36.9	47
30WF, CB302	18	190.0	55.90	30.12	0.710	15.040	1.185	25.805	2.158	6.35	36.3	49
G30	3	190.0	55.90	30.12	0.710	15.030	1.188	25.602	2.259	6.33	36.1	50
CB302N	16	190.0	55.88	30.12	0.712	15.037	1.185	25.925	2.098	6.34	36.4	49
G30	2	190.0	55.84	30.12	0.710	15.035	1.185	25.608	2.256	6.34	36.1	49
G30	8	190.0	55.52	30.00	0.720	15.000	1.188	25.484	2.258	6.32	35.4	51
G30	8	181.0	52.82	29.88	0.690	14.970	1.128	25.479	2.198	6.64	36.9	47
G30	3	180.0	53.20	30.00	0.680	15.000	1.128	25.602	2.199	6.65	37.6	45
G30	7	180.0	53.00	30.00	0.690	13.000	1.312	25.192	2.404	4.95	36.5	48
G30	2	180.0	52.99	30.00	0.675	15.000	1.125	25.608	2.196	6.67	37.9	45
CB302N	16	180.0	52.96	30.00	0.675	15.000	1.125	25.925	2.038	6.67	38.4	44

Table 2.3.1 Dimensions and Primary Properties – Steel Sections 1887-1952

Designation	X ₁ ksi	X ₂ x 106 (1/ksi) ²	Elastic Properties						Plastic Modulus	
			Axis x-x			Axis y-y			Z _x	Z _y
			I _x in.4	S _x in.3	r _x in.	I _y in.4	S _y in.3	r _y in.	in.3	in.3
33WF, CB332	2320	5523	12312.1	740.6	13.79	782.4	99.0	3.48	827.2	164.0
33WF	2377	5014	12312.1	740.6	13.79	782.4	99.0	3.48	827.2	164.0
CB332	2292	5745	12385.5	744.5	13.84	870.0	108.4	3.67	829.0	166.9
CB332N	2305	5672	12295.7	739.6	13.79	840.8	106.4	3.61	827.8	164.0
G33	2374	4985	11671.0	707.3	13.73	708.5	90.0	3.38	788.6	145.5
33WF	2278	5961	11664.5	704.4	13.74	735.6	93.2	3.45	785.6	155.0
33WF	2218	6623	11664.5	704.4	13.74	735.6	93.2	3.45	785.6	155.0
G33	2348	5292	11645.0	703.2	13.73	696.2	88.2	3.36	785.5	143.2
CB332N	2204	6804	11651.2	703.6	13.74	794.0	100.6	3.59	786.5	155.0
G33	2290	5803	11114.0	676.0	13.66	667.3	84.8	3.35	753.5	137.7
G33	2250	6280	11038.0	669.0	13.69	652.9	82.9	3.33	746.0	134.8
G33	2270	5941	11055.0	672.4	13.70	664.6	84.6	3.36	748.1	137.1
CB332	2091	8390	11049.6	669.7	13.71	769.5	96.2	3.62	744.2	148.0
CB332N	2104	8197	11037.9	669.0	13.70	749.9	95.2	3.57	746.5	146.6
33WF, CB332	2117	7977	11048.2	669.6	13.71	691.7	87.8	3.43	745.4	146.6
33WF	2178	7116	11048.2	669.6	13.71	691.7	87.8	3.43	745.4	146.6
CB331	2085	9923	8836.1	527.1	13.41	321.0	52.7	2.56	597.2	82.8
B33	2250	7054	8835.4	527.5	13.49	265.5	46.8	2.34	600.9	76.0
33WF, CB331	1943	12769	8147.6	486.4	13.50	256.1	44.3	2.39	552.3	73.7
33WF, B33	1980	11843	8147.6	486.4	13.50	256.1	44.3	2.39	552.3	73.7
CB331N	1936	12970	8143.0	486.2	13.50	272.8	47.2	2.47	552.6	73.7
CB331	1910	13985	7998.5	479.8	13.38	287.8	47.5	2.54	541.2	74.4
B33	2079	9910	7953.4	478.4	13.34	233.0	41.2	2.28	545.2	67.3
B33	2030	10739	8136.2	485.7	13.49	245.1	42.4	2.34	552.1	69.2
B33	2080	9800	7991.4	480.4	13.38	234.9	41.5	2.29	546.8	67.8
B33	1967	12366	7442.2	449.4	13.30	215.1	38.1	2.26	511.2	62.4
33WF	1848	15869	7442.2	446.8	13.39	229.7	39.8	2.35	507.3	66.7
33WF, CB331	1808	17326	7442.2	446.8	13.39	229.7	39.8	2.35	507.3	66.7
B33	1894	14404	7430.8	446.2	13.38	218.7	37.9	2.30	507.1	62.2
CB331N	1799	17659	7434.5	446.4	13.39	246.2	42.7	2.44	507.3	66.7
CB331	1748	19852	7223.0	435.6	13.34	257.5	42.7	2.52	489.1	66.7
B33	1860	15424	6967.4	422.3	13.27	198.7	35.3	2.24	479.3	57.9
33WF	1738	20593	6856.8	413.7	13.29	207.8	36.1	2.31	469.7	60.9
33WF	1695	22770	6856.8	413.7	13.29	207.8	36.1	2.31	469.7	60.9
CB33N	1688	23187	6852.1	413.4	13.29	224.3	39.0	2.40	470.0	61.0
B33	1782	18696	6845.4	413.0	13.28	196.8	34.2	2.25	469.5	56.4
33WF	1671	24414	6699.0	404.8	13.23	201.4	35.0	2.29	460.2	59.3
33WF, B33	1715	21989	6699.0	404.8	13.23	201.4	35.0	2.29	460.2	59.3
B33	1748	19667	6482.7	394.3	13.26	182.3	32.5	2.22	446.2	53.3
B33	1747	19573	6498.2	395.1	13.28	183.2	32.7	2.23	446.7	53.6
33WF, B33	1657	25686	6354.7	385.1	13.14	188.2	32.7	2.26	438.5	55.8
33WF, CB331	1611	28780	6354.7	385.1	13.14	188.2	32.7	2.26	438.5	55.8
CB331	1597	28316	6514.3	394.8	13.31	230.1	38.4	2.50	441.1	59.7
B33	1697	23388	6343.3	384.4	13.14	177.2	30.8	2.20	438.3	51.2
CB331N	1601	29439	6347.0	384.7	13.14	204.6	35.6	2.36	438.5	55.8
G30	3086	1745	11423.0	742.9	12.72	779.2	105.2	3.36	836.9	168.7
CB302N	2937	2124	11427.6	743.3	12.72	880.9	115.9	3.53	837.0	178.8
CB302N	3138	1647	11356.0	737.9	12.69	766.9	107.9	3.30	831.6	166.9
G30	3082	1755	11412.0	742.3	12.72	798.5	105.0	3.36	836.1	168.6
G30	2856	2369	10378.0	680.5	12.65	716.1	94.6	3.32	763.6	152.2
G30	2852	2383	10367.0	679.8	12.65	715.3	94.5	3.32	762.8	152.0
CB302N	2705	2935	10375.4	680.4	12.66	796.6	105.2	3.51	763.0	162.2
CB302N	2894	2257	10320.4	676.3	12.63	693.9	98.1	3.28	758.4	151.4
30WF	2654	3152	9872.4	649.9	12.64	707.9	93.7	3.38	726.5	154.2
30WF	2599	3429	9872.4	649.9	12.64	707.9	93.7	3.38	726.5	154.2
G30	2621	3319	9343.8	617.8	12.59	634.2	84.2	3.28	690.1	135.8
G30	2617	3339	9332.7	617.0	12.59	633.4	84.1	3.28	689.3	135.6
G30	2803	2544	9154.7	610.3	12.47	599.7	80.0	3.19	689.9	132.3
CB302N	2472	4185	9343.2	617.7	12.60	714.1	94.8	3.48	689.7	145.8
CB302N	2648	3188	9305.7	615.0	12.58	622.7	88.5	3.25	686.0	136.3
30WF, CB302	2478	4136	9340.5	617.6	12.61	665.7	88.3	3.37	688.7	145.7
30WF	2535	3775	9340.5	617.6	12.61	665.7	88.3	3.37	688.7	145.7
G30	2714	2885	9150.6	610.0	12.48	630.2	84.0	3.28	688.4	135.9
G30	2656	3184	9148.8	607.5	12.50	628.5	83.6	3.28	686.4	135.0
30WF, B30a	2422	4532	8825.9	586.1	12.57	624.6	83.1	3.34	652.4	137.5
30WF, CB302	2363	5005	8825.9	586.1	12.57	624.6	83.1	3.34	652.4	137.5
G30	2501	3995	8818.0	585.5	12.56	592.7	78.9	3.26	652.6	127.4
CB302N	2353	5089	8821.8	585.8	12.56	672.5	89.4	3.47	652.7	137.5
G30	2497	4023	8806.7	584.8	12.56	591.9	78.7	3.26	651.8	127.2
G30	2537	3804	8651.1	576.7	12.48	589.4	78.6	3.26	650.2	127.1
G30	2428	4530	8181.0	547.6	12.45	552.0	73.7	3.23	616.4	119.5
G30	2393	4767	8343.1	556.2	12.52	555.1	74.0	3.23	618.7	119.8
G30	2736	2833	8194.5	546.3	12.43	433.3	66.7	2.86	618.3	107.1
G30	2383	4829	8320.4	554.7	12.53	553.7	73.8	3.23	616.8	119.5
CB302N	2237	6201	8331.0	555.4	12.54	633.7	84.5	3.46	617.2	129.7

Table 2.3.1 Dimensions and Primary Properties -- Steel Sections 1887-1952

Designation	Source Reference Number	Wt. per ft lb	Area	Depth	Web Thickness	Flange Width	Average Flange Thickness	Distance	Distance	Compact Section Criteria		
			A	d	t _w	b _f	t _f	T	k	b _f /2t _f	h/t _w	F _y ^m
			in.2	in.	in.	in.	in.	in.	in.	in.		
CB302N	13	180.0	52.93	30.00	0.670	14.000	1.207	25.462	2.269	5.80	38.0	45
30WF, CB302	17	180.0	52.89	30.00	0.670	15.000	1.125	25.805	2.098	6.67	38.5	43
30WF, CB302	6	180.0	52.89	30.00	0.670	15.000	1.125	26.204	1.898	6.67	39.1	42
G30	5	175.0	51.35	30.00	0.680	12.000	1.367	24.928	2.536	4.39	36.7	48
G30	9	173.0	50.94	29.75	0.675	14.955	1.063	25.484	2.133	7.04	37.8	45
G30	3	173.0	50.80	29.88	0.660	14.980	1.068	25.602	2.139	7.02	38.8	43
30WF, B30a	4	172.0	50.65	29.88	0.655	14.985	1.065	26.204	1.838	7.04	40.0	40
30WF, CB302	18	172.0	50.65	29.88	0.655	14.985	1.065	25.805	2.038	7.04	39.4	41
CB301	15	165.0	48.52	30.74	0.755	10.725	1.253	26.711	2.016	4.28	35.4	51
B30	1	163.0	48.00	30.65	0.730	10.680	1.273	26.478	2.086	4.20	36.3	49
CB301	15	151.0	44.41	30.54	0.692	10.662	1.151	26.711	1.914	4.63	38.6	43
B30	1	149.0	43.93	30.44	0.670	10.620	1.168	26.478	1.981	4.55	39.5	41
CB301	15	138.0	40.58	30.34	0.634	10.604	1.054	26.711	1.817	5.03	42.1	36
B30	1	137.0	40.40	30.25	0.620	10.570	1.073	26.478	1.886	4.93	42.7	35
CB301	13	135.0	39.70	30.30	0.621	10.591	1.031	26.711	1.794	5.14	43.0	35
30WF, B30	4	132.0	38.83	30.30	0.615	10.551	1.000	27.088	1.606	5.28	44.0	33
30WF, CB301	18	132.0	38.83	30.30	0.615	10.551	1.000	26.775	1.763	5.28	43.5	34
CB302N	16	131.0	38.52	30.31	0.602	10.547	1.005	26.875	1.718	5.25	44.6	32
B30	2	131.0	38.47	30.31	0.600	10.545	1.005	26.674	1.818	5.25	44.5	33
B30	3	129.0	37.82	30.12	0.580	10.530	1.008	26.478	1.821	5.23	45.7	31
B30	10	129.0	37.52	30.13	0.580	10.530	1.008	26.483	1.821	5.23	45.7	31
CB301	15	126.0	37.05	30.16	0.581	10.551	0.963	26.711	1.726	5.48	46.0	30
CB301	13	125.0	36.75	30.15	0.576	10.546	0.956	26.711	1.719	5.52	46.4	30
30WF, B30	4	124.0	36.45	30.16	0.585	10.521	0.930	27.088	1.536	5.66	46.3	30
30WF, CB301	18	124.0	36.45	30.16	0.585	10.521	0.930	26.775	1.693	5.66	45.8	31
B30	2	122.0	35.87	30.12	0.580	10.525	0.910	26.674	1.723	5.78	46.0	30
CB301N	16	122.0	35.85	30.12	0.580	10.525	0.910	26.875	1.623	5.78	46.3	30
B30	3	121.0	35.65	30.00	0.550	10.500	0.948	26.478	1.761	5.54	48.1	28
B30	10	121.0	35.36	30.00	0.550	10.500	0.948	26.478	1.761	5.54	48.1	28
B30	11	121.0	35.30	30.00	0.540	10.500	0.959	26.422	1.789	5.47	48.9	27
B30	7	120.0	35.30	30.00	0.540	10.500	0.959	26.422	1.789	5.47	48.9	27
B30	5	120.0	35.25	30.00	0.520	10.000	1.037	26.172	1.914	4.82	50.3	25
30WF, B30	4	116.0	34.13	30.00	0.564	10.500	0.850	27.088	1.456	6.18	48.0	28
30WF, CB301	18	116.0	34.13	30.00	0.564	10.500	0.850	26.775	1.613	6.18	47.5	29
B30	2	115.0	33.85	30.00	0.555	10.500	0.850	26.674	1.663	6.18	48.1	28
CB301N	16	115.0	33.84	30.00	0.555	10.500	0.850	26.875	1.563	6.18	48.4	27
CB301	14	115.0	33.81	30.00	0.530	10.500	0.882	26.711	1.645	5.95	50.4	25
B30	3	115.0	33.80	29.88	0.530	10.480	0.888	26.478	1.701	5.90	50.0	26
B30	10	115.0	33.50	29.88	0.530	10.480	0.888	26.478	1.701	5.90	50.0	26
B30	12	110.0	32.45	29.78	0.520	10.470	0.838	26.478	1.651	6.25	50.9	25
B30	2	108.0	31.85	29.88	0.530	10.475	0.790	26.674	1.603	6.63	50.3	25
CB301N	16	108.0	31.77	29.88	0.528	10.473	0.790	26.875	1.503	6.63	50.9	25
30WF	4	108.0	31.77	29.82	0.548	10.484	0.760	27.088	1.366	6.90	49.4	26
30WF, CB301	18	108.0	31.77	29.82	0.548	10.484	0.760	26.775	1.523	6.90	48.9	27
G28	1	186.0	54.73	28.31	0.730	14.305	1.238	23.805	2.252	5.78	32.6	61
G28a	2	180.0	52.98	28.00	0.690	14.350	1.232	23.153	2.424	5.82	33.6	57
G28a	3	180.0	52.86	28.00	0.690	14.350	1.228	23.384	2.308	5.85	33.9	56
G28	4	175.0	51.45	28.12	0.710	14.285	1.143	23.805	2.157	6.25	33.5	57
G28	5	175.0	51.02	28.12	0.700	14.290	1.153	23.785	2.167	6.20	34.0	56
G28	6	166.0	48.75	28.00	0.675	14.250	1.083	23.805	2.097	6.58	35.3	52
G28	7	165.0	48.75	28.00	0.675	14.250	1.083	23.805	2.097	6.58	35.3	52
G28	3	165.0	48.47	28.00	0.660	12.500	1.267	23.388	2.306	4.93	35.4	51
G28	5	165.0	48.19	28.00	0.660	14.250	1.093	23.785	2.107	6.52	36.0	50
G28	2	162.5	47.81	28.00	0.650	12.000	1.305	23.153	2.424	4.60	35.6	51
G28	8	156.0	45.95	27.88	0.625	14.215	1.033	23.785	2.047	6.88	38.1	44
G28	4	156.0	45.93	27.88	0.635	14.210	1.023	23.805	2.037	6.95	37.5	46
G28	8	147.0	43.27	27.75	0.595	14.185	0.968	23.785	1.982	7.33	40.0	40
G28	4	145.0	42.69	27.75	0.585	14.160	0.958	23.805	1.972	7.39	40.7	39
B28	1	133.0	39.09	28.59	0.630	10.160	1.093	24.880	1.855	4.65	39.5	41
B28	1	119.0	35.11	28.38	0.565	10.095	0.988	24.880	1.750	5.11	44.0	33
B28	9	113.0	32.98	28.12	0.540	10.030	0.938	24.722	1.699	5.35	45.8	31
B28	4	112.0	32.95	28.25	0.535	10.065	0.967	24.702	1.774	5.20	46.2	30
B28	9	106.0	30.93	28.00	0.510	10.000	0.878	24.722	1.639	5.70	48.5	27
B28	11	106.0	30.88	28.00	0.500	10.000	0.889	24.668	1.666	5.63	49.3	26
B28	2	105.0	31.04	28.00	0.480	9.600	0.965	24.405	1.797	4.97	50.8	25
B28	3	105.0	30.88	28.00	0.500	10.000	0.889	24.668	1.666	5.63	49.3	26
B28	4	104.0	30.66	28.12	0.500	10.030	0.858	24.880	1.620	5.85	49.8	26
B28	9	100.0	29.18	27.88	0.490	9.980	0.818	24.722	1.579	6.10	50.5	25
B28	4	97.0	28.61	28.00	0.470	10.000	0.798	24.880	1.560	6.27	52.9	23
B28	8	92.0	27.02	27.75	0.450	9.940	0.750	24.722	1.514	6.63	54.9	21
B28	4	91.0	26.86	27.88	0.450	9.980	0.738	24.880	1.500	6.77	55.3	21
B28	10	85.0	24.96	27.69	0.450	9.980	0.641	24.880	1.405	7.79	55.3	21
CB272	6	190.0	55.87	27.60	0.756	14.176	1.284	23.105	2.247	5.52	30.6	-
27WF, CB272	12	177.0	52.10	27.31	0.725	14.090	1.190	23.085	2.113	5.92	31.8	63
27WF, B27a	1	177.0	52.10	27.31	0.725	14.090	1.190	23.467	1.921	5.92	32.4	61

Table 2.3.1 Dimensions and Primary Properties – Steel Sections 1887-1952

Designation	X ₁ ksi	X ₂ x 106 (1/ksi) ²	Elastic Properties						Plastic Modulus	
			Axis x-x			Axis y-y			Z _x in.3	Z _y in.3
			I _x in.4	S _x in.3	r _x in.	I _y in.4	S _y in.3	r _y in.		
CB302N	2400	4683	8301.4	553.4	12.52	552.7	79.0	3.23	613.8	121.3
30WF, CB302	2244	6114	8328.2	555.2	12.55	585.6	78.1	3.33	616.3	129.7
30WF, CB302	2305	5489	8328.2	555.2	12.55	585.6	78.1	3.33	616.3	129.7
G30	2880	2348	7851.8	523.5	12.37	346.4	57.7	2.60	595.6	94.0
G30	2315	5526	7806.5	524.8	12.38	514.1	68.8	3.18	584.2	111.9
G30	2295	5661	7895.2	528.5	12.47	519.1	69.3	3.20	587.3	112.6
30WF, B30a	2215	6490	7891.5	528.2	12.48	550.1	73.4	3.30	586.0	122.5
30WF, CB302	2151	7306	7891.5	528.2	12.48	550.1	73.4	3.30	586.0	122.5
CB301	2543	4412	7326.7	476.7	12.29	258.7	48.2	2.31	546.8	76.1
B30	2638	3739	7270.7	474.4	12.31	239.8	44.9	2.24	543.3	72.9
CB301	2340	6105	6663.7	436.4	12.25	233.4	43.8	2.29	498.6	68.8
B30	2432	5135	6606.6	434.1	12.26	214.5	40.4	2.21	495.1	65.6
CB301	2150	8523	6049.5	398.7	12.21	210.1	39.6	2.28	453.7	62.1
B30	2252	6966	6026.7	398.5	12.21	192.6	36.4	2.18	453.1	59.2
CB301	2106	9253	5907.3	389.9	12.20	204.8	38.7	2.27	443.4	60.5
30WF, B30	2096	9533	5753.1	379.7	12.17	185.0	35.1	2.18	432.3	58.3
30WF, CB301	2059	10224	5753.1	379.7	12.17	185.0	35.1	2.18	432.3	58.3
CB302N	2038	10526	5745.6	379.1	12.21	197.1	37.4	2.26	431.2	58.5
B30	2131	8801	5738.5	378.7	12.21	177.9	33.7	2.15	430.6	55.0
B30	2122	8789	5622.7	373.4	12.19	177.6	33.7	2.17	423.2	54.8
B30	2135	8614	5566.5	369.6	12.18	177.5	33.7	2.18	423.3	54.8
CB301	1972	11966	5486.7	363.8	12.17	189.0	35.8	2.26	412.5	56.0
CB301	1957	12321	5441.7	361.0	12.17	187.4	35.5	2.26	409.1	55.5
30WF, B30	1976	12121	5347.1	354.6	12.11	169.7	32.3	2.16	403.1	53.9
30WF, CB301	1938	13115	5347.1	354.6	12.11	169.7	32.3	2.16	403.1	53.9
B30	1994	11769	5235.7	347.7	12.08	158.4	30.1	2.10	395.8	49.4
CB301N	1898	14301	5238.2	347.8	12.09	177.3	33.7	2.22	395.9	52.8
B30	2010	10901	5269.7	351.3	12.16	164.3	31.3	2.15	397.5	50.9
B30	2023	10673	5213.6	347.6	12.14	164.3	31.3	2.16	397.5	50.9
B30	2035	10282	5239.6	349.3	12.18	165.0	31.4	2.16	398.7	51.2
B30	2035	10282	5239.6	349.3	12.18	165.0	31.4	2.16	398.7	51.2
B30	2173	7754	5270.9	351.4	12.23	149.7	29.9	2.11	401.3	49.3
30WF, B30	1861	15727	4919.1	327.9	12.00	153.2	29.2	2.12	373.1	49.1
30WF, CB301	1819	17222	4919.1	327.9	12.00	153.2	29.2	2.12	373.1	49.1
B30	1891	14640	4894.1	326.3	12.02	145.6	27.7	2.07	371.1	45.6
CB301N	1796	17983	4896.6	326.4	12.03	164.5	31.3	2.20	371.3	49.0
CB301	1809	16766	4985.3	332.4	12.14	170.6	32.5	2.25	375.3	50.6
B30	1912	13438	4942.9	330.8	12.09	151.8	29.0	2.12	374.2	47.3
B30	1925	13139	4886.8	327.1	12.08	151.8	29.0	2.13	374.2	47.3
B30	1840	15908	4687.7	314.8	12.02	141.8	27.1	2.09	356.3	44.4
B30	1790	18422	4556.2	305.0	11.96	132.9	25.4	2.04	346.7	41.9
CB301N	1691	23034	4554.2	304.8	11.97	151.6	29.0	2.18	346.4	45.3
30WF	1747	20940	4461.0	299.2	11.85	135.1	25.8	2.06	341.3	43.9
30WF, CB301	1701	23285	4461.0	299.2	11.85	135.1	25.8	2.06	341.3	43.9
G28	2760	2685	7604.0	537.2	11.79	539.7	75.5	3.14	600.9	121.4
G28a	2857	2295	7269.0	519.2	11.72	507.6	70.7	3.09	584.9	116.6
G28a	2768	2594	7264.7	518.9	11.72	533.3	74.3	3.18	583.7	119.9
G28	2607	3421	7026.0	499.7	11.69	491.1	68.6	3.09	558.6	111.2
G28	2625	3305	6988.7	497.1	11.70	496.2	69.4	3.12	560.6	112.2
G28	2485	4131	6624.6	473.2	11.66	458.3	64.3	3.07	527.7	104.2
G28	2485	4131	6624.6	473.2	11.66	458.3	64.3	3.07	527.7	104.2
G28	2819	2476	6562.7	468.8	11.64	371.9	59.5	2.77	530.0	95.5
G28	2497	4008	6577.9	469.9	11.68	462.8	65.0	3.10	528.7	105.1
G28	2931	2120	6465.1	461.8	11.63	328.2	54.7	2.62	522.2	89.0
G28	2361	4986	6251.3	448.4	11.66	430.5	60.6	3.06	498.0	98.2
G28	2358	5068	6218.6	446.1	11.64	425.4	59.9	3.04	496.0	97.2
G28	2239	6178	5840.4	420.9	11.62	396.6	55.9	3.03	466.5	91.0
G28	2213	6459	5772.3	416.0	11.63	389.8	55.1	3.02	460.7	89.6
B28	2422	5190	5204.0	364.0	11.54	175.3	34.5	2.12	414.9	56.0
B28	2197	7576	4647.4	327.5	11.50	153.7	30.5	2.09	371.4	49.4
B28	2123	8721	4285.5	304.8	11.40	142.3	28.4	2.08	348.5	46.1
B28	2198	7547	4328.5	306.4	11.46	141.2	28.1	2.07	358.0	47.2
B28	2004	10987	3993.8	285.3	11.36	130.9	26.2	2.06	325.7	42.6
B28	2016	10570	4014.1	286.7	11.40	131.5	26.3	2.06	326.7	42.9
B28	1606	14105	4089.1	292.1	11.43	122.6	25.5	1.98	331.8	42.0
B28	2016	10570	4014.1	286.7	11.40	131.5	26.3	2.06	326.7	42.9
B28	1941	12441	4003.3	284.7	11.43	128.7	25.7	2.05	321.5	41.8
B28	1899	13756	3723.4	267.1	11.30	120.2	24.1	2.03	305.0	39.3
B28	1823	15998	3711.5	265.1	11.39	117.4	23.5	2.03	298.7	38.3
B28	1743	19203	3443.0	248.1	11.29	108.0	21.7	2.00	278.7	35.4
B28	1719	20461	3441.1	246.9	11.32	106.7	21.4	1.99	278.1	35.1
B28	1603	28650	3075.2	222.1	11.10	91.0	18.2	1.91	251.2	30.2
CB272	2805	2502	7376.9	534.6	11.49	610.7	86.2	3.31	597.4	132.6
27WF, CB272	2640	3216	6728.6	492.8	11.36	518.9	73.7	3.16	550.6	121.4
27WF, B27a	2699	2943	6728.6	492.8	11.36	518.9	73.7	3.16	550.6	121.4

Table 2.3.1 Dimensions and Primary Properties – Steel Sections 1887-1952

Designation	Source Reference Number	Wt. per ft lb	Area	Depth	Web Thickness	Flange Width	Average Flange Thickness	Distance	Distance	Compact Section Criteria		
			A	d	t_w	b_f	t_f	T	k	$b_f/2t_f$	h/t_w	F_y "
			in.2	in.	in.	in.	in.	in.	in.			ksi
CB272	6	175.0	51.47	27.40	0.698	14.118	1.185	23.105	2.148	5.96	33.1	59
CB272N	10	175.0	51.46	27.45	0.671	14.091	1.211	23.105	2.174	5.82	34.4	54
CB272N	10	166.0	48.81	27.33	0.638	14.058	1.149	23.105	2.112	6.12	36.2	49
27WF, CB272	11	163.0	47.93	27.12	0.670	14.035	1.095	23.085	2.018	6.41	34.5	54
27WF, B27a	2	163.0	47.93	27.12	0.670	14.035	1.095	23.467	1.826	6.41	35.0	52
CB272	6	160.0	47.04	27.20	0.639	14.059	1.085	23.105	2.048	6.48	36.2	49
27WF, CB272	13	160.0	47.04	27.08	0.658	14.023	1.075	23.085	1.998	6.52	35.1	52
27WF, B27a	3	160.0	47.04	27.08	0.658	14.023	1.075	23.467	1.806	6.52	35.7	51
CB272N	10	156.0	45.87	27.19	0.600	14.020	1.081	23.105	2.044	6.48	38.5	43
27WF, CB272	11	154.0	45.30	27.00	0.635	14.000	1.035	23.085	1.958	6.76	36.4	49
27WF, B27a	2	154.0	45.30	27.00	0.635	14.000	1.035	23.467	1.766	6.76	37.0	47
27WF, B27a	1	145.0	42.68	26.88	0.600	13.965	0.975	23.467	1.706	7.16	39.1	42
27WF, CB272	12	145.0	42.68	26.88	0.600	13.965	0.975	23.085	1.898	7.16	38.5	43
CB272N	7	145.0	42.64	27.00	0.580	14.000	0.985	23.105	1.948	7.11	39.8	41
CB271	8	137.0	40.29	27.74	0.688	9.977	1.126	24.065	1.839	4.43	35.0	53
CB271	8	124.0	36.47	27.54	0.624	9.913	1.023	24.065	1.736	4.85	38.6	43
27WF, CB271	12	114.0	33.53	27.28	0.570	10.070	0.932	24.011	1.635	5.40	42.1	36
27WF	1	114.0	33.53	27.28	0.570	10.070	0.932	24.288	1.496	5.40	42.6	35
CB271N	10	112.0	32.94	27.58	0.527	10.077	0.949	24.259	1.662	5.31	46.0	30
CB271	6	112.0	32.94	27.34	0.566	9.855	0.925	24.065	1.638	5.33	42.5	36
27WF, CB271	11	106.0	31.17	27.14	0.535	10.035	0.862	24.011	1.565	5.82	44.9	32
27WF, B27	2	106.0	31.17	27.14	0.535	10.035	0.862	24.288	1.426	5.82	45.4	31
CB27N	10	104.0	30.60	27.45	0.490	10.040	0.883	24.259	1.596	5.69	49.5	26
27WF, CB271	13	102.0	30.01	27.07	0.518	10.018	0.827	24.011	1.530	6.06	46.4	30
27WF, B27	3	102.0	30.01	27.07	0.518	10.018	0.827	24.288	1.391	6.06	46.9	29
CB271	6	101.0	29.70	27.17	0.510	9.799	0.838	24.065	1.551	5.85	47.2	29
27WF, CB27	11	98.0	28.82	27.00	0.500	10.000	0.792	24.011	1.495	6.31	48.0	28
27WF, B27	2	98.0	28.82	27.00	0.500	10.000	0.792	24.288	1.356	6.31	48.6	27
CB271N	10	97.0	28.53	27.33	0.460	10.010	0.821	24.259	1.534	6.10	52.7	23
27WF, CB271	13	94.0	27.65	26.91	0.490	9.990	0.747	24.011	1.450	6.69	49.0	27
27WF, B27	3	94.0	27.65	26.91	0.490	9.990	0.747	24.288	1.311	6.69	49.6	26
27WF, B27	2	91.0	26.77	26.84	0.483	9.830	0.712	24.288	1.276	6.90	50.3	25
27WF, CB271	11	91.0	26.77	26.84	0.483	9.983	0.712	24.011	1.415	7.01	49.7	26
CB271N	10	91.0	26.76	27.16	0.455	10.005	0.739	24.259	1.452	6.77	53.3	23
CB271	6	91.0	26.76	27.00	0.461	9.750	0.755	24.065	1.468	6.46	52.2	24
B61	5	90.0	26.34	27.00	0.524	9.000	0.708	24.306	1.347	6.36	46.4	30
CB271N	10	85.0	25.00	27.00	0.450	10.000	0.658	24.259	1.371	7.60	53.9	22
CB271	9	85.0	25.00	26.82	0.461	9.750	0.665	24.065	1.378	7.33	52.2	24
B31	4	83.0	24.41	27.00	0.424	7.500	0.891	23.418	1.791	4.21	55.2	21
G26	1	171.0	50.30	26.38	0.685	14.090	1.188	22.067	2.157	5.93	32.2	62
G26	2	160.0	47.25	26.12	0.670	13.790	1.119	21.957	2.082	6.16	32.8	60
G26a	3	160.0	47.00	26.00	0.630	13.600	1.181	21.399	2.301	5.76	34.0	56
G26a	4	160.0	46.91	26.00	0.630	13.600	1.177	21.599	2.200	5.78	34.3	55
G26	5	160.0	46.85	26.12	0.670	13.790	1.119	21.957	2.082	6.16	32.8	60
G26	1	157.0	46.19	26.19	0.630	14.035	1.093	22.067	2.062	6.42	35.0	52
G26	2	151.0	44.55	26.00	0.630	13.750	1.059	21.957	2.022	6.50	34.9	53
G26	5	151.0	44.16	26.00	0.630	13.750	1.059	21.957	2.022	6.50	34.9	53
G26	3	150.0	44.13	26.00	0.620	12.000	1.231	21.399	2.301	4.88	34.5	54
G26	4	150.0	43.94	26.00	0.630	12.000	1.212	21.599	2.200	4.95	34.3	55
G26	1	145.0	42.61	26.00	0.595	14.000	0.998	22.067	1.967	7.02	37.1	47
G26	2	144.0	42.38	25.88	0.610	13.730	0.999	21.957	1.962	6.88	36.0	50
G26	5	144.0	41.99	25.88	0.610	13.730	0.999	21.957	1.962	6.88	36.0	50
G26	6	138.0	40.65	25.81	0.580	13.700	0.964	21.957	1.927	7.11	37.9	45
B26	1	101.0	29.69	26.31	0.515	9.565	0.880	23.127	1.591	5.43	44.9	32
B26	2	98.0	28.69	26.12	0.500	9.530	0.854	22.991	1.564	5.58	46.0	30
B26	7	98.0	28.47	26.12	0.500	9.530	0.854	22.991	1.564	5.58	46.0	30
B26	1	91.0	26.83	26.12	0.475	9.525	0.785	23.127	1.496	6.07	48.7	27
B26	2	91.0	26.76	26.00	0.470	9.500	0.794	22.991	1.504	5.99	48.9	27
B26	7	91.0	26.55	26.00	0.470	9.500	0.794	22.991	1.504	5.99	48.9	27
B26	8	91.0	26.49	26.00	0.460	9.500	0.804	22.941	1.529	5.91	49.9	26
B26	3	90.0	26.63	26.00	0.440	9.150	0.872	22.684	1.658	5.25	51.6	24
B26	4	90.0	26.49	26.00	0.460	9.500	0.804	22.941	1.529	5.91	49.9	26
B26	2	85.5	25.11	25.88	0.450	9.480	0.734	22.991	1.444	6.46	51.1	25
B26	7	85.5	24.89	25.88	0.450	9.480	0.734	22.991	1.444	6.46	51.1	25
B26	1	85.0	25.04	26.00	0.450	9.500	0.725	23.127	1.436	6.55	51.4	24
B26	6	81.0	23.90	25.78	0.440	9.470	0.684	22.991	1.394	6.93	52.3	24
CB244	19	160.0	47.06	24.66	0.670	14.123	1.119	20.701	1.982	6.31	30.9	-
CB244N	20	160.0	47.05	24.71	0.665	14.095	1.124	20.741	1.987	6.27	31.2	-
24WF, CB244	22	160.0	47.04	24.72	0.656	14.091	1.135	20.925	1.898	6.21	31.9	63
24WF, B24b	13	160.0	47.04	24.72	0.656	14.091	1.135	21.155	1.783	6.21	32.2	62
G24a	11	160.0	47.04	24.72	0.660	14.090	1.131	20.603	2.059	6.23	31.2	-
G24a	11	150.0	44.17	24.56	0.635	14.065	1.051	20.603	1.979	6.69	32.4	61
CB244N	20	150.0	44.12	24.56	0.633	14.063	1.048	20.741	1.911	6.71	32.8	60
24WF, CB243	21	150.0	44.10	24.56	0.628	14.063	1.055	20.925	1.818	6.66	33.3	58
24WF, B24b	12	150.0	44.10	24.56	0.628	14.063	1.055	21.155	1.703	6.66	33.7	57

Table 2.3.1 Dimensions and Primary Properties – Steel Sections 1887-1952

Designation	X ₁ ksi	X ₂ x 106 (1/ksi) ²	Elastic Properties						Plastic Modulus	
			Axis x-x			Axis y-y			Z _x in.3	Z _y in.3
			I _x	S _x	r _x	I _y	S _y	r _y		
			in.4	in.3	in.	in.4	in.3	in.		
CB272	2597	3379	6746.8	492.5	11.45	556.6	78.9	3.29	547.9	121.1
CB272N	2607	3260	6838.3	498.2	11.53	565.5	80.3	3.31	552.9	123.0
CB272N	2480	3962	6454.5	472.4	11.50	532.7	75.8	3.30	522.8	116.1
27WF, CB272	2441	4379	6141.5	452.9	11.32	468.7	66.8	3.13	504.1	110.6
27WF, B27A	2503	3958	6141.5	452.9	11.32	468.7	66.8	3.13	504.1	110.6
CB272	2387	4698	6121.8	450.1	11.41	503.2	71.6	3.27	498.4	109.8
27WF, CB272	2398	4691	6018.6	444.5	11.31	458.0	65.3	3.12	494.3	108.4
27WF, B27a	2461	4227	6018.6	444.5	11.31	458.0	65.3	3.12	494.3	108.4
CB272N	2340	4975	6035.6	443.9	11.47	497.1	70.9	3.29	489.7	108.5
27WF, CB272	2314	5396	5775.8	427.8	11.29	437.6	62.5	3.11	474.9	103.9
27WF, B27a	2379	4831	5775.8	427.8	11.29	437.6	62.5	3.11	474.9	103.9
27WF, B27a	2255	5961	5414.3	402.9	11.26	406.9	58.3	3.09	445.9	97.3
27WF, CB272	2188	6733	5414.3	402.9	11.26	406.9	58.3	3.09	445.9	97.3
CB272N	2177	6740	5508.7	408.1	11.37	451.0	64.4	3.25	449.6	98.6
CB271	2539	4407	4975.9	358.7	11.11	187.1	37.5	2.16	410.8	59.1
CB271	2312	6356	4472.1	324.8	11.07	166.7	33.6	2.14	370.2	52.7
27WF, CB271	2112	8979	4080.5	299.2	11.03	149.6	29.7	2.11	339.3	49.3
27WF	2152	8326	4080.5	299.2	11.03	149.6	29.7	2.11	339.3	49.3
CB271N	2057	9574	4182.7	303.3	11.27	162.2	32.2	2.22	341.6	50.0
CB271	2099	9285	4007.6	293.2	11.03	148.0	30.0	2.12	332.7	47.0
27WF, CB271	1970	11880	3761.2	277.2	10.98	136.1	27.1	2.09	313.7	45.2
27WF, B27	2012	10906	3761.2	277.2	10.98	136.1	27.1	2.09	313.7	45.2
CB27N	1918	12586	3867.1	281.8	11.24	149.2	29.7	2.21	316.3	46.0
27WF, CB271	1900	13757	3604.1	266.3	10.96	129.5	25.9	2.08	301.1	43.2
27WF, B27	1943	12557	3604.1	266.3	10.96	129.5	25.9	2.08	301.1	43.2
CB271	1905	13573	3595.7	264.7	11.00	131.7	26.9	2.11	299.0	41.9
27WF, CB27	1828	16058	3446.5	255.3	10.94	122.9	24.6	2.07	288.3	41.2
27WF, B27	1873	14563	3446.5	255.3	10.94	122.9	24.6	2.07	288.3	41.2
CB271N	1795	16427	3582.6	262.2	11.21	137.5	27.5	2.20	293.7	42.5
27WF, CB271	1756	19129	3266.7	242.8	10.87	115.1	23.0	2.04	274.4	38.8
27WF, B27	1803	17188	3266.7	242.8	10.87	115.1	23.0	2.04	274.4	38.8
27WF, B27	1742	20015	3129.2	233.2	10.81	109.0	21.8	2.02	260.9	35.9
27WF, CB271	1702	21951	3129.2	233.2	10.81	109.0	21.8	2.02	263.7	37.0
CB271N	1683	22164	3269.7	240.1	11.05	123.6	24.7	2.15	270.4	38.3
CB271	1726	20052	3217.0	238.3	10.97	116.9	24.0	2.09	268.1	37.2
B61	1860	17103	2958.3	219.1	10.60	75.3	16.7	1.69	253.1	28.1
CB271N	1570	30342	2964.3	219.6	10.89	109.9	22.0	2.10	247.5	34.2
CB271	1614	27585	2899.3	216.2	10.77	103.0	21.1	2.03	244.5	33.0
B31	2090	9525	2888.6	214.0	10.88	53.1	14.1	1.47	241.6	23.7
G26	2816	2407	6148.0	466.1	11.06	492.6	69.9	3.13	519.8	112.3
G26	2711	2850	5629.4	431.0	10.92	432.8	62.8	3.03	480.8	101.2
G26a	2910	2082	5618.7	432.2	10.93	414.5	61.0	2.97	485.8	100.1
G26a	2821	2344	5620.8	432.4	10.95	435.7	64.1	3.05	485.0	103.0
G26	2724	2797	5576.6	427.0	10.91	432.8	62.8	3.04	480.8	101.2
G26	2610	3239	5603.2	427.9	11.01	442.7	63.1	3.10	475.2	101.6
G26	2573	3484	5289.8	406.9	10.90	402.8	58.6	3.01	452.5	94.6
G26	2587	3416	5237.1	402.9	10.89	402.7	58.6	3.02	452.5	94.6
G26	2982	1933	5200.4	400.0	10.86	306.5	51.1	2.63	451.2	83.2
G26	2902	2180	5153.9	396.5	10.83	314.6	52.4	2.68	447.8	84.1
G26	2427	4356	5098.0	392.2	10.94	395.7	56.5	3.05	434.5	91.5
G26	2460	4194	4983.4	385.1	10.84	375.0	54.6	2.97	427.8	88.5
G26	2475	4105	4930.6	381.0	10.84	375.0	54.6	2.99	427.8	88.5
G26	2372	4808	4779.9	370.4	10.84	357.4	52.2	2.97	410.4	84.6
B26	2124	8658	3385.7	257.4	10.68	115.7	24.2	1.97	291.5	39.3
B26	2076	9457	3231.2	247.4	10.61	110.6	23.2	1.96	279.9	37.7
B26	2088	9282	3200.9	245.1	10.60	110.6	23.2	1.97	279.9	37.7
B26	1934	12693	3014.1	230.8	10.60	100.4	21.1	1.93	260.9	34.4
B26	1949	12189	2993.1	230.2	10.58	100.9	21.2	1.94	259.9	34.6
B26	1961	11947	2962.8	227.9	10.56	100.9	21.2	1.95	259.9	34.6
B26	1972	11510	2977.2	229.0	10.60	101.2	21.3	1.95	260.6	34.8
B26	2104	8535	3043.1	234.1	10.71	93.4	20.4	1.87	265.0	34.2
B26	1972	11510	2977.2	229.0	10.60	101.2	21.3	1.95	260.6	34.8
B26	1836	15643	2772.5	214.3	10.51	91.7	19.3	1.91	241.8	31.6
B26	1849	15295	2742.2	211.9	10.50	91.6	19.3	1.92	241.8	31.6
B26	1816	16464	2783.4	214.1	10.54	91.0	19.2	1.91	241.8	31.4
B26	1754	19117	2600.1	201.7	10.43	84.3	17.8	1.88	227.9	29.3
CB244	2706	2780	5065.7	410.8	10.38	526.0	74.5	3.34	456.3	114.1
CB244N	2704	2778	5092.2	412.1	10.40	525.2	74.5	3.34	457.6	114.1
24WF, CB244	2695	2794	5110.3	413.5	10.42	492.6	69.9	3.23	459.9	115.1
24WF, B24b	2767	2514	5110.3	413.5	10.42	492.6	69.9	3.23	459.9	115.1
G24a	2863	2212	5092.6	412.0	10.40	465.9	66.1	3.15	458.8	106.3
G24a	2704	2799	4719.6	384.3	10.34	426.1	60.6	3.11	427.2	97.8
CB244N	2543	3557	4727.5	384.9	10.35	486.4	69.2	3.32	426.4	105.9
24WF, CB243	2531	3608	4733.5	385.5	10.36	452.5	64.3	3.20	427.9	106.5
24WF, B24b	2607	3204	4733.5	385.5	10.36	452.5	64.3	3.20	427.9	106.5

Table 2.3.1 Dimensions and Primary Properties -- Steel Sections 1887-1952

Designation	Source Reference Number	Wt. per ft lb	Area	Depth	Web Thickness	Flange Width	Average Flange Thickness	Distance	Distance	Compact Section Criteria		
			A	d	t _w	b _f	t _f	T	k	b _f /2t _f	h/t _w	F _y "
			in.2	in.	in.	in.	in.	in.	in.	in.		
CB244	19	150.0	44.10	24.53	0.629	14.082	1.050	20.701	1.913	6.71	32.9	59
G24a	5	149.0	43.57	24.12	0.650	13.290	1.104	20.091	2.015	6.02	30.9	-
G24a	10	148.0	43.68	24.12	0.640	13.280	1.104	20.091	2.015	6.02	31.4	-
24WF, 24b	15	145.0	42.62	24.49	0.608	14.043	1.020	21.155	1.668	6.88	34.8	53
24WF, CB243	23	145.0	42.62	24.49	0.608	14.043	1.020	20.925	1.783	6.88	34.4	54
G24a	5	141.0	41.02	24.00	0.610	13.250	1.044	20.091	1.955	6.35	32.9	59
G24a	11	140.0	41.21	24.41	0.600	14.030	0.976	20.603	1.904	7.19	34.3	55
24WF, B24b	12	140.0	41.16	24.41	0.594	14.029	0.980	21.155	1.628	7.16	35.6	51
24WF, CB243	21	140.0	41.16	24.41	0.594	14.029	0.980	20.925	1.743	7.16	35.2	52
CB244	19	140.0	41.16	24.39	0.588	14.041	0.981	20.701	1.844	7.16	35.2	52
G24a	2	140.0	41.16	24.00	0.600	13.000	1.079	19.989	2.006	6.02	33.3	58
CB244N	20	140.0	41.15	24.41	0.601	14.031	0.970	20.741	1.833	7.23	34.5	54
G24a	10	140.0	41.13	24.00	0.600	13.240	1.044	20.091	1.955	6.34	33.5	57
G24a	1	140.0	41.03	24.00	0.560	13.000	1.109	19.709	2.146	5.86	35.2	52
G24a	5	133.0	38.71	23.88	0.580	13.220	0.984	20.091	1.895	6.72	34.6	54
G24a	10	132.0	38.82	23.88	0.570	13.210	0.984	20.091	1.895	6.72	35.2	52
CB244	19	130.0	38.23	24.25	0.547	14.000	0.912	20.701	1.775	7.68	37.8	45
G24a	11	130.0	38.23	24.25	0.570	14.000	0.896	20.603	1.824	7.81	36.1	49
24WF, B24B	13	130.0	38.21	24.25	0.565	14.000	0.900	21.155	1.548	7.78	37.4	46
24WF, CB243	22	130.0	38.21	24.25	0.565	14.000	0.900	20.925	1.663	7.78	37.0	47
CB244N	20	130.0	38.21	24.25	0.570	14.000	0.892	20.741	1.755	7.85	36.4	49
G24	5	129.0	37.74	24.12	0.580	12.290	1.014	20.392	1.864	6.06	35.2	52
G24	10	128.0	37.79	24.12	0.570	12.280	1.014	20.392	1.864	6.06	35.8	50
G24	5	121.0	35.30	24.00	0.540	12.250	0.954	20.392	1.804	6.42	37.8	45
G24	2	120.0	35.38	24.00	0.530	12.000	0.988	20.213	1.894	6.07	38.1	44
G24	10	120.0	35.36	24.00	0.530	12.240	0.954	20.392	1.804	6.42	38.5	43
G24	11	120.0	35.36	24.31	0.560	12.090	0.930	20.758	1.776	6.50	37.1	47
G24	1	120.0	35.31	24.00	0.510	12.000	1.004	19.979	2.011	5.98	39.2	42
CB243	19	120.0	35.29	24.31	0.539	12.089	0.942	20.701	1.805	6.42	38.4	44
24WF, CB242	22	120.0	35.29	24.31	0.556	12.088	0.930	20.925	1.693	6.50	37.6	45
24WF, B24a	14	120.0	35.29	24.31	0.556	12.088	0.930	21.238	1.536	6.50	38.2	44
CB243N	20	120.0	35.28	24.31	0.559	12.089	0.922	20.741	1.785	6.56	37.1	47
G24	5	114.0	33.12	23.88	0.510	12.220	0.894	20.392	1.744	6.83	40.0	40
G24	10	113.0	33.18	23.88	0.500	12.210	0.894	20.392	1.744	6.83	40.8	39
24WF, B24a	14	110.0	32.36	24.16	0.510	12.042	0.855	21.238	1.461	7.04	41.6	37
24WF, CB242	22	110.0	32.36	24.16	0.510	12.042	0.855	20.925	1.618	7.04	41.0	38
CB243N	20	110.0	32.35	24.16	0.513	12.043	0.847	20.741	1.710	7.11	40.4	39
CB243	19	110.0	32.34	24.16	0.494	12.044	0.865	20.701	1.728	6.96	41.9	37
G24	11	110.0	32.34	24.16	0.510	12.040	0.855	20.758	1.701	7.04	40.7	39
G24	9	108.0	31.84	23.78	0.495	12.205	0.844	20.392	1.694	7.23	41.2	38
G24	10	107.0	31.60	23.78	0.485	12.195	0.844	20.392	1.694	7.22	42.0	36
B24b	10	104.5	30.88	24.09	0.550	9.775	0.942	20.694	1.698	5.19	37.6	45
G24b	4	104.5	30.63	24.09	0.550	9.775	0.942	20.694	1.698	5.19	37.6	45
G24	11	100.0	29.45	24.00	0.470	12.000	0.775	20.758	1.621	7.74	44.2	33
24WF, B24a	14	100.0	29.43	24.00	0.468	12.000	0.775	21.238	1.381	7.74	45.4	31
24WF, CB242	22	100.0	29.43	24.00	0.468	12.000	0.775	20.925	1.538	7.74	44.7	32
CB243	19	100.0	29.41	24.00	0.450	12.000	0.787	20.701	1.650	7.62	46.0	30
CB243N	20	100.0	29.39	24.00	0.470	12.000	0.767	20.741	1.630	7.82	44.1	33
B24b	10	99.5	29.40	24.00	0.525	9.750	0.897	20.694	1.653	5.43	39.4	41
B24b	4	99.5	29.15	24.00	0.525	9.750	0.897	20.694	1.653	5.43	39.4	41
B24b	10	95.5	28.05	23.91	0.505	9.730	0.852	20.694	1.608	5.71	41.0	38
B24b	4	95.5	27.79	23.91	0.505	9.730	0.852	20.694	1.608	5.71	41.0	38
CB242	19	94.0	27.64	24.31	0.499	9.844	0.817	21.349	1.480	6.02	42.8	35
24WF, CB241	22	94.0	27.63	24.29	0.516	9.061	0.872	21.341	1.475	5.20	41.4	38
24WF, B24	13	94.0	27.63	24.29	0.516	9.061	0.872	21.585	1.353	5.20	41.8	37
B24a	11	93.0	27.36	24.26	0.485	10.040	0.805	21.207	1.526	6.24	43.7	34
CB242N	20	93.0	27.34	24.26	0.481	10.031	0.810	21.415	1.423	6.19	44.5	32
B24a	10	90.5	26.47	24.12	0.475	9.515	0.819	21.061	1.529	5.81	44.3	33
24WF, B24	12	87.0	25.58	24.16	0.480	9.025	0.807	21.585	1.288	5.59	45.0	32
24WF, CB241	21	87.0	25.58	24.16	0.480	9.025	0.807	21.341	1.410	5.59	44.5	33
B24a	11	85.0	24.99	24.12	0.445	10.000	0.735	21.207	1.456	6.80	47.7	28
CB242	19	85.0	24.99	24.15	0.452	9.797	0.740	21.349	1.403	6.62	47.2	29
CB242N	20	85.0	24.99	24.10	0.450	10.000	0.730	21.415	1.343	6.85	47.6	28
B24a	10	84.5	24.97	24.00	0.460	9.500	0.759	21.061	1.469	6.26	45.8	31
B24a	6	84.5	24.80	24.00	0.460	9.250	0.783	20.995	1.502	5.91	45.6	31
B24a	8	84.5	24.75	24.00	0.460	9.500	0.759	21.061	1.469	6.26	45.8	31
B24a	2	84.0	24.80	24.00	0.460	9.250	0.783	20.995	1.502	5.91	45.6	31
B24a	1	84.0	24.79	24.00	0.450	8.850	0.833	20.765	1.617	5.32	46.1	30
24WF, B24	15	84.0	24.71	24.09	0.470	9.015	0.772	21.585	1.253	5.84	45.9	31
24WF, CB241	23	84.0	24.71	24.09	0.470	9.015	0.772	21.341	1.375	5.84	45.4	31
B24	3	83.0	24.59	24.00	0.520	9.130	0.704	21.245	1.378	6.49	40.9	39
B24	1	82.0	24.33	24.00	0.500	8.830	0.741	21.087	1.456	5.96	42.2	36
B24	11	81.0	23.86	24.12	0.455	9.040	0.740	21.321	1.400	6.11	46.9	29
CB241N	20	81.0	23.84	24.12	0.453	9.041	0.740	21.415	1.353	6.11	47.3	29
24WF, CB241	21	80.0	23.54	24.00	0.455	9.000	0.727	21.341	1.330	6.19	46.9	29
24WF, B24	12	80.0	23.54	24.00	0.455	9.000	0.727	21.585	1.208	6.19	47.4	29

Table 2.3.1 Dimensions and Primary Properties -- Steel Sections 1887-1952

Designation	X ₁ ksi	X ₂ x 106 (1/ksi) ²	Elastic Properties						Plastic Modulus	
			Axis x-x			Axis y-y			Z _x in.3	Z _y in.3
			I _x	S _x	r _x	I _y	S _y	r _y		
			in.4	in.3	in.	in.4	in.3	in.		
CB244	2545	3530	4720.5	384.9	10.35	489.3	69.5	3.33	426.2	106.3
G24a	2891	2165	4451.1	369.1	10.11	383.3	57.7	2.97	415.3	92.8
G24a	2865	2227	4478.0	371.3	10.13	382.5	57.6	2.96	413.8	92.5
24WF, 24b	2528	3615	4561.0	372.5	10.34	434.3	61.8	3.19	412.8	102.6
24WF, CB243	2450	4097	4561.0	372.5	10.34	434.3	61.8	3.19	412.8	102.6
G24a	2742	2654	4174.2	347.9	10.09	356.4	53.8	2.95	390.3	86.6
G24a	2542	3585	4360.9	357.3	10.29	388.2	55.3	3.07	396.2	89.7
24WF, B24b	2449	4121	4376.1	358.6	10.31	414.5	59.1	3.17	397.0	98.4
24WF, CB243	2368	4708	4376.1	358.6	10.31	414.5	59.1	3.17	397.0	98.4
CB244	2385	4556	4380.4	359.2	10.32	453.1	64.5	3.32	396.3	98.6
G24a	2817	2363	4201.4	350.1	10.10	346.9	53.4	2.90	392.8	86.0
CB244N	2379	4661	4360.0	357.3	10.29	447.1	63.7	3.30	394.8	97.5
G24a	2717	2734	4201.3	350.1	10.11	355.6	53.7	2.94	388.9	86.4
G24a	2921	1985	4241.9	353.5	10.17	338.3	52.0	2.87	395.8	85.4
G24a	2606	3247	3912.4	327.7	10.05	330.7	50.0	2.92	367.0	80.8
G24a	2581	3350	3939.6	329.9	10.07	329.9	50.0	2.92	365.6	80.6
CB244	2224	5986	4045.1	333.6	10.29	417.5	59.6	3.31	366.8	91.1
G24a	2379	4699	3993.1	329.3	10.22	348.9	49.8	3.02	364.5	81.2
24WF, B24B	2289	5426	4009.5	330.7	10.24	375.2	53.6	3.13	365.4	90.0
24WF, CB243	2204	6319	4009.5	330.7	10.24	375.2	53.6	3.13	365.4	90.0
CB244N	2216	6214	3999.3	329.8	10.23	408.4	58.3	3.27	363.6	89.2
G24	2636	3176	3844.8	318.8	10.09	278.2	45.3	2.72	358.5	72.9
G24	2610	3273	3867.1	320.7	10.12	277.5	45.2	2.71	357.0	72.7
G24	2487	3971	3585.3	298.8	10.08	256.9	41.9	2.70	335.0	67.6
G24	2567	3461	3607.3	300.6	10.10	349.4	41.6	2.66	336.8	67.0
G24	2462	4096	3607.8	300.6	10.10	256.3	41.9	2.69	333.5	67.4
G24	2426	4522	3632.9	298.9	10.14	240.6	39.8	2.61	333.2	64.4
G24	2651	2986	3630.7	302.6	10.14	240.0	40.0	2.61	338.2	65.8
CB243	2308	5390	3669.7	301.9	10.20	277.8	46.0	2.81	333.9	70.5
24WF, CB242	2287	5694	3635.3	299.1	10.15	254.0	42.0	2.68	332.9	69.7
24WF, B24a	2344	5159	3635.3	299.1	10.15	254.0	42.0	2.68	332.9	69.7
CB243N	2297	5609	3630.6	298.7	10.14	271.9	45.0	2.78	331.2	69.1
G24	2351	4962	3340.6	279.8	10.04	236.7	38.7	2.67	313.1	62.6
G24	2326	5131	3363.3	281.7	10.07	236.1	38.7	2.67	311.7	62.4
24WF, B24a	2168	6996	3315.0	274.4	10.12	229.1	38.0	2.66	304.2	63.5
24WF, CB242	2108	7829	3315.0	274.4	10.12	229.1	38.0	2.66	304.2	63.5
CB243N	2119	7695	3310.2	274.0	10.12	246.9	41.0	2.76	302.5	62.9
CB243	2127	7410	3343.5	276.8	10.17	252.2	41.9	2.79	304.8	64.1
G24	2243	6130	3307.8	273.8	10.11	215.6	35.8	2.58	303.9	58.1
G24	2238	6073	3184.3	267.8	10.00	220.6	36.2	2.63	296.4	58.6
G24	2225	6164	3173.1	266.9	10.02	220.0	36.1	2.64	295.0	58.5
B24b	2481	4462	2997.3	248.8	9.85	132.9	27.2	2.07	280.8	44.0
G24b	2495	4376	2967.7	246.4	9.84	132.9	27.2	2.08	280.8	44.0
G24	2066	8519	2982.5	248.5	10.06	190.3	31.7	2.54	275.0	51.7
24WF, B24a	1991	9822	2987.3	248.9	10.08	203.5	33.9	2.63	275.0	57.0
24WF, CB242	1927	11207	2987.3	248.9	10.08	203.5	33.9	2.63	275.0	57.0
CB243	1946	10499	3020.5	251.7	10.14	226.9	37.8	2.78	275.8	57.8
CB243N	1937	10991	2981.4	248.4	10.07	221.2	36.9	2.74	273.1	56.5
B24b	2372	5319	2841.3	236.8	9.83	124.9	25.6	2.06	266.7	41.4
B24b	2388	5207	2811.7	234.3	9.82	124.8	25.6	2.07	266.7	41.4
B24b	2273	6330	2692.7	225.2	9.80	117.1	24.1	2.04	253.3	39.0
B24b	2287	6196	2663.1	222.8	9.79	117.1	24.1	2.05	253.3	39.0
CB242	2052	9616	2734.9	225.0	9.95	130.2	26.4	2.17	253.1	41.0
24WF, CB241	2187	7680	2683.0	220.9	9.85	102.2	22.6	1.92	250.6	37.3
24WF, B24	2223	7196	2683.0	220.9	9.85	102.2	22.6	1.92	250.6	37.3
B24a	2116	8389	2716.7	224.0	9.96	120.1	23.9	2.09	251.6	38.9
CB242N	2002	10387	2725.4	224.7	9.98	136.5	27.2	2.23	252.2	42.1
B24a	2144	8000	2588.2	214.6	9.89	104.9	22.1	1.99	241.4	35.8
24WF, B24	2070	9534	2467.8	204.3	9.82	92.9	20.6	1.91	231.1	34.2
24WF, CB241	2032	10263	2467.8	204.3	9.82	92.9	20.6	1.91	231.1	34.2
B24a	1951	11556	2464.3	204.3	9.93	106.9	21.4	2.07	228.8	34.8
CB242	1865	13998	2457.2	203.5	9.92	116.2	23.7	2.16	227.8	36.7
CB242N	1834	14885	2454.6	203.7	9.91	121.9	24.4	2.21	228.3	37.6
B24a	2029	10115	2405.7	200.5	9.82	95.8	20.2	1.96	225.5	32.8
B24a	2098	8898	2381.9	198.5	9.80	91.1	19.7	1.92	225.8	32.1
B24a	2043	9894	2380.1	198.3	9.81	95.8	20.2	1.97	225.5	32.8
B24a	2098	8898	2381.9	198.5	9.80	91.1	19.7	1.92	225.8	32.1
B24a	2229	6891	2391.6	199.3	9.82	82.0	18.5	1.82	226.6	30.6
24WF, B24	2003	10956	2364.3	196.3	9.78	88.3	19.6	1.89	222.0	32.6
24WF, CB241	1964	11861	2364.3	196.3	9.78	88.3	19.6	1.89	222.0	32.6
B24	2071	10481	2240.9	186.7	9.55	78.0	17.1	1.78	215.9	28.5
B24	2143	8925	2240.3	186.7	9.60	71.1	16.1	1.71	215.3	27.3
B24	1979	11529	2288.4	189.8	9.79	80.9	17.9	1.84	214.6	29.2
CB241N	1882	14043	2292.6	190.1	9.81	91.3	20.2	1.96	214.5	31.4
24WF, CB241	1873	14457	2229.7	185.8	9.73	82.4	18.3	1.87	210.1	30.6
24WF, B24	1915	13246	2229.7	185.8	9.73	82.4	18.3	1.87	210.1	30.6

Table 2.3.1 Dimensions and Primary Properties -- Steel Sections 1887-1952

Designation	Source Reference Number	Wt. per ft lb	Area	Depth	Web Thickness	Flange Width	Average Flange Thickness	Distance	Distance	Compact Section Criteria		
			A in.2	d in.	t _w in.	b _f in.	t _f in.	T in.	k in.	b _f /2t _f	h/t _w	F _y " ksi
B24	10	79.5	23.35	24.09	0.430	9.035	0.745	21.281	1.405	6.07	49.5	26
B24	8	79.5	23.17	24.09	0.430	9.035	0.745	21.281	1.405	6.07	49.5	26
24WF, B24	15	76.0	22.37	23.91	0.440	8.985	0.682	21.585	1.163	6.59	49.1	27
24WF, CB241	23	76.0	22.37	23.91	0.440	8.985	0.682	21.341	1.285	6.59	48.5	27
CB242	19	76.0	22.35	24.00	0.405	9.750	0.663	21.349	1.326	7.35	52.7	23
B62	18	74.2	21.70	24.00	0.476	9.000	0.594	21.599	1.201	7.58	45.4	31
B24	11	74.0	21.81	24.00	0.415	9.000	0.680	21.321	1.340	6.62	51.4	24
CB241N	20	74.0	21.77	24.00	0.412	9.000	0.680	21.415	1.293	6.62	52.0	24
24WF, CB241	21	74.0	21.77	23.87	0.430	8.975	0.662	21.341	1.265	6.78	49.6	26
24WF, B24	12	74.0	21.77	23.87	0.430	8.975	0.662	21.585	1.143	6.78	50.2	26
B62	17	74.0	21.70	24.00	0.476	9.000	0.594	21.599	1.201	7.58	45.4	31
B24	10	73.5	21.70	24.00	0.395	9.000	0.700	21.281	1.360	6.43	53.9	22
B24	8	73.5	21.52	24.00	0.395	9.000	0.700	21.281	1.360	6.43	53.9	22
B24	3	73.5	21.47	24.00	0.390	9.000	0.704	21.245	1.378	6.40	54.5	22
B24	1	72.0	21.21	24.00	0.370	8.700	0.741	21.087	1.456	5.87	57.0	20
B20	24	71.0	20.88	24.00	0.480	7.000	0.685	21.292	1.354	5.11	44.4	33
B24	11	70.0	20.61	23.88	0.410	8.995	0.620	21.321	1.280	7.25	52.0	24
CB241N	20	70.0	20.59	23.88	0.408	8.996	0.620	21.415	1.233	7.25	52.5	23
CB241	19	70.0	20.58	24.00	0.400	8.500	0.663	21.349	1.326	6.41	53.4	23
B24	10	70.0	20.62	23.88	0.395	9.000	0.640	21.281	1.300	7.04	53.9	22
B32	16	69.5	20.44	24.00	0.390	7.000	0.816	20.690	1.655	4.29	53.1	23
G22	6	132.0	38.96	22.38	0.575	13.095	1.030	18.586	1.897	6.36	32.3	62
G22	5	124.0	36.59	22.25	0.545	13.065	0.965	18.586	1.832	6.77	34.1	55
G22	7	116.0	34.13	22.12	0.535	13.035	0.880	18.628	1.746	7.41	34.8	53
G22	5	116.0	34.12	22.12	0.510	13.030	0.900	18.586	1.767	7.24	36.4	48
G22	5	108.0	31.89	22.00	0.480	13.000	0.840	18.586	1.707	7.74	38.7	43
G22	7	108.0	31.89	22.00	0.500	13.000	0.820	18.628	1.686	7.93	37.3	46
G22	7	101.0	29.69	21.88	0.475	12.975	0.760	18.628	1.626	8.54	39.2	42
G22	5	101.0	29.68	21.88	0.450	12.970	0.780	18.586	1.647	8.31	41.3	38
B22a	3	96.5	28.38	22.25	0.525	9.320	0.937	18.965	1.642	4.97	36.1	49
B22a	7	96.0	28.21	22.25	0.545	9.315	0.905	19.029	1.610	5.15	34.9	53
B22a	3	89.0	26.28	22.12	0.485	9.280	0.872	18.965	1.577	5.32	39.1	42
B22a	7	89.0	26.23	22.12	0.510	9.280	0.840	19.029	1.545	5.52	37.3	46
B22a	3	83.0	24.51	22.00	0.455	9.250	0.812	18.965	1.517	5.70	41.7	37
B22a	7	83.0	24.45	22.00	0.480	9.250	0.780	19.029	1.485	5.93	39.6	41
B22a	3	77.0	22.74	21.88	0.425	9.220	0.752	18.965	1.457	6.13	44.6	32
B22a	7	77.0	22.67	21.89	0.445	9.215	0.725	19.029	1.430	6.36	42.8	35
B22	7	73.0	21.52	22.38	0.435	8.555	0.715	19.651	1.365	5.98	45.2	32
B22	4	73.0	21.51	22.25	0.415	8.545	0.744	19.463	1.394	5.74	46.9	29
B22	1	71.5	20.88	22.12	0.420	8.535	0.714	19.393	1.364	5.98	46.2	30
B22	1	68.5	20.04	22.06	0.405	8.520	0.684	19.393	1.334	6.23	47.9	28
B22	4	67.5	19.84	22.12	0.390	8.520	0.679	19.463	1.329	6.27	49.9	26
B22	7	67.0	19.74	22.25	0.405	8.525	0.650	19.651	1.300	6.56	48.5	27
B22	1	65.5	19.08	22.00	0.385	8.500	0.654	19.393	1.304	6.50	50.4	25
B22	4	62.5	18.38	22.00	0.370	8.500	0.619	19.463	1.269	6.87	52.6	23
B22	7	62.0	18.19	22.12	0.385	8.505	0.585	19.651	1.235	7.27	51.0	25
B22	4	58.0	17.14	21.88	0.360	8.490	0.559	19.463	1.209	7.59	54.1	22
B22	2	58.0	17.10	21.81	0.360	8.475	0.559	19.393	1.209	7.58	53.9	22
B22	7	58.0	17.06	22.00	0.380	8.500	0.525	19.651	1.175	8.10	51.7	24
B22	6	54.5	16.04	21.75	0.360	8.490	0.494	19.463	1.144	8.59	54.1	22
21WF, B21b	2	142.0	41.76	21.46	0.659	13.132	1.095	18.058	1.701	6.00	27.4	-
21WF, CB213	12	142.0	41.76	21.46	0.659	13.132	1.095	17.845	1.808	6.00	27.1	-
CB213	9	136.0	40.00	21.49	0.606	13.141	1.061	17.745	1.874	6.19	29.3	-
21WF, CB213	11	132.0	38.81	21.31	0.614	13.087	1.020	17.845	1.733	6.42	29.1	-
21WF, B21b	1	132.0	38.81	21.31	0.614	13.087	1.020	18.058	1.626	6.42	29.4	-
CB213	9	128.0	37.65	21.37	0.570	13.105	1.001	17.745	1.814	6.55	31.1	-
21WF, CB213	13	127.0	37.34	21.24	0.588	13.061	0.985	17.845	1.698	6.63	30.3	-
21WF, B21b	3	127.0	37.34	21.24	0.588	13.061	0.985	18.058	1.591	6.63	30.7	-
21WF, B21b	1	122.0	35.85	21.16	0.567	13.040	0.945	18.058	1.551	6.90	31.8	63
21WF, CB213	11	122.0	35.85	21.16	0.567	13.040	0.945	17.845	1.658	6.90	31.5	65
CB213	8	120.0	35.28	21.25	0.535	13.070	0.939	17.745	1.752	6.96	33.2	59
CB213N	10	116.0	34.12	21.26	0.507	13.057	0.915	17.809	1.728	7.13	35.1	52
CB213	8	112.0	32.93	21.13	0.499	13.034	0.878	17.745	1.691	7.42	35.6	51
21WF, CB213	12	112.0	32.93	21.00	0.527	13.000	0.865	17.845	1.578	7.51	33.9	56
21WF, B21b	2	112.0	32.93	21.00	0.527	13.000	0.865	18.058	1.471	7.51	34.3	55
CB213N	10	108.0	31.76	21.14	0.473	13.023	0.852	17.809	1.665	7.64	37.7	45
CB213	8	104.0	30.57	21.00	0.465	13.000	0.815	17.745	1.628	7.98	38.2	44
21WF, CB212	11	103.0	30.27	21.29	0.608	9.071	1.010	17.845	1.723	4.49	29.4	-
21WF, B21a	1	103.0	30.27	21.29	0.608	9.071	1.010	18.225	1.532	4.49	30.0	-
CB213N	10	101.0	29.69	21.02	0.450	13.000	0.791	17.809	1.604	8.22	39.6	41
CB212	9	98.0	28.82	21.36	0.535	9.097	0.994	17.745	1.807	4.58	33.2	59
CB212N	10	96.0	28.24	21.38	0.524	9.104	0.971	17.809	1.784	4.69	34.0	56
21WF, CB212	12	96.0	28.21	21.14	0.575	9.038	0.935	17.845	1.648	4.83	31.0	-
21WF, B21a	2	96.0	28.21	21.14	0.575	9.038	0.935	18.225	1.457	4.83	31.7	64
CB213	8	92.0	27.05	21.24	0.502	9.064	0.935	17.745	1.748	4.85	35.3	52

Table 2.3.1 Dimensions and Primary Properties – Steel Sections 1887-1952

Designation	X ₁ ksi	X ₂ x 106 (1/ksi) ²	Elastic Properties						Plastic Modulus	
			Axis x-x			Axis y-y			Z _x in.3	Z _y in.3
			I _x	S _x	r _x	I _y	S _y	r _y		
			in.4	in.3	in.	in.4	in.3	in.		
B24	1950	11874	2266.7	188.2	9.85	81.2	18.0	1.87	211.9	29.2
B24	1962	11648	2245.3	186.4	9.84	81.2	18.0	1.87	211.9	29.2
24WF, B24	1826	16159	2096.4	175.4	9.68	76.5	17.0	1.85	198.3	28.6
24WF, CB241	1783	17800	2096.4	175.4	9.68	76.5	17.0	1.85	198.3	28.6
CB242	1679	21171	2184.4	182.0	9.89	102.6	21.0	2.14	202.9	32.4
B62	1812	18571	1950.1	162.5	9.48	61.2	13.6	1.68	186.9	23.0
B24	1827	15748	2085.3	173.8	9.78	72.4	16.1	1.82	195.8	26.3
CB241N	1728	19562	2088.3	174.0	9.79	82.8	18.4	1.95	195.5	28.5
24WF, CB241	1737	19757	2033.8	170.4	9.67	73.8	16.5	1.84	192.5	27.7
24WF, B24	1782	17854	2033.8	170.4	9.67	73.8	16.5	1.84	192.5	27.7
B62	1812	18571	1950.1	162.5	9.48	61.2	13.6	1.68	186.9	23.0
B24	1830	15136	2108.8	175.7	9.86	74.7	16.6	1.86	197.0	27.0
B24	1841	14827	2087.4	173.9	9.85	74.7	16.6	1.86	197.0	27.0
B24	1849	14416	2091.0	174.3	9.87	74.4	16.5	1.86	197.2	27.0
B24	1939	11620	2090.5	174.2	9.93	67.7	15.6	1.79	196.6	25.8
B20	2031	12479	1815.0	151.2	9.32	34.0	9.7	1.26	173.2	16.6
B24	1733	20082	1924.9	161.2	9.66	65.0	14.5	1.78	182.2	23.8
CB241N	1633	25278	1929.1	161.6	9.68	75.4	16.8	1.91	182.0	26.0
CB241	1707	20983	1953.8	162.8	9.74	68.0	16.0	1.82	182.9	24.9
B24	1738	19237	1954.1	163.7	9.74	67.4	15.0	1.81	184.1	24.6
B32	2156	8240	1928.0	160.7	9.71	39.3	11.2	1.39	181.0	18.8
G22	2847	2202	3501.2	312.9	9.48	339.3	51.8	2.95	347.0	83.2
G22	2692	2752	3261.7	293.2	9.44	312.6	47.9	2.92	324.3	77.1
G22	2522	3646	2988.1	270.2	9.36	279.1	42.8	2.86	298.8	69.4
G22	2531	3505	3021.2	273.2	9.41	286.0	43.9	2.90	301.2	70.9
G22	2386	4425	2804.3	254.9	9.38	261.9	40.3	2.87	280.3	65.3
G22	2375	4643	2766.7	251.5	9.33	254.7	39.2	2.83	277.3	63.8
G22	2235	5908	2557.2	233.7	9.28	231.3	35.7	2.79	257.2	58.4
G22	2242	5669	2590.4	236.8	9.34	238.1	36.7	2.83	259.6	59.8
B22a	2632	3429	2373.7	213.4	9.15	115.1	24.7	2.01	240.5	39.7
B22a	2601	3702	2328.5	209.3	9.08	110.7	23.8	1.98	236.8	38.4
B22a	2457	4477	2188.6	197.9	9.13	104.8	22.6	2.00	222.2	36.4
B22a	2435	4815	2147.9	194.2	9.05	100.7	21.7	1.96	219.1	35.2
B22a	2306	5754	2026.5	184.2	9.09	95.8	20.7	1.98	206.3	33.4
B22a	2285	6211	1985.8	180.5	9.01	91.7	19.8	1.94	203.1	32.2
B22a	2155	7525	1866.7	170.6	9.06	87.0	18.9	1.96	190.5	30.5
B22a	2136	8089	1832.7	167.4	8.99	83.4	18.1	1.92	187.8	29.4
B22	2056	9775	1786.1	159.6	9.11	66.4	15.5	1.76	180.2	25.3
B22	2089	8826	1796.7	161.5	9.14	69.1	16.2	1.79	181.4	26.2
B22	2065	9460	1705.2	154.2	9.04	65.8	15.4	1.78	175.3	25.1
B22	1991	10957	1629.3	147.7	9.02	62.3	14.6	1.76	167.8	23.8
B22	1938	11976	1637.5	148.1	9.08	61.8	14.5	1.76	166.0	23.6
B22	1901	13439	1620.2	145.6	9.06	59.0	13.8	1.73	164.1	22.6
B22	1908	12924	1549.5	140.9	9.01	58.8	13.8	1.76	159.8	22.5
B22	1807	16054	1495.4	135.9	9.02	55.2	13.0	1.73	152.3	21.2
B22	1766	18420	1465.7	132.5	8.98	51.8	12.2	1.69	149.3	20.1
B22	1694	21371	1363.9	124.7	8.92	48.9	11.5	1.69	139.9	19.0
B22	1700	21081	1352.1	124.0	8.89	48.6	11.5	1.69	139.1	18.9
B22	1669	23941	1337.1	121.6	8.85	45.6	10.7	1.63	137.5	17.9
B22	1601	28236	1232.6	113.3	8.77	42.2	10.0	1.62	127.9	16.6
21WF, B21b	3117	1561	3403.1	317.2	9.03	385.9	58.8	3.04	354.0	96.5
21WF, CB213	3037	1729	3403.1	317.2	9.03	385.9	58.8	3.04	354.0	96.5
CB213	2912	2001	3313.7	308.4	9.10	401.7	61.1	3.17	341.7	93.4
21WF, CB213	2836	2260	3141.6	294.8	9.00	353.8	54.1	3.02	327.8	89.2
21WF, B21b	2917	2017	3141.6	294.8	9.00	353.8	54.1	3.02	327.8	89.2
CB213	2751	2493	3103.4	290.4	9.08	375.9	57.4	3.16	320.7	87.5
21WF, CB213	2734	2596	3017.2	284.1	8.99	338.6	51.8	3.01	315.2	85.7
21WF, B21b	2817	2304	3017.2	284.1	8.99	338.6	51.8	3.01	315.2	85.7
21WF, B21b	2715	2665	2883.2	272.5	8.97	322.1	49.4	3.00	301.7	81.9
21WF, CB213	2630	3026	2883.2	272.5	8.97	322.1	49.4	3.00	301.7	81.9
CB213	2588	3166	2890.9	272.1	9.05	349.7	53.5	3.15	299.4	81.6
CB213N	2500	3596	2819.7	265.2	9.09	339.7	52.0	3.16	291.0	79.2
CB213	2425	4078	2683.7	254.1	9.03	324.3	49.8	3.14	278.5	75.8
21WF, CB213	2425	4182	2620.6	249.6	8.92	289.7	44.6	2.96	275.3	74.4
21WF, B21b	2514	3616	2620.6	249.6	8.92	289.7	44.6	2.96	275.3	74.4
CB213N	2336	4689	2608.0	246.8	9.06	313.9	48.2	3.14	269.7	73.3
CB213	2262	5366	2475.3	235.7	9.00	298.7	45.9	3.13	257.5	69.9
21WF, CB212	2952	2239	2268.0	213.1	8.66	119.9	26.4	1.99	242.2	43.3
21WF, B21a	2973	2174	2268.0	213.1	8.66	119.9	26.4	1.99	242.2	43.3
CB213N	2190	6089	2413.8	229.7	9.02	289.8	44.6	3.12	250.5	67.8
CB212	2814	2569	2234.5	209.2	8.80	125.0	27.5	2.08	234.3	42.5
CB212N	2746	2834	2196.5	205.5	8.82	122.4	26.9	2.08	229.9	41.6
21WF, CB212	2763	2923	2088.9	197.6	8.60	109.3	24.2	1.97	224.1	39.8
21WF, B21a	2787	2823	2088.9	197.6	8.60	109.3	24.2	1.97	224.1	39.8
CB213	2653	3228	2086.4	196.5	8.78	116.3	25.7	2.07	219.2	39.6

Table 2.3.1 Dimensions and Primary Properties -- Steel Sections 1887-1952

Designation	Source Reference Number	Wt. per ft lb	Area	Depth	Web Thickness	Flange Width	Average Flange Thickness	Distance	Distance	Compact Section Criteria		
			A in.2	d in.	t _w in.	b _f in.	t _f in.	T in.	k in.	b _f /2t _f	h/t _w	F _y ^m ksi
CB212N	10	89.0	26.17	21.24	0.485	9.065	0.903	17.809	1.716	5.02	36.7	48
21WF, CB212	11	89.0	26.15	21.00	0.537	9.000	0.865	17.845	1.578	5.20	33.2	58
21WF, CB21a	1	89.0	26.15	21.00	0.537	9.000	0.865	18.225	1.387	5.20	33.9	56
CB212	8	86.0	25.28	21.12	0.470	9.032	0.875	17.745	1.688	5.16	37.8	45
CB212N	10	83.0	24.41	21.12	0.452	9.032	0.844	17.809	1.657	5.35	39.4	41
21WF, CB212	12	82.0	24.10	20.86	0.499	8.962	0.795	17.845	1.508	5.64	35.8	50
21WF, B21a	2	82.0	24.10	20.86	0.499	8.962	0.795	18.225	1.317	5.64	36.5	48
CB212	8	80.0	23.53	21.00	0.438	9.000	0.815	17.745	1.628	5.52	40.5	39
CB212N	10	77.0	22.63	21.00	0.420	9.000	0.783	17.809	1.596	5.75	42.4	36
CB211	9	76.0	22.34	21.37	0.469	8.109	0.793	18.559	1.406	5.11	39.6	41
B21	14	75.0	22.05	21.00	0.520	7.000	0.820	17.966	1.517	4.27	34.5	54
CB211N	10	73.0	21.46	21.33	0.427	8.327	0.769	18.571	1.382	5.41	43.5	34
21WF, CB211	12	73.0	21.46	21.24	0.455	8.295	0.740	18.555	1.343	5.60	40.8	39
21WF, B21a	2	73.0	21.46	21.24	0.455	8.295	0.740	18.799	1.221	5.60	41.3	38
CB211	8	70.0	20.59	21.25	0.433	8.073	0.732	18.559	1.345	5.51	42.9	35
21WF, CB211	12	68.0	20.02	21.13	0.430	8.270	0.685	18.555	1.288	6.04	43.2	35
21WF, B21	2	68.0	20.02	21.13	0.430	8.270	0.685	18.799	1.166	6.04	43.7	34
CB211N	10	67.0	19.71	21.21	0.393	8.293	0.707	18.571	1.320	5.86	47.3	29
CB211	8	64.0	18.82	21.13	0.396	8.036	0.671	18.559	1.284	5.99	46.9	29
21WF, CB211	11	63.0	18.52	21.00	0.410	8.250	0.620	18.555	1.223	6.65	45.3	31
21WF	1	63.0	18.52	21.00	0.410	8.250	0.620	18.799	1.101	6.65	45.9	31
CB211N	10	62.0	18.23	21.10	0.367	8.267	0.651	18.571	1.264	6.35	50.6	25
21WF, CB211	13	62.0	18.23	20.99	0.400	8.240	0.615	18.555	1.218	6.70	46.4	30
21WF, CB21	3	62.0	18.23	20.99	0.400	8.240	0.615	18.799	1.096	6.70	47.0	29
B63	5	60.5	17.68	21.00	0.428	8.250	0.548	18.790	1.105	7.53	43.9	33
B63	6	60.4	17.68	21.00	0.428	8.250	0.548	18.790	1.105	7.53	43.9	33
CB211	7	60.0	17.64	21.03	0.375	8.015	0.625	18.559	1.238	6.41	49.5	26
21WF, CB211	11	59.0	17.36	20.91	0.390	8.230	0.575	18.555	1.178	7.16	47.6	28
21WF, B21	1	59.0	17.36	20.91	0.390	8.230	0.575	18.799	1.056	7.16	48.2	28
CB211N	10	58.0	17.06	21.00	0.350	8.250	0.602	18.571	1.215	6.85	53.1	23
CB211	8	58.0	17.05	21.00	0.360	8.000	0.608	18.559	1.221	6.58	51.6	24
B22	14	58.0	16.90	21.00	0.430	6.500	0.620	18.536	1.232	5.24	43.1	35
B33	4	57.5	16.85	21.00	0.357	6.500	0.740	17.963	1.518	4.39	50.3	25
CB211	9	55.0	16.17	20.89	0.360	8.000	0.553	18.559	1.166	7.23	51.6	24
----		55.0	16.18	20.80	0.375	8.215	0.522	18.551	1.125	7.87	49.5	26
G20a	9	149.0	43.84	20.12	0.690	12.780	1.223	15.793	2.164	5.23	22.9	-
G20a	5	149.0	43.44	20.12	0.690	12.780	1.223	15.791	2.165	5.23	22.9	-
G20	10	146.0	42.97	20.38	0.710	12.080	1.240	16.214	2.083	4.87	22.8	-
CB203N	11	146.0	42.95	20.38	0.710	12.080	1.240	16.475	1.953	4.87	23.2	-
G20a	9	142.0	41.71	20.00	0.660	12.750	1.163	15.793	2.104	5.48	23.9	-
G20a	5	142.0	41.31	20.00	0.660	12.750	1.163	15.791	2.105	5.48	23.9	-
G20a	1	140.0	41.28	20.00	0.640	12.500	1.201	15.446	2.277	5.21	24.1	-
G20a	2	140.0	41.19	20.00	0.640	12.500	1.197	15.693	2.154	5.22	24.5	-
G20	10	135.0	39.74	20.18	0.670	12.040	1.140	16.214	1.983	5.28	24.2	-
CB203N	11	135.0	39.71	20.18	0.669	12.039	1.140	16.475	1.853	5.28	24.6	-
G20a	9	135.0	39.58	19.88	0.630	12.720	1.103	15.793	2.044	5.77	25.1	-
G20a	5	135.0	39.18	19.88	0.630	12.720	1.103	15.791	2.045	5.77	25.1	-
G20a	8	127.0	37.33	19.75	0.600	12.690	1.038	15.793	1.979	6.12	26.3	-
G20	10	125.0	36.77	20.00	0.630	12.000	1.050	16.214	1.893	5.71	25.7	-
CB203N	11	125.0	36.76	20.00	0.650	12.000	1.050	16.475	1.763	5.71	25.3	-
G20	9	120.0	35.24	20.12	0.590	12.030	1.009	16.414	1.853	5.96	27.8	-
G20	5	120.0	34.95	20.12	0.590	12.030	1.009	16.414	1.853	5.96	27.8	-
CB203N	11	115.0	33.83	19.82	0.591	11.961	0.960	16.475	1.673	6.23	27.9	-
G20	10	115.0	33.82	19.82	0.590	11.960	0.960	16.214	1.803	6.23	27.5	-
G20	9	113.0	33.20	20.00	0.560	12.000	0.949	16.414	1.793	6.33	29.3	-
G20	5	113.0	32.90	20.00	0.560	12.000	0.949	16.414	1.793	6.33	29.3	-
G20	1	112.0	32.88	20.00	0.520	12.000	0.979	16.112	1.944	6.13	31.0	-
G20	2	112.0	32.81	20.00	0.550	12.000	0.953	16.368	1.816	6.30	29.8	-
G20	9	107.0	31.36	19.88	0.540	11.980	0.889	16.414	1.733	6.74	30.4	-
G20	5	107.0	31.06	19.88	0.540	11.980	0.889	16.414	1.733	6.74	30.4	-
G20	8	99.0	29.21	19.75	0.510	11.950	0.824	16.414	1.668	7.26	32.2	62
B20a	10	98.0	28.89	20.38	0.580	9.095	0.990	17.001	1.689	4.59	29.3	-
CB202N	11	98.0	28.82	20.38	0.577	9.092	0.990	17.175	1.603	4.59	29.8	-
CB202N	11	88.0	25.87	20.18	0.521	9.036	0.890	17.175	1.503	5.08	33.0	59
B20A	10	88.0	25.86	20.18	0.520	9.035	0.890	17.001	1.589	5.08	32.7	60
B20a	1	82.0	24.23	20.00	0.570	8.510	0.808	16.877	1.562	5.27	29.6	-
B20a	3	82.0	24.17	20.00	0.570	8.890	0.768	17.045	1.477	5.79	29.9	-
B20a	10	80.0	23.54	20.00	0.485	9.000	0.800	17.001	1.499	5.63	35.1	52
CB202N	11	80.0	23.53	20.00	0.485	9.000	0.800	17.175	1.413	5.63	35.4	51
B20a	6	78.0	22.77	20.09	0.460	8.905	0.801	17.175	1.458	5.56	37.3	46
CB202N	11	74.0	21.77	19.88	0.451	8.966	0.740	17.175	1.353	6.06	38.1	44
B20a	10	74.0	21.76	19.88	0.450	8.965	0.740	17.001	1.439	6.06	37.8	45
B20a	6	73.0	21.37	20.00	0.430	8.875	0.756	17.091	1.454	5.87	39.7	41
B20a	4	73.0	21.37	20.00	0.430	8.750	0.768	17.045	1.477	5.70	39.6	41

Table 2.3.1 Dimensions and Primary Properties – Steel Sections 1887-1952

Designation	X ₁ ksi	X ₂ x 106 (1/ksi)2	Elastic Properties						Plastic Modulus	
			Axis x-x			Axis y-y			Z _x in.3	Z _y in.3
			I _x	S _x	r _x	I _y	S _y	r _y		
			in.4	in.3	in.	in.4	in.3	in.		
CB212N	2560	3717	2024.9	190.7	8.80	112.4	24.8	2.07	212.3	38.2
21WF, CB212	2573	3874	1919.2	182.8	8.57	99.4	22.1	1.95	206.6	36.4
21WF, CB21a	2600	3719	1919.2	182.8	8.57	99.4	22.1	1.95	206.6	36.4
CB212	2494	4114	1939.3	183.6	8.76	107.7	23.8	2.06	204.1	36.8
CB212N	2401	4770	1879.0	177.9	8.77	103.9	23.0	2.06	197.3	35.4
21WF, CB212	2385	5246	1752.4	168.0	8.53	89.6	20.0	1.93	189.3	33.1
21WF, B21a	2414	4999	1752.4	168.0	8.53	89.6	20.0	1.93	189.3	33.1
CB212	2333	5336	1794.4	170.9	8.73	99.2	22.0	2.05	189.1	33.9
CB212N	2239	6270	1732.1	165.0	8.75	95.3	21.2	2.05	182.1	32.6
CB211	2275	6504	1684.0	157.6	8.68	70.7	17.4	1.78	178.2	27.2
B21	2632	4016	1524.0	145.1	8.32	41.9	12.0	1.38	164.5	20.0
CB211N	2152	7777	1650.1	154.7	8.77	74.2	17.8	1.86	173.5	27.6
21WF, CB211	2152	8133	1600.3	150.7	8.64	66.2	16.0	1.76	170.2	26.5
21WF, B21a	2195	7524	1600.3	150.7	8.64	66.2	16.0	1.76	170.2	26.5
CB211	2107	8793	1542.9	145.2	8.66	64.3	15.9	1.77	163.6	24.8
21WF, CB211	2015	10641	1478.3	139.9	8.59	60.4	14.6	1.74	157.8	24.3
21WF, B21	2060	9742	1478.3	139.9	8.59	60.4	14.6	1.74	157.8	24.3
CB211N	1986	10659	1506.2	142.0	8.74	67.3	16.2	1.85	158.7	25.1
CB211	1936	12241	1403.3	132.9	8.64	58.2	14.5	1.76	149.0	22.4
21WF, CB211	1869	14593	1343.6	128.0	8.52	53.8	13.0	1.70	144.3	21.9
21WF	1918	13160	1343.6	128.0	8.52	53.8	13.0	1.70	144.3	21.9
CB211N	1843	14370	1382.0	131.0	8.71	61.4	14.9	1.84	146.0	22.9
21WF, CB211	1843	15337	1326.8	126.4	8.53	53.1	12.9	1.71	142.3	21.7
21WF, CB21	1892	13811	1326.8	126.4	8.53	53.1	12.9	1.71	142.3	21.7
B63	1872	15736	1235.5	117.7	8.36	43.5	10.6	1.57	134.7	17.7
B63	1872	15736	1235.5	117.7	8.36	43.5	10.6	1.57	134.7	17.7
CB211	1820	15717	1304.9	124.1	8.60	43.7	13.4	1.75	138.9	20.8
21WF, CB211	1758	18763	1246.8	119.3	8.47	49.2	12.0	1.68	134.3	20.2
21WF, B21	1810	16706	1246.8	119.3	8.47	49.2	12.0	1.68	134.3	20.2
CB211N	1728	18751	1279.1	121.8	8.66	56.4	13.7	1.82	135.6	21.1
CB211	1765	17645	1263.2	120.3	8.61	52.0	13.0	1.75	134.4	20.1
B22	2078	10998	1143.0	108.8	8.22	24.5	7.5	1.20	124.0	12.8
B33	2244	6890	1227.5	116.9	8.54	28.4	8.8	1.30	131.3	14.6
CB211	1672	22700	1166.7	111.7	8.49	47.3	11.8	1.71	125.2	18.3
----	1647	24897	1140.7	109.7	8.40	44.0	10.7	1.65	123.5	18.3
G20a	3827	675	3134.9	311.6	8.46	384.6	60.2	2.96	348.9	95.8
G20a	3845	662	3106.6	308.8	8.46	384.5	60.2	2.97	348.9	95.8
G20	3834	690	3105.1	304.7	8.50	332.3	55.0	2.78	343.4	87.6
CB203N	3650	838	3108.8	305.1	8.51	364.9	60.4	2.91	343.6	92.7
G20a	3660	804	2960.6	296.1	8.43	361.0	56.6	2.94	330.5	90.3
G20a	3679	788	2932.3	293.2	8.43	360.9	56.6	2.96	330.5	90.3
G20a	3870	637	2938.3	293.8	8.44	334.3	53.5	2.85	331.1	86.9
G20a	3758	715	2934.7	293.5	8.44	348.9	55.8	2.91	330.7	89.1
G20	3571	917	2829.3	280.4	8.44	299.7	49.8	2.75	314.8	79.5
CB203N	3387	1129	2832.3	280.7	8.45	332.0	55.2	2.89	314.9	84.6
G20a	3493	965	2788.9	280.6	8.39	337.7	53.1	2.92	312.3	84.8
G20a	3512	945	2760.6	277.7	8.39	337.6	53.1	2.94	312.3	84.8
G20a	3316	1185	2607.3	264.0	8.36	313.0	49.3	2.90	293.0	79.0
G20	3329	1212	2584.0	258.4	8.38	270.6	45.1	2.71	289.0	72.3
CB203N	3172	1465	2587.7	258.8	8.39	302.8	50.5	2.87	290.8	77.5
G20	3154	1487	2528.0	251.3	8.47	260.2	43.3	2.72	280.0	69.3
G20	3168	1461	2505.5	249.1	8.47	260.1	43.2	2.73	280.0	69.3
CB203N	2907	2079	2348.3	237.0	8.33	274.2	45.8	2.85	263.9	70.2
G20	3089	1636	2343.9	236.5	8.32	242.1	40.5	2.68	263.6	65.1
G20	2990	1836	2362.8	236.3	8.44	240.8	40.1	2.69	262.5	64.5
G20	3006	1801	2340.2	234.0	8.43	240.8	40.1	2.71	262.5	64.5
G20	3146	1457	2368.9	236.9	8.49	232.8	38.8	2.66	265.3	63.8
G20	3018	1757	2342.1	234.2	8.45	239.3	39.9	2.70	262.5	64.3
G20	2841	2263	2206.5	222.0	8.39	222.4	37.1	2.66	246.2	59.9
G20	2857	2216	2184.0	219.7	8.39	222.3	37.1	2.68	246.2	59.9
G20	2669	2907	2034.4	206.0	8.35	202.1	33.8	2.63	227.8	54.8
B20a	3088	1816	2010.5	197.3	8.34	114.1	25.1	1.99	223.6	40.4
CB202N	2951	2168	2009.7	197.2	8.35	124.3	27.4	2.08	223.4	42.5
CB202N	2665	3232	1784.4	176.9	8.30	109.7	24.3	2.06	199.2	37.6
B20A	2793	2682	1782.4	176.7	8.30	99.4	22.0	1.96	199.0	35.4
B20a	2842	2785	1561.3	156.1	8.03	71.5	16.8	1.72	180.0	28.1
B20a	2699	3425	1559.8	156.0	8.03	79.9	18.0	1.82	179.7	29.7
B20a	2562	3815	1595.0	159.5	8.23	87.2	19.4	1.93	179.2	31.3
CB202N	2433	4681	1596.3	159.6	8.24	97.4	21.6	2.03	179.3	33.5
B20a	2514	4059	1568.3	156.1	8.30	84.6	19.0	1.93	176.8	30.6
CB202N	2260	6260	1466.7	147.6	8.21	89.1	19.9	2.02	165.2	30.7
B20a	2387	5033	1464.7	147.4	8.20	78.9	17.6	1.90	165.0	28.5
B20a	2392	4911	1467.8	146.8	8.29	78.5	17.7	1.92	165.8	28.5
B20a	2430	4608	1466.5	146.7	8.28	75.9	17.3	1.88	165.7	28.1

Table 2.3.1 Dimensions and Primary Properties -- Steel Sections 1887-1952

Designation	Source Reference Number	Wt. per ft lb	Area	Depth	Web Thickness	Flange Width	Average Flange Thickness	Distance	Distance	Compact Section Criteria		
			A	d	t _w	b _f	t _f	T	k	b _f /2t _f	h/t _w	F _y "
			in.2	in.	in.	in.	in.	in.	in.	in.		
B20a	1	72.0	21.43	20.00	0.430	8.370	0.808	16.877	1.562	5.18	39.2	42
B20a	2	72.0	21.37	20.00	0.430	8.750	0.768	17.045	1.477	5.70	39.6	41
B20	2	69.0	20.26	20.00	0.520	8.145	0.647	17.487	1.257	6.30	33.6	57
B20a	7	68.5	20.12	19.88	0.410	8.855	0.696	17.091	1.394	6.36	41.7	37
B20	1	68.0	19.95	20.00	0.490	7.690	0.705	17.263	1.369	5.45	35.2	52
CB20	11	65.0	19.12	20.25	0.416	8.046	0.690	17.745	1.253	5.83	42.7	35
B20	10	65.0	19.08	20.25	0.415	8.045	0.690	17.675	1.288	5.83	42.6	35
B20	4	64.5	18.86	20.00	0.450	8.075	0.647	17.487	1.257	6.25	38.9	43
B20	6	64.5	18.79	20.12	0.400	8.025	0.705	17.515	1.303	5.70	43.8	34
B20	2	64.0	18.86	20.00	0.450	8.075	0.647	17.487	1.257	6.25	38.9	43
B20	1	63.0	18.55	20.00	0.420	7.620	0.705	17.263	1.369	5.40	41.1	38
B20	6	62.0	18.11	20.06	0.390	8.015	0.675	17.515	1.273	5.94	44.9	32
CB201N	11	60.0	17.65	20.12	0.395	8.025	0.625	17.745	1.188	6.42	44.9	32
B20	1	60.0	17.65	20.00	0.375	7.580	0.705	17.263	1.369	5.38	46.0	30
B20	10	60.0	17.63	20.12	0.395	8.025	0.625	17.675	1.223	6.42	44.7	32
B20	4	59.5	17.36	20.00	0.375	8.000	0.647	17.487	1.257	6.19	46.6	30
B20	6	59.5	17.33	20.00	0.375	8.000	0.645	17.515	1.243	6.21	46.7	30
B20	2	59.0	17.36	20.00	0.375	8.000	0.647	17.487	1.257	6.19	46.6	30
B20	1	58.5	17.15	20.00	0.350	7.550	0.705	17.263	1.369	5.35	49.3	26
B20	7	56.0	16.51	19.88	0.375	8.000	0.585	17.515	1.183	6.84	46.7	30
CB201N	11	55.0	16.19	20.00	0.370	8.000	0.565	17.745	1.128	7.08	48.0	28
B20	10	55.0	16.16	20.00	0.370	8.000	0.565	17.675	1.163	7.08	47.8	28
18WF, CB183	20	124.0	36.45	18.64	0.651	11.889	1.071	15.173	1.734	5.55	23.3	-
18WF, B18b	13	124.0	36.45	18.64	0.651	11.889	1.071	15.370	1.635	5.55	23.6	-
18WF, B18b	14	114.0	33.51	18.48	0.595	11.833	0.991	15.370	1.555	5.97	25.8	-
18WF, CB183	21	114.0	33.51	18.48	0.595	11.833	0.991	15.173	1.654	5.97	25.5	-
18WF, CB183	21	105.0	30.86	18.32	0.554	11.792	0.911	15.173	1.574	6.47	27.4	-
18WF, B18b	14	105.0	30.86	18.32	0.554	11.792	0.911	15.370	1.475	6.47	27.7	-
CB183	18	100.0	29.40	18.24	0.498	12.069	0.864	14.985	1.627	6.98	30.1	-
G18	6	100.0	29.25	18.12	0.520	11.540	0.900	14.734	1.693	6.41	28.3	-
CB183N	19	99.0	29.12	18.27	0.485	11.795	0.885	15.179	1.548	6.66	31.3	-
G18	11	99.0	29.11	18.25	0.485	11.795	0.885	14.882	1.684	6.67	30.7	-
18WF, B18b	14	96.0	28.22	18.16	0.512	11.750	0.831	15.370	1.395	7.07	30.0	-
18WF, CB183	21	96.0	28.22	18.16	0.512	11.750	0.831	15.173	1.494	7.07	29.6	-
CB183	18	93.0	27.35	18.12	0.463	12.034	0.805	14.985	1.568	7.47	32.4	61
G18	6	93.0	27.14	18.00	0.480	11.500	0.840	14.734	1.633	6.85	30.7	-
G18	11	92.0	27.13	18.12	0.460	11.770	0.820	14.882	1.619	7.18	32.4	62
G18	2	92.0	27.12	18.00	0.480	11.500	0.839	14.698	1.651	6.86	30.6	-
G18	1	92.0	27.09	18.00	0.470	11.500	0.845	14.527	1.736	6.81	30.9	-
CB183N	19	92.0	27.06	18.14	0.460	11.770	0.817	15.179	1.480	7.20	33.0	59
G18	6	87.5	25.40	17.88	0.460	11.480	0.780	14.734	1.573	7.36	32.0	63
G18	11	86.0	25.35	18.00	0.440	11.750	0.760	14.882	1.559	7.74	33.8	56
CB183	18	86.0	25.29	18.00	0.429	12.000	0.745	14.985	1.508	8.05	34.9	53
CB183N	19	86.0	25.29	18.02	0.440	11.750	0.757	15.179	1.420	7.76	34.5	54
18WF, CB182	21	85.0	24.97	18.32	0.526	8.838	0.911	15.173	1.574	4.85	28.8	-
18WF, B18a	14	85.0	24.97	18.32	0.526	8.838	0.911	15.537	1.392	4.85	29.5	-
G18	8	81.0	23.81	17.75	0.440	11.460	0.715	14.734	1.508	8.02	33.5	57
CB183N	19	80.0	25.32	17.90	0.420	11.730	0.697	15.179	1.360	8.41	36.1	49
G18	11	80.0	23.59	17.88	0.420	11.730	0.700	14.882	1.499	8.38	35.4	51
CB182	18	78.0	22.94	18.24	0.471	8.565	0.866	14.985	1.629	4.95	31.8	64
B18a	12	77.0	22.70	18.16	0.480	8.790	0.831	15.191	1.485	5.29	31.6	64
18WF, CB182	21	77.0	22.63	18.16	0.475	8.787	0.831	15.173	1.494	5.29	31.9	63
18WF, B18a	14	77.0	22.63	18.16	0.475	8.787	0.831	15.537	1.312	5.29	32.7	60
CB182	19	77.0	22.65	18.15	0.480	8.790	0.824	15.179	1.487	5.33	31.6	64
B18a	10	74.0	21.79	18.12	0.440	8.770	0.819	15.175	1.473	5.36	34.5	54
B18a	4	74.0	21.61	18.12	0.440	8.770	0.819	15.175	1.473	5.36	34.5	54
CB182	18	72.0	21.17	18.11	0.436	8.530	0.800	14.985	1.563	5.33	34.4	55
CB182N	19	70.0	20.59	18.00	0.440	8.750	0.748	15.179	1.411	5.85	34.5	54
B18a	12	70.0	20.58	18.00	0.440	8.750	0.751	15.191	1.405	5.83	34.5	54
18WF, B18a	14	70.0	20.56	18.00	0.438	8.750	0.751	15.537	1.232	5.83	35.5	51
18WF, CB182	27	70.0	20.56	18.00	0.438	8.750	0.751	15.173	1.414	5.83	34.6	54
B18a	10	69.0	20.37	18.00	0.420	8.750	0.759	15.175	1.413	5.77	36.1	49
B18a	4	69.0	20.20	18.00	0.420	8.750	0.759	15.175	1.413	5.77	36.1	49
CB182	18	67.0	19.69	18.00	0.406	8.500	0.745	14.985	1.508	5.70	36.9	47
B18a	10	64.5	18.97	17.88	0.400	8.730	0.699	15.175	1.353	6.25	37.9	45
B18a	4	64.5	18.79	17.88	0.400	8.730	0.699	15.175	1.353	6.25	37.9	45
CB182N	19	64.0	18.83	17.87	0.405	8.715	0.683	15.179	1.346	6.38	37.5	46
B18a	12	64.0	18.81	17.87	0.405	8.715	0.686	15.191	1.340	6.35	37.5	46
18WF, B18a	14	64.0	18.80	17.87	0.403	8.715	0.686	15.537	1.167	6.35	38.6	43
18WF, CB182	21	64.0	18.80	17.87	0.403	8.715	0.686	15.173	1.349	6.35	37.7	45
18WF, CB181	22	60.0	17.64	18.25	0.416	7.558	0.695	15.875	1.188	5.44	38.2	44
18WF, B18	23	60.0	17.64	18.25	0.416	7.558	0.695	16.066	1.092	5.44	38.6	43
B18a	9	59.0	17.48	17.75	0.380	8.710	0.634	15.175	1.288	6.87	39.9	40
B18	3	59.0	17.40	18.00	0.495	7.675	0.592	15.700	1.150	6.49	31.7	64
B18	1	58.5	17.29	18.00	0.480	7.470	0.619	15.515	1.242	6.04	32.3	62
CB181	18	58.0	17.05	18.25	0.393	7.573	0.676	15.775	1.239	5.60	40.1	40

Table 2.3.1 Dimensions and Primary Properties – Steel Sections 1887-1952

Designation	X ₁ ksi	X ₂ x 106 (1/ksi) ²	Elastic Properties						Plastic Modulus	
			Axis x-x			Axis y-y			Z _x in.3	Z _y in.3
			I _x in.4	S _x in.3	r _x in.	I _y in.4	S _y in.3	r _y in.		
			ksi	(1/ksi) ²	in.4	in.3	in.	in.4	in.3	in.
B20a	2577	3643	1467.9	146.8	8.28	67.6	16.2	1.78	166.0	26.5
B20a	2430	4608	1466.5	146.7	8.28	75.9	17.3	1.88	165.7	28.1
B20	2372	6179	1268.9	126.9	7.91	51.2	12.6	1.59	147.3	21.0
B20a	2228	6553	1366.0	137.4	8.24	71.0	16.0	1.88	153.2	26.0
B20	2474	5025	1269.6	127.0	7.98	45.7	11.9	1.51	146.8	20.0
CB20	2077	9195	1309.9	129.4	8.28	60.0	14.9	1.77	145.6	23.2
B20	2176	7651	1305.6	128.9	8.27	53.5	13.3	1.67	145.5	21.6
B20	2210	7659	1222.1	122.2	8.05	49.8	12.3	1.62	140.3	20.4
B20	2204	7093	1283.2	127.6	8.26	54.3	13.5	1.70	144.7	21.9
B20	2210	7659	1222.1	122.2	8.05	49.8	12.3	1.62	140.3	20.4
B20	2330	5952	1223.0	122.3	8.12	44.3	11.6	1.54	139.8	19.3
B20	2132	8161	1227.9	122.4	8.23	51.5	12.9	1.69	138.9	20.8
CB201N	1922	12721	1189.1	118.2	8.21	53.9	13.4	1.75	132.9	20.9
B20	2250	6513	1193.1	119.3	8.22	43.4	11.5	1.57	135.4	19.0
B20	2023	10412	1185.5	117.8	8.20	47.5	11.8	1.64	132.9	19.3
B20	2064	9271	1172.2	117.2	8.22	48.3	12.1	1.66	132.8	19.7
B20	2048	9561	1169.7	117.0	8.22	48.6	12.2	1.68	132.6	19.7
B20	2064	9271	1172.2	117.2	8.22	48.3	12.1	1.66	132.8	19.7
B20	2209	6811	1176.3	117.6	8.28	43.0	11.4	1.58	132.8	18.7
B20	1927	12609	1086.1	109.3	8.11	43.5	10.9	1.62	123.0	17.8
CB201N	1769	17896	1075.6	107.6	8.15	48.3	12.1	1.73	120.8	18.7
B20	1870	14387	1071.9	107.2	8.14	41.8	10.5	1.61	120.7	17.2
18WF, CB183	3457	1030	2227.1	239.0	7.82	281.9	47.4	2.78	268.0	77.4
18WF, B18b	3539	937	2227.1	239.0	7.82	281.9	47.4	2.78	268.0	77.4
18WF, B18b	3281	1253	2033.8	220.1	7.79	255.6	43.2	2.76	245.6	70.8
18WF, CB183	3196	1391	2033.8	220.1	7.79	255.6	43.2	2.76	245.6	70.8
18WF, CB183	2956	1893	1852.5	202.2	7.75	231.0	39.2	2.73	224.7	64.6
18WF, B18b	3045	1681	1852.5	202.2	7.75	231.0	39.2	2.73	224.7	64.6
CB183	2785	2322	1783.4	195.6	7.79	253.4	42.0	2.94	215.1	63.9
G18	3124	1504	1725.7	190.5	7.68	202.6	35.1	2.63	213.2	56.4
CB183N	2798	2263	1771.1	194.5	7.81	242.2	41.1	2.88	214.5	62.5
G18	2996	1731	1767.7	193.7	7.79	211.2	35.8	2.69	213.9	57.5
18WF, B18b	2809	2314	1674.7	184.4	7.70	206.8	35.2	2.71	204.0	58.4
18WF, CB183	2715	2652	1674.7	184.4	7.70	206.8	35.2	2.71	204.0	58.4
CB183	2603	3023	1648.4	181.9	7.76	234.0	38.9	2.93	199.3	59.2
G18	2930	1925	1593.4	177.0	7.66	185.1	32.2	2.61	197.4	51.8
G18	2813	2230	1628.5	179.8	7.75	192.2	32.7	2.66	197.9	52.6
G18	2947	1881	1591.4	176.8	7.66	182.6	31.8	2.59	197.2	51.4
G18	3050	1625	1595.3	177.3	7.67	172.4	30.0	2.52	197.4	49.8
CB183N	2607	3011	1631.8	179.9	7.76	222.2	37.8	2.87	197.9	57.5
G18	2765	2436	1472.8	164.7	7.61	168.9	29.4	2.58	183.5	47.6
G18	2650	2842	1503.6	167.1	7.70	174.9	29.8	2.63	183.5	48.2
CB183	2419	4028	1514.1	168.2	7.74	214.7	35.8	2.91	183.5	54.4
CB183N	2441	3934	1506.6	167.2	7.72	204.8	34.9	2.85	183.5	53.1
18WF, CB182	3023	1901	1429.9	156.1	7.57	99.4	22.5	2.00	176.0	36.7
18WF, B18a	3048	1841	1429.9	156.1	7.57	99.4	22.5	2.00	176.0	36.7
G18	2576	3257	1360.6	153.3	7.56	151.7	26.5	2.52	168.6	43.1
CB183N	2360	5243	1383.4	154.6	7.67	187.6	32.0	2.82	169.2	48.7
G18	2490	3671	1380.7	154.4	7.65	157.8	26.9	2.59	169.3	43.8
CB182	2868	2301	1318.8	144.6	7.58	90.9	21.2	1.99	161.0	32.7
B18a	2877	2303	1287.1	141.7	7.53	85.0	19.3	1.93	159.2	31.1
18WF, CB182	2761	2699	1286.8	141.7	7.54	88.6	20.2	1.98	158.9	33.0
18WF, B18a	2788	2597	1286.8	141.7	7.54	88.6	20.2	1.98	158.9	33.0
CB182	2747	2767	1283.9	141.5	7.53	93.5	21.3	2.03	158.2	32.8
B18a	2783	2551	1249.2	137.9	7.57	82.9	18.9	1.95	154.0	30.3
B18a	2798	2504	1238.0	136.6	7.57	82.9	18.9	1.96	154.0	30.3
CB182	2664	3070	1208.1	133.4	7.55	82.9	19.4	1.98	147.8	29.9
CB182N	2512	3939	1155.3	128.4	7.49	83.7	19.1	2.02	142.9	29.4
B18a	2631	3282	1152.7	128.1	7.48	74.8	17.1	1.91	143.2	27.6
18WF, B18a	2553	3691	1153.9	128.2	7.49	78.5	17.9	1.95	143.2	29.5
18WF, CB182	2522	3872	1153.9	128.2	7.49	78.5	17.9	1.95	143.2	29.5
B18a	2615	3287	1153.7	128.2	7.53	75.6	17.3	1.93	142.9	27.8
B18a	2631	3221	1142.5	126.9	7.52	75.6	17.3	1.93	142.9	27.8
CB182	2492	3981	1117.1	124.1	7.53	76.4	18.0	1.97	136.9	27.6
B18a	2450	4302	1059.7	118.5	7.47	68.4	15.7	1.90	131.9	25.3
B18a	2463	4216	1048.5	117.3	7.47	68.4	15.7	1.91	131.9	25.3
CB182N	2310	5485	1047.2	117.2	7.46	75.5	17.3	2.00	129.9	26.6
B18a	2428	4502	1044.6	116.9	7.45	66.7	15.3	1.88	130.2	24.7
18WF, B18a	2354	5085	1045.8	117.0	7.46	70.3	16.1	1.93	130.2	26.7
18WF, CB182	2321	5385	1045.8	117.0	7.46	70.3	16.1	1.93	130.2	26.7
18WF, CB181	2309	5941	984.0	107.8	7.47	47.1	12.5	1.63	121.8	20.6
18WF, B18	2351	5530	984.0	107.8	7.47	47.1	12.5	1.63	121.8	20.6
B18a	2273	5864	960.3	108.2	7.41	60.7	13.9	1.86	120.2	22.6
B18	2448	5436	883.3	98.1	7.12	39.1	10.2	1.50	114.0	17.1
B18	2533	4662	883.6	98.2	7.15	35.9	9.6	1.44	113.9	16.4
CB181	2237	6622	960.8	105.3	7.51	49.0	13.0	1.70	118.0	20.0

Table 2.3.1 Dimensions and Primary Properties -- Steel Sections 1887-1952

Designation	Source Reference Number	Wt. per ft lb	Area	Depth	Web Thickness	Flange Width	Average Flange Thickness	Distance	Distance	Compact Section Criteria		
			A in.2	d in.	t _w in.	b _f in.	t _f in.	T in.	k in.	b/2t _f	h/t _w	F _y ^m ksi
B18	12	57.0	16.81	18.25	0.380	7.560	0.680	15.796	1.227	5.56	41.6	37
CB181N	19	57.0	16.76	18.25	0.378	7.558	0.675	15.775	1.238	5.60	41.7	37
18WF, B18	14	55.0	16.19	18.12	0.390	7.532	0.630	16.066	1.027	5.98	41.2	38
18WF, CB181	21	55.0	16.19	18.12	0.390	7.532	0.630	15.875	1.123	5.98	40.7	39
B18	10	54.5	16.06	18.12	0.370	7.540	0.645	15.738	1.191	5.85	42.5	36
B18	7	54.5	15.95	18.12	0.370	7.540	0.645	15.738	1.191	5.85	42.5	36
B18	5	54.5	15.87	18.00	0.410	7.590	0.592	15.700	1.150	6.42	38.3	44
B18	2	54.0	15.87	18.00	0.410	7.590	0.592	15.700	1.150	6.42	38.3	44
B18	1	52.5	15.40	18.00	0.375	7.370	0.619	15.515	1.242	5.96	41.4	38
B18	10	52.0	15.34	18.06	0.355	7.525	0.615	15.738	1.161	6.12	44.3	33
CB181N	18	52.0	15.30	18.11	0.354	7.534	0.607	15.775	1.170	6.21	44.6	32
CB181N	19	52.0	15.29	18.12	0.351	7.531	0.610	15.775	1.173	6.17	44.9	32
B18	12	52.0	15.29	18.12	0.350	7.530	0.615	15.796	1.162	6.12	45.1	32
B18	3	52.0	15.24	18.00	0.375	7.555	0.592	15.700	1.150	6.39	41.9	37
B18	7	52.0	15.22	18.06	0.355	7.525	0.615	15.738	1.161	6.12	44.3	33
CB181	18	51.0	15.00	18.02	0.375	7.555	0.562	15.775	1.125	6.72	42.1	36
18WF, CB181	21	50.0	14.71	18.00	0.358	7.500	0.570	15.875	1.063	6.58	44.3	33
18WF, B18	14	50.0	14.71	18.00	0.358	7.500	0.570	16.066	0.967	6.58	44.9	32
B18	12	49.0	14.47	18.06	0.330	7.510	0.585	15.796	1.132	6.42	47.9	28
B18	10	49.0	14.44	18.00	0.330	7.500	0.585	15.738	1.131	6.42	47.7	28
CB181N	19	49.0	14.40	18.06	0.327	7.507	0.580	15.775	1.143	6.47	48.2	28
B18	7	49.0	14.32	18.00	0.330	7.500	0.585	15.738	1.131	6.42	47.7	28
B18	5	49.0	14.25	18.00	0.320	7.500	0.592	15.700	1.150	6.34	49.1	27
B18	2	48.5	14.25	18.00	0.320	7.500	0.592	15.700	1.150	6.34	49.1	27
B18	1	48.5	14.23	18.00	0.310	7.300	0.619	15.515	1.242	5.90	50.0	26
B64	17	48.2	14.09	18.00	0.380	7.500	0.502	15.979	1.011	7.47	42.0	36
B64	16	48.0	14.08	18.00	0.380	7.500	0.502	15.979	1.011	7.47	42.0	36
B18	9	47.0	13.90	17.94	0.325	7.495	0.555	15.738	1.101	6.76	48.4	27
B18	12	47.0	13.84	18.00	0.320	7.500	0.555	15.796	1.102	6.76	49.4	26
CB181N	19	47.0	13.82	18.00	0.320	7.500	0.550	15.775	1.113	6.82	49.3	26
CB181	18	47.0	13.82	18.00	0.320	7.500	0.550	15.775	1.113	6.82	49.3	26
18WF, CB181	20	47.0	13.81	17.90	0.350	7.492	0.520	15.875	1.013	7.20	45.4	31
18WF, B18	13	47.0	13.81	17.90	0.350	7.492	0.520	16.066	0.917	7.20	45.9	31
B34	15	46.0	13.53	18.00	0.322	6.000	0.664	15.239	1.381	4.52	47.3	29
B23	24	46.0	13.34	18.00	0.380	6.000	0.555	15.780	1.110	5.41	41.5	37
---		45.0	13.24	17.86	0.335	7.477	0.499	15.877	0.992	7.49	47.4	29
CB165	7	115.0	33.82	16.24	0.532	14.068	0.918	12.875	1.681	7.66	24.2	-
16WF, CB163	9	114.0	33.51	16.64	0.631	11.629	1.035	13.245	1.698	5.62	21.0	-
16WF, B16b	5	114.0	33.51	16.64	0.631	11.629	1.035	13.442	1.599	5.62	21.3	-
CB165	7	107.0	31.46	16.11	0.496	14.032	0.855	12.875	1.618	8.21	26.0	-
16WF, CB163	9	105.0	30.87	16.48	0.584	11.582	0.955	13.245	1.618	6.06	22.7	-
16WF, B16b	5	105.0	30.87	16.48	0.584	11.582	0.955	13.442	1.519	6.06	23.0	-
CB165	7	100.0	29.41	16.00	0.464	14.000	0.800	12.875	1.563	8.75	27.7	-
16WF, CB163	10	96.0	28.22	16.32	0.535	11.533	0.875	13.245	1.538	6.59	24.8	-
16WF, B16b	6	96.0	28.22	16.32	0.535	11.533	0.875	13.442	1.439	6.59	25.1	-
G16	2	94.0	27.75	16.25	0.485	11.565	0.885	12.890	1.680	6.53	26.6	-
G16	4	90.0	26.51	16.25	0.490	11.580	0.825	13.010	1.620	7.02	26.6	-
CB164N	8	90.0	26.47	16.25	0.480	12.070	0.795	13.335	1.458	7.59	27.8	-
CB164	7	90.0	26.46	16.24	0.495	12.076	0.783	13.249	1.496	7.71	26.8	-
16WF, CB163	10	88.0	25.87	16.16	0.504	11.502	0.795	13.245	1.458	7.23	26.3	-
16WF, B16b	6	88.0	25.87	16.16	0.504	11.502	0.795	13.442	1.359	7.23	26.7	-
G16	2	87.0	25.68	16.12	0.450	11.530	0.820	12.890	1.615	7.03	28.6	-
CB164N	8	83.0	24.42	16.12	0.450	12.040	0.730	13.335	1.393	8.25	29.6	-
CB164	7	83.0	24.41	16.12	0.458	12.039	0.723	13.249	1.436	8.33	28.9	-
G16	4	83.0	24.36	16.12	0.450	11.540	0.760	13.010	1.555	7.59	28.9	-
G16	2	81.0	23.82	16.00	0.420	11.500	0.760	12.890	1.555	7.57	30.7	-
16WF, B16a	6	78.0	22.92	16.32	0.529	8.586	0.875	13.609	1.356	4.91	25.7	-
16WF, CB162	10	78.0	22.92	16.32	0.529	8.586	0.875	13.245	1.538	4.91	25.0	-
CB164	7	76.0	22.34	16.00	0.419	12.000	0.663	13.249	1.376	9.05	31.6	64
G16	4	76.0	22.34	16.00	0.410	11.500	0.700	13.010	1.495	8.21	31.7	64
CB164N	8	76.0	22.33	16.00	0.410	12.000	0.670	13.335	1.333	8.96	32.5	61
G16	2	74.5	21.96	15.88	0.390	11.470	0.700	12.890	1.495	8.19	33.1	59
B16a	2	71.5	21.07	16.25	0.455	8.565	0.833	13.287	1.482	5.14	29.2	-
16WF, B16a	6	71.0	20.86	16.16	0.486	8.543	0.795	13.609	1.276	5.37	28.0	-
16WF, CB162	10	71.0	20.86	16.16	0.486	8.543	0.795	13.245	1.458	5.37	27.3	-
CB163	7	68.0	20.00	16.23	0.438	8.563	0.776	13.249	1.489	5.52	30.2	-
B16a	4	68.0	19.99	16.25	0.435	8.550	0.785	13.381	1.435	5.45	30.8	-
CB163N	8	68.0	19.99	16.23	0.436	8.510	0.785	13.335	1.448	5.42	30.6	-
B16a	2	66.0	19.40	16.12	0.420	8.530	0.768	13.287	1.417	5.56	31.6	64
16WF, B16a	6	64.0	18.80	16.00	0.443	8.500	0.715	13.609	1.196	5.94	30.7	-
16WF, CB162	10	64.0	18.80	16.00	0.443	8.500	0.715	13.245	1.378	5.94	29.9	-
B16a	4	63.0	18.55	16.12	0.415	8.530	0.720	13.381	1.370	5.92	32.2	62
CB163N	8	63.0	18.52	16.12	0.403	8.477	0.730	13.335	1.393	5.81	33.1	59
CB163	7	63.0	18.52	16.11	0.406	8.531	0.720	13.249	1.433	5.92	32.6	60
B16a	2	60.5	17.89	16.00	0.390	8.500	0.708	13.287	1.357	6.01	34.1	55

Table 2.3.1 Dimensions and Primary Properties – Steel Sections 1887-1952

Designation	X ₁ ksi	X ₂ x 106 (1/ksi) ²	Elastic Properties						Plastic Modulus	
			Axis x-x			Axis y-y			Z _x in.3	Z _y in.3
			I _x	S _x	r _x	I _y	S _y	r _y		
			in.4	in.3	in.	in.4	in.3	in.		
B18	2313	5712	953.2	104.5	7.53	44.0	11.6	1.62	117.4	18.8
CB181N	2208	6869	952.0	104.3	7.54	48.7	12.9	1.70	116.7	19.9
18WF, B18	2170	7677	889.9	98.2	7.41	42.0	11.1	1.61	110.7	18.5
18WF, CB181	2125	8350	889.9	98.2	7.41	42.0	11.1	1.61	110.7	18.5
B18	2228	6695	896.1	98.9	7.47	41.1	10.9	1.60	111.1	17.6
B18	2238	6587	888.5	98.1	7.46	41.1	10.9	1.60	111.1	17.6
B18	2229	7231	842.0	93.6	7.28	37.7	9.9	1.54	107.1	16.4
B18	2229	7231	842.0	93.6	7.28	37.7	9.9	1.54	107.1	16.4
B18	2288	6254	832.9	92.5	7.35	34.4	9.3	1.49	105.5	15.6
B18	2137	7909	851.7	94.3	7.45	38.7	10.3	1.59	105.8	16.6
CB181N	2021	9892	855.1	94.4	7.48	43.3	11.5	1.68	105.3	17.8
CB181N	2022	9822	857.3	94.6	7.49	43.5	11.6	1.69	105.5	17.8
B18	2122	8092	857.1	94.6	7.49	38.8	10.3	1.59	106.0	16.7
B18	2152	7987	825.0	91.7	7.36	37.1	9.8	1.56	104.2	16.1
B18	2147	7775	844.1	93.5	7.45	38.7	10.3	1.59	105.8	16.6
CB181	1973	11482	810.0	89.9	7.35	40.5	10.7	1.64	100.9	16.6
18WF, CB181	1938	12050	800.6	89.0	7.38	37.2	9.9	1.59	100.0	16.6
18WF, B18	1986	10925	800.6	89.0	7.38	37.2	9.9	1.59	100.0	16.6
B18	2022	9742	810.3	89.7	7.48	36.3	9.7	1.58	100.3	15.7
B18	2027	9642	802.8	89.2	7.46	36.1	9.6	1.58	99.7	15.6
CB181N	1914	12063	808.6	89.5	7.49	41.0	10.9	1.69	99.5	16.8
B18	2037	9470	795.3	88.4	7.45	36.1	9.6	1.59	99.7	15.6
B18	2048	9112	798.3	88.7	7.48	36.2	9.7	1.59	99.8	15.7
B18	2048	9112	798.3	88.7	7.48	36.2	9.7	1.59	99.8	15.7
B18	2167	7179	801.3	89.0	7.50	33.4	9.2	1.53	100.1	15.1
B64	1958	12623	737.1	81.9	7.23	30.0	8.0	1.46	93.3	13.4
B64	1957	12623	737.1	81.9	7.23	30.0	8.0	1.46	93.3	13.4
B18	1954	11299	764.1	85.2	7.42	34.0	9.1	1.56	95.2	14.7
B18	1940	11558	768.8	85.4	7.45	34.1	9.1	1.57	95.4	14.8
CB181N	1837	14344	768.6	85.4	7.46	38.7	10.3	1.67	94.8	15.9
CB181	1837	14344	768.6	85.4	7.46	38.7	10.3	1.67	94.8	15.9
18WF, CB181	1823	15766	736.4	82.3	7.30	33.5	9.0	1.56	92.6	15.1
18WF, B18	1875	14081	736.4	82.3	7.30	33.5	9.0	1.56	92.6	15.1
B34	2353	5531	733.2	81.5	7.36	19.9	6.6	1.21	91.3	11.1
B23	2143	9327	675.7	75.1	7.12	17.1	5.7	1.13	85.1	9.7
----	1751	18508	704.5	78.9	7.30	31.9	8.5	1.55	88.6	14.4
CB165	3298	1103	1665.6	205.2	7.02	426.2	60.6	3.55	225.4	91.9
16WF, CB163	3755	723	1642.6	197.4	7.00	254.6	43.8	2.76	221.3	71.4
16WF, B16b	3849	655	1642.6	197.4	7.00	254.6	43.8	2.76	221.3	71.4
CB165	3082	1436	1537.2	190.8	6.99	393.9	56.1	3.54	208.7	85.1
16WF, CB163	3477	975	1497.5	181.7	6.96	230.7	39.8	2.73	202.7	65.3
16WF, B16b	3575	873	1497.5	181.7	6.96	230.7	39.8	2.73	202.7	65.3
CB165	2892	1840	1426.8	178.3	6.97	366.0	52.3	3.53	194.3	79.2
16WF, CB163	3194	1355	1355.1	166.1	6.93	207.2	35.9	2.71	184.3	59.2
16WF, B16b	3296	1195	1355.1	166.1	6.93	207.2	35.9	2.71	184.3	59.2
G16	3382	1044	1341.4	165.1	6.95	199.9	34.6	2.68	182.5	55.3
G16	3210	1313	1274.1	156.8	6.93	185.1	32.0	2.64	173.3	51.5
CB164N	2870	2017	1285.5	158.2	6.97	233.2	38.6	2.97	174.1	58.8
CB164	2874	2034	1275.5	157.1	6.94	230.0	38.1	2.95	172.8	58.0
16WF, CB163	2941	1890	1222.6	151.3	6.87	185.2	32.2	2.67	167.2	53.5
16WF, B16b	3050	1633	1222.6	151.3	6.87	185.2	32.2	2.67	167.2	53.5
G16	3161	1358	1230.8	152.7	6.92	181.3	31.5	2.66	168.0	50.5
CB164N	2658	2740	1172.3	145.4	6.93	212.5	35.3	2.95	159.4	53.7
CB164	2664	2734	1167.7	144.9	6.92	210.4	35.0	2.94	158.7	53.2
G16	2983	1744	1161.6	144.1	6.90	166.4	28.8	2.61	158.5	46.6
G16	2961	1756	1131.3	141.4	6.89	164.6	28.6	2.63	155.0	46.2
16WF, B16a	3339	1264	1042.6	127.8	6.74	87.5	20.4	1.95	144.1	33.3
16WF, CB162	3311	1307	1042.6	127.8	6.74	87.5	20.4	1.95	144.1	33.3
CB164	2451	3781	1061.3	132.7	6.89	191.1	31.8	2.92	144.6	48.4
G16	2771	2318	1058.6	132.3	6.88	149.3	26.0	2.59	144.8	42.2
CB164N	2442	3802	1065.5	133.2	6.91	193.1	32.2	2.94	145.3	48.9
G16	2761	2309	1033.6	130.2	6.86	148.1	25.8	2.60	142.1	41.9
B16a	3181	1471	973.5	119.8	6.80	79.0	18.4	1.94	134.1	29.4
16WF, B16a	3067	1771	936.9	115.9	6.70	77.9	18.2	1.93	130.1	29.9
16WF, CB162	3035	1845	936.9	115.9	6.70	77.9	18.2	1.93	130.1	29.9
CB163	2887	2171	923.7	113.9	6.80	81.3	19.0	2.02	126.2	29.2
B16a	3007	1845	925.7	113.9	6.81	73.6	17.2	1.92	127.2	27.5
CB163N	2892	2151	924.4	113.9	6.80	80.8	19.0	2.01	126.6	29.1
B16a	2953	1966	888.4	110.2	6.77	71.2	16.7	1.92	122.8	26.7
16WF, B16a	2791	2568	833.8	104.2	6.66	68.4	16.1	1.91	116.4	26.5
16WF, CB162	2756	2702	833.8	104.2	6.66	68.4	16.1	1.91	116.4	26.5
B16a	2806	2447	845.9	105.0	6.75	66.3	15.5	1.89	116.9	25.0
CB163N	2693	2829	851.7	105.7	6.78	74.2	17.5	2.00	116.9	26.8
CB163	2690	2858	849.9	105.5	6.77	74.6	17.5	2.01	116.4	26.8
B16a	2747	2614	812.1	101.5	6.74	64.3	15.1	1.90	112.6	24.3

Table 2.3.1 Dimensions and Primary Properties -- Steel Sections 1887-1952

Designation	Source Reference Number	Wt. per ft lb	Area	Depth	Web Thickness	Flange Width	Average Flange Thickness	Distance	Distance	Compact Section Criteria		
			A	d	t _w	b _f	t _f	T	k	b _f /2t _f	h/t _w	F _y "
			in.2	in.	in.	in.	in.	in.	in.	in.		
CB163	7	58.0	17.06	16.00	0.375	8.500	0.663	13.249	1.376	6.41	35.3	52
CB163N	8	58.0	17.06	16.00	0.375	8.449	0.670	13.335	1.333	6.31	35.6	51
B16a	4	58.0	17.05	16.00	0.385	8.500	0.660	13.381	1.310	6.44	34.8	53
16WF, B16a	6	58.0	17.04	15.86	0.407	8.464	0.645	13.609	1.126	6.56	33.4	58
16WF, CB162	10	58.0	17.04	15.86	0.407	8.464	0.645	13.245	1.308	6.56	32.5	61
B16a	2	56.5	16.63	15.88	0.375	8.485	0.648	13.287	1.297	6.55	35.4	51
B16	3	50.0	14.78	16.25	0.365	7.320	0.628	13.910	1.170	5.83	38.1	44
B16	1	50.0	14.72	16.12	0.360	7.290	0.635	13.766	1.177	5.74	38.2	44
CB162N	8	50.0	14.70	16.25	0.360	7.318	0.628	14.069	1.091	5.83	39.1	42
CB162	7	50.0	14.70	16.25	0.362	7.072	0.647	13.935	1.160	5.47	38.5	43
16WF, CB161	10	50.0	14.70	16.25	0.380	7.073	0.628	14.009	1.121	5.63	36.9	47
16WF, B16	6	50.0	14.70	16.25	0.380	7.073	0.628	14.200	1.025	5.63	37.4	46
16WF	11	45.1	13.26	15.88	0.417	7.110	0.487	14.107	0.884	7.30	33.8	56
B16	3	45.0	13.26	16.12	0.330	7.285	0.563	13.910	1.105	6.47	42.2	36
16WF, B16	6	45.0	13.24	16.12	0.346	7.039	0.563	14.200	0.960	6.25	41.0	38
16WF, CB161	10	45.0	13.24	16.12	0.346	7.039	0.563	14.009	1.056	6.25	40.5	39
CB162N	8	45.0	13.23	16.12	0.328	7.286	0.563	14.069	1.026	6.47	42.9	35
CB162	7	45.0	13.23	16.13	0.326	7.036	0.584	13.935	1.097	6.02	42.7	35
B16	1	45.0	13.20	16.00	0.320	7.250	0.575	13.766	1.117	6.30	43.0	35
CB162	7	43.0	12.65	15.93	0.375	7.085	0.487	13.935	1.000	7.27	37.2	47
B16	3	40.0	11.83	16.00	0.295	7.250	0.503	13.910	1.045	7.21	47.2	29
CB162N	8	40.0	11.78	16.00	0.292	7.250	0.503	14.069	0.966	7.21	48.2	28
B16	1	40.0	11.78	15.88	0.285	7.215	0.515	13.766	1.057	7.00	48.3	28
16WF, B16	6	40.0	11.77	16.00	0.307	7.000	0.503	14.200	0.900	6.96	46.3	30
16WF, CB161	10	40.0	11.77	16.00	0.307	7.000	0.503	14.009	0.996	6.96	45.6	31
CB162	7	40.0	11.75	16.00	0.290	7.000	0.520	13.935	1.033	6.73	48.1	28
16WF	11	38.7	11.39	15.88	0.299	6.992	0.487	13.940	0.968	7.18	46.6	30
CB161	7	38.0	11.17	16.01	0.314	6.024	0.526	13.935	1.039	5.73	44.4	33
CB162N	8	37.0	10.88	15.88	0.290	7.248	0.443	14.069	0.906	8.18	48.5	27
B16	4	37.0	10.88	15.88	0.290	7.245	0.443	13.910	0.985	8.18	48.0	28
16WF, B16	6	36.0	10.59	15.85	0.299	6.992	0.428	14.200	0.825	8.17	47.5	29
16WF, CB161	10	36.0	10.59	15.85	0.299	6.992	0.428	14.009	0.921	8.17	46.9	29
B16	2	35.0	10.29	15.81	0.285	7.240	0.408	13.910	0.950	8.87	48.8	27
CB161	7	35.0	10.29	15.93	0.290	6.000	0.485	13.935	0.998	6.19	48.1	28
---		31.0	9.12	15.84	0.275	5.525	0.442	13.971	0.935	6.25	50.8	25
---		26.0	7.65	15.65	0.250	5.500	0.345	13.975	0.837	7.97	55.9	21
G15b	8	147.0	43.30	15.12	0.830	11.780	1.378	10.278	2.421	4.27	12.4	-
G15b	5	147.0	42.73	15.12	0.830	11.780	1.378	10.278	2.421	4.27	12.4	-
G15b	8	141.0	41.44	15.00	0.800	11.750	1.318	10.278	2.361	4.46	12.8	-
G15b	5	141.0	40.86	15.00	0.800	11.750	1.318	10.278	2.361	4.46	12.8	-
G15b	1	140.0	41.28	15.00	0.800	11.750	1.337	9.929	2.536	4.39	12.4	-
G15b	2	140.0	41.27	15.00	0.800	11.750	1.337	10.121	2.440	4.40	12.7	-
G15b	8	135.0	39.58	14.88	0.770	11.720	1.258	10.278	2.301	4.66	13.3	-
G15b	5	135.0	39.01	14.88	0.770	11.720	1.258	10.278	2.301	4.66	13.3	-
G15b	7	127.0	37.47	14.75	0.730	11.680	1.193	10.278	2.236	4.90	14.1	-
G15a	8	111.0	32.75	15.12	0.640	11.290	1.067	11.247	1.937	5.29	17.6	-
G15a	5	111.0	32.40	15.12	0.640	11.290	1.067	11.247	1.937	5.29	17.6	-
CB153N	13	108.0	31.77	15.32	0.617	11.097	1.055	11.985	1.668	5.26	19.4	-
G15	9	108.0	31.75	15.32	0.615	11.095	1.055	11.729	1.795	5.26	19.1	-
G15a	8	105.0	30.80	15.00	0.600	11.250	1.007	11.247	1.877	5.59	18.7	-
G15a	5	105.0	30.45	15.00	0.600	11.250	1.007	11.247	1.877	5.59	18.7	-
G15a	1	104.0	30.58	15.00	0.600	11.250	1.013	10.929	2.036	5.55	18.2	-
G15a	2	104.0	30.50	15.00	0.600	11.250	1.010	11.123	1.939	5.57	18.5	-
G15	9	99.0	29.14	15.16	0.560	11.040	0.975	11.729	1.715	5.66	20.9	-
CB153N	13	99.0	29.11	15.16	0.559	11.039	0.975	11.985	1.588	5.66	21.4	-
G15a	8	99.0	29.00	14.88	0.570	11.220	0.947	11.247	1.817	5.92	19.7	-
G15a	5	99.0	28.65	14.88	0.570	11.220	0.947	11.247	1.817	5.92	19.7	-
G15a	7	94.0	27.66	14.80	0.540	11.190	0.907	11.247	1.777	6.17	20.8	-
G15	9	91.0	26.77	15.00	0.520	11.000	0.895	11.729	1.635	6.15	22.6	-
CB153N	13	91.0	26.76	15.00	0.520	11.000	0.895	11.985	1.508	6.15	23.0	-
G15	9	85.0	25.01	14.88	0.490	10.970	0.835	11.729	1.575	6.57	23.9	-
CB153N	13	85.0	24.99	14.88	0.490	10.970	0.835	11.985	1.448	6.57	24.5	-
G15	8	80.5	23.66	15.12	0.480	10.790	0.785	12.075	1.522	6.87	25.2	-
G15	5	80.5	23.44	15.12	0.480	10.790	0.785	12.075	1.522	6.87	25.2	-
G15	8	74.0	21.76	15.00	0.440	10.750	0.725	12.075	1.462	7.41	27.4	-
G15	5	74.0	21.55	15.00	0.440	10.750	0.725	12.075	1.462	7.41	27.4	-
G15	1	73.0	21.52	15.00	0.420	10.500	0.755	11.832	1.584	6.95	28.2	-
G15	2	73.0	21.49	15.00	0.430	10.500	0.747	12.007	1.496	7.03	27.9	-
B15b	1	72.0	21.27	15.00	0.540	7.150	0.997	11.399	1.801	3.59	21.1	-
B15a	9	72.0	21.20	15.31	0.525	7.585	0.920	12.215	1.548	4.12	23.3	-
CB152N	13	72.0	21.18	15.31	0.522	7.580	0.920	12.245	1.533	4.12	23.5	-
B15b	4	71.5	20.95	15.00	0.520	7.500	0.942	11.674	1.663	3.98	22.4	-
B15b	8	71.5	21.04	15.00	0.520	7.500	0.931	11.720	1.640	4.03	22.5	-
B15b	6	71.5	20.79	15.00	0.520	7.500	0.931	11.720	1.640	4.03	22.5	-
B15b	2	71.0	20.95	15.00	0.520	7.500	0.942	11.674	1.663	3.98	22.4	-

Table 2.3.1 Dimensions and Primary Properties -- Steel Sections 1887-1952

Designation	X ₁ ksi	X ₂ x 106 (1/ksi) ²	Elastic Properties						Plastic Modulus	
			Axis x-x			Axis y-y			Z _x in.3	Z _y in.3
			I _x in.4	S _x in.3	r _x in.	I _y in.4	S _y in.3	r _y in.		
CB163	2492	3855	776.6	97.1	6.75	68.0	16.0	2.00	106.6	24.5
CB163N	2493	3847	776.5	97.1	6.75	67.4	16.0	1.99	106.9	24.4
B16a	2603	3296	769.7	96.2	6.72	59.4	14.0	1.87	106.7	22.5
16WF, B16a	2554	3653	746.4	94.1	6.62	60.5	14.3	1.88	104.7	23.7
16WF, CB162	2515	3887	746.4	94.1	6.62	60.5	14.3	1.88	104.7	23.7
B16a	2568	3456	742.3	93.5	6.68	57.8	13.6	1.86	103.6	22.0
B16	2430	4623	669.0	82.3	6.73	36.6	10.0	1.57	92.3	16.2
B16	2459	4361	658.7	81.7	6.69	36.6	10.0	1.58	91.5	16.2
CB162N	2290	5808	668.1	82.2	6.74	41.1	11.2	1.67	92.0	17.3
CB162	2370	5091	666.0	81.9	6.73	38.2	10.8	1.61	91.7	16.7
16WF, CB161	2351	5432	655.4	80.7	6.68	34.8	9.8	1.54	90.7	16.2
16WF, B16	2398	5019	655.4	80.7	6.68	34.8	9.8	1.54	90.7	16.2
16WF	2361	6155	530.1	66.8	6.32	24.2	6.8	1.35	76.4	13.0
B16	2202	6806	594.5	73.8	6.69	31.9	8.8	1.55	82.3	14.2
16WF, B16	2178	7362	583.3	72.4	6.64	30.5	8.7	1.52	81.1	14.4
16WF, CB161	2128	8089	583.3	72.4	6.64	30.5	8.7	1.52	81.1	14.4
CB162N	2069	8693	594.6	73.8	6.70	36.3	10.0	1.66	82.3	15.3
CB162	2145	7511	595.0	73.8	6.71	34.0	9.7	1.60	82.1	14.9
B16	2232	6315	588.6	73.6	6.68	32.2	8.9	1.56	81.9	14.3
CB162	2050	10253	523.8	65.7	6.44	28.9	8.2	1.51	74.3	12.7
B16	1991	10127	526.2	65.8	6.67	27.6	7.6	1.53	73.0	12.4
CB162N	1855	13345	525.9	65.7	6.88	32.0	8.8	1.65	72.9	13.5
B16	2019	9353	521.7	65.7	6.66	27.9	7.7	1.54	72.8	12.5
16WF, B16	1961	11109	515.5	64.4	6.62	26.5	7.6	1.50	71.8	12.7
16WF, CB161	1907	12430	515.5	64.4	6.62	26.5	7.6	1.50	71.8	12.7
CB162	1918	11623	524.6	65.6	6.68	29.8	8.5	1.59	72.6	13.1
16WF	2109	8293	490.8	61.9	6.56	22.9	6.5	1.42	69.0	12.2
CB161	2030	10262	475.1	59.3	6.52	19.2	6.4	1.31	66.6	9.9
CB162N	1710	19289	470.0	59.2	6.57	28.1	7.8	1.61	65.9	12.0
B16	1845	14271	469.2	59.1	6.57	23.7	6.6	1.48	65.8	10.8
16WF, B16	1785	16982	446.3	56.3	6.49	22.1	6.3	1.45	63.0	10.8
16WF, CB161	1722	19618	446.3	56.3	6.49	22.1	6.3	1.45	63.0	10.8
B16	1760	17641	435.8	55.1	6.51	21.4	5.9	1.44	61.5	9.8
CB161	1878	13889	435.5	54.7	6.50	17.5	5.8	1.30	61.2	9.0
----	1767	18742	372.5	47.0	6.39	11.6	4.2	1.13	53.0	7.0
----	1502	38032	298.1	38.1	6.24	8.7	3.2	1.07	43.0	5.5
G15b	6118	104	1685.4	222.9	6.24	347.5	59.0	2.83	254.6	93.2
G15b	6146	102	1666.2	220.4	6.24	347.3	59.0	2.85	254.6	93.2
G15b	5888	121	1596.8	212.9	6.21	328.5	55.9	2.82	242.3	88.4
G15b	5916	118	1577.7	210.4	6.21	328.3	55.9	2.83	242.3	88.4
G15b	6155	101	1591.5	212.2	6.21	319.2	54.3	2.78	244.6	87.4
G15b	6037	109	1592.7	212.4	6.21	331.0	56.3	2.83	244.7	89.3
G15b	5659	141	1509.9	202.9	6.18	309.7	52.9	2.80	230.1	83.7
G15b	5688	138	1490.7	200.4	6.18	309.5	52.8	2.82	230.1	83.7
G15b	5396	169	1415.6	191.9	6.15	289.1	49.5	2.78	216.6	78.5
G15a	4566	328	1319.3	174.5	6.35	231.3	41.0	2.66	196.1	65.1
G15a	4586	321	1306.3	172.8	6.35	231.2	41.0	2.67	196.1	65.1
CB153N	4142	481	1320.4	172.4	6.45	240.6	43.4	2.75	193.9	66.2
G15	4369	390	1317.5	172.0	6.44	217.0	39.1	2.61	193.6	62.2
G15a	4325	403	1231.3	164.2	6.32	214.4	38.1	2.64	183.6	60.7
G15a	4348	394	1218.2	162.4	6.32	214.3	38.1	2.65	183.6	60.7
G15a	4542	333	1219.7	162.6	6.32	203.3	36.1	2.58	184.3	59.0
G15a	4401	376	1220.1	162.7	6.32	213.0	37.9	2.64	184.0	60.5
G15	4051	520	1198.4	158.1	6.41	195.7	35.5	2.59	177.0	56.5
CB153N	3820	654	1200.4	158.4	6.42	218.8	39.6	2.74	177.1	60.4
G15a	4102	496	1147.7	154.3	6.29	198.5	35.4	2.62	171.9	56.5
G15a	4125	484	1134.7	152.5	6.29	198.4	35.4	2.63	171.9	56.5
G15a	3938	579	1090.2	147.3	6.28	187.4	33.5	2.60	163.6	53.5
G15	3757	698	1086.8	144.9	6.37	175.7	31.9	2.56	161.4	51.0
CB153N	3528	893	1089.1	145.2	6.38	198.7	36.1	2.73	161.5	55.0
G15	3536	886	1004.9	135.1	6.34	161.0	29.3	2.54	149.9	47.0
CB153N	3306	1152	1007.2	135.4	6.35	183.9	33.5	2.71	150.0	51.0
G15	3303	1184	977.4	129.3	6.43	143.1	26.5	2.46	143.3	42.7
G15	3318	1162	968.5	128.1	6.43	143.0	26.5	2.47	143.3	42.7
G15	3073	1565	892.7	119.0	6.40	128.9	24.0	2.43	131.3	38.7
G15	3089	1534	883.8	117.8	6.40	128.9	24.0	2.45	131.3	38.7
G15	3296	1167	886.5	118.2	6.42	116.6	22.2	2.33	131.7	36.9
G15	3163	1383	883.4	117.8	6.41	123.2	23.5	2.39	131.2	38.0
B15b	4372	439	797.9	106.4	6.13	55.1	15.4	1.61	122.5	24.9
B15a	3827	742	837.2	109.4	6.28	62.1	16.4	1.71	124.2	26.2
CB152N	3690	856	838.2	109.5	6.29	67.0	17.7	1.78	124.0	27.3
B15b	4052	584	796.2	106.2	6.16	61.3	16.3	1.71	121.6	26.1
B15b	3976	632	799.5	106.6	6.16	60.9	16.2	1.70	120.6	25.9
B15b	4001	616	789.4	105.3	6.16	60.8	16.2	1.71	120.6	25.9
B15b	4052	584	796.2	106.2	6.16	61.3	16.3	1.71	121.6	26.1

Table 2.3.1 Dimensions and Primary Properties -- Steel Sections 1887-1952

Designation	Source Reference Number	Wt. per ft lb	Area	Depth	Web Thickness	Flange Width	Average Flange Thickness	Distance	Distance	Compact Section Criteria		
			A	d	t _w	b _f	t _f	T	k	b _f /2t _f	h/t _w	F _y "
			in.2	in.	in.	in.	in.	in.	in.	in.		
G15	8	69.0	20.18	14.88	0.420	10.730	0.665	12.075	1.402	8.07	28.8	-
G15	5	69.0	19.96	14.88	0.420	10.730	0.665	12.075	1.402	8.07	28.8	-
CB152N	13	66.0	19.41	15.16	0.480	7.538	0.845	12.245	1.458	4.46	25.5	-
B15a	9	66.0	19.38	15.16	0.480	7.540	0.845	12.215	1.473	4.46	25.4	-
G15	7	64.5	19.09	14.82	0.390	10.700	0.635	12.075	1.372	8.43	31.0	-
B15a	1	64.0	18.85	15.00	0.600	7.200	0.747	12.133	1.434	4.82	20.2	-
B15a	3	64.0	18.81	15.00	0.605	7.195	0.739	12.265	1.368	4.87	20.3	-
CB152N	13	60.0	17.63	15.00	0.442	7.500	0.765	12.245	1.378	4.90	27.7	-
B15a	9	60.0	17.58	15.00	0.440	7.500	0.765	12.215	1.393	4.90	27.8	-
B15a	8	59.5	17.49	15.12	0.450	7.040	0.798	12.289	1.416	4.41	27.3	-
B15a	6	59.5	17.32	15.12	0.450	7.040	0.798	12.289	1.416	4.41	27.3	-
CB152N	13	55.0	16.18	14.88	0.405	7.463	0.705	12.245	1.318	5.29	30.2	-
B15a	9	55.0	16.16	14.88	0.405	7.465	0.705	12.215	1.333	5.29	30.2	-
B15a	8	54.5	16.05	15.00	0.410	7.000	0.738	12.289	1.356	4.75	30.0	-
B15a	4	54.5	15.88	15.00	0.410	7.000	0.739	12.265	1.368	4.74	29.9	-
B15a	6	54.5	15.87	15.00	0.410	7.000	0.738	12.289	1.356	4.75	30.0	-
B15a	2	54.0	15.88	15.00	0.410	7.000	0.739	12.265	1.368	4.74	29.9	-
B15a	1	54.0	15.85	15.00	0.400	7.000	0.747	12.133	1.434	4.69	30.3	-
B15a	8	50.5	14.84	14.88	0.385	6.975	0.678	12.289	1.296	5.15	31.9	63
B15a	6	50.5	14.66	14.88	0.385	6.975	0.678	12.289	1.296	5.15	31.9	63
B15	9	49.0	14.43	15.25	0.385	6.835	0.655	12.878	1.186	5.22	33.4	58
CB152N	13	49.0	14.41	15.25	0.382	6.832	0.655	12.915	1.168	5.22	33.8	56
B15a	7	46.0	13.63	14.75	0.365	6.955	0.613	12.289	1.231	5.68	33.7	57
B15	3	46.0	13.52	15.00	0.440	6.810	0.543	12.667	1.167	6.27	28.8	-
B15	1	46.0	13.46	15.00	0.430	6.810	0.550	12.742	1.129	6.20	29.6	-
B15	9	44.0	12.94	15.12	0.345	6.795	0.590	12.878	1.121	5.76	37.3	46
CB151N	13	44.0	12.93	15.12	0.343	6.793	0.590	12.915	1.103	5.76	37.7	45
B15	8	42.5	12.50	15.09	0.325	6.785	0.580	12.868	1.111	5.85	39.6	41
B15	6	42.5	12.39	15.09	0.325	6.785	0.580	12.868	1.111	5.85	39.6	41
B15	1	42.0	12.41	15.00	0.360	6.740	0.550	12.742	1.129	6.13	35.4	51
B15	3	41.0	12.02	15.00	0.340	6.710	0.543	12.667	1.167	6.18	37.3	46
B15	8	40.0	11.80	15.03	0.305	6.765	0.550	12.868	1.081	6.16	42.2	36
B15	6	40.0	11.68	15.03	0.305	6.765	0.550	12.868	1.081	6.16	42.2	36
CB151N	13	39.0	11.47	15.00	0.300	6.750	0.530	12.915	1.043	6.37	43.1	35
B15	9	39.0	11.45	15.00	0.300	6.750	0.530	12.878	1.061	6.37	42.9	35
B15	8	38.5	11.37	15.00	0.290	6.750	0.535	12.868	1.066	6.31	44.4	33
B15	4	38.5	11.27	15.00	0.290	6.660	0.543	12.834	1.083	6.13	44.3	33
B15	6	38.5	11.26	15.00	0.290	6.750	0.535	12.868	1.066	6.31	44.4	33
B15	2	38.0	11.27	15.00	0.290	6.660	0.543	12.834	1.083	6.13	44.3	33
B15	1	38.0	11.21	15.00	0.280	6.660	0.550	12.742	1.129	6.06	45.5	31
B65	11	37.5	10.91	15.00	0.332	6.750	0.456	13.169	0.915	7.40	39.7	41
B65	12	37.3	10.91	15.00	0.332	6.750	0.456	13.169	0.915	7.40	39.7	41
B35	10	36.0	10.63	15.00	0.289	5.500	0.588	12.513	1.244	4.68	43.3	34
B15	7	36.0	10.61	14.91	0.280	6.740	0.490	12.868	1.021	6.88	46.0	30
B15	9	35.0	10.34	14.88	0.280	6.730	0.470	12.878	1.001	7.16	46.0	30
CB151N	13	35.0	10.29	14.88	0.275	6.725	0.470	12.915	0.983	7.15	47.0	29
B24	14	35.0	10.22	15.00	0.330	5.500	0.490	13.023	0.988	5.61	39.5	41
14WF, CB145	11	136.0	39.98	14.75	0.660	14.740	1.063	11.299	1.726	6.93	17.1	-
14WF, B14d	6	136.0	39.98	14.75	0.660	14.740	1.063	11.299	1.726	6.93	17.1	-
CB145N	9	136.0	39.98	14.75	0.662	14.740	1.063	11.199	1.776	6.93	16.9	-
CB146	7	135.0	39.70	14.45	0.645	15.239	1.031	10.965	1.744	7.39	17.0	-
CB145N	9	127.0	37.33	14.62	0.612	14.690	0.998	11.199	1.711	7.36	18.3	-
14WF, CB145	11	127.0	37.33	14.62	0.610	14.690	0.998	11.299	1.661	7.36	18.5	-
14WF, B14d	6	127.0	37.33	14.62	0.610	14.690	0.998	11.299	1.661	7.36	18.5	-
CB146	7	125.0	36.75	14.30	0.597	15.191	0.957	10.965	1.670	7.94	18.4	-
14WF, CB145	11	119.0	34.99	14.50	0.570	14.650	0.938	11.299	1.601	7.81	19.8	-
14WF, B14d	6	119.0	34.99	14.50	0.570	14.650	0.938	11.299	1.601	7.81	19.8	-
CB145N	9	119.0	34.97	14.50	0.571	14.649	0.938	11.199	1.651	7.81	19.6	-
CB146	7	115.0	33.82	14.15	0.551	15.145	0.882	10.965	1.595	8.59	19.9	-
14WF, B14d	6	111.0	32.65	14.37	0.540	14.620	0.873	11.299	1.536	8.37	20.9	-
14WF, CB145	11	111.0	32.65	14.37	0.540	14.620	0.873	11.299	1.536	8.37	20.9	-
CB145N	9	111.0	32.62	14.37	0.540	14.618	0.873	11.199	1.586	8.37	20.7	-
CB146	8	106.0	31.18	14.02	0.509	15.103	0.814	10.965	1.527	9.28	21.5	-
CB145	7	105.0	30.88	14.37	0.536	12.101	0.990	10.965	1.703	6.11	20.5	-
CB145N	9	103.0	30.27	14.25	0.498	14.576	0.813	11.199	1.526	8.96	22.5	-
14WF, CB145	11	103.0	30.26	14.25	0.495	14.575	0.813	11.299	1.476	8.96	22.8	-
14WF, B14d	6	103.0	30.26	14.25	0.495	14.575	0.813	11.299	1.476	8.96	22.8	-
CB146	8	96.0	28.23	13.87	0.462	15.056	0.738	10.965	1.451	10.20	23.7	-
14WF, CB145	11	95.0	27.94	14.12	0.465	14.545	0.748	11.299	1.411	9.72	24.3	-
14WF, B14d	6	95.0	27.94	14.12	0.465	14.545	0.748	11.299	1.411	9.72	24.3	-
CB145	7	95.0	27.93	14.19	0.485	12.050	0.898	10.965	1.611	6.71	22.6	-
CB145N	9	95.0	27.92	14.12	0.466	14.544	0.748	11.199	1.461	9.72	24.0	-
CB145N	9	87.0	25.56	14.00	0.422	14.500	0.688	11.199	1.401	10.54	26.5	-
14WF, B14d	6	87.0	25.56	14.00	0.420	14.500	0.688	11.299	1.351	10.54	26.9	-
14WF, CB145	11	87.0	25.56	14.00	0.420	14.500	0.688	11.299	1.351	10.54	26.9	-

Table 2.3.1 Dimensions and Primary Properties -- Steel Sections 1887-1952

Designation	X ₁ ksi	X ₂ x 106 (1/ksi) ²	Elastic Properties						Plastic Modulus	
			Axis x-x			Axis y-y			Z _x in.3	Z _y in.3
			I _x in.4	S _x in.3	r _x in.	I _y in.4	S _y in.3	r _y in.		
G15	2877	2048	815.3	109.6	6.36	115.8	21.6	2.40	120.5	35.1
G15	2893	2003	806.4	108.4	6.36	115.8	21.6	2.41	120.5	35.1
CB152N	3402	1173	760.0	100.3	6.26	60.5	16.0	1.77	113.0	24.8
B15a	3533	1012	758.1	100.0	6.25	55.6	14.8	1.69	112.9	23.6
G15	2746	2436	771.6	104.1	6.36	108.6	20.3	2.39	114.1	33.1
B15a	3738	958	666.8	88.9	5.95	40.8	11.3	1.47	103.9	19.1
B15a	3661	1045	664.9	88.6	5.95	41.9	11.6	1.49	103.4	19.3
CB152N	3109	1674	680.7	90.8	6.21	53.9	14.4	1.75	101.7	22.2
B15a	3236	1432	678.2	90.4	6.21	49.1	13.1	1.67	101.6	20.9
B15a	3348	1280	676.2	89.4	6.22	42.8	12.2	1.56	100.9	19.5
B15a	3369	1252	668.7	88.4	6.21	42.8	12.1	1.57	100.9	19.5
CB152N	2873	2275	620.4	83.4	6.19	48.9	13.1	1.74	93.0	20.2
B15a	3001	1920	618.4	83.1	6.19	44.2	11.8	1.65	92.9	19.0
B15a	3099	1718	617.0	82.3	6.20	38.6	11.0	1.55	92.3	17.6
B15a	3137	1641	610.0	81.3	6.20	38.3	10.9	1.55	92.4	17.6
B15a	3119	1677	609.5	81.3	6.20	38.6	11.0	1.56	92.3	17.6
B15a	3137	1641	610.0	81.3	6.20	38.3	10.9	1.55	92.4	17.6
B15a	3213	1481	610.5	81.4	6.21	37.2	10.6	1.53	92.6	17.3
B15a	2887	2286	563.3	75.7	6.16	34.7	10.0	1.53	84.7	16.0
B15a	2908	2226	555.8	74.7	6.16	34.7	10.0	1.54	84.7	16.0
B15	2719	2988	568.7	74.6	6.28	31.6	9.2	1.48	84.0	14.9
CB152N	2600	3551	569.6	74.7	6.29	34.9	10.2	1.56	83.9	15.8
B15a	2671	3147	508.2	68.9	6.11	30.8	8.9	1.50	76.9	14.3
B15	2700	3529	484.8	64.6	5.99	25.2	7.4	1.36	74.7	12.3
B15	2703	3479	484.6	64.6	5.99	24.2	7.1	1.34	74.8	12.0
B15	2466	4371	505.9	66.9	6.25	27.6	8.1	1.46	75.0	13.1
CB151N	2349	5275	507.1	67.1	6.26	30.9	9.1	1.55	74.9	14.0
B15	2397	4803	492.0	65.2	6.27	26.9	7.9	1.47	72.8	12.8
B15	2412	4700	486.8	64.5	6.27	26.9	7.9	1.47	72.8	12.8
B15	2507	4335	464.9	62.0	6.12	23.4	6.9	1.37	70.8	11.6
B15	2417	4888	456.7	60.9	6.16	24.0	7.2	1.41	69.1	11.7
B15	2279	5842	463.3	61.6	6.27	25.1	7.4	1.46	68.6	12.0
B15	2290	5729	458.1	61.0	6.26	25.1	7.4	1.47	68.6	12.0
CB151N	2105	8038	448.8	59.8	6.25	27.2	8.1	1.54	66.3	12.4
B15	2215	6577	447.0	59.6	6.25	23.9	7.1	1.45	66.3	11.5
B15	2206	6561	447.6	59.7	6.27	24.1	7.2	1.46	66.2	11.5
B15	2261	5979	442.6	59.0	6.27	23.4	7.0	1.44	66.3	11.4
B15	2222	6408	442.4	59.0	6.27	24.1	7.2	1.46	66.2	11.5
B15	2261	5979	442.6	59.0	6.27	23.4	7.0	1.44	66.3	11.4
B15	2328	5255	442.4	59.0	6.28	22.5	6.8	1.42	66.3	11.1
B65	2080	9416	405.5	54.1	6.10	19.9	5.9	1.35	61.2	9.8
B65	2080	9416	405.5	54.1	6.10	19.9	5.9	1.35	61.2	9.8
B35	2519	4096	405.1	54.0	6.17	13.5	4.9	1.13	60.3	8.2
B15	2070	8604	410.9	55.1	6.22	21.7	6.5	1.43	61.1	10.5
B15	2018	9651	396.3	53.3	6.19	20.6	6.1	1.41	59.1	10.0
CB151N	1897	12247	396.7	53.3	6.21	23.9	7.1	1.52	58.9	10.9
B24	2242	7424	367.9	49.0	6.00	11.6	4.2	1.06	55.3	7.1
14WF, CB145	4300	384	1593.0	216.0	6.31	567.7	77.0	3.77	240.8	116.9
14WF, B14d	4300	384	1593.0	216.0	6.31	567.7	77.0	3.77	240.8	116.9
CB145N	4321	377	1592.3	215.9	6.31	567.7	77.0	3.77	240.8	116.9
CB146	4258	394	1530.4	211.8	6.21	608.4	79.9	3.92	235.6	121.0
CB145N	4053	481	1476.0	201.9	6.29	527.6	71.8	3.76	224.1	108.9
14WF, CB145	4032	491	1476.7	202.0	6.29	527.6	71.8	3.76	224.0	108.9
14WF, B14d	4032	491	1476.7	202.0	6.29	527.6	71.8	3.76	224.0	108.9
CB146	3961	521	1402.1	196.0	6.18	559.4	73.7	3.90	216.9	111.5
14WF, CB145	3792	622	1373.1	189.4	6.26	491.8	67.1	3.75	209.1	101.7
14WF, B14d	3792	622	1373.1	189.4	6.26	491.8	67.1	3.75	209.1	101.7
CB145N	3811	610	1372.2	189.3	6.26	491.7	67.1	3.75	209.1	101.7
CB146	3661	707	1275.9	180.3	6.14	510.9	67.5	3.89	198.4	102.1
14WF, B14d	3549	806	1266.5	176.3	6.23	454.9	62.2	3.73	193.8	94.2
14WF, CB145	3549	806	1266.5	176.3	6.23	454.9	62.2	3.73	193.8	94.2
CB145N	3568	790	1265.3	176.1	6.23	454.7	62.2	3.73	193.8	94.2
CB146	3390	953	1164.1	166.1	6.11	467.6	61.9	3.87	181.9	93.6
CB145	4063	484	1169.6	162.8	6.15	292.6	48.4	3.08	180.9	73.4
CB145N	3324	1036	1165.4	163.6	6.20	419.8	57.6	3.72	179.1	87.1
14WF, CB145	3304	1062	1165.8	163.6	6.21	419.7	57.6	3.72	178.9	87.1
14WF, B14d	3304	1062	1165.8	163.6	6.21	419.7	57.6	3.72	178.9	87.1
CB146	3086	1373	1042.1	150.3	6.08	419.9	55.8	3.86	163.6	84.3
14WF, CB145	3060	1437	1063.5	150.6	6.17	383.7	52.8	3.71	164.0	79.8
14WF, B14d	3060	1437	1063.5	150.6	6.17	383.7	52.8	3.71	164.0	79.8
CB145	3699	695	1044.0	147.2	6.11	262.0	43.5	3.06	162.4	65.9
CB145N	3080	1401	1062.5	150.5	6.17	383.7	52.8	3.71	164.0	79.8
CB145N	2835	1928	966.2	138.0	6.15	349.7	48.2	3.70	149.6	72.9
14WF, B14d	2813	1987	966.9	138.1	6.15	349.7	48.2	3.70	149.5	72.9
14WF, CB145	2813	1987	966.9	138.1	6.15	349.7	48.2	3.70	149.5	72.9

Table 2.3.1 Dimensions and Primary Properties -- Steel Sections 1887-1952

Designation	Source Reference Number	Wt. per ft lb	Area	Depth	Web Thickness	Flange Width	Average Flange Thickness	Distance	Distance	Compact Section Criteria		
			A	d	t _w	b _f	t _f	T	k	b _f /2t _f	h/t _w	F _y "
			in.2	in.	in.	in.	in.	in.	in.	in.		
CB146	8	86.0	25.28	13.71	0.414	15.008	0.662	10.965	1.375	11.34	26.5	-
CB145	7	85.0	24.99	14.00	0.435	12.000	0.805	10.965	1.518	7.45	25.2	-
14WF, CB144	11	84.0	24.71	14.18	0.451	12.023	0.778	11.299	1.441	7.73	25.1	-
14WF, B14c	6	84.0	24.71	14.18	0.451	12.023	0.778	11.299	1.441	7.73	25.1	-
CB144N	9	84.0	24.68	14.18	0.451	12.021	0.778	11.199	1.491	7.73	24.8	-
CB144N	9	78.0	22.94	14.06	0.430	12.000	0.718	11.199	1.431	8.36	26.0	-
14WF, CB144	11	78.0	22.94	14.06	0.428	12.000	0.718	11.299	1.381	8.36	26.4	-
14WF, B14c	6	78.0	22.94	14.06	0.428	12.000	0.718	11.299	1.381	8.36	26.4	-
CB144	7	75.0	22.05	14.38	0.468	10.086	0.786	11.585	1.399	6.42	24.8	-
14WF, CB143	11	74.0	21.76	14.19	0.450	10.072	0.783	11.299	1.446	6.43	25.1	-
14WF, B14b	6	74.0	21.76	14.19	0.450	10.072	0.783	11.299	1.446	6.43	25.1	-
CB143N	9	74.0	21.75	14.19	0.451	10.071	0.783	11.199	1.496	6.43	24.8	-
CB143N	9	68.0	20.00	14.06	0.420	10.040	0.718	11.199	1.431	6.99	26.7	-
14WF, CB143	11	68.0	20.00	14.06	0.418	10.040	0.718	11.299	1.381	6.99	27.0	-
14WF, B14b	6	68.0	20.00	14.06	0.418	10.040	0.718	11.299	1.381	6.99	27.0	-
CB144	7	68.0	19.99	14.24	0.425	10.043	0.714	11.585	1.327	7.03	27.3	-
CB144	7	61.0	17.94	14.09	0.382	10.000	0.642	11.585	1.255	7.79	30.3	-
CB143N	9	61.0	17.94	13.91	0.380	10.000	0.643	11.199	1.356	7.78	29.5	-
14WF, CB143	11	61.0	17.94	13.91	0.378	10.000	0.643	11.299	1.306	7.78	29.9	-
14WF, B14b	6	61.0	17.94	13.91	0.378	10.000	0.643	11.299	1.306	7.78	29.9	-
CB143N	7	58.0	17.05	14.24	0.413	8.070	0.716	11.585	1.329	5.64	28.1	-
14WF, CB142	10	58.0	17.06	14.06	0.406	8.098	0.718	11.299	1.381	5.64	27.8	-
14WF, B14a	5	58.0	17.06	14.06	0.406	8.098	0.718	11.299	1.381	5.64	27.8	-
CB142N	9	58.0	17.03	14.06	0.406	8.096	0.718	11.199	1.431	5.64	27.6	-
CB143	7	53.0	15.59	14.12	0.378	8.035	0.656	11.585	1.269	6.12	30.6	-
14WF, CB142	11	53.0	15.59	13.94	0.370	8.062	0.658	11.299	1.321	6.13	30.5	-
14WF, B14a	6	53.0	15.59	13.94	0.370	8.062	0.658	11.299	1.321	6.13	30.5	-
CB142N	9	53.0	15.56	13.94	0.370	8.060	0.658	11.199	1.371	6.12	30.3	-
CB143	7	48.0	14.12	14.00	0.343	8.000	0.595	11.585	1.208	6.72	33.8	56
14WF, CB142	11	48.0	14.11	13.81	0.339	8.031	0.593	11.299	1.256	6.77	33.3	58
14WF, CB142	6	48.0	14.11	13.81	0.339	8.031	0.593	11.299	1.256	6.77	33.3	58
CB142N	9	48.0	14.10	13.81	0.340	8.030	0.593	11.199	1.306	6.77	32.9	59
14WF, CB142	11	43.0	12.65	13.68	0.308	8.000	0.528	11.299	1.191	7.58	36.7	48
14WF, B14a	6	43.0	12.65	13.68	0.308	8.000	0.528	11.299	1.191	7.58	36.7	48
CB142N	9	43.0	12.64	13.68	0.310	8.000	0.528	11.199	1.241	7.58	36.1	49
B14	2	42.0	12.46	14.25	0.340	6.825	0.578	12.030	1.110	5.90	35.4	51
B14	1	42.0	12.40	14.12	0.340	6.790	0.580	11.896	1.112	5.85	35.0	53
B14	4	42.0	12.38	14.25	0.335	6.820	0.578	12.030	1.110	5.90	35.9	50
CB141N	9	42.0	12.35	14.25	0.333	6.818	0.578	12.169	1.041	5.90	36.5	48
CB142	7	42.0	12.35	14.24	0.342	6.822	0.569	12.177	1.032	5.99	35.6	51
14WF, CB141	10	42.0	12.34	14.24	0.338	6.801	0.573	12.109	1.066	5.93	35.8	50
14WF, B14	5	42.0	12.34	14.24	0.338	6.801	0.573	12.300	0.970	5.93	36.4	49
CB142	7	39.0	11.47	14.16	0.318	6.798	0.529	12.177	0.992	6.43	38.3	44
14WF	12	38.1	11.18	13.88	0.389	6.852	0.440	12.201	0.837	7.79	31.4	-
CB142	7	38.0	11.18	14.00	0.375	6.855	0.449	12.177	0.912	7.63	32.5	61
14WF, CB141	11	38.0	11.17	14.12	0.313	6.776	0.513	12.109	1.006	6.60	38.7	43
14WF, B14	6	38.0	11.17	14.12	0.313	6.776	0.513	12.300	0.910	6.60	39.3	42
B14	2	37.5	11.07	14.12	0.305	6.790	0.513	12.030	1.045	6.62	39.4	41
B14	1	37.5	11.02	14.00	0.300	6.750	0.520	11.896	1.052	6.49	39.7	41
B14	4	37.0	10.93	14.12	0.295	6.780	0.513	12.030	1.045	6.61	40.8	39
CB141N	9	37.0	10.87	14.12	0.291	6.776	0.513	12.169	0.976	6.60	41.8	37
CB142	7	36.0	10.58	14.08	0.294	6.774	0.489	12.177	0.952	6.93	41.4	38
14WF, CB141	11	34.0	10.00	14.00	0.287	6.750	0.453	12.109	0.946	7.45	42.2	36
14WF, B14	6	34.0	10.00	14.00	0.287	6.750	0.453	12.300	0.850	7.45	42.9	35
B14	1	33.0	9.73	13.88	0.265	6.715	0.460	11.896	0.992	7.30	44.9	32
CB142	7	33.0	9.71	14.00	0.270	6.750	0.449	12.177	0.912	7.52	45.1	32
B14	3	33.0	9.70	14.00	0.265	6.750	0.453	12.030	0.985	7.45	45.4	31
CB141N	9	33.0	9.69	14.00	0.265	6.750	0.453	12.169	0.916	7.45	45.9	31
14WF	12	32.4	9.53	13.88	0.270	6.733	0.440	12.201	0.837	7.65	45.2	32
B14	3	30.0	8.89	13.88	0.265	6.750	0.393	12.030	0.925	8.59	45.4	31
CB141	7	30.0	8.82	13.96	0.270	6.000	0.431	12.177	0.894	6.96	45.1	32
CB141N	9	30.0	8.81	13.88	0.260	6.745	0.393	12.169	0.856	8.58	46.8	29
14WF, CB141	11	30.0	8.81	13.86	0.270	6.733	0.383	12.109	0.876	8.79	44.8	32
14WF, B14	6	30.0	8.81	13.86	0.270	6.733	0.383	12.300	0.780	8.79	45.6	31
----		26.0	7.65	13.89	0.255	5.025	0.418	12.069	0.911	6.01	47.3	29
----		22.0	6.47	13.72	0.230	5.000	0.335	12.065	0.828	7.46	52.5	23
----		17.2	5.05	14.00	0.210	4.000	0.272	12.331	0.835	7.35	58.7	19
CB125N	19	85.0	24.98	12.50	0.501	12.106	0.796	9.583	1.459	7.60	19.1	-
12WF, CB124	21	85.0	24.98	12.50	0.495	12.105	0.796	9.583	1.459	7.60	19.4	-
12WF, B12c	11	85.0	24.98	12.50	0.495	12.105	0.796	9.583	1.459	7.60	19.4	-
CB124	16	83.0	24.41	12.00	0.704	10.196	0.830	9.115	1.443	6.14	12.9	-
CB124C	18	82.0	24.11	12.00	0.453	12.000	0.800	9.175	1.413	7.50	20.3	-
CB125N	19	79.0	23.22	12.38	0.476	12.081	0.736	9.583	1.399	8.21	20.1	-
12WF, CB124	21	79.0	23.22	12.38	0.470	12.080	0.736	9.583	1.399	8.21	20.4	-
12WF, B14C	11	79.0	23.22	12.38	0.470	12.080	0.736	9.583	1.399	8.21	20.4	-

Table 2.3.1 Dimensions and Primary Properties -- Steel Sections 1887-1952

Designation	X ₁ ksi	X ₂ x 106 (1/ksi) ²	Elastic Properties						Plastic Modulus	
			Axis x-x			Axis y-y			Z _x in.3	Z _y in.3
			I _x	S _x	r _x	I _y	S _y	r _y		
			in.4	in.3	in.	in.4	in.3	in.		
CB146	2780	2060	923.0	134.6	6.04	373.1	49.7	3.84	145.6	75.1
CB145	3333	1042	921.3	131.6	6.07	232.0	38.7	3.05	144.2	58.5
14WF, CB144	3193	1261	928.4	130.9	6.13	225.5	37.5	3.02	143.3	56.9
14WF, B14c	3193	1261	928.4	130.9	6.13	225.5	37.5	3.02	143.3	56.9
CB144N	3213	1228	927.2	130.8	6.13	225.4	37.5	3.02	143.3	56.9
CB144N	2997	1623	850.5	121.0	6.09	206.9	34.5	3.00	132.1	52.3
14WF, CB144	2972	1678	851.2	121.1	6.09	206.9	34.5	3.00	132.0	52.3
14WF, B14c	2972	1678	851.2	121.1	6.09	206.9	34.5	3.00	132.0	52.3
CB144	3249	1259	823.5	114.5	6.11	134.5	26.7	2.47	127.0	40.7
14WF, CB143	3266	1215	796.8	112.3	6.05	133.5	26.5	2.48	123.7	40.4
14WF, B14b	3266	1215	796.8	112.3	6.05	133.5	26.5	2.48	123.7	40.4
CB143N	3293	1177	795.9	112.2	6.05	133.4	26.5	2.48	123.7	40.3
CB143N	3045	1602	723.4	102.9	6.01	121.2	24.1	2.46	112.9	36.7
14WF, CB143	3015	1664	724.1	103.0	6.02	121.2	24.1	2.46	112.8	36.7
14WF, B14b	3015	1664	724.1	103.0	6.02	121.2	24.1	2.46	112.8	36.7
CB144	2962	1806	738.8	103.8	6.08	120.6	24.0	2.46	114.4	36.6
CB144	2676	2684	656.2	93.1	6.05	107.1	21.4	2.44	102.0	32.6
CB143N	2753	2381	640.8	92.1	5.98	107.3	21.5	2.45	100.4	32.6
14WF, CB143	2722	2487	641.5	92.2	5.98	107.3	21.5	2.45	100.4	32.6
14WF, B14b	2722	2487	641.5	92.2	5.98	107.3	21.5	2.45	100.4	32.6
CB143N	3024	1777	609.4	85.6	5.98	62.8	15.6	1.92	95.1	23.9
14WF, CB142	3072	1648	597.9	85.0	5.92	63.7	15.7	1.93	93.8	24.1
14WF, B14a	3072	1648	597.9	85.0	5.92	63.7	15.7	1.93	93.8	24.1
CB142N	3102	1584	596.7	84.9	5.92	63.6	15.7	1.93	93.7	24.1
CB143	2785	2455	552.5	78.2	5.95	56.8	14.1	1.91	86.5	21.6
14WF, CB142	2824	2282	542.1	77.8	5.90	57.5	14.3	1.92	85.2	21.8
14WF, B14a	2824	2282	542.1	77.8	5.90	57.5	14.3	1.92	85.2	21.8
CB142N	2858	2178	541.1	77.6	5.90	57.5	14.3	1.92	85.2	21.8
CB143	2536	3526	496.0	70.9	5.93	50.8	12.7	1.90	77.9	19.4
14WF, CB142	2573	3296	484.9	70.2	5.86	51.3	12.8	1.91	76.5	19.5
14WF, CB142	2573	3296	484.9	70.2	5.86	51.3	12.8	1.91	76.5	19.5
CB142N	2609	3123	484.0	70.1	5.86	51.2	12.8	1.91	76.5	19.5
14WF, CB142	2324	4948	429.0	62.7	5.82	45.1	11.3	1.89	67.8	17.2
14WF, B14a	2324	4948	429.0	62.7	5.82	45.1	11.3	1.89	67.8	17.2
CB142N	2363	4629	428.3	62.6	5.82	45.1	11.3	1.89	67.9	17.2
B14	2564	3658	436.5	61.3	5.92	27.3	8.0	1.48	68.5	12.9
B14	2595	3480	426.8	60.5	5.87	27.0	7.9	1.48	67.6	12.8
B14	2553	3697	435.3	61.1	5.93	27.2	8.0	1.48	68.2	12.9
CB141N	2411	4631	435.3	61.1	5.94	30.6	9.0	1.57	68.2	13.8
CB142	2405	4752	431.5	60.6	5.91	30.2	8.8	1.56	67.7	13.6
14WF, CB141	2422	4598	432.2	60.7	5.92	28.1	8.3	1.51	67.7	13.6
14WF, B14	2476	4207	432.2	60.7	5.92	28.1	8.3	1.51	67.7	13.6
CB142	2240	6269	398.3	56.3	5.89	27.7	8.2	1.56	62.7	12.6
14WF	2492	4812	346.7	49.9	5.57	19.2	5.6	1.31	56.9	10.8
CB142	2206	7608	357.5	51.1	5.66	24.2	7.1	1.47	57.8	11.0
14WF, CB141	2201	6767	385.3	54.6	5.87	24.6	7.3	1.49	60.7	12.1
14WF, B14	2260	6081	385.3	54.6	5.87	24.6	7.3	1.49	60.7	12.1
B14	2311	5524	383.7	54.3	5.89	23.4	6.9	1.46	60.4	11.2
B14	2341	5182	377.4	53.9	5.85	23.4	6.9	1.46	59.9	11.2
B14	2287	5674	381.3	54.0	5.91	23.3	6.9	1.46	59.9	11.1
CB141N	2141	7337	380.9	53.9	5.92	26.6	7.9	1.57	59.8	12.1
CB142	2079	8408	365.6	51.9	5.88	25.4	7.5	1.55	57.6	11.5
14WF, CB141	1979	10408	339.2	48.5	5.83	21.3	6.3	1.46	53.7	10.6
14WF, B14	2045	9131	339.2	48.5	5.83	21.3	6.3	1.46	53.7	10.6
B14	2097	7966	330.3	47.6	5.83	20.0	6.0	1.43	52.5	9.7
CB142	1917	11589	333.4	47.6	5.86	23.0	6.8	1.54	52.7	10.5
B14	2056	8660	334.3	47.8	5.87	19.9	5.9	1.43	52.7	9.6
CB141N	1916	11450	334.7	47.8	5.88	23.2	6.9	1.55	52.8	10.5
14WF	2126	7734	320.2	46.1	5.79	18.1	5.4	1.38	51.2	10.2
B14	1904	12393	294.9	42.5	5.76	16.8	5.0	1.38	47.1	8.2
CB141	1902	12752	292.0	41.8	5.75	15.5	5.2	1.33	46.6	8.0
CB141N	1744	17401	294.3	42.4	5.78	20.1	6.0	1.51	46.9	9.2
14WF, CB141	1760	17237	289.6	41.8	5.73	17.5	5.2	1.41	46.3	8.9
14WF, B14	1836	14545	289.6	41.8	5.73	17.5	5.2	1.41	46.3	8.9
----	1908	13474	242.6	34.9	5.63	8.3	3.3	1.04	39.2	5.5
----	1632	26080	197.4	28.8	5.52	6.4	2.6	0.99	32.2	4.4
----	1571	36623	147.3	21.0	5.40	2.7	1.3	0.72	24.4	2.3
CB125N	3805	626	722.0	115.5	5.38	235.5	38.9	3.07	127.7	59.0
12WF, CB124	3790	634	723.3	115.7	5.38	235.5	38.9	3.07	127.5	59.0
12WF, B12c	3790	634	723.3	115.7	5.38	235.5	38.9	3.07	127.5	59.0
CB124	4668	322	598.9	99.8	4.95	147.0	28.8	2.45	113.3	44.4
CB124C	3893	552	650.8	108.5	5.20	230.5	38.4	3.09	119.8	58.1
CB125N	3552	823	661.9	106.9	5.34	216.4	35.8	3.05	117.7	54.3
12WF, CB124	3536	835	663.0	107.1	5.34	216.4	35.8	3.05	117.5	54.3
12WF, B14C	3536	835	663.0	107.1	5.34	216.4	35.8	3.05	117.5	54.3

Table 2.3.1 Dimensions and Primary Properties -- Steel Sections 1887-1952

Designation	Source Reference Number	Wt. per ft lb	Area	Depth	Web Thickness	Flange Width	Average Flange Thickness	Distance	Distance	Compact Section Criteria		
			A	d	t _w	b _f	t _f	T	k	b _f /2t _f	h/t _w	F _y "
			in.2	in.	in.	in.	in.	in.	in.	in.		
G12a	7	76.5	22.50	12.12	0.510	10.290	0.824	9.021	1.549	6.25	17.7	-
G12a	4	76.5	22.29	12.12	0.510	10.290	0.824	9.021	1.549	6.25	17.7	-
CB124B	18	76.0	22.35	12.00	0.670	12.270	0.608	9.559	1.221	10.09	14.3	-
CB124	16	75.0	22.05	12.00	0.508	10.000	0.830	9.115	1.443	6.02	17.9	-
12WF, CB124	21	72.0	21.16	12.25	0.430	12.040	0.671	9.583	1.334	8.97	22.3	-
12WF, B12c	11	72.0	21.16	12.25	0.430	12.040	0.671	9.583	1.334	8.97	22.3	-
CB125N	19	72.0	21.15	12.25	0.436	12.041	0.671	9.583	1.334	8.97	22.0	-
G12a	7	70.5	20.79	12.00	0.470	12.250	0.764	9.021	1.489	8.02	19.2	-
G12a	4	70.5	20.57	12.00	0.470	10.250	0.764	9.021	1.489	6.71	19.2	-
G12a	1	70.0	20.60	12.00	0.445	10.000	0.799	8.761	1.619	6.26	19.7	-
CB124B	18	70.0	20.58	12.00	0.523	12.123	0.608	9.559	1.221	9.97	18.3	-
G12a	2	70.0	20.58	12.00	0.460	10.000	0.790	8.947	1.526	6.33	19.5	-
CB123B	18	66.0	19.41	12.26	0.448	9.073	0.795	9.445	1.408	5.71	21.1	-
G12a	7	66.0	19.32	11.88	0.450	10.230	0.704	9.021	1.429	7.27	20.0	-
G12a	4	66.0	19.11	11.88	0.450	10.230	0.704	9.021	1.429	7.27	20.0	-
12WF, CB124	21	65.0	19.11	12.12	0.390	12.000	0.606	9.583	1.269	9.90	24.6	-
12WF, B12c	11	65.0	19.11	12.12	0.390	12.000	0.606	9.583	1.269	9.90	24.6	-
CB124B	18	65.0	19.11	12.00	0.400	12.000	0.608	9.559	1.221	9.87	23.9	-
CB125N	19	65.0	19.09	12.12	0.395	12.000	0.606	9.583	1.269	9.90	24.3	-
12WF, CB123	20	64.0	18.83	12.31	0.405	10.060	0.701	9.583	1.364	7.18	23.7	-
12WF, B12b	10	64.0	18.83	12.31	0.405	10.060	0.701	9.583	1.364	7.18	23.7	-
CB124N	19	64.0	18.81	12.31	0.409	10.060	0.701	9.583	1.364	7.18	23.4	-
G12	7	61.0	17.92	12.12	0.410	10.030	0.666	9.511	1.305	7.54	23.2	-
G12	4	61.0	17.77	12.12	0.410	10.030	0.666	9.511	1.305	7.54	23.2	-
CB123B	18	60.0	17.65	12.12	0.409	9.034	0.724	9.445	1.337	6.24	23.1	-
G12	9	60.0	17.62	12.12	0.390	10.020	0.662	9.517	1.302	7.57	24.4	-
12WF, B12b	11	58.0	17.06	12.19	0.359	10.014	0.641	9.583	1.304	7.81	26.7	-
12WF, CB123	21	58.0	17.06	12.19	0.359	10.014	0.641	9.583	1.304	7.81	26.7	-
CB124N	19	58.0	17.04	12.19	0.363	10.014	0.641	9.583	1.304	7.81	26.4	-
G12	7	55.5	16.35	12.00	0.380	10.000	0.606	9.511	1.245	8.26	25.0	-
G12	4	55.5	16.21	12.00	0.380	10.000	0.606	9.511	1.245	8.26	25.0	-
G12	9	55.0	16.18	12.00	0.370	10.000	0.602	9.517	1.242	8.31	25.7	-
G12	2	55.0	16.18	12.00	0.370	9.750	0.626	9.449	1.276	7.79	25.5	-
CB123B	18	55.0	16.17	12.00	0.375	9.000	0.665	9.445	1.278	6.77	25.2	-
G12	1	55.0	16.12	12.00	0.350	9.750	0.634	9.267	1.367	7.69	26.5	-
12WF, B12b	11	53.0	15.59	12.06	0.345	10.000	0.576	9.583	1.239	8.68	27.8	-
12WF, CB123	21	53.0	15.59	12.06	0.345	10.000	0.576	9.583	1.239	8.68	27.8	-
CB124N	19	53.0	15.57	12.06	0.349	10.000	0.576	9.583	1.239	8.68	27.5	-
G12	7	51.5	15.21	11.91	0.360	9.980	0.561	9.511	1.200	8.90	26.4	-
G12	4	51.5	15.07	11.91	0.360	9.980	0.561	9.511	1.200	8.90	26.4	-
12WF, B12a	11	50.0	14.71	12.19	0.371	8.077	0.641	9.583	1.304	6.30	25.8	-
12WF, CB122	21	50.0	14.71	12.19	0.371	8.077	0.641	9.583	1.304	6.30	25.8	-
CB123	17	50.0	14.69	12.26	0.361	8.071	0.655	9.823	1.218	6.16	27.2	-
CB123N	19	50.0	14.69	12.19	0.375	8.077	0.641	9.583	1.304	6.30	25.6	-
B12a	7	48.5	14.28	12.25	0.395	6.815	0.727	9.736	1.257	4.69	24.6	-
12WF, B12a	11	45.0	13.24	12.06	0.336	8.042	0.576	9.583	1.239	6.98	28.5	-
12WF, CB122	21	45.0	13.24	12.06	0.336	8.042	0.576	9.583	1.239	6.98	28.5	-
CB123	17	45.0	13.23	12.13	0.326	8.036	0.591	9.823	1.154	6.80	30.1	-
CB123N	19	45.0	13.21	12.06	0.340	8.042	0.576	9.583	1.239	6.98	28.2	-
B12a	6	44.5	13.10	12.25	0.375	6.445	0.692	9.820	1.215	4.66	26.2	-
B12a	7	44.0	12.97	12.12	0.360	6.780	0.662	9.736	1.192	5.12	27.0	-
B12a	6	40.0	11.84	12.12	0.340	6.410	0.627	9.820	1.150	5.12	28.9	-
B12a	7	40.0	11.80	12.00	0.330	6.750	0.602	9.820	1.090	5.61	29.8	-
12WF, B12a	11	40.0	11.77	11.94	0.294	8.000	0.516	9.583	1.179	7.75	32.6	61
12WF, CB122	21	40.0	11.77	11.94	0.294	8.000	0.516	9.583	1.179	7.75	32.6	61
CB123	17	40.0	11.76	12.00	0.290	8.000	0.526	9.823	1.089	7.60	33.9	56
CB123N	19	40.0	11.75	11.94	0.298	8.000	0.516	9.583	1.179	7.75	32.2	62
B12a	5	36.5	10.60	12.00	0.310	6.380	0.567	9.820	1.090	5.63	31.7	64
B12a	1	36.0	10.63	12.00	0.310	6.300	0.577	9.661	1.169	5.46	31.2	-
B12a	3	36.0	10.61	12.00	0.310	6.300	0.575	9.786	1.107	5.48	31.6	65
CB122	17	36.0	10.59	12.24	0.308	6.568	0.538	10.335	0.951	6.10	33.6	57
12WF, B12	11	36.0	10.59	12.24	0.305	6.565	0.540	10.450	0.895	6.08	34.3	55
12WF, CB121	21	36.0	10.59	12.24	0.305	6.565	0.540	10.295	0.973	6.08	33.8	57
CB122N	19	36.0	10.58	12.25	0.300	6.560	0.545	10.335	0.958	6.02	34.5	54
B12	8	36.0	10.58	12.25	0.300	6.555	0.545	10.190	1.030	6.01	34.0	56
CB122	17	34.0	9.99	12.02	0.375	6.635	0.431	10.335	0.844	7.70	27.6	-
12WF	24	32.5	9.54	12.00	0.310	6.570	0.456	10.294	0.853	7.20	33.2	58
B12	3	32.0	9.44	12.00	0.335	6.205	0.462	10.102	0.949	6.72	30.2	-
CB122N	19	32.0	9.42	12.12	0.275	6.535	0.480	10.335	0.892	6.81	37.6	46
B12	9	32.0	9.42	12.12	0.275	6.530	0.480	10.190	0.965	6.80	37.1	47
12WF, B12	10	32.0	9.41	12.12	0.273	6.533	0.480	10.450	0.835	6.81	38.3	44
12WF, CB121	20	32.0	9.41	12.12	0.273	6.533	0.480	10.295	0.913	6.81	37.7	45
CB122	17	32.0	9.40	12.12	0.274	6.534	0.479	10.335	0.892	6.82	37.7	45
B12	7	31.5	9.36	12.12	0.270	6.525	0.480	10.190	0.965	6.80	37.7	45
B12	1	31.0	9.13	12.00	0.310	6.160	0.463	10.000	1.000	6.66	32.3	62

Table 2.3.1 Dimensions and Primary Properties – Steel Sections 1887-1952

Designation	X ₁ ksi	X ₂ x 106 (1/ksi) ²	Elastic Properties						Plastic Modulus	
			Axis x-x			Axis y-y			Z _x in.3	Z _y in.3
			I _x in.4	S _x in.3	r _x in.	I _y in.4	S _y in.3	r _y in.		
			in.4	in.3	in.	in.4	in.3	in.		
G12a	4390	370	594.2	98.1	5.14	132.1	25.7	2.42	109.6	41.0
G12a	4409	364	589.0	97.2	5.14	132.1	25.7	2.43	109.6	41.0
CB124B	3652	855	560.2	93.4	5.01	187.5	30.6	2.90	104.5	47.0
CB124	4197	443	570.7	95.1	5.09	138.5	27.7	2.51	106.3	42.2
12WF, CB124	3240	1174	597.4	97.5	5.31	195.3	32.4	3.04	106.3	49.1
12WF, B12c	3240	1174	597.4	97.5	5.31	195.3	32.4	3.04	106.3	49.1
CB125N	3255	1156	596.2	97.3	5.31	195.3	32.4	3.04	106.5	49.2
G12a	4454	346	543.6	90.6	5.11	119.7	23.4	2.40	117.8	53.2
G12a	4118	473	538.4	89.7	5.12	119.7	23.4	2.41	100.7	37.4
G12a	4393	360	540.9	90.2	5.12	109.5	21.9	2.31	101.2	35.9
CB124B	3239	1269	539.0	89.8	5.12	180.7	29.8	2.96	99.2	45.4
G12a	4238	419	538.8	89.8	5.12	114.7	22.9	2.36	100.8	36.8
CB123B	3876	610	525.7	85.8	5.50	99.1	21.8	2.26	95.4	33.3
G12a	3846	623	496.9	83.7	5.07	108.3	21.2	2.37	92.6	34.1
G12a	3867	610	491.7	82.8	5.07	108.3	21.2	2.38	92.6	34.1
12WF, CB124	2942	1709	533.4	88.0	5.28	174.6	29.1	3.02	95.3	44.0
12WF, B12c	2942	1709	533.4	88.0	5.28	174.6	29.1	3.02	95.3	44.0
CB124B	2981	1627	521.3	86.9	5.22	175.2	29.2	3.03	94.7	44.2
CB125N	2955	1684	532.0	87.8	5.28	174.6	29.1	3.02	95.5	44.1
12WF, CB123	3367	1035	528.3	85.8	5.29	119.0	23.7	2.51	93.9	35.9
12WF, B12b	3367	1035	528.3	85.8	5.29	119.0	23.7	2.51	93.9	35.9
CB124N	3375	1025	527.5	85.7	5.30	119.0	23.7	2.52	94.0	35.9
G12	3494	909	483.6	79.8	5.20	95.9	19.1	2.31	88.3	30.8
G12	3506	895	479.9	79.2	5.20	95.8	19.1	2.32	88.3	30.8
CB123B	3549	860	472.0	77.9	5.17	89.0	19.7	2.25	86.2	30.0
G12	3440	953	479.1	79.1	5.21	94.9	18.9	2.32	87.2	30.5
12WF, B12b	3072	1463	476.1	78.1	5.28	107.4	21.4	2.51	84.8	32.5
12WF, CB123	3072	1463	476.1	78.1	5.28	107.4	21.4	2.51	84.8	32.5
CB124N	3080	1448	475.3	78.0	5.28	107.4	21.4	2.51	84.9	32.5
G12	3229	1240	435.6	72.6	5.16	84.9	17.0	2.28	79.9	27.6
G12	3242	1220	431.8	72.0	5.16	84.9	17.0	2.29	79.9	27.6
G12	3196	1284	432.5	72.1	5.17	84.3	16.9	2.28	79.3	27.4
G12	3333	1084	432.0	72.0	5.17	81.1	16.6	2.24	80.0	27.0
CB123B	3271	1178	428.4	71.4	5.15	80.9	18.0	2.24	78.5	27.3
G12	3496	888	432.0	72.0	5.18	76.1	15.6	2.17	80.1	26.1
12WF, B12b	2816	2087	426.2	70.7	5.23	96.1	19.2	2.48	76.4	29.1
12WF, CB123	2816	2087	426.2	70.7	5.23	96.1	19.2	2.48	76.4	29.1
CB124N	2829	2057	425.4	70.5	5.23	96.1	19.2	2.48	76.5	29.1
G12	3037	1584	400.6	67.3	5.13	76.9	15.4	2.25	73.8	25.2
G12	3055	1552	396.9	66.6	5.13	76.9	15.4	2.26	73.8	25.2
12WF, B12a	3175	1389	394.5	64.7	5.18	56.4	14.0	1.96	70.8	21.3
12WF, CB122	3175	1389	394.5	64.7	5.18	56.4	14.0	1.96	70.8	21.3
CB123	3145	1422	400.5	65.4	5.22	57.5	14.2	1.98	72.2	21.7
CB123N	3190	1368	393.0	64.5	5.17	56.4	14.0	1.96	70.9	21.3
B12a	3701	797	373.2	60.9	5.11	35.1	10.3	1.57	68.5	16.4
12WF, B12a	2877	2040	350.8	58.2	5.15	50.0	12.4	1.94	63.2	18.9
12WF, CB122	2877	2040	350.8	58.2	5.15	50.0	12.4	1.94	63.2	18.9
CB123	2857	2073	356.9	58.8	5.19	51.2	12.7	1.97	64.6	19.4
CB123N	2896	1998	349.3	57.9	5.14	50.0	12.4	1.95	63.3	18.9
B12a	3518	988	340.9	55.7	5.10	28.3	8.8	1.47	62.6	14.0
B12a	3393	1116	335.1	55.3	5.08	31.1	9.2	1.55	61.8	14.6
B12a	3213	1407	304.6	50.3	5.07	24.9	7.8	1.45	56.2	12.4
B12a	3094	1605	301.2	50.2	5.05	27.6	8.2	1.53	55.9	13.1
12WF, B12a	2588	3065	310.1	51.9	5.13	44.1	11.0	1.94	55.9	16.7
12WF, CB122	2588	3065	310.1	51.9	5.13	44.1	11.0	1.94	55.9	16.7
CB123	2556	3195	313.7	52.3	5.17	44.9	11.2	1.95	57.0	17.1
CB123N	2603	3007	308.6	51.7	5.13	44.1	11.0	1.94	56.0	16.8
B12a	2955	1957	269.2	44.9	5.04	21.9	6.9	1.44	50.4	11.0
B12a	3093	1628	270.2	45.0	5.04	20.4	6.5	1.38	50.6	10.6
B12a	3005	1831	269.2	44.9	5.04	21.3	6.8	1.42	50.5	10.9
CB122	2586	3351	280.1	45.8	5.14	25.4	7.7	1.55	50.9	11.9
12WF, B12	2655	3002	280.8	45.9	5.15	23.7	7.2	1.50	51.0	11.9
12WF, CB121	2595	3293	280.8	45.9	5.15	23.7	7.2	1.50	51.0	11.9
CB122N	2592	3276	282.3	46.1	5.17	25.7	7.8	1.56	51.2	12.0
B12	2749	2598	281.8	46.0	5.16	22.7	6.9	1.46	51.1	11.1
CB122	2475	4670	238.1	39.6	4.88	21.0	6.3	1.45	44.8	9.9
12WF	2609	3402	238.1	39.7	5.00	17.8	5.4	1.37	44.1	10.1
B12	2644	3424	228.5	38.1	4.92	16.0	5.2	1.30	43.3	8.4
CB122N	2313	5165	247.0	40.8	5.12	22.3	6.8	1.54	45.1	10.5
B12	2473	3974	246.4	40.7	5.11	19.4	5.9	1.44	45.0	9.6
12WF, B12	2389	4557	246.8	40.7	5.12	20.6	6.3	1.48	45.0	10.5
12WF, CB121	2323	5096	246.8	40.7	5.12	20.6	6.3	1.48	45.0	10.5
CB122	2309	5210	246.3	40.7	5.12	22.3	6.8	1.54	45.0	10.4
B12	2466	4007	245.7	40.5	5.12	19.4	5.9	1.44	44.8	9.6
B12	2646	3297	225.2	37.5	4.97	14.7	4.8	1.27	42.3	8.0

Table 2.3.1 Dimensions and Primary Properties -- Steel Sections 1887-1952

Designation	Source Reference Number	Wt. per ft lb	Area	Depth	Web Thickness	Flange Width	Average Flange Thickness	Distance	Distance	Compact Section Criteria		
			A	d	t _w	b _f	t _f	T	k	b _f /2t _f	h/t _w	F _y ^{''}
			in.2	in.	in.	in.	in.	in.	in.	in.		ksi
12WF, B12	12	31.0	9.12	12.09	0.265	6.525	0.465	10.450	0.820	7.02	39.4	41
12WF, CB121	22	31.0	9.12	12.09	0.265	6.525	0.465	10.295	0.898	7.02	38.8	43
B12	5	31.0	9.02	12.06	0.270	6.270	0.480	10.140	0.960	6.53	37.6	46
12WF	24	29.6	8.70	12.00	0.240	6.500	0.456	10.294	0.853	7.13	42.9	35
B12	3	28.5	8.42	12.00	0.250	6.120	0.462	10.102	0.949	6.62	40.4	39
B12	1	28.5	8.41	12.00	0.250	6.100	0.463	10.000	1.000	6.59	40.0	40
B12	5	28.5	8.40	12.00	0.250	6.250	0.450	10.140	0.930	6.94	40.6	39
B12	7	28.0	8.28	12.00	0.245	6.500	0.420	10.190	0.905	7.74	41.6	37
12WF, B12	10	28.0	8.23	12.00	0.240	6.500	0.420	10.450	0.775	7.74	43.5	34
12WF, CB121	20	28.0	8.23	12.00	0.240	6.500	0.420	10.295	0.853	7.74	42.9	35
CB122	17	28.0	8.22	12.00	0.240	6.500	0.420	10.335	0.833	7.74	43.1	35
CB122N	19	28.0	8.22	12.00	0.240	6.500	0.420	10.335	0.833	7.74	43.1	35
B66	14	28.0	8.15	12.00	0.284	6.000	0.410	10.360	0.820	7.32	36.5	48
B66	15	27.9	8.15	12.00	0.284	6.000	0.410	10.360	0.820	7.32	36.5	48
B36	13	27.5	8.04	12.00	0.255	5.000	0.513	9.786	1.107	4.88	38.4	44
12WF, CB121	22	27.0	7.97	11.96	0.240	6.500	0.400	10.295	0.833	8.13	42.9	35
12WF, B12	12	27.0	7.97	11.96	0.240	6.500	0.400	10.450	0.755	8.13	43.5	34
B12	7	25.0	7.44	11.88	0.240	6.495	0.360	10.190	0.845	9.02	42.5	36
12WF, B12	10	25.0	7.39	11.87	0.240	6.500	0.355	10.450	0.710	9.15	43.5	34
12WF, CB121	20	25.0	7.39	11.87	0.240	6.500	0.355	10.295	0.788	9.15	42.9	35
B12	9	25.0	7.38	11.87	0.240	6.495	0.355	10.190	0.840	9.15	42.5	36
B12	6	25.0	7.37	11.84	0.240	6.240	0.370	10.140	0.850	8.43	42.2	36
CB122N	19	25.0	7.36	11.87	0.240	6.500	0.354	10.335	0.767	9.18	43.1	35
B25	23	25.0	7.35	12.00	0.270	5.000	0.420	10.284	0.858	5.95	38.1	44
CB121	17	25.0	7.34	11.92	0.240	6.000	0.382	10.335	0.794	7.85	43.1	35
CB103N	17	66.0	19.43	10.38	0.460	10.120	0.748	7.659	1.361	6.76	16.7	-
10WF, CB103	19	66.0	19.41	10.38	0.457	10.117	0.748	7.759	1.311	6.76	17.0	-
10WF, B10b	10	66.0	19.41	10.38	0.457	10.117	0.748	7.759	1.311	6.76	17.0	-
CB103A	16	64.0	18.81	10.00	0.791	10.441	0.558	7.859	1.071	9.36	9.9	-
CB103	14	63.0	18.53	10.00	0.787	9.412	0.610	7.755	1.123	7.71	9.9	-
10WF, CB103	19	60.0	17.66	10.25	0.415	10.075	0.683	7.759	1.246	7.38	18.7	-
10WF, B10b	10	60.0	17.66	10.25	0.415	10.075	0.683	7.759	1.246	7.38	18.7	-
CB103N	17	60.0	17.65	10.25	0.415	10.075	0.683	7.659	1.296	7.38	18.5	-
CB103A	16	59.0	17.34	10.00	0.644	10.294	0.558	7.859	1.071	9.22	12.2	-
CB103	14	56.0	16.47	10.00	0.581	9.206	0.610	7.755	1.123	7.55	13.3	-
CB103N	17	54.0	15.89	10.12	0.370	10.030	0.618	7.659	1.231	8.11	20.7	-
10WF, CB103	19	54.0	15.88	10.12	0.368	10.028	0.618	7.759	1.181	8.11	21.1	-
10WF, B10b	10	54.0	15.88	10.12	0.368	10.028	0.618	7.759	1.181	8.11	21.1	-
CB103A	16	54.0	15.87	10.00	0.497	10.147	0.558	7.859	1.071	9.09	15.8	-
G10	7	50.0	14.62	10.12	0.360	9.040	0.626	7.712	1.204	7.22	21.4	-
G10	4	50.0	14.51	10.12	0.360	9.040	0.626	7.712	1.204	7.22	21.4	-
CB103	14	49.0	14.41	10.00	0.375	9.000	0.610	7.755	1.123	7.38	20.7	-
10WF, B10b	10	49.0	14.40	10.00	0.340	10.000	0.558	7.759	1.121	8.96	22.8	-
10WF, CB103	19	49.0	14.40	10.00	0.340	10.000	0.558	7.759	1.121	8.96	22.8	-
CB103A	16	49.0	14.40	10.00	0.350	10.000	0.558	7.859	1.071	8.96	22.5	-
CB103N	17	49.0	14.38	10.00	0.340	10.000	0.558	7.659	1.171	8.96	22.5	-
G10	8	45.0	13.25	10.09	0.330	9.010	0.565	7.804	1.143	7.97	23.6	-
10WF, B10a	10	45.0	13.24	10.12	0.350	8.022	0.618	7.759	1.181	6.49	22.2	-
10WF, CB102	19	45.0	13.24	10.12	0.350	8.022	0.618	7.759	1.181	6.49	22.2	-
CB102N	17	45.0	13.22	10.12	0.350	8.020	0.618	7.659	1.231	6.49	21.9	-
G10	7	44.5	13.14	10.00	0.320	9.000	0.566	7.712	1.144	7.95	24.1	-
G10	4	44.5	13.03	10.00	0.320	9.000	0.566	7.712	1.144	7.95	24.1	-
G10	2	44.0	12.95	10.00	0.310	9.000	0.567	7.680	1.160	7.94	24.8	-
G10	1	44.0	12.95	10.00	0.300	9.000	0.572	7.518	1.241	7.87	25.1	-
CB102	15	42.0	12.35	10.00	0.644	8.324	0.381	8.513	0.744	10.92	13.2	-
G10	8	42.0	12.34	10.00	0.320	9.000	0.520	7.804	1.098	8.65	24.4	-
G10	7	41.5	12.23	9.91	0.310	8.990	0.521	7.712	1.099	8.63	24.9	-
G10	4	41.5	12.12	9.91	0.310	8.990	0.521	7.712	1.099	8.63	24.9	-
CB102N	17	41.0	12.06	10.00	0.330	8.000	0.558	7.659	1.171	7.17	23.2	-
10WF, CB102	18	41.0	12.06	10.00	0.328	8.000	0.558	7.759	1.121	7.17	23.7	-
10WF, B10a	9	41.0	12.06	10.00	0.328	8.000	0.558	7.759	1.121	7.17	23.7	-
10WF, B10a	11	39.0	11.48	9.94	0.318	7.990	0.528	7.759	1.091	7.57	24.4	-
10WF, CB102	20	39.0	11.48	9.94	0.318	7.990	0.528	7.759	1.091	7.57	24.4	-
10WF, CB102	18	37.0	10.88	9.88	0.306	7.978	0.498	7.759	1.061	8.01	25.4	-
10WF, B10a	9	37.0	10.88	9.88	0.306	7.978	0.498	7.759	1.061	8.01	25.4	-
CB102N	17	37.0	10.85	9.88	0.305	7.975	0.498	7.659	1.111	8.01	25.1	-
CB102	15	36.0	10.58	10.00	0.467	8.147	0.381	8.513	0.744	10.69	18.2	-
CB102	17	33.0	9.72	9.75	0.295	7.965	0.433	7.659	1.046	9.20	26.0	-
10WF, CB102	19	33.0	9.71	9.75	0.292	7.964	0.433	7.759	0.996	9.20	26.6	-
10WF, B10a	10	33.0	9.71	9.75	0.292	7.964	0.433	7.759	0.996	9.20	26.6	-
CB102	15	31.0	9.11	10.00	0.320	8.000	0.381	8.513	0.744	10.50	26.6	-
CB101	15	30.0	8.82	10.23	0.298	6.068	0.495	8.513	0.858	6.13	28.6	-
10WF	22	29.1	8.55	9.88	0.425	5.935	0.389	8.470	0.702	7.63	19.9	-
B10	8	29.0	8.61	10.25	0.280	5.790	0.515	8.363	0.943	5.62	29.9	-
CB101N	17	29.0	8.54	10.24	0.279	5.789	0.510	8.495	0.873	5.68	30.4	-
10WF, CB101	19	29.0	8.53	10.22	0.289	5.799	0.500	8.455	0.883	5.80	29.3	-

Table 2.3.1 Dimensions and Primary Properties – Steel Sections 1887-1952

Designation	X ₁ ksi	X ₂ x 106 (1/ksi) ²	Elastic Properties						Plastic Modulus	
			Axis x-x			Axis y-y			Z _x in.3	Z _y in.3
			I _x in.4	S _x in.3	r _x in.	I _y in.4	S _y in.3	r _y in.		
12WF, B12	2323	5093	238.4	39.4	5.11	19.8	6.1	1.47	43.5	10.1
12WF, CB121	2256	5729	238.4	39.4	5.11	19.8	6.1	1.47	43.5	10.1
B12	2497	3878	232.3	38.5	5.08	17.3	5.5	1.38	43.1	8.9
12WF	2413	4219	228.0	38.0	5.12	17.1	5.3	1.40	41.6	9.8
B12	2411	4411	216.2	36.0	5.07	15.3	5.0	1.35	40.3	8.1
B12	2482	3899	216.6	36.1	5.07	14.2	4.7	1.30	40.2	7.7
B12	2346	4909	215.8	36.0	5.07	15.9	5.1	1.38	40.2	8.2
B12	2210	6232	213.6	35.6	5.08	16.4	5.0	1.41	39.2	8.2
12WF, B12	2117	7314	213.5	35.6	5.09	17.5	5.4	1.46	39.1	9.0
12WF, CB121	2044	8403	213.5	35.6	5.09	17.5	5.4	1.46	39.1	9.0
CB122	2034	8563	213.4	35.6	5.10	19.2	5.9	1.53	39.1	9.0
CB122N	2034	8563	213.4	35.6	5.10	19.2	5.9	1.53	39.1	9.0
B66	2276	6176	199.4	33.2	4.95	12.6	4.2	1.24	37.4	6.9
B66	2276	6176	199.4	33.2	4.95	12.6	4.2	1.24	37.4	6.9
B36	2760	2716	199.6	33.3	4.98	8.7	3.5	1.04	37.1	5.8
12WF, CB121	1982	9698	204.1	34.1	5.06	16.6	5.1	1.44	37.5	8.6
12WF, B12	2058	8335	204.1	34.1	5.06	16.6	5.1	1.44	37.5	8.6
B12	2010	9475	185.1	31.2	4.99	13.6	4.2	1.35	34.4	6.9
12WF, B12	1924	11333	183.4	30.9	4.98	14.5	4.5	1.40	34.0	7.7
12WF, CB121	1838	13621	183.4	30.9	4.98	14.5	4.5	1.40	34.0	7.7
B12	1998	9776	182.8	30.8	4.98	13.4	4.1	1.35	34.0	6.8
B12	2058	8715	181.4	30.6	4.96	12.6	4.0	1.31	33.8	6.6
CB122N	1824	14022	182.9	30.8	4.98	16.2	5.0	1.48	34.0	7.6
B25	2347	5731	175.5	29.2	4.89	7.3	2.9	1.00	32.7	4.9
CB121	1932	11190	183.0	30.7	4.99	13.8	4.6	1.37	33.9	7.0
CB103N	4364	364	382.5	73.7	4.44	129.3	25.6	2.58	82.0	38.8
10WF, CB103	4328	376	382.5	73.7	4.44	129.2	25.5	2.58	81.9	38.7
10WF, B10b	4328	376	382.5	73.7	4.44	129.2	25.5	2.58	81.9	38.7
CB103A	4834	310	308.8	61.8	4.05	106.3	20.4	2.38	70.6	31.8
CB103	5108	252	300.4	60.1	4.03	85.2	18.1	2.14	69.1	28.4
10WF, CB103	3959	529	343.7	67.1	4.41	116.5	23.1	2.57	74.0	35.0
10WF, B10b	3959	529	343.7	67.1	4.41	116.5	23.1	2.57	74.0	35.0
CB103N	3993	512	343.5	67.0	4.41	116.5	23.1	2.57	74.0	35.0
CB103A	4165	519	296.5	59.3	4.13	101.7	19.8	2.42	66.9	30.5
CB103	4221	482	283.2	56.6	4.15	79.5	17.3	2.20	63.9	26.6
CB103N	3620	746	305.6	60.4	4.39	104.0	20.7	2.56	66.2	31.4
10WF, CB103	3585	773	305.7	60.4	4.39	103.9	20.7	2.56	66.1	31.4
10WF, B10b	3585	773	305.7	60.4	4.39	103.9	20.7	2.56	66.1	31.4
CB103A	3634	814	284.3	56.9	4.23	97.3	19.2	2.48	63.3	29.3
G10	3895	571	277.5	54.8	4.36	66.4	14.7	2.13	60.7	23.6
G10	3909	563	275.5	54.4	4.36	66.4	14.7	2.14	60.7	23.6
CB103	3624	768	266.0	53.2	4.30	74.2	16.5	2.27	58.8	25.0
10WF, B10b	3265	1117	272.9	54.6	4.35	93.0	18.6	2.54	59.4	28.2
10WF, CB103	3265	1117	272.9	54.6	4.35	93.0	18.6	2.54	59.4	28.2
CB103A	3267	1123	272.0	54.4	4.35	93.0	18.6	2.54	59.6	28.2
CB103N	3300	1072	272.7	54.5	4.35	93.0	18.6	2.54	59.4	28.2
G10	3533	838	252.1	50.0	4.36	58.3	12.9	2.10	55.0	20.9
10WF, B10a	3631	773	248.6	49.1	4.33	53.2	13.3	2.00	54.0	20.2
10WF, CB102	3631	773	248.6	49.1	4.33	53.2	13.3	2.00	54.0	20.2
CB102N	3664	744	248.3	49.1	4.33	53.2	13.3	2.01	54.0	20.1
G10	3555	811	246.7	49.3	4.33	58.2	12.9	2.10	54.3	20.9
G10	3569	798	244.7	48.9	4.33	58.2	12.9	2.11	54.3	20.9
G10	3583	779	244.2	48.8	4.34	57.3	12.7	2.10	54.1	20.7
G10	3770	632	244.3	48.9	4.34	53.6	11.9	2.03	54.2	19.9
CB102	4051	739	190.4	38.1	3.93	36.8	8.9	1.73	44.2	14.2
G10	3324	1076	230.9	46.2	4.33	52.6	11.7	2.07	50.7	19.0
G10	3338	1046	225.8	45.6	4.30	52.6	11.7	2.07	50.0	19.0
G10	3352	1028	223.8	45.2	4.30	52.6	11.7	2.08	50.0	19.0
CB102N	3361	1051	222.3	44.5	4.29	47.7	11.9	1.99	48.7	18.1
10WF, CB102	3320	1104	222.4	44.5	4.29	47.7	11.9	1.99	48.6	18.1
10WF, B10a	3320	1104	222.4	44.5	4.29	47.7	11.9	1.99	48.6	18.1
10WF, B10a	3169	1332	209.7	42.2	4.27	44.9	11.2	1.98	46.0	17.1
10WF, CB102	3169	1332	209.7	42.2	4.27	44.9	11.2	1.98	46.0	17.1
10WF, CB102	3011	1631	196.9	39.9	4.25	42.2	10.6	1.97	43.3	16.1
10WF, B10a	3011	1631	196.9	39.9	4.25	42.2	10.6	1.97	43.3	16.1
CB102N	3051	1545	196.6	39.8	4.26	42.1	10.6	1.97	43.3	16.0
CB102	3021	2068	175.6	35.1	4.07	34.4	8.5	1.80	39.8	13.1
CB102	2766	2343	170.8	35.0	4.19	36.5	9.2	1.94	38.0	13.9
10WF, CB102	2714	2522	170.9	35.0	4.20	36.5	9.2	1.94	37.9	13.9
10WF, B10a	2714	2522	170.9	35.0	4.20	36.5	9.2	1.94	37.9	13.9
CB102	2403	4410	163.4	32.7	4.23	32.5	8.1	1.89	36.1	12.4
CB101	2877	2164	163.2	31.9	4.30	18.5	6.1	1.45	35.6	9.3
10WF	3398	1428	131.5	26.6	3.92	11.2	3.7	1.14	30.7	7.3
B10	3094	1592	160.7	31.4	4.32	14.9	5.2	1.32	35.0	8.2
CB101N	2909	2042	159.3	31.1	4.32	16.5	5.7	1.39	34.7	8.7
10WF, CB101	2900	2098	157.3	30.8	4.29	15.2	5.2	1.34	34.3	8.6

Table 2.3.1 Dimensions and Primary Properties -- Steel Sections 1887-1952

Designation	Source Reference Number	Wt. per ft lb	Area	Depth	Web Thickness	Flange Width	Average Flange Thickness	Distance	Distance	Compact Section Criteria		
			A	d	t _w	b _f	t _f	T	k	b _f /2t _f	h/t _w	F _y ^{''}
			in.2	in.	in.	in.	in.	in.	in.	in.		
10WF, B10	10	29.0	8.53	10.22	0.289	5.799	0.500	8.593	0.813	5.80	29.7	-
B10	6	28.5	8.41	10.19	0.285	5.785	0.495	8.345	0.922	5.85	29.3	-
B10	3	28.5	8.34	10.00	0.390	5.990	0.396	8.329	0.835	7.56	21.4	-
B10	1	27.5	8.05	10.00	0.340	5.940	0.415	8.193	0.903	7.16	24.1	-
B10	7	26.0	7.68	10.09	0.270	5.770	0.445	8.345	0.872	6.49	30.9	-
B10	8	26.0	7.65	10.12	0.260	5.770	0.450	8.363	0.878	6.41	32.2	62
CB101N	17	26.0	7.65	10.12	0.260	5.770	0.450	8.495	0.813	6.41	32.7	60
10WF, CB101	18	26.0	7.65	10.12	0.259	5.769	0.450	8.455	0.833	6.41	32.6	60
10WF, B10	9	26.0	7.65	10.12	0.259	5.769	0.450	8.593	0.763	6.41	33.2	58
CB101	15	26.0	7.64	10.10	0.259	6.029	0.430	8.513	0.793	7.01	32.9	60
B10	5	26.0	7.61	10.09	0.270	5.770	0.445	8.345	0.872	6.49	30.9	-
10WF, B10	11	25.0	7.35	10.08	0.252	5.762	0.430	8.593	0.743	6.70	34.1	55
10WF, CB101	20	25.0	7.35	10.08	0.252	5.762	0.430	8.455	0.813	6.70	33.6	57
----		25.0	7.35	9.90	0.350	5.860	0.375	9.025	0.438	7.81	25.8	-
B10	1	24.5	7.15	10.00	0.250	5.850	0.415	8.193	0.903	7.05	32.8	60
B10	7	23.5	6.96	10.00	0.250	5.750	0.400	8.345	0.827	7.20	33.4	58
B10	3	23.5	6.94	10.00	0.250	5.850	0.396	8.329	0.835	7.39	33.3	58
B10	5	23.5	6.89	10.00	0.250	5.750	0.400	8.345	0.827	7.20	33.4	58
10WF, B10	9	23.0	6.77	10.00	0.240	5.750	0.390	8.593	0.703	7.37	35.8	50
10WF, CB101	18	23.0	6.77	10.00	0.240	5.750	0.390	8.455	0.773	7.37	35.2	52
CB101	15	23.0	6.76	10.00	0.230	6.000	0.381	8.513	0.744	7.87	37.0	47
CB101N	17	23.0	6.76	10.00	0.240	5.750	0.390	8.495	0.753	7.37	35.4	51
B10	8	23.0	6.76	10.00	0.240	5.750	0.390	8.363	0.818	7.37	34.8	53
10WF	22	22.9	6.73	9.88	0.240	5.750	0.389	8.470	0.702	7.39	35.3	52
B10	1	22.5	6.65	10.00	0.200	5.800	0.415	8.193	0.903	6.99	41.0	38
B67	13	22.4	6.54	10.00	0.252	5.500	0.379	8.511	0.744	7.26	33.8	56
B67	13	22.25	6.54	10.00	0.252	5.500	0.379	8.511	0.744	7.26	33.8	56
B37	12	22.0	6.52	10.00	0.232	4.670	0.462	7.962	1.019	5.05	34.3	55
B26	21	22.0	6.42	10.00	0.250	5.000	0.400	8.357	0.821	6.25	33.4	58
B10	6	21.0	6.28	9.90	0.240	5.740	0.350	8.345	0.777	8.21	34.8	53
B10	8	21.0	6.24	9.91	0.240	5.750	0.345	8.363	0.773	8.33	34.8	53
10WF, B10	10	21.0	6.19	9.90	0.240	5.750	0.340	8.593	0.653	8.46	35.8	50
10WF, CB101	19	21.0	6.19	9.90	0.240	5.750	0.340	8.455	0.723	8.46	35.2	52
CB101N	17	21.0	6.18	9.90	0.240	5.750	0.340	8.495	0.703	8.46	35.4	51
----		21.0	6.18	9.90	0.240	5.740	0.375	8.425	0.738	7.65	35.1	52
CB101	15	21.0	6.17	9.90	0.230	6.000	0.332	8.513	0.695	9.04	37.0	47
CB93	9	48.0	14.11	9.24	0.398	9.082	0.591	6.935	1.154	7.68	17.4	-
G9	7	43.5	12.73	9.12	0.350	8.540	0.576	6.834	1.143	7.42	19.5	-
G9	5	43.5	12.62	9.12	0.350	8.540	0.576	6.834	1.143	7.42	19.5	-
CB93	9	43.0	12.65	9.12	0.357	9.041	0.531	6.935	1.094	8.51	19.4	-
G9	7	38.5	11.35	9.00	0.310	8.500	0.516	6.834	1.083	8.24	22.0	-
G9	5	38.5	11.23	9.00	0.310	8.500	0.516	6.834	1.083	8.24	22.0	-
G9	2	38.0	11.22	9.00	0.330	8.500	0.520	6.798	1.101	8.18	20.6	-
G9	1	38.0	11.18	9.00	0.290	8.500	0.522	6.648	1.176	8.14	22.9	-
CB93	9	38.0	11.17	9.00	0.316	9.000	0.470	6.935	1.033	9.57	21.9	-
G9	7	36.0	10.66	8.94	0.290	8.480	0.486	6.834	1.053	8.73	23.6	-
G9	5	36.0	10.55	8.94	0.290	8.480	0.486	6.834	1.053	8.73	23.6	-
CB92	9	35.0	10.29	9.19	0.335	6.556	0.566	6.935	1.129	5.79	20.7	-
CB92	9	32.0	9.40	9.10	0.307	6.528	0.518	6.935	1.081	6.30	22.6	-
CB92	9	29.0	8.53	9.00	0.279	6.500	0.470	6.935	1.033	6.91	24.9	-
B40	11	25.0	7.34	9.00	0.380	5.380	0.387	7.423	0.788	6.96	19.5	-
B9	3	24.0	7.04	9.00	0.365	5.555	0.362	7.415	0.792	7.67	20.3	-
B9	1	23.0	6.76	9.00	0.310	5.500	0.382	7.302	0.849	7.20	23.6	-
B40N	13	23.0	6.76	9.00	0.316	5.316	0.387	7.423	0.788	6.88	23.5	-
B9	8	23.0	6.75	9.12	0.260	5.250	0.410	7.453	0.833	6.40	28.7	-
B9	7	22.0	6.51	9.06	0.260	5.510	0.390	7.435	0.812	7.07	28.6	-
B9	6	22.0	6.45	9.06	0.260	5.510	0.390	7.435	0.812	7.07	28.6	-
B9	1	21.0	6.22	9.00	0.250	5.440	0.382	7.302	0.849	7.12	29.2	-
B40	10	21.0	6.17	9.00	0.250	5.250	0.387	7.423	0.788	6.79	29.7	-
B9	7	20.5	6.09	9.00	0.250	5.500	0.360	7.435	0.782	7.65	29.7	-
B9	6	20.5	6.02	9.00	0.250	5.500	0.360	7.435	0.782	7.65	29.7	-
B40	12	20.5	6.02	9.00	0.234	5.234	0.387	7.423	0.788	6.77	31.7	64
B9	4	20.5	6.01	9.00	0.250	5.440	0.362	7.415	0.792	7.51	29.7	-
B9	2	20.0	6.01	9.00	0.250	5.440	0.362	7.415	0.792	7.51	29.7	-
B40N	13	20.0	5.88	9.00	0.218	5.218	0.387	7.423	0.788	6.75	34.1	56
B9	8	20.0	5.86	9.00	0.235	5.500	0.348	7.453	0.773	7.91	31.7	64
B9	1	19.0	5.68	9.00	0.190	5.380	0.382	7.302	0.849	7.04	38.4	44
G8	4	37.0	10.77	8.12	0.330	8.030	0.526	5.954	1.083	7.64	18.0	-
G8	6	36.5	10.81	8.12	0.310	8.020	0.531	5.944	1.088	7.56	19.2	-
CB83		36.0	10.58	8.20	0.336	8.046	0.499	6.175	1.012	8.06	18.4	-
8WF, B8b	9	35.0	10.30	8.12	0.315	8.027	0.493	6.209	0.956	8.14	19.7	-
8WF, CB83	20	35.0	10.30	8.12	0.315	8.027	0.493	6.209	0.956	8.14	19.7	-
CB83N	19	35.0	10.28	8.18	0.315	8.025	0.491	6.175	1.004	8.17	19.6	-
CB83N	19	33.0	9.70	8.12	0.300	8.010	0.462	6.175	0.975	8.67	20.6	-
8WF, CB83	20	33.0	9.70	8.06	0.300	8.012	0.463	6.209	0.926	8.65	20.7	-

Table 2.3.1 Dimensions and Primary Properties -- Steel Sections 1887-1952

Designation	X ₁ ksi	X ₂ x 106 (1/ksi) ²	Elastic Properties						Plastic Modulus	
			Axis x-x			Axis y-y			Z _x in.3	Z _y in.3
			I _x in.4	S _x in.3	r _x in.	I _y in.4	S _y in.3	r _y in.		
10WF, B10	2961	1930	157.3	30.8	4.29	15.2	5.2	1.34	34.3	8.6
B10	3039	1751	154.1	30.2	4.28	14.2	4.9	1.30	33.7	7.9
B10	3130	1893	134.6	26.9	4.02	12.1	4.1	1.21	31.0	6.8
B10	3077	1880	134.6	26.9	4.09	11.7	3.9	1.20	30.7	6.7
B10	2797	2462	137.9	27.3	4.24	12.5	4.3	1.28	30.4	7.0
B10	2777	2475	139.5	27.6	4.27	12.7	4.4	1.29	30.6	7.1
CB101N	2611	3164	139.7	27.6	4.27	14.4	5.0	1.37	30.6	7.6
10WF, CB101	2620	3124	139.7	27.6	4.27	13.4	4.6	1.32	30.6	7.6
10WF, B10	2685	2831	139.7	27.6	4.27	13.4	4.6	1.32	30.6	7.6
CB101	2512	3685	139.5	27.6	4.27	15.7	5.2	1.43	30.6	8.0
B10	2805	2426	136.7	27.1	4.24	12.5	4.3	1.28	30.4	7.0
10WF, B10	2590	3285	133.2	26.4	4.26	12.7	4.4	1.31	29.3	7.3
10WF, CB101	2522	3653	133.2	26.4	4.26	12.7	4.4	1.31	29.3	7.3
----	2671	3543	117.0	23.6	3.99	9.8	3.4	1.16	28.3	6.7
B10	2765	2552	127.1	25.4	4.22	11.1	3.8	1.24	28.5	6.3
B10	2563	3503	123.2	24.6	4.21	10.9	3.8	1.25	27.3	6.2
B10	2573	3429	122.9	24.6	4.21	11.2	3.8	1.27	27.5	6.3
B10	2571	3446	121.9	24.4	4.21	10.9	3.8	1.26	27.3	6.2
10WF, B10	2402	4485	120.6	24.1	4.22	11.3	3.9	1.29	26.7	6.6
10WF, CB101	2328	5084	120.6	24.1	4.22	11.3	3.9	1.29	26.7	6.6
CB101	2237	5813	122.2	24.4	4.25	13.7	4.6	1.43	26.9	7.0
CB101N	2315	5185	120.5	24.1	4.22	12.4	4.3	1.35	26.7	6.6
B10	2484	3911	120.3	24.1	4.22	10.6	3.7	1.25	26.6	6.0
10WF	2579	3390	116.6	23.6	4.16	9.9	3.5	1.22	26.2	6.6
B10	2627	2885	122.8	24.6	4.27	10.8	3.7	1.27	27.2	6.2
B67	2469	4233	113.6	22.7	4.17	9.0	3.3	1.17	25.4	5.3
B67	2469	4233	113.6	22.7	4.17	9.0	3.3	1.17	25.4	5.3
B37	3009	1860	113.9	22.8	4.18	6.4	2.7	0.99	25.3	4.6
B26	2635	3302	110.3	22.1	4.15	6.9	2.8	1.03	24.5	4.6
B10	2346	5121	108.1	21.8	4.15	9.3	3.2	1.22	24.2	5.3
B10	2320	5350	107.5	21.7	4.15	9.2	3.2	1.21	24.1	5.3
10WF, B10	2219	6397	106.3	21.5	4.14	9.7	3.4	1.25	23.8	5.8
10WF, CB101	2134	7479	106.3	21.5	4.14	9.7	3.4	1.25	23.8	5.8
CB101N	2120	7655	106.3	21.5	4.15	10.8	3.8	1.32	23.8	5.8
----	2344	4993	107.5	21.7	4.17	9.3	3.2	1.22	25.5	6.3
CB101	2046	8653	107.6	21.7	4.18	12.0	4.0	1.39	24.0	6.1
CB93	3916	568	221.1	47.8	3.96	73.8	16.3	2.29	52.9	24.7
G9	4043	495	195.4	42.8	3.92	51.3	12.0	2.01	47.5	19.3
G9	4054	488	193.8	42.5	3.92	51.3	12.0	2.02	47.5	19.3
CB93	3531	846	195.5	42.9	3.93	65.4	14.5	2.28	47.0	22.0
G9	3662	723	171.9	38.2	3.89	44.4	10.4	1.98	42.0	16.9
G9	3672	712	170.3	37.9	3.89	44.4	10.4	1.99	42.0	16.9
G9	3769	636	170.9	38.0	3.90	44.1	10.4	1.98	42.6	16.9
G9	3916	550	169.8	37.7	3.90	40.7	9.6	1.91	42.0	16.1
CB93	3145	1322	170.4	37.9	3.91	57.1	12.7	2.26	41.2	19.2
G9	3474	886	160.5	35.9	3.88	41.0	9.7	1.96	39.3	15.7
G9	3495	866	158.9	35.5	3.88	41.0	9.7	1.97	39.3	15.7
CB92	3789	685	155.4	33.8	3.89	26.6	8.1	1.61	37.4	12.4
CB92	3487	943	140.5	30.9	3.87	24.0	7.4	1.60	34.0	11.2
CB92	3191	1335	126.0	28.0	3.84	21.5	6.6	1.59	30.6	10.1
B40	3371	1411	95.5	21.2	3.61	8.8	3.3	1.09	24.3	5.4
B9	3224	1668	92.1	20.5	3.62	8.8	3.2	1.12	23.6	5.3
B9	3132	1719	92.4	20.5	3.70	8.5	3.1	1.12	23.3	5.2
B40N	3043	1946	91.6	20.4	3.68	8.4	3.2	1.12	23.0	5.2
B9	2833	2314	99.2	21.8	3.83	10.1	3.7	1.22	23.2	5.3
B9	2817	2420	93.9	20.7	3.80	9.4	3.4	1.20	23.0	5.5
B9	2831	2373	92.9	20.5	3.80	9.4	3.4	1.21	23.0	5.5
B9	2896	2157	88.8	19.7	3.78	8.2	3.0	1.15	22.1	5.1
B40	2783	2537	87.6	19.5	3.77	8.1	3.1	1.14	21.7	5.0
B9	2660	3073	86.5	19.2	3.77	8.5	3.1	1.18	21.3	5.1
B9	2672	3010	85.5	19.0	3.77	8.5	3.1	1.19	21.3	5.1
B40	2739	2652	86.6	19.2	3.79	8.0	3.1	1.15	21.4	5.0
B9	2709	2869	85.1	18.9	3.76	8.2	3.0	1.17	21.3	5.0
B9	2709	2869	85.1	18.9	3.76	8.2	3.0	1.17	21.3	5.0
B40N	2688	2788	85.6	19.0	3.82	7.9	3.0	1.16	21.0	4.9
B9	2541	3609	84.1	18.7	3.79	8.3	3.0	1.19	20.6	4.9
B9	2708	2554	85.1	18.9	3.87	7.9	2.9	1.18	20.9	4.9
G8	4217	415	131.1	32.3	3.49	38.7	9.7	1.90	36.1	15.5
G8	4185	423	132.6	32.6	3.50	39.0	9.7	1.90	36.1	15.6
CB83	3715	697	131.3	32.0	3.52	43.4	10.8	2.02	35.3	16.4
8WF, B8b	3622	759	126.5	31.1	3.50	42.5	10.6	2.03	34.2	16.1
8WF, CB83	3622	759	126.5	31.1	3.50	42.5	10.6	2.03	34.2	16.1
CB83N	3616	764	128.2	31.3	3.53	42.3	10.5	2.03	34.4	16.0
CB83N	3420	950	119.8	29.5	3.51	39.6	9.9	2.02	32.2	15.0
8WF, CB83	3412	956	117.9	29.3	3.49	39.7	9.9	2.02	32.0	15.0

Table 2.3.1 Dimensions and Primary Properties -- Steel Sections 1887-1952

Designation	Source Reference Number	Wt. per ft lb	Area	Depth	Web Thickness	Flange Width	Average Flange Thickness	Distance	Distance	Compact Section Criteria		
			A	d	t _w	b _f	t _f	T	k	b _f /2t _f	h/t _w	F _y "
			in.2	in.	in.	in.	in.	in.	in.	in.		
8WF, B8b	8	33.0	9.70	8.06	0.300	8.012	0.463	6.209	0.926	8.65	20.7	-
G8	6	33.0	9.69	8.00	0.290	8.000	0.471	5.944	1.028	8.50	20.5	-
G8	4	33.0	9.57	8.00	0.300	8.000	0.466	5.954	1.023	8.59	19.8	-
G8	2	32.5	9.54	8.00	0.290	8.000	0.469	5.922	1.039	8.54	20.4	-
G8	1	32.5	9.52	8.00	0.280	8.000	0.472	5.780	1.110	8.48	20.6	-
8WF, CB83	20	31.0	9.12	8.00	0.288	8.000	0.433	6.209	0.896	9.24	21.6	-
8WF, B8b	9	31.0	9.12	8.00	0.288	8.000	0.433	6.209	0.896	9.24	21.6	-
CB83N	18	31.0	9.10	8.06	0.290	8.000	0.430	6.175	0.943	9.30	21.3	-
G8	4	31.0	9.01	7.94	0.290	7.990	0.436	5.954	0.993	9.17	20.5	-
8WF	24	30.8	9.06	7.88	0.420	6.675	0.454	6.006	0.935	7.35	14.3	-
CB82N	18	30.0	8.81	8.20	0.298	6.559	0.498	6.175	1.011	6.59	20.7	-
G8	6	29.5	8.69	7.88	0.285	7.995	0.411	5.944	0.968	9.74	20.9	-
8WF, B8a	10	28.0	8.23	8.06	0.285	6.540	0.463	6.209	0.926	7.06	21.8	-
8WF, CB82	23	28.0	8.23	8.06	0.285	6.540	0.463	6.209	0.926	7.06	21.8	-
----		28.0	8.23	8.00	0.390	6.650	0.375	6.125	0.938	8.87	15.7	-
8WF, CB82N	18	27.0	7.93	8.10	0.268	6.529	0.449	6.175	0.962	7.27	23.0	-
8WF, CB82	20	27.0	7.93	8.03	0.273	6.528	0.448	6.209	0.911	7.29	22.7	-
8WF, B8a	8	27.0	7.93	8.03	0.273	6.528	0.448	6.209	0.911	7.29	22.7	-
8WF	24	26.1	7.68	7.88	0.245	6.500	0.454	6.173	0.851	7.16	25.2	-
8WF, CB82	20	24.0	7.06	7.93	0.245	6.500	0.398	6.209	0.861	8.17	25.3	-
8WFB8a	9	24.0	7.06	7.93	0.245	6.500	0.398	6.209	0.861	8.17	25.3	-
CB82N	18	24.0	7.06	8.00	0.239	6.500	0.400	6.175	0.913	8.13	25.8	-
8WF	24	22.5	6.61	8.00	0.375	5.395	0.352	6.669	0.665	7.66	17.8	-
----		22.5	6.61	8.00	0.375	5.395	0.352	6.669	0.665	7.66	17.8	-
B8	1	21.25	6.25	8.00	0.360	5.370	0.337	6.421	0.790	7.98	17.8	-
B8	7	21.0	6.20	8.19	0.260	5.275	0.400	6.555	0.817	6.59	25.2	-
8WF, B8	8	21.0	6.18	8.19	0.252	5.272	0.403	6.757	0.716	6.54	26.8	-
8WF, CB81	21	21.0	6.18	8.19	0.252	5.272	0.403	6.619	0.786	6.54	26.3	-
B39	16	21.0	6.17	8.00	0.360	5.110	0.342	6.565	0.718	7.47	18.2	-
8WF, B8	10	20.0	5.88	8.14	0.248	5.268	0.378	6.757	0.691	6.97	27.2	-
8WF, CB81	23	20.0	5.88	8.14	0.248	5.268	0.378	6.619	0.761	6.97	26.7	-
B8	3	19.5	5.78	8.00	0.325	5.325	0.318	6.513	0.743	8.39	20.0	-
B8	6	19.0	5.68	8.06	0.270	5.270	0.344	6.537	0.761	7.66	24.2	-
B8	5	19.0	5.62	8.06	0.270	5.270	0.344	6.537	0.761	7.66	24.2	-
B8	7	19.0	5.60	8.09	0.250	5.265	0.350	6.555	0.767	7.52	26.2	-
8WF, B8	8	19.0	5.59	8.09	0.244	5.264	0.353	6.757	0.666	7.46	27.7	-
8WF, CB81	21	19.0	5.59	8.09	0.244	5.264	0.353	6.619	0.736	7.46	27.1	-
B39N	19	19.0	5.59	8.00	0.287	5.037	0.342	6.565	0.718	7.36	22.9	-
8WF	24	18.5	5.44	8.00	0.230	5.250	0.352	6.669	0.665	7.46	29.0	-
----		18.5	5.44	8.00	0.230	5.250	0.352	6.669	0.665	7.46	29.0	-
B8	1	18.0	5.37	8.00	0.250	5.260	0.337	6.421	0.790	7.82	25.7	-
B39	14	18.0	5.29	8.00	0.250	5.000	0.342	6.565	0.718	7.31	26.3	-
B8	6	17.5	5.20	8.00	0.250	5.250	0.314	6.537	0.731	8.36	26.1	-
B8	3	17.5	5.18	8.00	0.250	5.250	0.318	6.513	0.743	8.27	26.1	-
B38	11	17.5	5.15	8.00	0.210	4.330	0.412	6.157	0.921	5.26	29.3	-
B8	5	17.5	5.14	8.00	0.250	5.250	0.314	6.537	0.731	8.36	26.1	-
B39	17	17.5	5.14	8.00	0.231	4.981	0.342	6.565	0.718	7.28	28.4	-
B68	13	17.5	5.13	8.00	0.220	5.000	0.349	6.660	0.670	7.17	30.3	-
B68	12	17.5	5.12	8.00	0.220	5.000	0.349	6.660	0.670	7.17	30.3	-
B8	7	17.0	5.00	8.00	0.235	5.250	0.305	6.555	0.722	8.61	27.9	-
8WF, B8	9	17.0	5.00	8.00	0.230	5.250	0.308	6.757	0.621	8.52	29.4	-
8WF, CB81	22	17.0	5.00	8.00	0.230	5.250	0.308	6.619	0.691	8.52	28.8	-
B39	19	17.0	5.00	8.00	0.213	4.963	0.342	6.565	0.718	7.26	30.8	-
B8	1	16.25	4.81	8.00	0.180	5.190	0.337	6.421	0.790	7.71	35.7	51
8x5 1/4	25	23.0	6.77	8.00	0.460	5.470	0.305	6.555	0.722	8.98	14.3	-
8x5 1/4	25	21.0	6.18	8.00	0.380	5.400	0.305	6.555	0.722	8.87	17.3	-
8x5 1/4	25	19.0	5.59	8.00	0.310	5.320	0.305	6.555	0.722	8.74	21.1	-
8x5 1/4	25	17.0	5.00	8.00	0.240	5.250	0.305	6.555	0.722	8.62	27.3	-
8x6 1/4	26	27.0	7.94	8.00	0.355	6.610	0.398	6.254	0.873	8.30	17.6	-
8x6 1/4	26	24.0	7.06	8.00	0.245	6.500	0.398	6.254	0.873	8.17	25.5	-
----		32.6	9.59	8.00	0.313	7.938	0.438	6.200	0.900	9.07	19.8	-
B6	4	41.0	12.04	6.75	0.495	6.245	0.750	4.525	1.113	4.16	9.1	-
B6	4	30.0	8.81	6.38	0.350	6.100	0.565	4.525	0.928	5.40	12.9	-
6WF, B6	7	27.5	8.11	6.46	0.352	6.112	0.500	4.735	0.863	6.11	13.5	-
CBS6	10	27.5	8.09	6.46	0.352	6.112	0.500	4.835	0.813	6.11	13.7	-
6WF, B6	6	27.5	8.09	6.28	0.335	6.085	0.514	4.527	0.877	5.92	13.5	-
B6	4	27.0	7.92	6.25	0.335	6.085	0.500	4.525	0.863	6.09	13.5	-
6WF, B6	8	25.0	7.37	6.37	0.320	6.080	0.456	4.733	0.819	6.67	14.8	-
CBS6	11	25.0	7.35	6.37	0.320	6.080	0.456	4.833	0.769	6.67	15.1	-
CBS6	10	25.0	7.35	6.37	0.320	6.080	0.456	4.833	0.769	6.67	15.1	-
6WF, B6	6	25.0	7.35	6.19	0.300	6.050	0.471	4.523	0.834	6.42	15.1	-
B6	4	23.0	6.76	6.12	0.275	6.025	0.435	4.525	0.798	6.93	16.5	-
6WF, B6	7	22.5	6.63	6.28	0.290	6.050	0.411	4.733	0.774	7.36	16.3	-
6x6	12	22.5	6.62	6.00	0.375	6.063	0.377	4.521	0.740	8.04	12.1	-
CBS6	10	22.5	6.61	6.28	0.290	6.050	0.411	4.833	0.724	7.36	16.7	-

Table 2.3.1 Dimensions and Primary Properties -- Steel Sections 1887-1952

Designation	X ₁ ksi	X ₂ x 106 (1/ksi) ²	Elastic Properties						Plastic Modulus	
			Axis x-x			Axis y-y			Z _x in.3	Z _y in.3
			I _x in.4	S _x in.3	r _x in.	I _y in.4	S _y in.3	r _y in.		
8WF, B8b	3412	956	117.9	29.3	3.49	39.7	9.9	2.02	32.0	15.0
G8	3813	613	116.1	29.0	3.46	33.6	8.4	1.86	31.9	13.6
G8	3818	612	114.2	28.6	3.45	33.2	8.3	1.86	31.7	13.5
G8	3852	587	114.4	28.6	3.46	32.9	8.2	1.86	31.8	13.4
G8	4067	473	113.9	28.5	3.46	30.3	7.6	1.78	31.7	12.8
8WF, CB83	3226	1200	109.7	27.4	3.47	37.0	9.2	2.01	29.9	14.0
8WF, B8b	3226	1200	109.7	27.4	3.47	37.0	9.2	2.01	29.9	14.0
CB83N	3230	1200	110.9	27.5	3.49	36.7	9.2	2.01	30.0	13.9
G8	3651	739	106.2	26.7	3.43	30.5	7.6	1.84	29.7	12.5
8WF	4671	329	95.7	24.3	3.25	18.6	5.6	1.43	27.6	10.4
CB82N	3694	731	107.8	26.3	3.50	23.4	7.1	1.63	29.0	10.9
G8	3489	889	100.7	25.6	3.41	28.4	7.1	1.81	28.0	11.7
8WF, B8a	3451	956	97.8	24.3	3.45	21.6	6.6	1.62	26.6	10.0
8WF, CB82	3451	956	97.8	24.3	3.45	21.6	6.6	1.62	26.6	10.0
----	3475	1093	90.1	22.5	3.31	17.7	5.3	1.47	24.1	8.6
8WF, CB82N	3347	1069	95.9	23.7	3.48	20.8	6.4	1.62	25.9	9.7
8WF, CB82	3345	1080	94.1	23.4	3.44	20.8	6.4	1.62	25.6	9.7
8WF, B8a	3345	1080	94.1	23.4	3.44	20.8	6.4	1.62	25.6	9.7
8WF	3765	654	88.6	22.5	3.40	17.1	5.2	1.49	24.9	9.7
8WF, CB82	2997	1659	82.5	20.8	3.42	18.2	5.6	1.61	22.6	8.5
8WFB8a	2997	1659	82.5	20.8	3.42	18.2	5.6	1.61	22.6	8.5
CB82N	3007	1620	84.2	21.1	3.46	18.3	5.6	1.61	22.9	8.6
8WF	3709	946	68.3	17.1	3.23	7.5	2.8	1.08	19.5	5.4
----	3545	1134	68.3	17.1	3.23	7.5	2.8	1.08	19.5	5.4
B8	3576	1095	64.7	16.2	3.22	6.8	2.5	1.05	18.6	4.4
B8	3182	1455	73.5	17.9	3.44	8.6	3.3	1.18	20.0	5.3
8WF, B8	3068	1652	73.8	18.0	3.45	9.1	3.5	1.22	20.0	5.7
8WF, CB81	2984	1847	73.8	18.0	3.45	9.1	3.5	1.22	20.0	5.7
B39	3456	1267	63.4	15.9	3.21	6.6	2.6	1.03	18.2	4.3
8WF, B8	2935	1991	69.2	17.0	3.43	8.5	3.2	1.20	18.8	5.4
8WF, CB81	2845	2254	69.2	17.0	3.43	8.5	3.2	1.20	18.8	5.4
B8	3219	1649	60.6	15.1	3.24	6.7	2.5	1.08	17.4	4.2
B8	2973	2018	63.7	15.8	3.35	7.2	2.7	1.13	17.6	4.5
B8	2995	1968	62.9	15.6	3.35	7.2	2.7	1.13	17.6	4.5
B8	2906	2133	64.3	15.9	3.39	7.3	2.8	1.14	17.7	4.5
8WF, B8	2807	2412	64.7	16.0	3.40	7.9	3.0	1.19	17.7	5.0
8WF, CB81	2711	2770	64.7	16.0	3.40	7.9	3.0	1.19	17.7	5.0
B39N	3053	1895	60.3	15.1	3.29	6.3	2.5	1.06	17.0	4.1
8WF	2973	1888	62.1	15.5	3.38	6.9	2.6	1.13	17.2	4.9
----	2822	2328	62.1	15.5	3.38	6.9	2.6	1.13	17.2	4.9
B8	3013	1870	60.0	15.0	3.34	6.4	2.4	1.09	16.9	4.1
B39	2883	2252	58.7	14.7	3.33	6.1	2.4	1.07	16.4	4.0
B8	2765	2701	57.7	14.4	3.33	6.4	2.4	1.11	16.0	4.0
B8	2830	2473	57.4	14.3	3.33	6.4	2.4	1.11	16.2	4.0
B38	3384	1119	58.3	14.6	3.37	4.5	2.1	0.93	16.2	3.5
B8	2787	2626	56.9	14.2	3.33	6.4	2.4	1.11	16.0	4.0
B39	2805	2438	57.4	14.5	3.36	6.0	2.4	1.08	16.1	3.9
B68	2775	2497	58.4	14.6	3.38	6.2	2.5	1.10	16.2	4.0
B68	2772	2497	58.4	14.6	3.38	6.2	2.5	1.10	16.2	4.0
B8	2649	3142	56.0	14.0	3.35	6.2	2.4	1.11	15.5	3.9
8WF, B8	2559	3555	56.4	14.1	3.36	6.7	2.6	1.16	15.6	4.3
8WF, CB81	2452	4215	56.4	14.1	3.36	6.7	2.6	1.16	15.6	4.3
B39	2734	2629	57.2	14.3	3.38	6.0	2.4	1.09	15.8	3.9
B8	2748	2385	57.0	14.3	3.44	6.1	2.4	1.12	15.8	3.9
8x51/4	4063	759	65.4	16.4	3.10	7.1	2.6	1.02	19.1	4.5
8x51/4	3464	1321	62.3	15.6	3.18	6.8	2.5	1.05	17.8	4.3
8x51/4	3020	2080	59.2	14.8	3.26	6.5	2.4	1.08	16.7	4.0
8x51/4	2665	3065	56.0	14.0	3.35	6.2	2.4	1.11	15.6	3.9
8x61/4	3521	992	88.5	22.1	3.34	17.4	5.3	1.48	24.6	8.4
8x61/4	3112	1434	83.8	21.0	3.45	16.5	5.1	1.53	22.8	8.0
----	3307	1132	112.8	28.2	3.45	34.2	8.6	1.90	30.2	14.0
B6	7313	51	91.2	27.0	2.75	30.5	9.8	1.59	31.5	14.9
B6	5496	150	63.2	19.8	2.68	21.4	7.0	1.56	22.5	10.7
6WF, B6	4865	250	59.7	18.5	2.71	19.1	6.2	1.53	20.8	9.5
CBS6	4841	256	59.6	18.4	2.71	19.0	6.2	1.53	20.8	9.5
6WF, B6	5088	205	56.6	18.0	2.65	19.3	6.4	1.55	20.3	9.7
B6	4974	224	55.0	17.6	2.63	18.8	6.2	1.54	19.8	9.4
6WF, B6	4448	352	53.5	16.8	2.69	17.1	5.6	1.52	18.8	8.6
CBS6	4398	366	53.5	16.8	2.69	17.1	5.6	1.52	18.8	8.6
CBS6	4424	362	53.4	16.7	2.69	17.1	5.6	1.53	18.8	8.6
6WF, B6	4650	288	50.9	16.4	2.63	17.4	5.8	1.54	18.4	8.7
B6	4298	389	46.3	15.1	2.62	15.9	5.3	1.53	16.8	8.0
6WF, B6	4028	516	47.4	15.1	2.67	15.2	5.0	1.51	16.8	7.6
6x6	4405	402	41.0	13.7	2.49	12.2	4.0	1.36	15.4	7.1
CBS6	4005	533	47.3	15.0	2.67	15.2	5.0	1.52	16.8	7.6

Table 2.3.1 Dimensions and Primary Properties -- Steel Sections 1887-1952

Designation	Source Reference Number	Wt. per ft lb	Area	Depth	Web Thickness	Flange Width	Average Flange Thickness	Distance	Distance	Compact Section Criteria		
			A	d	t _w	b _f	t _f	T	k	b _f /2t _f	h/t _w	F _y "
			in.2	in.	in.	in.	in.	in.	in.	in.		
6WF, B6	6	22.5	6.61	6.10	0.270	6.020	0.425	4.525	0.788	7.08	16.8	-
----		22.5	6.62	6.00	0.375	6.063	0.375	5.125	0.438	8.08	13.7	-
BS6	1	20.5	6.06	6.19	0.300	6.060	0.359	4.785	0.701	8.44	16.0	-
6WF, B6	8	20.0	5.90	6.20	0.258	6.018	0.367	4.741	0.730	8.20	18.4	-
6WF, B6	5	20.0	5.89	6.00	0.250	6.000	0.375	4.525	0.738	8.00	18.1	-
CBS6	11	20.0	5.88	6.20	0.258	6.018	0.367	4.841	0.680	8.20	18.8	-
CBS6	10	20.0	5.88	6.20	0.258	6.018	0.367	4.841	0.680	8.20	18.8	-
6x6	12	20.0	5.88	6.00	0.250	5.938	0.378	4.519	0.741	7.85	18.1	-
BS6	2	18.0	5.33	6.09	0.270	6.030	0.314	4.781	0.656	9.60	17.7	-
6WF, B6	7	18.0	5.31	6.11	0.250	6.010	0.322	4.741	0.685	9.33	19.0	-
6WF, B6	6	18.0	5.30	5.91	0.245	5.995	0.328	4.529	0.691	9.14	18.5	-
CBS6	10	18.0	5.29	6.11	0.250	6.010	0.322	4.841	0.635	9.33	19.4	-
BS6	3	18.0	5.28	6.09	0.265	6.025	0.314	4.861	0.615	9.59	18.3	-
CBS6	9	18.0	5.28	6.09	0.265	6.025	0.314	4.837	0.627	9.59	18.3	-
6WF, B6	8	15.5	4.62	6.00	0.240	6.000	0.269	4.737	0.632	11.15	19.7	-
BS6	2	15.5	4.61	6.00	0.240	6.000	0.269	4.777	0.611	11.15	19.9	-
CBS6	11	15.5	4.59	6.00	0.240	6.000	0.269	4.837	0.582	11.15	20.2	-
CBS6	9	15.5	4.59	6.00	0.240	6.000	0.269	4.837	0.582	11.15	20.2	-
BS6	3	15.5	4.59	6.00	0.240	6.000	0.269	4.861	0.570	11.15	20.3	-
CBS6	10	15.5	4.59	6.00	0.240	6.000	0.269	4.837	0.582	11.15	20.2	-
6WF, B6	6	15.5	4.57	5.79	0.240	5.990	0.270	4.525	0.633	11.09	18.9	-
5X5	7	18.9	5.56	5.00	0.313	5.000	0.418	3.439	0.781	5.98	11.0	-
H2	6	18.9	5.54	5.00	0.313	5.000	0.417	3.415	0.793	6.00	10.9	-
BS5, H2	14	18.9	5.47	5.00	0.313	5.000	0.417	3.346	0.827	6.00	10.7	-
5WF, B5	3	18.5	5.45	5.12	0.265	5.025	0.420	3.555	0.783	5.98	13.4	-
CB51	5	18.5	5.45	5.12	0.265	5.025	0.420	3.555	0.783	5.98	13.4	-
5WF, B5	3	16.0	4.70	5.00	0.240	5.000	0.360	3.555	0.723	6.94	14.8	-
CB51	5	16.0	4.70	5.00	0.240	5.000	0.360	3.555	0.723	6.94	14.8	-
5WF, B5	2	13.5	3.98	4.86	0.230	4.990	0.292	3.551	0.655	8.54	15.4	-
4x4	7	13.8	3.99	4.00	0.313	4.000	0.361	2.553	0.724	5.54	8.2	-
H1	5	13.8	3.99	4.00	0.313	4.000	0.372	2.446	0.777	5.38	7.8	-
BS4	3	13.0	3.82	4.16	0.280	4.060	0.345	2.927	0.617	5.88	10.5	-
H1	6	13.0	3.82	4.00	0.250	3.937	0.372	2.505	0.748	5.29	10.0	-
4x4	8	13.0	3.82	4.00	0.253	3.940	0.371	2.533	0.734	5.31	10.0	-
BS4, CB41	24	10.0	2.93	4.00	0.220	4.000	0.265	2.927	0.537	7.55	13.3	-
BS4	1	7.5	2.22	3.87	0.170	3.950	0.200	2.927	0.472	9.88	17.2	-
12BL, B12L	3	22.0	6.47	12.31	0.260	4.030	0.424	10.835	0.737	4.75	41.7	37
CBL12	5	22.0	6.47	12.31	0.260	4.030	0.424	10.737	0.787	4.75	41.3	38
BJ12	2	21.0	6.22	12.16	0.250	4.135	0.401	10.569	0.795	5.16	42.3	36
12BL, B12L	3	19.0	5.62	12.16	0.240	4.010	0.349	10.835	0.662	5.74	45.1	32
CBL12	5	19.0	5.62	12.16	0.240	4.010	0.349	10.737	0.712	5.74	44.7	32
BJ12	1	18.5	5.44	12.00	0.240	4.125	0.321	10.569	0.715	6.43	44.0	33
12BL, B12L	3	16.5	4.86	12.00	0.230	4.000	0.269	10.835	0.582	7.43	47.1	29
CBL12	5	16.5	4.86	12.00	0.230	4.000	0.269	10.737	0.632	7.43	46.7	30
12BJ, BJ12	4	14.0	4.14	11.91	0.200	3.970	0.224	10.835	0.537	8.86	54.2	22
CBJ12	5	14.0	4.14	11.91	0.200	3.970	0.224	10.737	0.587	8.86	53.7	22
Jr12	6	11.8	3.45	12.00	0.175	3.060	0.226	10.928	0.536	6.78	62.4	17
Jr12	15	11.8	3.45	12.00	0.175	3.063	0.225	10.930	0.535	6.81	62.5	17
Jr11	6	10.3	3.01	11.00	0.165	2.844	0.215	9.979	0.511	6.61	60.5	18
10BL, B10L	3	19.0	5.61	10.25	0.250	4.020	0.394	8.835	0.707	5.10	35.3	52
CBL10	5	19.0	5.61	10.25	0.250	4.020	0.394	8.737	0.757	5.10	34.9	53
BJ10	2	19.0	5.60	10.16	0.250	4.010	0.399	8.579	0.790	5.03	34.3	55
10BL, B10L	3	17.0	4.98	10.12	0.240	4.010	0.329	8.835	0.642	6.09	36.8	48
CBL10	5	17.0	4.98	10.12	0.240	4.010	0.329	8.737	0.692	6.09	36.4	49
BJ10	2	16.5	4.86	10.00	0.240	4.000	0.319	8.579	0.710	6.28	35.7	50
10BL, B10L	3	15.0	4.40	10.00	0.230	4.000	0.269	8.835	0.582	7.43	38.4	44
CBL10	5	15.0	4.40	10.00	0.230	4.000	0.269	8.737	0.632	7.43	38.0	45
10BJ, BJ10	4	11.5	3.39	9.87	0.180	3.950	0.204	8.835	0.517	9.68	49.1	27
CBJ10	5	11.5	3.39	9.87	0.180	3.950	0.204	8.737	0.567	9.68	48.5	27
Jr10	15 6	9.0	2.64	10.00	0.155	2.688	0.208	9.024	0.488	6.48	58.2	19
Jr9	6	7.5	2.20	9.00	0.145	2.375	0.194	8.085	0.458	6.14	55.8	21
BJ8	2	16.0	4.74	8.12	0.240	3.875	0.376	6.591	0.764	5.16	27.5	-
8BL, B8L	3	15.0	4.43	8.12	0.245	4.015	0.314	6.865	0.627	6.39	28.0	-
CBL8	5	15.0	4.43	8.12	0.245	4.015	0.314	6.767	0.677	6.39	27.6	-
BJ8	1	14.5	4.28	8.00	0.240	3.875	0.316	6.591	0.704	6.14	27.5	-
8BL, B8L	3	13.0	3.83	8.00	0.230	4.000	0.254	6.865	0.567	7.87	29.8	-
CBL8	5	13.0	3.83	8.00	0.230	4.000	0.254	6.767	0.617	7.87	29.4	-
8BJ, BJ8	4	10.0	2.95	7.90	0.170	3.940	0.204	6.865	0.517	9.66	40.4	39
CBJ8	5	10.0	2.95	7.90	0.170	3.940	0.204	6.767	0.567	9.66	39.8	41
Jr8	15 6	6.5	1.92	8.00	0.135	2.281	0.189	7.126	0.437	6.03	52.8	23

Table 2.3.1 Dimensions and Primary Properties -- Steel Sections 1887-1952

Designation	X ₁ ksi	X ₂ x 106 (1/ksi) ²	Elastic Properties						Plastic Modulus	
			Axis x-x			Axis y-y			Z _x in.3	Z _y in.3
			I _x in.4	S _x in.3	r _x in.	I _y in.4	S _y in.3	r _y in.		
6WF, B6	4193	425	45.0	14.8	2.61	15.5	5.1	1.53	16.4	7.8
----	4168	501	41.0	13.7	2.49	12.2	4.0	1.36	15.4	7.1
BS6	3806	679	41.5	13.4	2.62	12.8	4.2	1.45	14.9	6.6
6WF, B6	3619	788	41.7	13.4	2.66	13.3	4.4	1.50	14.8	6.7
6WF, B6	3757	657	39.2	13.1	2.58	13.5	4.5	1.51	14.4	6.8
CBS6	3568	827	41.7	13.4	2.66	13.3	4.4	1.50	14.8	6.7
CBS6	3568	827	41.5	13.4	2.66	13.3	4.4	1.51	14.8	6.7
6x6	3833	623	38.8	12.9	2.57	11.4	3.8	1.39	14.3	6.7
BS6	3396	1067	35.8	11.7	2.59	11.0	3.6	1.43	13.0	5.6
6WF, B6	3282	1178	36.4	11.9	2.62	11.7	3.9	1.48	13.1	5.9
6WF, B6	3433	976	34.1	11.5	2.54	11.8	3.9	1.49	12.7	6.0
CBS6	3229	1248	36.2	11.9	2.62	11.6	3.9	1.48	13.1	5.9
BS6	3306	1165	35.5	11.7	2.59	11.0	3.6	1.44	12.9	5.6
CBS6	3252	1244	35.5	11.7	2.59	11.0	3.6	1.44	12.9	5.8
6WF, B6	2913	1954	30.3	10.1	2.56	9.7	3.2	1.45	11.0	4.9
BS6	2966	1810	30.3	10.1	2.56	9.2	3.1	1.41	11.0	4.8
CBS6	2854	2095	30.3	10.1	2.56	9.7	3.2	1.45	11.0	4.9
CBS6	2882	2054	30.1	10.0	2.56	9.2	3.1	1.42	11.0	4.9
BS6	2936	1908	30.1	10.0	2.56	9.2	3.1	1.42	11.0	4.8
CBS6	2882	2054	30.1	10.0	2.56	9.2	3.0	1.42	11.0	4.9
6WF, B6	3015	1677	28.1	9.7	2.48	9.7	3.2	1.46	10.6	4.9
5X5	5562	154	23.8	9.5	2.08	7.8	3.1	1.20	10.9	5.3
H2	5557	153	23.8	9.5	2.08	7.8	3.1	1.20	10.9	5.3
BS5, H2	5804	126	23.8	9.5	2.08	7.8	3.1	1.20	10.9	5.0
5WF, B5	5108	200	25.4	9.9	2.16	8.9	3.5	1.28	11.1	5.4
CB51	5108	200	25.4	9.9	2.16	8.9	3.5	1.28	11.1	5.4
5WF, B5	4462	338	21.3	8.5	2.13	7.5	3.0	1.26	9.5	4.6
CB51	4462	338	21.3	8.5	2.13	7.5	3.0	1.26	9.5	4.6
5WF, B5	3848	626	17.1	7.0	2.07	6.1	2.4	1.23	7.7	3.7
4x4	6475	87	10.7	5.3	1.64	3.6	1.8	0.95	6.1	3.0
H1	7069	61	10.7	5.3	1.64	3.6	1.8	0.95	6.2	2.9
BS4	5654	143	11.3	5.5	1.72	3.8	1.9	0.99	6.2	2.9
H1	6243	96	10.4	5.2	1.65	3.4	1.7	0.94	6.0	2.9
4x4	6458	90	9.9	5.0	1.64	3.3	1.7	0.95	6.0	2.9
BS4, CB41	4520	340	8.3	4.2	1.68	2.7	1.4	0.97	4.6	2.2
BS4	3488	937	6.1	3.1	1.65	2.0	1.0	0.94	3.4	1.6
12BL, B12L	2191	8207	155.7	25.3	4.91	4.6	2.3	0.84	28.8	3.6
CBL12	2174	8479	155.7	25.3	4.91	4.6	2.3	0.84	28.8	3.6
BJ12	2176	8337	147.0	24.2	4.86	4.3	2.1	0.83	27.6	3.4
12BL, B12L	1919	14527	130.1	21.4	4.81	3.7	1.8	0.81	24.4	3.0
CBL12	1899	15163	130.1	21.4	4.81	3.7	1.8	0.81	24.4	3.0
BJ12	1936	14423	121.5	20.2	4.73	3.3	1.6	0.78	23.2	2.7
12BL, B12L	1709	25498	105.3	17.5	4.65	2.8	1.4	0.76	20.2	2.3
CBL12	1685	26949	105.3	17.5	4.65	2.8	1.4	0.76	20.2	2.3
12BJ, BJ12	1482	45418	88.2	14.8	4.61	2.3	1.1	0.74	17.0	1.9
CBJ12	1456	48696	88.2	14.8	4.61	2.3	1.1	0.74	17.0	1.9
Jr12	1424	57133	72.2	12.0	4.57	1.0	0.6	0.53	14.0	1.1
Jr12	1421	57555	72.2	12.0	4.57	1.0	0.6	0.53	13.9	1.1
Jr11	1476	49388	53.1	9.6	4.20	0.8	0.5	0.50	11.2	0.9
10BL, B10L	2451	4910	96.2	18.8	4.14	4.2	2.1	0.86	21.2	3.3
CBL10	2428	5099	96.2	18.8	4.14	4.2	2.1	0.86	21.2	3.3
BJ10	2586	3958	94.5	18.6	4.11	3.9	2.0	0.83	21.1	3.2
10BL, B10L	2198	7943	81.8	16.2	4.05	3.5	1.7	0.83	18.3	2.8
CBL10	2172	8337	81.8	16.2	4.05	3.5	1.7	0.83	18.3	2.8
BJ10	2278	7003	77.4	15.5	3.99	3.0	1.5	0.79	17.6	2.5
10BL, B10L	1988	12632	68.8	13.8	3.95	2.8	1.4	0.80	15.6	2.3
CBL10	1958	13408	68.8	13.8	3.95	2.8	1.4	0.80	15.6	2.3
10BJ, BJ10	1585	31596	51.9	10.5	3.92	2.0	1.0	0.77	11.8	1.7
CBJ10	1551	34496	51.9	10.5	3.92	2.0	1.0	0.77	11.8	1.7
Jr10	1525	41612	39.0	7.8	3.85	0.6	0.5	0.48	9.0	0.8
Jr9	1595	35344	26.2	5.8	3.45	0.4	0.3	0.42	6.7	0.6
BJ8	3064	1881	52.4	12.9	3.32	3.3	1.7	0.84	14.5	2.8
8BL, B8L	2668	3474	48.0	11.8	3.29	3.3	1.7	0.86	13.3	2.6
CBL8	2632	3666	48.0	11.8	3.29	3.3	1.7	0.86	13.3	2.6
BJ8	2812	2825	44.9	11.2	3.24	2.7	1.4	0.80	12.6	2.3
8BL, B8L	2374	5815	39.5	9.9	3.21	2.6	1.3	0.83	11.1	2.1
CBL8	2334	6220	39.5	9.9	3.21	2.6	1.3	0.83	11.1	2.1
8BJ, BJ8	1860	14532	30.8	7.8	3.23	2.0	1.0	0.82	8.6	1.6
CBJ8	1815	16046	30.8	7.8	3.23	2.0	1.0	0.82	8.6	1.6
Jr8	1655	27795	18.7	4.7	3.12	0.3	0.3	0.42	5.3	0.5

Table 2.3.1 Dimensions and Primary Properties -- Steel Sections 1887-1952

Designation	Source Reference Number	Wt. per ft lb	Area	Depth	Web Thickness	Flange Width	Average Flange Thickness	Distance	Distance	Compact Section Criteria		
			A	d	t _w	b _f	t _f	T	k	b _f /2t _f	h/t _w	F _y "
			in.2	in.	in.	in.	in.	in.	in.	in.		ksi
B7	7	12.0	3.52	7.00	0.188	3.500	0.323	5.727	0.636	5.42	30.5	-
B42	8	12.0	3.52	7.00	0.188	3.500	0.333	5.607	0.697	5.26	29.8	-
Jr7	15 6	5.5	1.61	7.00	0.126	2.078	0.181	6.173	0.413	5.76	49.0	27
CBL6	5	16.0	4.72	6.25	0.260	4.030	0.404	4.817	0.717	4.99	18.5	-
B6L	11	16.0	4.72	6.25	0.260	4.030	0.404	4.899	0.676	4.99	18.8	-
BJ6	10	14.0	4.11	6.12	0.245	4.015	0.339	4.861	0.630	5.92	19.8	-
CBL6	5	12.0	3.53	6.00	0.230	4.000	0.279	4.817	0.592	7.17	20.9	-
B6L	11	12.0	3.53	6.00	0.230	4.000	0.279	4.899	0.551	7.17	21.3	-
BJ6	9	11.0	3.25	6.00	0.230	3.330	0.295	4.739	0.631	5.65	20.6	-
6B, B6b	13	10.0	2.91	6.00	0.188	3.000	0.310	4.753	0.623	4.84	25.3	-
B41	14	10.0	2.91	6.00	0.188	3.000	0.318	4.665	0.668	4.72	24.8	-
B108	6	9.4	2.77	6.00	0.188	2.938	0.290	4.797	0.602	5.07	25.5	-
BJ6	12	8.5	2.50	5.83	0.170	3.940	0.194	4.899	0.466	10.15	28.8	-
CBJ6	5	8.5	2.50	5.83	0.170	3.940	0.194	4.817	0.507	10.15	28.3	-
Jr6	15 6	4.4	1.30	6.00	0.114	1.844	0.173	5.218	0.391	5.34	45.8	31
H16	3	427.0	125.72	18.44	1.940	16.760	3.025	11.112	3.663	2.77	5.7	-
H16	3	413.0	121.48	18.25	1.880	16.700	2.931	11.112	3.569	2.85	5.9	-
H16	3	399.0	117.26	18.06	1.820	16.640	2.837	11.113	3.475	2.93	6.1	-
H16	3	384.0	113.07	17.88	1.760	16.580	2.744	11.111	3.382	3.02	6.3	-
H16	3	370.0	108.90	17.69	1.700	16.520	2.650	11.112	3.288	3.12	6.5	-
H16b	4	363.0	106.86	17.31	1.940	16.760	2.462	11.113	3.100	3.40	5.7	-
H16	3	356.0	104.75	17.50	1.640	16.460	2.556	11.112	3.194	3.22	6.8	-
H16	1 2	356.0	104.68	17.38	1.810	16.430	2.495	11.116	3.132	3.29	6.1	-
H16	3	342.0	100.63	17.31	1.580	16.400	2.462	11.113	3.100	3.33	7.0	-
H16	1 2	342.0	100.57	17.19	1.750	16.370	2.401	11.114	3.038	3.41	6.4	-
H16	3	328.0	96.53	17.13	1.520	16.340	2.369	11.111	3.007	3.45	7.3	-
H16	1 2	328.0	96.48	17.00	1.690	16.310	2.307	11.112	2.944	3.53	6.6	-
H16	3	314.0	92.45	16.94	1.460	16.280	2.275	11.112	2.913	3.58	7.6	-
H16	1 2	314.0	92.41	16.81	1.630	16.250	2.213	11.110	2.850	3.67	6.8	-
H16	3	301.0	88.56	16.75	1.410	16.230	2.181	11.112	2.819	3.72	7.9	-
H16	1 2	301.0	88.54	16.63	1.580	16.200	2.120	11.116	2.757	3.82	7.0	-
H16a	4	293.0	86.24	16.38	1.640	16.460	1.994	11.111	2.632	4.13	6.8	-
H16	3	288.0	84.69	16.56	1.360	16.180	2.087	11.113	2.725	3.88	8.2	-
H16	1 2	287.0	84.51	16.44	1.520	16.140	2.026	11.114	2.663	3.98	7.3	-
H16	3	274.0	80.67	16.38	1.300	16.120	1.994	11.111	2.632	4.04	8.5	-
H16	1 2	274.0	80.51	16.25	1.460	16.080	1.932	11.112	2.569	4.16	7.6	-
H16	3	265.0	78.00	16.25	1.260	16.080	1.931	11.112	2.569	4.16	8.8	-
H16	1 2	265.0	77.86	16.13	1.420	16.040	1.870	11.116	2.507	4.29	7.8	-
H16	3	256.0	75.35	16.13	1.220	16.040	1.869	11.111	2.507	4.29	9.1	-
H16	1 2	256.0	75.21	16.00	1.380	16.000	1.807	11.112	2.444	4.43	8.1	-
H16	3	247.0	72.70	16.00	1.180	16.000	1.806	11.112	2.444	4.43	9.4	-
H16	1 2	247.0	72.57	15.88	1.340	15.960	1.745	11.116	2.382	4.57	8.3	-
H16	3	238.0	70.07	15.88	1.140	15.960	1.744	11.111	2.382	4.58	9.7	-
H16	1 2	238.0	69.95	15.75	1.300	15.920	1.682	11.112	2.319	4.73	8.5	-
H16	3	230.0	67.60	15.75	1.110	15.930	1.681	11.112	2.319	4.74	10.0	-
H16	1 2	230.0	67.49	15.63	1.270	15.890	1.620	11.116	2.257	4.91	8.8	-
H16	3	221.0	65.14	15.63	1.080	15.900	1.619	11.111	2.257	4.91	10.3	-
H16	1 2	221.0	64.88	15.50	1.230	15.850	1.557	11.112	2.194	5.09	9.0	-
H16	3	212.0	62.53	15.50	1.040	15.860	1.556	11.112	2.194	5.10	10.7	-
H16	1 2	212.0	62.29	15.38	1.190	15.810	1.495	11.116	2.132	5.29	9.3	-
H16	3	203.0	59.94	15.38	1.000	15.820	1.494	11.111	2.132	5.30	11.1	-
H16	2	203.0	59.70	15.25	1.150	15.770	1.432	11.112	2.069	5.51	9.7	-
H16	3	195.0	57.35	15.25	0.960	15.780	1.431	11.112	2.069	5.51	11.6	-
H16	2	194.0	57.13	15.13	1.110	15.730	1.370	11.116	2.007	5.74	10.0	-
H16	3	186.0	54.77	15.13	0.920	15.740	1.369	11.111	2.007	5.75	12.1	-
H16	2	186.0	54.56	15.00	1.070	15.690	1.307	11.112	1.944	6.00	10.4	-
H16	3	177.0	52.20	15.00	0.880	15.700	1.306	11.112	1.944	6.01	12.6	-
H16	3	169.0	49.65	14.88	0.840	15.660	1.244	11.111	1.882	6.30	13.2	-
H16	3	160.0	47.10	14.75	0.800	15.620	1.181	11.112	1.819	6.61	13.9	-
H16	3	151.0	44.56	14.63	0.760	15.580	1.119	11.111	1.757	6.96	14.6	-
H16	3	143.0	42.03	14.50	0.720	15.540	1.056	11.112	1.694	7.36	15.4	-
H14d	7	426.0	125.34	18.69	1.880	16.700	3.033	11.299	3.696	2.75	6.0	-
CB146N	12	426.0	125.30	18.69	1.879	16.699	3.033	11.199	3.746	2.75	6.0	-
14WF	8 9 13 14 15	426.0	125.25	18.69	1.875	16.695	3.033	11.299	3.696	2.75	6.0	-
CB146	11	425.0	124.99	18.51	1.912	16.506	3.060	10.965	3.773	2.70	5.7	-
CB146N	12	412.0	121.16	18.50	1.827	16.647	2.938	11.199	3.651	2.83	6.1	-
14WF	7 8 13 15	412.0	121.15	18.50	1.825	16.645	2.938	11.299	3.601	2.83	6.2	-
CB146	11	405.0	119.20	18.25	1.829	16.423	2.928	10.965	3.641	2.80	6.0	-
H14d	7	398.0	117.08	18.31	1.775	16.595	2.843	11.299	3.506	2.92	6.4	-
CB146N	12	398.0	117.05	18.31	1.775	16.595	2.843	11.199	3.556	2.92	6.3	-
14WF	8 9 13 14 15	398.0	116.98	18.31	1.770	16.590	2.843	11.299	3.506	2.92	6.4	-
CB146	11	385.0	113.22	17.98	1.746	16.340	2.794	10.965	3.507	2.92	6.3	-
14WF	7 8 13 15	384.0	112.93	18.12	1.720	16.540	2.748	11.299	3.411	3.01	6.6	-
CB146N	12	384.0	112.92	18.12	1.721	16.541	2.748	11.199	3.461	3.01	6.5	-

Table 2.3.1 Dimensions and Primary Properties -- Steel Sections 1887-1952

Designation	X ₁ ksi	X ₂ x 106 (1/ksi) ²	Elastic Properties						Plastic Modulus	
			Axis x-x			Axis y-y			Z _x	Z _y
			I _x in.4	S _x in.3	r _x in.	I _y in.4	S _y in.3	r _y in.	in.3	in.3
B7	2952	2062	29.8	8.5	2.91	2.1	1.2	0.77	9.4	2.0
B42	3094	1703	29.8	8.5	2.91	2.1	1.2	0.77	9.6	1.9
Jr7	1773	20373	12.1	3.5	2.74	0.3	0.2	0.39	3.9	0.4
CBL6	4057	564	31.7	10.1	2.59	4.3	2.1	0.96	11.4	3.4
B6L	4093	545	31.7	10.1	2.59	4.3	2.1	0.96	11.4	3.4
BJ6	3593	931	26.4	8.6	2.54	3.6	1.8	0.93	9.7	2.8
CBL6	3110	1704	21.7	7.2	2.48	2.9	1.4	0.90	8.1	2.3
B6L	3156	1607	21.7	7.2	2.48	2.9	1.4	0.90	8.1	2.3
BJ6	3502	1133	19.3	6.4	2.44	1.6	1.0	0.71	7.3	1.6
6B, B6b	3441	1151	17.8	5.9	2.47	1.3	0.9	0.66	6.7	1.4
B41	3545	1019	17.8	5.9	2.47	1.3	0.9	0.66	6.8	1.4
B108	3177	1603	16.7	5.6	2.46	1.2	0.8	0.64	6.2	1.2
BJ6	2324	5425	14.8	5.1	2.43	1.9	1.0	0.87	5.6	1.5
CBJ6	2269	5968	14.8	5.1	2.43	1.9	1.0	0.87	5.6	1.5
Jr6	1976	13393	7.3	2.4	2.37	0.2	0.2	0.36	2.8	0.3
H16	11873	8	6416.2	696.0	7.14	2355.9	281.1	4.33	855.8	433.8
H16	11543	9	6121.5	670.8	7.10	2257.2	270.3	4.31	821.9	417.0
H16	11209	10	5834.0	646.0	7.05	2160.3	259.6	4.29	788.6	400.3
H16	10876	11	5553.6	621.4	7.01	2065.1	249.1	4.27	755.8	384.0
H16	10539	12	5280.2	597.1	6.96	1971.7	238.7	4.26	723.5	367.8
H16b	10449	13	4909.6	567.2	6.78	1914.5	228.5	4.23	687.2	354.7
H16	10198	14	5013.7	573.0	6.92	1880.0	228.4	4.24	691.6	351.9
H16	10319	14	4877.0	561.4	6.83	1827.0	222.3	4.18	679.5	344.2
H16	9854	16	4754.0	549.2	6.87	1790.1	218.3	4.22	660.2	336.1
H16	9975	16	4622.0	537.8	6.78	1737.0	212.3	4.16	648.4	328.6
H16	9509	18	4500.9	525.7	6.83	1701.8	208.3	4.20	629.4	320.6
H16	9625	18	4373.0	514.5	6.73	1650.0	202.3	4.14	617.6	313.1
H16	9162	21	4254.5	502.4	6.78	1615.2	198.4	4.18	599.1	305.4
H16	9274	21	4131.0	491.4	6.69	1564.0	192.5	4.11	587.4	297.8
H16	8826	24	4018.4	479.8	6.74	1533.2	188.9	4.16	569.8	290.7
H16	8942	24	3899.0	469.0	6.64	1483.0	183.1	4.09	558.9	283.2
H16a	9674	22	3685.1	405.1	6.54	1462.0	177.6	4.12	534.8	275.7
H16	8485	28	3788.4	457.5	6.69	1452.5	179.5	4.14	541.0	276.2
H16	8587	28	3669.0	446.4	6.59	1400.0	173.5	4.07	529.6	268.4
H16	8131	33	3560.7	434.9	6.64	1370.6	170.0	4.12	512.0	261.5
H16	8230	33	3445.0	424.0	6.54	1319.0	164.1	4.05	500.8	253.8
H16	7892	37	3412.4	420.0	6.61	1316.8	163.8	4.11	492.9	251.9
H16	7989	37	3300.0	409.3	6.51	1266.0	157.9	4.03	482.1	244.1
H16	7653	42	3266.7	405.2	6.58	1263.8	157.6	4.10	474.1	242.2
H16	7749	42	3157.0	394.6	6.48	1214.0	151.7	4.02	463.2	234.6
H16	7411	47	3123.7	390.5	6.55	1211.4	151.4	4.08	455.4	232.8
H16	7508	47	3016.0	380.0	6.45	1162.0	145.6	4.00	445.0	225.1
H16	7170	54	2983.4	375.9	6.53	1159.8	145.3	4.07	436.9	223.4
H16	7266	53	2879.0	365.5	6.41	1111.0	139.6	3.99	426.5	215.8
H16	6942	61	2848.9	361.8	6.49	1111.0	139.5	4.05	419.3	214.4
H16	7040	60	2747.0	351.6	6.38	1063.0	133.8	3.97	409.3	206.8
H16	6713	69	2716.9	347.8	6.46	1062.7	133.7	4.04	401.9	205.5
H16	6796	69	2614.0	337.3	6.35	1013.0	127.8	3.95	391.2	197.7
H16	6470	80	2584.1	333.4	6.43	1013.0	127.7	4.02	384.0	196.3
H16	6553	80	2484.0	323.1	6.31	964.0	122.0	3.93	373.7	188.5
H16	6224	93	2453.9	319.2	6.40	963.9	121.9	4.01	366.3	187.3
H16	6307	92	2356.0	309.0	6.28	916.0	116.1	3.92	356.1	179.6
H16	5977	108	2326.1	305.1	6.37	915.5	116.0	4.00	348.9	178.3
H16	6061	108	2231.0	295.0	6.25	868.0	110.4	3.90	339.0	170.6
H16	5731	127	2200.9	291.0	6.34	867.7	110.3	3.98	331.6	169.4
H16	5814	127	2108.0	281.1	6.22	821.0	104.6	3.88	321.8	161.8
H16	5481	151	2078.0	277.1	6.31	820.7	104.5	3.96	314.5	160.6
H16	5233	181	1957.6	263.2	6.28	774.2	98.9	3.95	297.6	151.9
H16	4984	218	1839.5	249.4	6.25	728.5	93.3	3.93	281.0	143.3
H16	4734	266	1723.8	235.7	6.22	683.4	87.7	3.92	264.5	134.8
H16	4482	328	1610.4	222.1	6.19	638.9	82.2	3.90	248.2	126.4
H14d	11518	9	6613.0	707.6	7.26	2361.7	282.8	4.34	867.9	434.1
CB146N	11537	9	6611.4	707.5	7.26	2361.2	282.8	4.34	867.9	434.0
14WF	11510	9	6610.3	707.4	7.26	2359.5	282.7	4.34	867.5	433.8
CB146	11852	8	6420.5	693.7	7.17	2301.0	278.8	4.29	853.7	428.2
CB146N	11223	10	6309.7	682.1	7.22	2265.7	272.2	4.32	833.9	417.6
14WF	11199	10	6309.7	682.1	7.22	2264.9	272.1	4.32	833.7	417.5
CB146	11397	9	6010.5	658.8	7.10	2168.2	264.0	4.27	806.8	405.2
H14d	10883	11	6016.3	657.2	7.17	2171.7	261.7	4.31	800.4	401.4
CB146N	10905	11	6015.2	657.0	7.17	2171.7	261.7	4.31	800.4	401.4
14WF	10876	11	6013.7	656.9	7.17	2169.7	261.6	4.31	800.0	401.1
CB146	10923	11	5609.4	624.0	7.04	2037.4	249.4	4.24	760.2	382.4
14WF	10559	12	5727.3	632.2	7.12	2078.1	251.3	4.29	767.2	385.2
CB146N	10582	12	5726.9	632.1	7.12	2078.4	251.3	4.29	767.3	385.3

Table 2.3.1 Dimensions and Primary Properties -- Steel Sections 1887-1952

Designation	Source Reference Number	Wt. per ft lb	Area	Depth	Web Thickness	Flange Width	Average Flange Thickness	Distance	Distance	Compact Section Criteria		
			A	d	t _w	b _f	t _f	T	k	b _f /2t _f	h/t _w	F _y "
			in.2	in.	in.	in.	in.	in.	in.	in.		
H14d	7	370.0	108.87	17.94	1.660	16.480	2.658	11.299	3.321	3.10	6.8	-
CB146N	12	370.0	108.83	17.94	1.659	16.479	2.658	11.199	3.371	3.10	6.8	-
14WF	8 9 13 14 15	370.0	108.78	17.94	1.655	16.475	2.658	11.299	3.321	3.10	6.8	-
CB146	11	365.0	107.34	17.71	1.661	16.255	2.660	10.965	3.373	3.06	6.6	-
CB146N	12	356.0	104.68	17.75	1.602	16.422	2.563	11.199	3.276	3.20	7.0	-
14WF	7 8 13 15	356.0	104.68	17.75	1.600	16.420	2.563	11.299	3.226	3.20	7.1	-
CB146	11	345.0	101.47	17.44	1.578	16.172	2.524	10.965	3.237	3.20	6.9	-
14WF	7 8 9 13 14 15	342.0	100.59	17.56	1.545	16.365	2.468	11.299	3.131	3.32	7.3	-
CB146N	12	342.0	100.56	17.56	1.545	16.365	2.468	11.199	3.181	3.32	7.2	-
H14d	7	328.0	96.52	17.38	1.480	16.300	2.378	11.299	3.041	3.43	7.6	-
CB146N	12	328.0	96.47	17.38	1.479	16.299	2.378	11.199	3.091	3.43	7.6	-
14WF	8 13 15	328.0	96.43	17.38	1.475	16.295	2.378	11.299	3.041	3.43	7.7	-
CB146	11	325.0	95.58	17.16	1.493	16.087	2.387	10.965	3.100	3.37	7.3	-
14WF	7 8 9 13 14 15	320.0	94.12	16.81	1.890	16.710	2.093	11.299	2.756	3.99	6.0	-
CB146N	12	320.0	94.09	16.81	1.890	16.710	2.093	11.199	2.806	3.99	5.9	-
H14d	7	314.0	92.39	17.19	1.420	16.240	2.283	11.299	2.946	3.56	8.0	-
CB146N	12	314.0	92.36	17.19	1.420	16.240	2.283	11.199	2.996	3.56	7.9	-
14WF	8 9 13 14 15	314.0	92.30	17.19	1.415	16.235	2.283	11.299	2.946	3.56	8.0	-
CB146	10	305.0	89.70	16.89	1.406	16.000	2.250	10.965	2.963	3.56	7.8	-
H14d	7	300.0	88.28	17.00	1.360	16.180	2.188	11.299	2.851	3.70	8.3	-
CB146N	12	300.0	88.24	17.00	1.359	16.179	2.188	11.199	2.901	3.70	8.2	-
14WF	8 13 15	300.0	88.20	17.00	1.355	16.175	2.188	11.299	2.851	3.70	8.3	-
H14	5	298.0	87.63	16.88	1.390	15.610	2.246	11.113	2.881	3.48	8.0	-
CB146	10	295.0	86.76	16.75	1.362	15.956	2.181	10.965	2.894	3.66	8.1	-
H14b	1	291.2	85.63	16.88	1.410	15.160	2.249	11.118	2.881	3.37	7.9	-
H14	5	289.0	85.01	16.75	1.350	15.570	2.184	11.112	2.819	3.57	8.2	-
H14	4	288.5	84.50	16.88	1.410	14.900	2.250	11.118	2.881	3.31	7.9	-
H14	2	287.5	84.50	16.88	1.410	14.900	2.250	11.118	2.881	3.31	7.9	-
CB146N	12	287.0	84.39	16.81	1.313	16.133	2.093	11.199	2.806	3.85	8.5	-
14WF	7 8 9 13 14 15	287.0	84.37	16.81	1.310	16.130	2.093	11.299	2.756	3.85	8.6	-
CB146	10	285.0	83.82	16.61	1.318	15.912	2.112	10.965	2.825	3.77	8.3	-
H14b	1	282.4	83.07	16.75	1.370	15.120	2.186	11.112	2.819	3.46	8.1	-
H14	5	280.0	82.39	16.63	1.310	15.530	2.121	11.113	2.756	3.66	8.5	-
H14	4	279.5	81.97	16.75	1.370	14.860	2.188	11.112	2.819	3.40	8.1	-
H14	2	278.5	81.97	16.75	1.370	14.860	2.188	11.112	2.819	3.40	8.1	-
CB146	10	275.0	80.87	16.47	1.276	15.870	2.041	10.965	2.754	3.89	8.6	-
H14b	1	273.7	80.51	16.63	1.330	15.080	2.124	11.118	2.756	3.55	8.4	-
14WF	7	273.0	80.30	16.62	1.250	16.070	1.998	11.299	2.661	4.02	9.0	-
CB146N	12	273.0	80.28	16.62	1.250	16.070	1.998	11.199	2.711	4.02	9.0	-
14WF	8 13 15	273.0	80.22	16.62	1.245	16.065	1.998	11.299	2.661	4.02	9.1	-
H14	5	271.0	79.79	16.50	1.270	15.490	2.059	11.112	2.694	3.76	8.7	-
H14	4	271.0	79.44	16.63	1.330	14.820	2.125	11.118	2.756	3.49	8.4	-
H14	2	270.0	79.44	16.63	1.330	14.820	2.125	11.118	2.756	3.49	8.4	-
H14	1	265.1	77.97	16.50	1.290	15.040	2.061	11.112	2.694	3.65	8.6	-
CB146	10	265.0	77.93	16.33	1.232	15.826	1.971	10.965	2.684	4.01	8.9	-
14WF	7 8 9 13 14 15	264.0	77.63	16.50	1.205	16.025	1.938	11.299	2.601	4.13	9.4	-
CB146N	12	264.0	77.62	16.50	1.206	16.026	1.938	11.199	2.651	4.13	9.3	-
H14	4	262.5	76.93	16.50	1.290	14.780	2.063	11.112	2.694	3.58	8.6	-
H14	5	262.0	77.20	16.38	1.230	15.450	1.996	11.113	2.631	3.87	9.0	-
H14	2	261.5	76.93	16.50	1.290	14.780	2.063	11.112	2.694	3.58	8.6	-
H14b	1	256.5	75.43	16.38	1.250	15.000	1.999	11.118	2.631	3.75	8.9	-
CB146	10	255.0	74.99	16.19	1.187	15.781	1.901	10.965	2.614	4.15	9.2	-
CB146N	12	255.0	74.98	16.37	1.172	15.992	1.873	11.199	2.586	4.27	9.6	-
14WF	7 8 13 15	255.0	74.98	16.37	1.170	15.990	1.873	11.299	2.536	4.27	9.7	-
H14	5	254.0	74.62	16.25	1.190	15.410	1.934	11.112	2.569	3.99	9.3	-
H14	4	254.0	74.43	16.38	1.250	14.740	2.000	11.118	2.631	3.69	8.9	-
H14	2	253.0	74.43	16.38	1.250	14.740	2.000	11.118	2.631	3.69	8.9	-
H14b	1	247.9	72.91	16.25	1.210	14.960	1.936	11.112	2.569	3.86	9.2	-
CB146N	12	246.0	72.33	16.25	1.127	15.947	1.813	11.199	2.526	4.40	9.9	-
14WF	7 8 9 13 14 15	246.0	72.33	16.25	1.125	15.945	1.813	11.299	2.476	4.40	10.0	-
H14	4	245.5	71.94	16.25	1.210	14.700	1.938	11.112	2.569	3.79	9.2	-
CB146	10	245.0	72.06	16.05	1.144	15.738	1.830	10.965	2.543	4.30	9.6	-
H14	5	245.0	72.05	16.13	1.150	15.370	1.871	11.113	2.506	4.11	9.7	-
H14	2	244.5	71.94	16.25	1.210	14.700	1.938	11.112	2.569	3.79	9.2	-
H14b	1	239.3	70.39	16.13	1.170	14.920	1.874	11.118	2.506	3.98	9.5	-
14WF	7 8 9 13 14 15	237.0	69.69	16.12	1.090	15.910	1.748	11.299	2.411	4.55	10.4	-
CB146N	12	237.0	69.68	16.12	1.091	15.911	1.748	11.199	2.461	4.55	10.3	-
H14	4	237.0	69.45	16.13	1.170	14.660	1.875	11.118	2.506	3.91	9.5	-
H14	5	236.0	69.49	16.00	1.110	15.330	1.809	11.112	2.444	4.24	10.0	-
H14	2	236.0	69.45	16.13	1.170	14.660	1.875	11.118	2.506	3.91	9.5	-
CB146	10	235.0	69.11	15.91	1.099	15.693	1.759	10.965	2.472	4.46	10.0	-
H14b	1	230.8	67.89	16.00	1.130	14.880	1.811	11.112	2.444	4.11	9.8	-
H14	4	228.5	66.98	16.00	1.130	14.620	1.813	11.112	2.444	4.03	9.8	-
14WF	7 8 9 13 14	228.0	67.06	16.00	1.045	15.865	1.688	11.299	2.351	4.70	10.8	-
CB146N	12	228.0	67.03	16.00	1.045	15.865	1.688	11.199	2.401	4.70	10.7	-

Table 2.3.1 Dimensions and Primary Properties – Steel Sections 1887-1952

Designation	X ₁ ksi	X ₂ x 106 (1/ksi) ²	Elastic Properties						Plastic Modulus	
			Axis x-x			Axis y-y			Z _x in.3	Z _y in.3
			I _x	S _x	r _x	I _y	S _y	r _y		
			in.4	in.3	in.	in.4	in.3	in.		
H14d	10239	14	5456.6	608.3	7.08	1987.9	241.2	4.27	735.5	369.6
CB146N	10256	14	5455.1	608.2	7.08	1987.5	241.2	4.27	735.5	369.6
14WF	10230	14	5454.2	608.1	7.08	1986.0	241.1	4.27	735.1	369.4
CB146	10443	13	5221.4	589.7	6.97	1909.1	234.9	4.22	714.5	360.0
CB146N	9924	16	5179.3	583.6	7.03	1896.4	231.0	4.26	703.0	353.7
14WF	9902	16	5179.4	583.6	7.03	1895.7	230.9	4.26	702.9	353.6
CB146	9958	15	4843.4	555.5	6.91	1783.5	220.6	4.19	669.3	337.8
14WF	9569	18	4911.5	559.4	6.99	1806.9	220.8	4.24	671.1	338.0
CB146N	9589	18	4910.4	559.3	6.99	1806.9	220.8	4.24	671.1	338.0
H14d	9235	21	4658.3	536.0	6.95	1720.1	211.1	4.22	640.5	322.8
CB146N	9252	20	4656.8	535.9	6.95	1719.7	211.0	4.22	640.4	322.8
14WF	9227	21	4656.1	535.8	6.95	1718.5	210.9	4.22	640.1	322.6
CB146	9460	19	4475.9	521.6	6.84	1659.9	206.4	4.17	624.7	315.8
14WF	9221	22	4141.7	492.8	6.63	1635.1	195.7	4.17	590.0	303.5
CB146N	9247	22	4140.7	492.6	6.63	1635.0	195.7	4.17	590.0	303.5
H14d	8890	24	4401.5	512.1	6.90	1633.0	201.1	4.20	609.3	307.4
CB146N	8909	24	4400.5	512.0	6.90	1632.9	201.1	4.20	609.3	307.4
14WF	8882	24	4399.4	511.9	6.90	1631.4	201.0	4.20	608.9	307.2
CB146	8956	23	4121.5	488.0	6.78	1539.1	192.4	4.14	581.0	294.1
H14d	8543	28	4151.5	488.4	6.86	1547.5	191.3	4.19	578.6	292.2
CB146N	8562	27	4150.1	488.2	6.86	1547.2	191.3	4.19	578.5	292.2
14WF	8536	28	4149.5	488.2	6.86	1546.0	191.2	4.19	578.2	292.0
H14	9009	23	4011.3	475.4	6.77	1406.5	180.2	4.01	566.2	277.2
CB146	8697	26	3948.1	471.4	6.75	1479.4	185.4	4.13	559.3	283.4
H14b	9078	22	3897.7	462.0	6.75	1290.7	170.3	3.88	552.8	262.4
H14	8775	25	3857.7	460.6	6.74	1356.1	174.2	3.99	546.9	267.9
H14	9098	22	3836.1	454.7	6.74	1226.7	164.7	3.81	544.5	253.9
H14	9098	22	3836.1	454.7	6.74	1226.7	164.7	3.81	544.5	253.9
CB146N	8230	32	3912.3	465.5	6.81	1467.3	181.9	4.17	549.3	277.8
14WF	8207	32	3912.1	465.5	6.81	1466.5	181.8	4.17	549.0	277.7
CB146	8439	29	3778.1	454.8	6.71	1420.7	178.6	4.12	537.9	272.8
H14b	8846	24	3748.1	447.5	6.72	1244.3	164.6	3.87	533.8	253.5
H14	8539	28	3706.9	445.9	6.71	1306.4	168.2	3.98	527.9	258.7
H14	8863	24	3688.8	440.5	6.71	1182.4	159.1	3.80	525.8	245.3
H14	8863	24	3688.8	440.5	6.71	1182.4	159.1	3.80	525.8	245.3
CB146	8176	33	3607.8	438.1	6.68	1362.0	171.6	4.10	516.4	262.1
H14b	8609	27	3601.2	433.2	6.69	1198.5	158.9	3.86	515.5	244.8
14WF	7855	38	3675.1	442.3	6.76	1384.2	172.3	4.15	519.3	262.9
CB146N	7875	38	3674.1	442.1	6.77	1384.2	172.3	4.15	519.3	262.9
14WF	7849	38	3673.2	442.0	6.77	1382.9	172.2	4.15	518.9	262.7
H14	8302	31	3558.8	431.4	6.68	1257.3	162.3	3.97	509.1	249.5
H14	8626	27	3544.1	426.4	6.68	1138.7	153.7	3.79	507.7	236.8
H14	8626	27	3544.1	426.4	6.68	1138.7	153.7	3.79	507.7	236.8
H14	8373	30	3457.0	419.0	6.66	1153.3	153.4	3.85	497.0	236.1
CB146	7912	37	3442.4	421.6	6.65	1304.2	164.8	4.09	495.2	251.5
14WF	7623	42	3526.0	427.4	6.74	1331.2	166.1	4.14	500.3	253.4
CB146N	7643	42	3525.4	427.3	6.74	1331.5	166.2	4.14	500.3	253.5
H14	8390	30	3402.1	412.4	6.65	1095.6	148.3	3.77	489.5	228.4
H14	8064	34	3413.4	416.9	6.65	1209.0	156.5	3.96	490.6	240.5
H14	8390	30	3402.1	412.4	6.65	1095.6	148.3	3.77	489.5	228.4
H14b	8134	34	3315.4	404.9	6.63	1108.7	147.8	3.83	479.0	227.5
CB146	7647	42	3280.0	405.1	6.61	1247.1	158.0	4.08	474.3	241.1
CB146N	7409	47	3372.3	412.0	6.71	1278.6	159.9	4.13	480.9	243.8
14WF	7389	48	3372.6	412.0	6.71	1278.1	159.9	4.13	480.8	243.8
H14	7826	38	3270.6	402.5	6.62	1161.2	150.7	3.94	472.2	231.5
H14	8152	33	3262.7	398.5	6.62	1053.2	142.9	3.76	471.8	220.1
H14	8152	33	3262.7	398.5	6.62	1053.2	142.9	3.76	471.8	220.1
H14b	7895	38	3176.3	390.9	6.60	1064.7	142.3	3.82	460.9	219.0
CB146N	7173	53	3228.6	397.4	6.68	1227.1	153.9	4.12	462.3	234.5
14WF	7154	54	3228.9	397.4	6.68	1226.6	153.9	4.12	462.2	234.5
H14	7913	37	3125.8	384.7	6.59	1011.3	137.6	3.50	453.9	211.8
CB146	7379	48	3119.6	388.7	6.58	1190.6	151.3	4.06	453.4	230.7
H14	7585	43	3130.4	388.3	6.59	1114.2	145.0	3.93	454.0	222.7
H14	7913	37	3125.8	384.7	6.59	1011.3	137.6	3.75	453.9	211.8
H14b	7655	42	3039.9	377.0	6.57	1021.4	136.9	3.81	443.3	210.6
14WF	6918	61	3080.9	382.2	6.65	1174.8	147.7	4.11	443.1	225.0
CB146N	6935	61	3080.2	382.2	6.65	1175.0	147.7	4.11	443.2	225.0
H14	7672	42	2991.5	371.0	6.56	970.0	132.3	3.74	436.6	203.7
H14	7345	49	2992.9	374.1	6.56	1067.8	139.3	3.92	436.0	213.9
H14	7672	42	2991.5	371.0	6.56	970.0	132.3	3.74	436.6	203.7
CB146	7106	55	2961.9	372.4	6.55	1134.5	144.6	4.05	432.7	220.3
H14b	7414	48	2905.9	363.2	6.55	978.7	131.5	3.80	425.6	202.3
H14	7429	48	2859.6	357.5	6.53	929.4	127.1	3.72	419.2	195.6
14WF	6680	70	2942.4	367.8	6.62	1124.8	141.8	4.10	424.9	215.9
CB146N	6697	69	2941.4	367.7	6.62	1124.7	141.8	4.10	424.9	215.9

Table 2.3.1 Dimensions and Primary Properties -- Steel Sections 1887-1952

Designation	Source Reference Number	Wt. per ft lb	Area	Depth	Web Thickness	Flange Width	Average Flange Thickness	Distance	Distance	Compact Section Criteria		
			A	d	t _w	b _f	t _f	T	k	b _f /2t _f	h/t _w	F _y "
			in.2	in.	in.	in.	in.	in.	in.	in.		
H14	2	227.5	66.98	16.00	1.130	14.620	1.813	11.112	2.444	4.03	9.8	-
H14	5	227.0	66.94	15.88	1.070	15.290	1.746	11.113	2.381	4.38	10.4	-
CB146	10	225.0	66.17	15.76	1.056	15.650	1.687	10.965	2.400	4.64	10.4	-
H14a	1	222.3	65.39	15.88	1.090	14.840	1.749	11.118	2.381	4.24	10.2	-
H14	4	220.5	64.52	15.88	1.090	14.580	1.750	11.118	2.381	4.17	10.2	-
H14	2	219.5	64.52	15.88	1.090	14.580	1.750	11.118	2.381	4.17	10.2	-
H14d	7	219.0	64.44	15.87	1.010	15.830	1.623	11.299	2.286	4.88	11.2	-
CB146N	12	219.0	64.42	15.87	1.010	15.830	1.623	11.199	2.336	4.88	11.1	-
H14	5	219.0	64.40	15.75	1.030	15.250	1.684	11.112	2.319	4.53	10.8	-
14WF	8 9 13 14 15	219.0	64.36	15.87	1.005	15.825	1.623	11.299	2.286	4.88	11.2	-
CB146	10	215.0	63.23	15.62	1.010	15.604	1.616	10.965	2.329	4.83	10.9	-
H14a	1	214.4	63.07	15.75	1.060	14.810	1.686	11.112	2.319	4.39	10.5	-
H14	4	212.0	62.07	15.75	1.050	14.540	1.688	11.112	2.319	4.31	10.6	-
14WF	7 8 9 13 14 15	211.0	62.07	15.75	0.980	15.800	1.563	11.299	2.226	5.05	11.5	-
H14	2	211.0	62.07	15.75	1.050	14.540	1.688	11.112	2.319	4.31	10.6	-
CB146N	12	211.0	62.04	15.75	0.980	15.800	1.563	11.199	2.276	5.05	11.4	-
H14	5	210.0	61.86	15.63	0.990	15.210	1.621	11.113	2.256	4.69	11.2	-
H14a	1	206.0	60.59	15.63	1.020	14.770	1.624	11.118	2.256	4.55	10.9	-
CB146	10	205.0	60.28	15.48	0.965	15.559	1.544	10.965	2.257	5.04	11.4	-
H14	4	204.5	59.78	15.63	1.020	14.510	1.625	11.118	2.256	4.46	10.9	-
H14	2	203.5	59.78	15.63	1.020	14.510	1.625	11.118	2.256	4.46	10.9	-
H14	5	202.0	59.50	15.50	0.960	15.180	1.559	11.112	2.194	4.87	11.6	-
14WF	7 8 9 13 14 15	202.0	59.39	15.63	0.930	15.750	1.503	11.299	2.166	5.24	12.1	-
CB146N	12	202.0	59.38	15.63	0.931	15.751	1.503	11.199	2.216	5.24	12.0	-
H14a	1	197.6	58.12	15.50	0.980	14.730	1.561	11.112	2.194	4.72	11.3	-
H14	4	196.0	57.35	15.50	0.980	14.470	1.563	11.112	2.194	4.63	11.3	-
H14	2	195.0	57.35	15.50	0.980	14.470	1.563	11.112	2.194	4.63	11.3	-
CB146	10	195.0	57.34	15.33	0.919	15.513	1.472	10.965	2.185	5.27	11.9	-
H14	5	194.0	56.99	15.38	0.920	15.140	1.496	11.113	2.131	5.06	12.1	-
CB146N	12	193.0	56.75	15.50	0.893	15.713	1.438	11.199	2.151	5.46	12.5	-
14WF	7 8 9 13 14 15	193.0	56.73	15.50	0.890	15.710	1.438	11.299	2.101	5.46	12.7	-
H14a	1	189.3	55.67	15.38	0.940	14.690	1.499	11.118	2.131	4.90	11.8	-
H14	4	187.5	54.92	15.38	0.940	14.430	1.500	11.118	2.131	4.81	11.8	-
H14	2	186.5	54.92	15.38	0.940	14.430	1.500	11.118	2.131	4.81	11.8	-
H14	5	185.0	54.48	15.25	0.880	15.100	1.434	11.112	2.069	5.27	12.6	-
CB146	10	185.0	54.41	15.19	0.875	15.469	1.399	10.965	2.112	5.53	12.5	-
H14d	7	184.0	54.15	15.38	0.845	15.665	1.378	11.299	2.041	5.68	13.4	-
CB146N	12	184.0	54.12	15.38	0.845	15.665	1.378	11.199	2.091	5.68	13.3	-
14WF	8 9 13 14 15	184.0	54.07	15.38	0.840	15.660	1.378	11.299	2.041	5.68	13.5	-
H14a	1	180.9	53.22	15.25	0.900	14.650	1.436	11.112	2.069	5.10	12.3	-
H14	4	179.5	52.51	15.25	0.900	14.390	1.438	11.112	2.069	5.01	12.3	-
H14	2	178.5	52.51	15.25	0.900	14.390	1.438	11.112	2.069	5.01	12.3	-
H14	5	177.0	51.99	15.13	0.840	15.060	1.371	11.113	2.006	5.49	13.2	-
CB146N	12	176.0	51.73	15.25	0.822	15.642	1.313	11.199	2.026	5.96	13.6	-
14WF	7 8 9 13 14 15	176.0	51.73	15.25	0.820	15.640	1.313	11.299	1.976	5.96	13.8	-
CB146	10	175.0	51.47	15.04	0.830	15.424	1.326	10.965	2.039	5.82	13.2	-
H14a	1	172.7	50.78	15.13	0.860	14.610	1.374	11.118	2.006	5.32	12.9	-
H14	4	171.5	50.11	15.13	0.860	14.350	1.375	11.118	2.006	5.22	12.9	-
H14	2	170.5	50.11	15.13	0.860	14.350	1.375	11.118	2.006	5.22	12.9	-
H14	5	168.0	49.51	15.00	0.800	15.020	1.309	11.112	1.944	5.74	13.9	-
CB146N	12	167.0	49.10	15.12	0.782	15.602	1.248	11.199	1.961	6.25	14.3	-
14WF	7 8 9 13 14 15	167.0	49.09	15.12	0.780	15.600	1.248	11.299	1.911	6.25	14.5	-
CB146	10	165.0	48.52	14.90	0.783	15.377	1.253	10.965	1.966	6.14	14.0	-
H14a	1	164.4	48.36	15.00	0.820	14.570	1.311	11.112	1.944	5.56	13.6	-
H14	4	163.0	47.71	15.00	0.820	14.310	1.313	11.112	1.944	5.45	13.6	-
H14	1	162.2	47.71	15.00	0.820	14.310	1.313	11.112	1.944	5.45	13.6	-
H14	2	162.0	47.71	15.00	0.820	14.310	1.313	11.112	1.944	5.45	13.6	-
H14	5	161.0	47.33	14.88	0.780	15.000	1.246	11.113	1.881	6.02	14.2	-
14WF	7 8 9 13 14 15	158.0	46.47	15.00	0.730	15.550	1.188	11.299	1.851	6.54	15.5	-
CB146N	12	158.0	46.44	15.00	0.730	15.550	1.188	11.199	1.901	6.54	15.3	-
H14	5	155.0	45.62	14.88	0.780	14.270	1.250	11.113	1.881	5.71	14.2	-
CB146	10	155.0	45.58	14.75	0.736	15.330	1.180	10.965	1.893	6.50	14.9	-
H14	4	155.0	45.33	14.88	0.780	14.270	1.250	11.118	1.881	5.71	14.3	-
H14	1	154.1	45.33	14.88	0.780	14.270	1.250	11.118	1.881	5.71	14.3	-
H14	2	154.0	45.33	14.88	0.780	14.270	1.250	11.118	1.881	5.71	14.3	-
H14	7	153.0	45.01	15.00	0.750	14.830	1.188	11.299	1.851	6.24	15.1	-
CB145N	12	153.0	44.98	15.00	0.750	14.828	1.188	11.199	1.901	6.24	14.9	-
H14	7	150.0	44.16	14.88	0.700	15.520	1.128	11.299	1.791	6.88	16.1	-
CB146N	12	150.0	44.13	14.88	0.700	15.520	1.128	11.199	1.841	6.88	16.0	-
14WF	8 9 13 14 15	150.0	44.08	14.88	0.695	15.515	1.128	11.299	1.791	6.88	16.3	-
H14b	6	149.0	43.82	14.13	1.410	14.900	0.875	11.113	1.506	8.51	7.9	-
H14b	4	149.0	43.52	14.13	1.410	14.900	0.875	11.113	1.506	8.51	7.9	-
H14c	1	148.0	43.52	14.13	1.410	14.900	0.875	11.113	1.506	8.51	7.9	-
H14	5	147.0	43.25	14.75	0.740	14.230	1.188	11.112	1.819	5.99	15.0	-
H14	4	147.0	42.95	14.75	0.740	14.230	1.188	11.112	1.819	5.99	15.0	-
H14	12	146.0	42.95	14.75	0.740	14.230	1.188	11.112	1.819	5.99	15.0	-

Table 2.3.1 Dimensions and Primary Properties -- Steel Sections 1887-1952

Designation	X ₁ ksi	X ₂ x 106 (1/ksi) ²	Elastic Properties						Plastic Modulus	
			Axis x-x			Axis y-y			Z _x in.3	Z _y in.3
			I _x in.4	S _x in.3	r _x in.	I _y in.4	S _y in.3	r _y in.		
H14	7429	48	2859.6	357.5	6.53	929.4	127.1	3.72	419.2	195.6
H14	7103	56	2857.8	360.0	6.53	1022.0	133.7	3.91	418.2	205.2
CB146	6833	64	2806.2	356.0	6.51	1079.1	137.9	4.04	412.2	210.0
H14a	7171	54	2774.5	349.5	6.51	936.6	126.2	3.78	408.4	194.1
H14	7186	54	2730.2	344.0	6.51	889.3	122.0	3.71	402.3	187.6
H14	7186	54	2730.2	344.0	6.51	889.3	122.0	3.71	402.3	187.6
H14d	6442	81	2799.9	352.8	6.59	1074.2	135.7	4.08	406.3	206.6
CB146N	6459	80	2798.8	352.7	6.59	1074.2	135.7	4.08	406.3	206.6
H14	6859	63	2725.3	346.1	6.51	976.9	128.1	3.89	400.6	196.6
14WF	6435	81	2798.2	352.6	6.59	1073.2	135.6	4.08	406.0	206.4
CB146	6556	75	2654.7	339.9	6.48	1024.5	131.3	4.03	391.9	199.9
H14a	6943	61	2648.7	336.3	6.48	897.0	121.1	3.77	391.8	186.2
H14	6943	61	2603.3	330.6	6.48	849.8	116.9	3.70	385.2	179.7
14WF	6223	92	2671.4	339.2	6.56	1028.6	130.2	4.07	389.4	198.1
H14	6943	61	2603.3	330.6	6.48	849.8	116.9	3.70	385.2	179.7
CB146N	6240	91	2670.4	339.1	6.56	1028.6	130.2	4.07	389.4	198.1
H14	6615	73	2595.4	332.2	6.48	932.4	122.6	3.88	383.2	188.1
H14a	6698	70	2522.1	322.8	6.45	856.0	115.9	3.76	374.9	178.1
CB146	6277	89	2505.0	323.7	6.45	970.3	124.7	4.01	371.8	189.8
H14	6713	70	2481.9	317.7	6.44	812.6	112.0	3.69	369.3	172.3
H14	6713	70	2481.9	317.7	6.44	812.6	112.0	3.69	369.3	172.3
H14	6385	83	2470.9	318.8	6.44	890.3	117.3	3.87	366.6	180.0
14WF	5976	107	2538.8	324.9	6.54	979.7	124.4	4.06	371.5	189.1
CB146N	5995	106	2538.1	324.8	6.54	979.8	124.4	4.06	371.5	189.2
H14a	6454	81	2397.9	309.3	6.42	815.6	110.7	3.75	358.0	170.1
H14	6467	81	2359.7	304.5	6.41	774.2	107.0	3.68	352.6	164.5
H14	6467	81	2359.7	304.5	6.41	774.2	107.0	3.68	352.6	164.5
CB146	5995	106	2358.2	307.6	6.41	916.8	118.2	4.00	351.8	179.7
H14	6139	97	2345.8	305.1	6.42	846.9	111.9	3.86	349.6	171.7
CB146N	5750	124	2402.3	310.0	6.51	930.6	118.5	4.05	353.3	180.0
14WF	5729	126	2402.4	310.0	6.51	930.1	118.4	4.05	353.1	180.0
H14a	6205	94	2276.1	296.1	6.39	775.8	105.6	3.73	341.6	162.3
H14	6220	94	2239.8	291.4	6.39	736.3	102.1	3.66	336.4	156.9
H14	6220	94	2239.8	291.4	6.39	736.3	102.1	3.66	336.4	156.9
H14	5892	113	2223.0	291.5	6.39	804.2	106.5	3.84	332.8	163.4
CB146	5712	127	2213.5	291.5	6.38	863.9	111.7	3.98	332.0	169.8
H14d	5489	148	2276.4	296.0	6.48	883.6	112.8	4.04	335.9	171.3
CB146N	5505	146	2275.3	295.9	6.48	883.6	112.8	4.04	335.9	171.3
14WF	5482	149	2274.8	295.8	6.49	882.7	112.7	4.04	335.6	171.2
H14a	5959	110	2156.7	282.8	6.37	736.5	100.5	3.72	325.1	154.4
H14	5974	109	2122.3	278.3	6.36	699.0	97.2	3.65	320.2	149.3
H14	5974	109	2122.3	278.3	6.36	699.0	97.2	3.65	320.2	149.3
H14	5644	134	2102.6	278.0	6.36	762.1	101.2	3.83	316.2	155.3
CB146N	5277	173	2149.1	281.9	6.45	838.2	107.2	4.03	319.0	162.8
14WF	5258	175	2149.6	281.9	6.45	837.9	107.1	4.02	318.9	162.7
CB146	5426	155	2071.7	275.5	6.34	811.6	105.2	3.97	312.4	159.9
H14a	5709	129	2039.5	269.7	6.34	697.9	95.5	3.71	309.0	146.7
H14	5725	129	2007.0	265.4	6.33	662.3	92.3	3.64	304.3	141.8
H14	5725	129	2007.0	265.4	6.33	662.3	92.3	3.64	304.3	141.8
H14	5396	159	1984.6	264.6	6.33	720.6	96.0	3.82	299.7	147.2
CB146N	5028	208	2020.4	267.2	6.41	790.5	101.3	4.01	301.3	153.8
14WF	5007	211	2020.8	267.3	6.42	790.2	101.3	4.01	301.1	153.8
CB146	5137	191	1932.6	259.5	6.31	759.9	98.8	3.96	292.9	150.0
H14a	5461	153	1924.7	256.6	6.32	659.8	90.6	3.69	292.9	139.1
H14	5476	152	1894.0	252.5	6.30	626.1	87.5	3.62	288.5	134.4
H14	5476	152	1894.0	252.5	6.31	625.1	87.4	3.62	288.5	134.4
H14	5476	152	1894.0	252.5	6.30	626.1	87.5	3.62	288.5	134.4
H14	5174	187	1874.4	252.0	6.29	682.5	91.0	3.80	284.6	139.7
14WF	4758	256	1900.6	253.4	6.40	745.0	95.8	4.00	284.2	145.3
CB146N	4774	253	1899.6	253.3	6.40	745.0	95.8	4.01	284.2	145.3
H14	5210	185	1793.8	241.2	6.27	590.6	82.8	3.60	272.9	127.1
CB146	4848	239	1796.8	243.6	6.28	709.0	92.5	3.94	273.7	140.3
H14	5224	183	1783.3	239.8	6.27	590.5	82.8	3.61	273.0	127.1
H14	5224	183	1783.3	239.8	6.27	589.5	82.6	3.61	273.0	127.1
H14	5224	183	1783.3	239.8	6.27	589.5	82.6	3.61	273.0	127.1
H14	4805	251	1822.2	243.0	6.36	646.3	87.2	3.79	273.2	132.4
CB145N	4824	248	1820.9	242.8	6.36	646.0	87.1	3.79	273.2	132.4
H14	4533	309	1788.3	240.4	6.36	703.2	90.6	3.99	268.6	137.4
CB146N	4551	305	1787.2	240.2	6.36	703.2	90.6	3.99	268.6	137.4
14WF	4527	311	1786.9	240.2	6.37	702.5	90.6	3.99	268.4	137.3
H14b	6108	130	1379.1	195.3	5.61	468.8	62.9	3.27	226.7	101.2
H14b	6134	128	1368.5	193.8	5.61	468.8	62.9	3.28	226.7	101.2
H14c	6134	128	1368.5	193.8	5.61	468.6	62.9	3.28	226.7	101.2
H14	4960	223	1685.3	228.5	6.24	555.5	78.1	3.58	257.5	119.9
H14	4973	220	1674.7	227.1	6.24	554.4	78.1	3.60	257.5	119.9
H14	4973	220	1674.7	227.1	6.24	554.4	77.9	3.59	257.5	119.9

Table 2.3.1 Dimensions and Primary Properties -- Steel Sections 1887-1952

Designation	Source Reference Number	Wt. per ft lb	Area	Depth	Web Thickness	Flange Width	Average Flange Thickness	Distance	Distance	Compact Section Criteria		
			A	d	t _w	b _f	t _f	T	k	b/2t _f	h/t _w	F _y "
			in.2	in.	in.	in.	in.	in.	in.			ksi
H14	7	145.0	42.64	14.88	0.710	14.790	1.128	11.299	1.791	6.56	15.9	-
CB146	10	145.0	42.64	14.60	0.690	15.284	1.106	10.965	1.819	6.91	15.9	-
CB145N	12	145.0	42.62	14.88	0.711	14.789	1.128	11.199	1.841	6.56	15.8	-
14WF	7 8 9 13 14 15	142.0	41.85	14.75	0.680	15.500	1.063	11.299	1.726	7.29	16.6	-
CB146N	12	142.0	41.76	14.75	0.680	15.500	1.061	11.199	1.774	7.30	16.5	-
H14	5	139.0	40.88	14.63	0.700	14.190	1.125	11.113	1.756	6.31	15.9	-
H14	4	139.0	40.59	14.63	0.700	14.190	1.125	11.118	1.756	6.31	15.9	-
H14	1 2	138.0	40.59	14.63	0.700	14.190	1.125	11.118	1.756	6.31	15.9	-
14WF	7 8 9 13 14 15	136.0	39.98	14.75	0.660	14.740	1.063	11.299	1.726	6.93	17.1	-
CB145N	12	136.0	39.98	14.75	0.662	14.740	1.063	11.199	1.776	6.93	16.9	-
CB146	10	135.0	39.70	14.45	0.645	15.239	1.031	10.965	1.744	7.39	17.0	-
H14	5	131.5	38.68	14.50	0.670	14.160	1.063	11.112	1.694	6.66	16.6	-
H14	4	131.5	38.38	14.50	0.670	14.160	1.063	11.112	1.694	6.66	16.6	-
CB146	10	131.0	38.52	14.16	0.874	15.468	0.886	10.965	1.599	8.73	12.5	-
H14	1 2	130.5	38.38	14.50	0.670	14.160	1.063	11.112	1.694	6.66	16.6	-
CB145N	12	127.0	37.33	14.62	0.612	14.690	0.998	11.199	1.711	7.36	18.3	-
14WF	7 8 9 13 14 15	127.0	37.33	14.62	0.610	14.690	0.998	11.299	1.661	7.36	18.5	-
CB146	10	125.0	36.75	14.30	0.597	15.191	0.957	10.965	1.670	7.94	18.4	-
H14	5	123.5	36.33	14.38	0.630	14.120	1.000	11.113	1.631	7.06	17.6	-
H14	4	123.5	36.04	14.38	0.630	14.120	1.000	11.118	1.631	7.06	17.6	-
H14	1 2	122.5	36.04	14.38	0.630	14.120	1.000	11.118	1.631	7.06	17.6	-
14WF	7 8 9 13 14 15	119.0	34.99	14.50	0.570	14.650	0.938	11.299	1.601	7.81	19.8	-
CB145N	12	119.0	34.97	14.50	0.571	14.649	0.938	11.199	1.651	7.81	19.6	-
H14	5	115.5	34.00	14.25	0.590	14.080	0.938	11.112	1.569	7.51	18.8	-
H14	4	115.5	33.70	14.25	0.590	14.080	0.938	11.112	1.569	7.51	18.8	-
CB146	10	115.5	33.82	14.15	0.551	15.145	0.882	10.965	1.595	8.59	19.9	-
H14	1	114.6	33.70	14.25	0.590	14.080	0.938	11.112	1.569	7.51	18.8	-
H14	2	114.5	33.70	14.25	0.590	14.080	0.938	11.112	1.569	7.51	18.8	-
14WF	7 8 9 13 14	111.0	32.65	14.37	0.540	14.620	0.873	11.299	1.536	8.37	20.9	-
CB145N	12	111.0	32.62	14.37	0.540	14.618	0.873	11.199	1.586	8.37	20.7	-
H14	5	107.5	31.67	14.13	0.550	14.040	0.875	11.113	1.506	8.02	20.2	-
H14	4	107.5	31.38	14.13	0.550	14.040	0.875	11.118	1.506	8.02	20.2	-
H14	1	106.7	31.38	14.13	0.550	14.040	0.875	11.118	1.506	8.02	20.2	-
H14	2	106.5	31.38	14.13	0.550	14.040	0.875	11.118	1.506	8.02	20.2	-
CB146	11	106.0	31.18	14.02	0.509	15.103	0.814	10.965	1.527	9.28	21.5	-
CB145N	10	105.0	30.88	14.37	0.536	12.101	0.990	10.965	1.703	6.11	20.5	-
CB145N	12	103.0	30.27	14.25	0.498	14.576	0.813	11.199	1.526	8.96	22.5	-
14WF	7 8 9 13 14 15	103.0	30.26	14.25	0.495	14.575	0.813	11.299	1.476	8.96	22.8	-
H14	5	100.0	29.36	14.00	0.510	14.000	0.813	11.112	1.444	8.62	21.8	-
H14	4	100.0	29.06	14.00	0.510	14.000	0.813	11.112	1.444	8.62	21.8	-
H14	2	99.0	29.06	14.00	0.510	14.000	0.813	11.112	1.444	8.62	21.8	-
H14	1	98.8	29.06	14.00	0.510	14.000	0.813	11.112	1.444	8.62	21.8	-
CB146N	11	96.0	28.23	13.87	0.462	15.056	0.738	10.965	1.451	10.20	23.7	-
14WF	7 8 9 13 14 15	95.0	27.94	14.12	0.465	14.545	0.748	11.299	1.411	9.72	24.3	-
CB145N	10	95.0	27.93	14.19	0.485	12.050	0.898	10.965	1.611	6.71	22.6	-
CB145N	12	95.0	27.92	14.12	0.466	14.544	0.748	11.199	1.461	9.72	24.0	-
H14s	1	93.7	27.56	14.00	0.510	13.000	0.818	11.112	1.444	7.95	21.8	-
H14	5	92.0	27.05	13.88	0.470	13.960	0.750	11.113	1.381	9.31	23.6	-
H14	4	92.0	26.76	13.88	0.470	13.960	0.750	11.118	1.381	9.31	23.7	-
H14	2	91.0	26.76	13.88	0.470	13.960	0.750	11.118	1.381	9.31	23.7	-
H14/12	5	90.0	26.52	14.00	0.510	12.120	0.822	11.112	1.444	7.37	21.8	-
H14/12	3	90.0	26.22	14.00	0.510	12.120	0.822	11.112	1.444	7.37	21.8	-
H14s	1	89.2	26.23	14.00	0.520	12.040	0.823	11.112	1.444	7.32	21.4	-
CB145N	12	87.0	25.56	14.00	0.422	14.500	0.688	11.199	1.401	10.54	26.5	-
14WF	7 8 9 13 14 15	87.0	25.56	14.00	0.420	14.500	0.688	11.299	1.351	10.54	26.9	-
CB146	11	86.0	25.28	13.71	0.414	15.008	0.662	10.965	1.375	11.34	26.5	-
CB145	10	85.0	24.99	14.00	0.435	12.000	0.805	10.965	1.518	7.45	25.2	-
H14	5	84.0	24.76	13.75	0.430	13.920	0.688	11.112	1.319	10.12	25.8	-
14WF	7 8 9 13 14 15	84.0	24.71	14.18	0.451	12.023	0.778	11.299	1.441	7.73	25.1	-
H14a	7	84.0	24.69	14.18	0.450	12.020	0.778	11.299	1.441	7.72	25.1	-
CB144N	12	84.0	24.68	14.18	0.451	12.021	0.778	11.199	1.491	7.73	24.8	-
H14	4	84.0	24.46	13.75	0.430	13.920	0.688	11.112	1.319	10.12	25.8	-
H14	2	83.5	24.46	13.75	0.430	13.920	0.688	11.112	1.319	10.12	25.8	-
H14/12	5	83.0	24.45	13.88	0.470	12.080	0.759	11.113	1.381	7.96	23.6	-
H14/12	3	83.0	24.15	13.88	0.470	12.080	0.759	11.118	1.381	7.96	23.7	-
H14s	1	82.2	24.17	13.88	0.480	12.000	0.760	11.118	1.381	7.90	23.2	-
H14s	7	78.0	22.97	14.06	0.430	12.000	0.718	11.299	1.381	8.36	26.3	-
14WF	7 8 9 13 14 15	78.0	22.94	14.06	0.428	12.000	0.718	11.299	1.381	8.36	26.4	-
CB144N	12	78.0	22.94	14.06	0.430	12.000	0.718	11.199	1.431	8.36	26.0	-
H14s	1	77.6	22.81	13.88	0.480	11.040	0.765	11.118	1.381	7.22	23.2	-
H14/12	5	76.0	22.39	13.75	0.430	12.040	0.697	11.112	1.319	8.64	25.8	-
H14/12	3	76.0	22.09	13.75	0.430	12.040	0.697	11.112	1.319	8.64	25.8	-
CB144	10	75.0	22.05	14.38	0.468	10.086	0.786	11.585	1.399	6.42	24.8	-
14WF	7 8 9 13 14 15	74.0	21.76	14.19	0.450	10.072	0.783	11.299	1.446	6.43	25.1	-
H14b	7	74.0	21.76	14.19	0.450	10.070	0.783	11.299	1.446	6.43	25.1	-
CB143N	12	74.0	21.75	14.19	0.451	10.071	0.783	11.199	1.496	6.43	24.8	-

Table 2.3.1 Dimensions and Primary Properties – Steel Sections 1887-1952

Designation	X ₁ ksi	X ₂ x 106 (1/ksi) ²	Elastic Properties						Plastic Modulus	
			Axis x-x			Axis y-y			Z _x in.3	Z _y in.3
			I _x in.4	S _x in.3	r _x in.	I _y in.4	S _y in.3	r _y in.		
H14	4568	306	1711.9	230.1	6.34	608.7	82.3	3.78	257.7	125.0
CB146	4554	304	1662.7	227.7	6.24	658.5	86.2	3.93	254.6	130.7
CB145N	4586	301	1710.9	230.0	6.34	608.5	82.3	3.78	257.7	125.0
14WF	4308	379	1672.2	226.7	6.32	660.1	85.2	3.97	252.6	129.2
CB146N	4319	376	1667.8	226.2	6.32	658.9	85.0	3.97	252.1	128.9
H14	4708	272	1578.9	215.9	6.21	520.9	73.4	3.57	242.3	112.7
H14	4722	269	1568.4	214.5	6.21	520.9	73.4	3.58	242.4	112.7
H14	4722	269	1568.4	214.5	6.21	519.7	73.3	3.58	242.4	112.7
14WF	4300	384	1593.0	216.0	6.31	567.7	77.0	3.77	240.8	116.9
CB145N	4321	377	1592.3	215.9	6.31	567.7	77.0	3.77	240.8	116.9
CB146	4258	394	1530.4	211.8	6.21	608.4	79.9	3.92	235.6	121.0
H14	4469	334	1477.3	203.8	6.18	488.0	68.9	3.55	227.8	105.9
H14	4484	329	1466.7	202.3	6.18	487.9	68.9	3.57	227.8	105.9
CB146	4266	440	1358.4	191.8	5.94	547.3	70.8	3.77	215.5	108.4
H14	4484	329	1466.7	202.3	6.18	486.9	68.8	3.56	227.8	105.9
CB145N	4053	481	1476.0	201.9	6.29	527.6	71.8	3.76	224.1	108.9
14WF	4032	491	1476.7	202.0	6.29	527.6	71.8	3.76	224.0	108.9
CB146	3961	521	1402.1	196.0	6.18	559.4	73.7	3.90	216.9	111.5
H14	4216	418	1375.1	191.3	6.15	454.4	64.4	3.54	213.0	98.9
H14	4231	412	1364.6	189.9	6.16	454.4	64.4	3.55	213.0	98.9
H14	4231	412	1364.6	189.9	6.16	453.4	64.2	3.55	213.0	98.9
14WF	3792	622	1373.1	189.4	6.26	491.8	67.1	3.75	209.1	101.7
CB145N	3811	610	1372.2	189.3	6.26	491.7	67.1	3.75	209.1	101.7
H14	3962	532	1275.1	179.0	6.12	421.4	59.9	3.52	198.3	92.0
H14	3977	523	1264.5	177.5	6.13	421.3	59.9	3.54	198.3	92.0
CB146	3661	707	1275.9	180.3	6.14	510.9	67.5	3.89	198.4	102.1
H14	3977	523	1264.5	177.5	6.13	420.3	59.7	3.53	198.3	92.0
H14	3977	523	1264.5	177.5	6.13	420.3	59.7	3.53	198.3	92.0
14WF	3549	806	1266.5	176.3	6.23	454.9	62.2	3.73	193.8	94.2
CB145N	3568	790	1265.3	176.1	6.23	454.7	62.2	3.73	193.8	94.2
H14	3707	687	1177.2	166.7	6.10	388.9	55.4	3.50	183.8	85.1
H14	3724	675	1166.6	165.2	6.10	388.9	55.4	3.52	183.9	85.1
H14	3724	675	1166.6	165.2	6.10	387.8	55.2	3.52	183.9	85.1
H14	3724	675	1166.6	165.2	6.10	387.8	55.2	3.52	183.9	85.1
CB146	3390	953	1164.1	166.1	6.11	467.6	61.9	3.87	181.9	93.6
CB145N	4063	484	1169.6	162.8	6.15	292.6	48.4	3.08	180.9	73.4
CB145N	3324	1036	1165.4	163.6	6.20	419.8	57.6	3.72	179.1	87.1
14WF	3304	1062	1165.8	163.6	6.21	419.7	57.6	3.72	178.9	87.1
H14	3453	905	1081.2	154.5	6.07	356.9	51.0	3.49	169.5	78.4
H14	3469	888	1070.6	153.0	6.07	356.9	51.0	3.50	169.5	78.4
H14	3469	888	1070.6	153.0	6.07	356.9	51.0	3.50	169.5	78.4
H14	3469	888	1070.6	153.0	6.07	355.9	50.8	3.50	169.5	78.4
CB146N	3086	1373	1042.1	150.3	6.08	419.9	55.8	3.86	163.6	84.3
14WF	3060	1437	1063.5	150.6	6.17	383.7	52.8	3.71	164.0	79.8
CB145N	3699	695	1044.0	147.2	6.11	262.0	43.5	3.06	162.4	65.9
CB145N	3080	1401	1062.5	150.5	6.17	383.7	52.8	3.71	164.0	79.8
H14s	3514	861	1004.7	143.5	6.04	288.5	44.4	3.24	159.6	68.3
H14	3199	1217	987.4	142.3	6.04	325.5	46.6	3.47	155.4	71.7
H14	3216	1193	976.8	140.8	6.04	325.4	46.6	3.49	155.5	71.7
H14	3216	1193	976.8	140.8	6.04	325.4	46.6	3.49	155.5	71.7
H14/12	3534	858	956.7	136.7	6.01	235.8	38.9	2.98	150.7	59.9
H14/12	3553	839	946.1	135.2	6.01	235.8	38.9	3.00	150.7	59.9
H14s	3577	825	942.4	134.6	5.99	231.4	38.4	2.97	150.3	59.2
CB145N	2835	1928	966.2	138.0	6.15	349.7	48.2	3.70	149.6	72.9
14WF	2813	1987	966.9	138.1	6.15	349.7	48.2	3.70	149.5	72.9
CB146	2780	2060	923.0	134.6	6.04	373.1	49.7	3.84	145.6	75.1
CB145	3333	1042	921.3	131.6	6.07	232.0	38.7	3.05	144.2	58.5
H14	2945	1679	895.5	130.2	6.01	294.5	42.3	3.45	141.5	65.1
14WF	3193	1261	928.4	130.9	6.13	225.5	37.5	3.02	143.3	56.9
H14a	3190	1263	928.0	130.9	6.13	225.3	37.5	3.02	143.3	56.8
CB144N	3213	1228	927.2	130.8	6.13	225.4	37.5	3.02	143.3	56.9
H14	2962	1641	884.9	128.7	6.01	294.5	42.3	3.47	141.5	65.1
H14	2962	1641	884.9	128.7	6.01	294.5	42.3	3.47	141.5	65.1
H14/12	3275	1154	874.2	126.0	5.98	215.1	35.6	2.97	138.2	54.8
H14/12	3294	1127	863.6	124.5	5.98	215.0	35.6	2.98	138.2	54.8
H14s	3316	1108	860.4	124.0	5.97	211.0	35.2	2.96	137.9	54.1
H14s	2976	1672	851.5	121.1	6.09	206.9	34.5	3.00	132.1	52.3
14WF	2972	1678	851.2	121.1	6.09	206.9	34.5	3.00	132.0	52.3
CB144N	2997	1623	850.5	121.0	6.09	206.9	34.5	3.00	132.1	52.3
H14s	3368	1069	800.6	115.4	5.93	165.9	30.1	2.70	129.0	46.3
H14/12	3019	1581	793.5	115.4	5.95	194.7	32.3	2.95	125.9	49.8
H14/12	3038	1540	782.9	113.9	5.95	194.7	32.3	2.97	125.9	49.8
CB144	3249	1259	823.5	114.5	6.11	134.5	26.7	2.47	127.0	40.7
14WF	3266	1215	796.8	112.3	6.05	133.5	26.5	2.48	123.7	40.4
H14b	3265	1216	796.7	112.3	6.05	133.4	26.5	2.48	123.6	40.3
CB143N	3293	1177	795.9	112.2	6.05	133.4	26.5	2.48	123.7	40.3

Table 2.3.1 Dimensions and Primary Properties -- Steel Sections 1887-1952

Designation	Source Reference Number	Wt. per ft lb	Area	Depth	Web Thickness	Flange Width	Average Flange Thickness	Distance	Distance	Compact Section Criteria		
			A	d	t _w	b _f	t _f	T	k	b _f /2t _f	h/t _w	F _y "
			in.2	in.	in.	in.	in.	in.	in.	in.		
H14/10	5	73.5	21.66	13.88	0.470	10.120	0.769	11.113	1.381	6.58	23.6	-
H14/10	3	73.5	21.37	13.88	0.470	10.120	0.769	11.118	1.381	6.58	23.7	-
H14s	1	71.0	20.88	13.75	0.440	11.000	0.702	11.112	1.319	7.83	25.3	-
H14/12	5	69.0	20.34	13.63	0.390	12.000	0.634	11.113	1.256	9.46	28.5	-
H14/12	3	69.0	20.04	13.63	0.390	12.000	0.634	11.118	1.256	9.46	28.5	-
H14b	7	68.0	20.03	14.06	0.420	10.040	0.718	11.299	1.381	6.99	26.9	-
CB143N	12	68.0	20.00	14.08	0.420	10.040	0.718	11.219	1.431	6.99	26.7	-
14WF	8 9 13 14 15	68.0	20.00	14.06	0.418	10.040	0.718	11.299	1.381	6.99	27.0	-
CB144	10	68.0	19.99	14.24	0.425	10.043	0.714	11.585	1.327	7.03	27.3	-
H14/10	5	67.5	19.85	13.75	0.430	10.080	0.707	11.112	1.319	7.13	25.8	-
H14/10	3	67.5	19.55	13.75	0.430	10.080	0.707	11.112	1.319	7.13	25.8	-
H14s	1	66.7	19.61	13.75	0.440	10.030	0.707	11.112	1.319	7.09	25.3	-
H14/10	5	61.5	18.04	13.63	0.390	10.040	0.644	11.113	1.256	7.80	28.5	-
H14/10	3	61.5	17.75	13.63	0.390	10.040	0.644	11.118	1.256	7.80	28.5	-
H14b	7	61.0	17.97	13.91	0.380	10.000	0.643	11.299	1.306	7.78	29.7	-
H14s	1	61.0	17.95	13.63	0.410	10.000	0.645	11.118	1.256	7.76	27.1	-
CB144	10	61.0	17.94	14.09	0.382	10.000	0.642	11.585	1.255	7.79	30.3	-
14WF	8 9 13 14 15	61.0	17.94	13.91	0.378	10.000	0.643	11.299	1.306	7.78	29.9	-
CB143N	12	61.0	17.94	13.91	0.380	10.000	0.643	11.199	1.356	7.78	29.5	-
H14/8	5	58.5	17.23	13.75	0.430	8.120	0.717	11.112	1.319	5.67	25.8	-
H14/8	3	58.5	16.93	13.75	0.430	8.120	0.717	11.112	1.319	5.67	25.8	-
14WF	8 13 15	58.0	17.06	14.06	0.406	8.098	0.718	11.299	1.381	5.64	27.8	-
H14c	7	58.0	17.05	14.06	0.405	8.095	0.718	11.299	1.381	5.64	27.9	-
CB143N	10	58.0	17.05	14.24	0.413	8.070	0.716	11.585	1.329	5.64	28.1	-
CB142N	12	58.0	17.03	14.06	0.406	8.096	0.718	11.199	1.431	5.64	27.6	-
H14s	1	57.1	16.79	13.36	0.410	9.040	0.649	10.848	1.256	6.96	26.5	-
H14/10	5	55.0	16.25	13.50	0.350	10.000	0.582	11.112	1.194	8.60	31.7	64
H14/10	3	55.0	15.95	13.50	0.350	10.000	0.582	11.112	1.194	8.60	31.7	64
H14/8	5	53.5	15.67	13.63	0.390	8.080	0.654	11.113	1.256	6.18	28.5	-
H14/8	3	53.5	15.37	13.63	0.390	8.080	0.654	11.118	1.256	6.18	28.5	-
CB143	10	53.0	15.39	14.12	0.378	8.035	0.656	11.585	1.269	6.12	30.6	-
14WF	8 9 13 14 15	53.0	15.59	13.94	0.370	8.062	0.658	11.299	1.321	6.13	30.5	-
H14c	7	53.0	15.59	13.94	0.370	8.060	0.658	11.299	1.321	6.12	30.5	-
CB142N	12	53.0	15.56	13.94	0.370	8.060	0.658	11.199	1.371	6.12	30.3	-
H14s	1	51.4	15.12	13.50	0.370	9.000	0.587	11.112	1.194	7.67	30.0	-
CB143	10	48.0	14.12	14.00	0.343	8.000	0.595	11.585	1.208	6.72	33.8	56
H14c	7	48.0	14.12	13.81	0.340	8.030	0.593	11.299	1.256	6.77	33.2	58
H14/8	5	48.0	14.12	13.50	0.350	8.040	0.592	11.112	1.194	6.80	31.7	64
14WF	8 9 13 14 15	48.0	14.11	13.81	0.339	8.031	0.593	11.299	1.256	6.77	33.3	58
CB142N	15	48.0	14.10	13.81	0.340	8.030	0.593	11.199	1.306	6.77	32.9	59
H14/8	12	48.0	13.82	13.50	0.350	8.040	0.592	11.112	1.194	6.80	31.7	64
H14s	3	47.8	14.07	13.50	0.370	8.040	0.592	11.112	1.194	6.80	30.0	-
H14c	1	43.0	12.67	13.68	0.310	8.000	0.528	11.299	1.191	7.58	36.4	48
14WF	7	43.0	12.65	13.68	0.308	8.000	0.528	11.299	1.191	7.58	36.7	48
CB142N	12	43.0	12.64	13.68	0.310	8.000	0.528	11.199	1.241	7.58	36.1	49
H14/8	5	43.0	12.58	13.38	0.310	8.000	0.529	11.113	1.131	7.56	35.8	50
H14/8	1	43.0	12.28	13.38	0.310	8.000	0.529	11.118	1.131	7.56	35.9	50
H15s	1	42.6	12.53	13.38	0.330	8.000	0.529	11.118	1.131	7.56	33.7	57
H13b	1	285.9	84.09	15.88	1.410	15.160	2.244	10.123	2.876	3.38	7.2	-
H13b	1	277.3	81.56	15.75	1.370	15.120	2.181	10.122	2.814	3.47	7.4	-
H13b	1	268.8	79.05	15.63	1.330	15.080	2.119	10.123	2.751	3.56	7.6	-
H13b	1	260.2	76.54	15.50	1.290	15.040	2.056	10.122	2.689	3.66	7.8	-
H13b	1	251.8	74.05	15.38	1.250	15.000	1.994	10.123	2.626	3.76	8.1	-
H13b	1	243.3	71.56	15.25	1.210	14.960	1.931	10.122	2.564	3.87	8.4	-
H13b	1	234.9	69.09	15.13	1.170	14.920	1.869	10.123	2.501	3.99	8.7	-
H13b	1	226.5	66.62	15.00	1.130	14.880	1.806	10.122	2.439	4.12	9.0	-
H13a	1	219.8	64.64	15.00	1.130	14.310	1.809	10.122	2.439	3.96	9.0	-
H13a	1	211.7	62.25	14.88	1.090	14.270	1.747	10.123	2.376	4.09	9.3	-
H13a	1	204.1	60.03	14.75	1.060	14.240	1.684	10.122	2.314	4.23	9.5	-
H13a	1	196.1	57.66	14.63	1.020	14.200	1.622	10.123	2.251	4.38	9.9	-
H13a	1	188.0	55.31	14.50	0.980	14.160	1.559	10.122	2.189	4.54	10.3	-
H13a	1	180.1	52.96	14.38	0.940	14.120	1.497	10.123	2.126	4.72	10.8	-
H13a	1	172.1	50.63	14.25	0.900	14.080	1.434	10.122	2.064	4.91	11.2	-
H13a	1	164.2	48.30	14.13	0.860	14.040	1.372	10.123	2.001	5.12	11.8	-
H13a	1	156.4	45.99	14.00	0.820	14.000	1.309	10.122	1.939	5.35	12.3	-
H13	1	150.5	44.27	14.00	0.820	13.310	1.313	10.122	1.939	5.07	12.3	-
H13	1	143.0	42.05	13.88	0.780	13.270	1.250	10.123	1.876	5.31	13.0	-
H13c	1	141.0	41.48	13.13	1.410	14.590	0.872	10.123	1.501	8.37	7.2	-
H13	1	135.5	39.84	13.75	0.740	13.230	1.188	10.122	1.814	5.57	13.7	-
H13	1	128.0	37.64	13.63	0.700	13.190	1.125	10.123	1.751	5.86	14.5	-
H13	1	121.0	35.59	13.50	0.670	13.160	1.063	10.122	1.689	6.19	15.1	-
H13	1	113.6	33.41	13.38	0.630	13.120	1.000	10.123	1.626	6.56	16.1	-
H13	1	106.2	31.24	13.25	0.590	13.080	0.938	10.122	1.564	6.98	17.2	-
H13	1	98.9	29.08	13.13	0.550	13.040	0.875	10.123	1.501	7.45	18.4	-
H13	1	91.5	26.93	13.00	0.510	13.000	0.813	10.122	1.439	8.00	19.8	-

Table 2.3.1 Dimensions and Primary Properties – Steel Sections 1887-1952

Designation	X ₁ ksi	X ₂ x 106 (1/ksi) ²	Elastic Properties						Plastic Modulus	
			Axis x-x			Axis y-y			Z _x in.3	Z _y in.3
			I _x	S _x	r _x	I _y	S _y	r _y		
			in.4	in.3	in.	in.4	in.3	in.		
H14/10	3371	1083	753.3	108.6	5.90	129.1	25.5	2.44	119.9	39.3
H14/10	3396	1054	742.7	107.1	5.90	129.0	25.5	2.46	119.9	39.3
H14s	3106	1462	727.0	105.7	5.90	150.2	27.3	2.68	117.5	42.1
H14/12	2758	2246	714.6	104.9	5.93	174.7	29.1	2.93	113.7	44.8
H14/12	2780	2180	704.0	103.3	5.93	174.7	29.1	2.95	113.8	44.8
H14b	3020	1657	724.4	103.0	6.01	121.2	24.1	2.46	112.9	36.7
CB143N	3045	1606	723.4	102.9	6.01	121.2	24.1	2.46	113.1	36.7
14WF	3015	1664	724.1	103.0	6.02	121.2	24.1	2.46	112.8	36.7
CB144	2962	1806	738.8	103.8	6.08	120.6	24.0	2.46	114.4	36.6
H14/10	3110	1482	684.3	99.5	5.87	116.8	23.2	2.43	109.2	35.7
H14/10	3134	1438	673.7	98.0	5.87	116.8	23.2	2.44	109.2	35.7
H14s	3158	1409	672.5	97.8	5.84	115.1	23.0	2.42	109.2	35.4
H14/10	2844	2091	616.9	90.6	5.85	104.8	20.9	2.41	98.8	32.2
H14/10	2872	2019	606.3	89.0	5.84	104.8	20.9	2.43	98.8	32.2
H14b	2724	2481	641.8	92.3	5.98	107.3	21.5	2.44	100.4	32.6
H14s	2913	1942	607.5	89.2	5.82	103.7	20.7	2.40	99.3	32.0
CB144	2676	2684	656.2	93.1	6.05	107.1	21.4	2.44	102.0	32.6
14WF	2722	2487	641.5	92.2	5.98	107.3	21.5	2.45	100.4	32.6
CB143N	2753	2381	640.8	92.1	5.98	107.3	21.5	2.45	100.4	32.6
H14/8	3226	1378	572.2	83.2	5.76	62.4	15.4	1.90	92.1	23.8
H14/8	3256	1329	561.6	81.7	5.76	62.4	15.4	1.92	92.1	23.8
14WF	3072	1648	597.9	85.0	5.92	63.7	15.7	1.93	93.8	24.1
H14c	3069	1653	597.5	85.0	5.92	63.6	15.7	1.93	93.7	24.0
CB143N	3024	1777	609.4	85.6	5.98	62.8	15.6	1.92	95.1	23.9
CB142N	3102	1584	596.7	84.9	5.92	63.6	15.7	1.93	93.7	24.1
H14s	2963	1799	558.5	82.0	5.77	77.5	17.1	2.15	89.5	26.5
H14/10	2585	3036	551.0	81.6	5.82	93.1	18.6	2.39	88.4	28.7
H14/10	2609	2926	540.4	80.1	5.82	93.1	18.6	2.42	88.4	28.7
H14/8	2955	1932	516.2	75.8	5.74	56.0	13.9	1.89	83.3	21.4
H14/8	2989	1853	505.6	74.2	5.74	56.0	13.9	1.91	83.4	21.4
CB143	2767	2455	552.5	78.2	5.95	56.8	14.1	1.91	86.5	21.6
14WF	2824	2282	542.1	77.8	5.90	57.5	14.3	1.92	85.2	21.8
H14c	2823	2283	542.0	77.8	5.90	57.5	14.3	1.92	85.2	21.8
CB142N	2858	2178	541.0	77.6	5.90	57.5	14.3	1.92	85.2	21.8
H14s	2707	2670	498.3	73.8	5.75	68.8	15.3	2.13	82.3	23.7
CB143	2536	3526	496.0	70.9	5.93	50.8	12.7	1.90	77.9	19.4
H14c	2576	3287	485.0	70.2	5.86	51.2	12.8	1.90	76.5	19.5
H14/8	2686	2792	461.5	68.4	5.72	49.7	12.4	1.88	74.7	19.1
14WF	2573	3296	484.9	70.2	5.86	51.3	12.8	1.91	76.5	19.5
CB142N	2609	3123	484.0	70.1	5.86	51.2	12.8	1.91	76.5	19.5
H14/8	2721	2663	450.9	66.8	5.71	49.7	12.4	1.90	74.7	19.1
H14s	2765	2553	454.1	67.3	5.68	49.7	12.4	1.88	75.4	19.2
H14c	2325	4933	429.3	62.8	5.82	45.1	11.3	1.89	67.9	17.2
14WF	2324	4948	429.0	62.7	5.82	45.1	11.3	1.89	67.8	17.2
CB142N	2363	4629	428.3	62.6	5.82	45.1	11.3	1.89	67.9	17.2
H14/8	2422	4180	408.2	61.0	5.70	43.6	10.9	1.86	66.1	16.8
H14/8	2453	3979	397.6	59.5	5.69	43.6	10.9	1.88	66.1	16.8
H15s	2500	3787	400.8	59.9	5.66	43.6	10.9	1.87	66.9	16.9
H13b	9749	17	3361.9	423.6	6.32	1287.6	169.9	3.91	509.3	261.3
H13b	9500	18	3230.5	410.2	6.29	1241.2	164.2	3.90	491.9	252.5
H13b	9249	20	3101.5	396.9	6.26	1195.4	158.5	3.89	474.6	243.8
H13b	8993	22	2974.9	383.9	6.24	1150.2	152.9	3.88	457.5	235.1
H13b	8741	25	2850.8	370.8	6.21	1105.7	147.4	3.86	440.6	226.6
H13b	8484	28	2729.1	357.9	6.18	1061.8	141.9	3.85	424.0	218.1
H13b	8226	31	2609.7	345.1	6.15	1018.5	136.5	3.84	407.5	209.7
H13b	7967	36	2492.7	332.4	6.12	975.8	131.2	3.83	391.2	201.4
H13a	8007	35	2404.9	320.7	6.10	870.2	121.6	3.67	378.1	186.9
H13a	7746	40	2294.2	308.5	6.07	832.4	116.7	3.66	362.5	179.3
H13a	7502	45	2188.4	296.7	6.04	797.0	111.9	3.64	347.6	172.0
H13a	7238	52	2081.9	284.7	6.01	760.3	107.1	3.63	332.4	164.5
H13a	6974	60	1977.7	272.8	5.98	724.2	102.3	3.62	317.4	157.1
H13a	6710	69	1875.5	260.9	5.95	688.6	97.5	3.61	302.6	149.8
H13a	6443	81	1775.5	249.2	5.92	653.6	92.8	3.59	287.9	142.5
H13a	6176	95	1677.5	237.5	5.89	619.0	88.2	3.58	273.4	135.4
H13a	5908	112	1581.6	225.9	5.86	585.1	83.6	3.57	259.1	128.3
H13	5949	111	1511.4	215.9	5.84	504.9	75.9	3.38	248.2	116.5
H13	5679	132	1421.7	204.9	5.82	475.9	71.7	3.36	234.6	110.2
H13c	6485	99	1129.3	173.7	5.22	438.6	60.1	3.25	201.5	96.5
H13	5407	159	1333.9	194.0	5.79	447.4	67.6	3.35	221.3	103.9
H13	5134	195	1248.1	183.2	5.76	419.3	63.6	3.34	208.1	97.6
H13	4875	238	1166.1	172.8	5.72	392.7	59.7	3.32	195.6	91.7
H13	4602	297	1083.9	162.1	5.70	365.5	55.7	3.31	182.7	85.6
H13	4327	377	1003.5	151.5	5.67	338.8	51.8	3.29	170.1	79.6
H13	4053	485	924.8	140.9	5.64	312.5	47.9	3.28	157.5	73.6
H13	3776	638	847.9	130.5	5.61	286.7	44.1	3.26	145.2	67.8

Table 2.3.1 Dimensions and Primary Properties -- Steel Sections 1887-1952

Designation	Source Reference Number	Wt. per ft lb	Area	Depth	Web Thickness	Flange Width	Average Flange Thickness	Distance	Distance	Compact Section Criteria		
			A	d	t _w	b _f	t _f	T	k	b/2t _f	h/t _w	F _y "
			in.2	in.	in.	in.	in.	in.	in.	in.		
H13s	1	86.6	25.48	13.00	0.510	12.040	0.818	10.122	1.439	7.36	19.8	-
H13s	1	79.8	23.46	12.88	0.470	12.000	0.755	10.123	1.376	7.95	21.5	-
H13s	1	75.6	22.22	12.88	0.480	11.040	0.760	10.123	1.376	7.27	21.1	-
H13s	1	69.1	20.33	12.75	0.440	11.000	0.697	10.122	1.314	7.89	23.0	-
H13s	1	64.9	19.09	12.75	0.440	10.040	0.702	10.122	1.314	7.15	23.0	-
H13s	1	58.9	17.33	12.63	0.400	10.000	0.639	10.123	1.251	7.82	25.3	-
H13s	1	55.0	16.17	12.63	0.400	9.030	0.644	10.123	1.251	7.01	25.3	-
H13s	1	49.9	14.67	12.50	0.370	9.000	0.582	10.122	1.189	7.73	27.4	-
H13s	1	46.3	13.62	12.50	0.370	8.040	0.587	10.122	1.189	6.85	27.4	-
H13s	1	41.2	12.12	12.38	0.330	8.000	0.524	10.123	1.126	7.63	30.7	-
H12b	1	268.8	79.06	15.00	1.410	14.320	2.244	9.256	2.872	3.19	6.6	-
H12b	1	260.7	76.68	14.88	1.370	14.280	2.181	9.257	2.809	3.27	6.8	-
H12b	1	252.8	74.31	14.75	1.330	14.240	2.119	9.256	2.747	3.36	7.0	-
H12b	1	244.6	71.94	14.63	1.290	14.200	2.056	9.257	2.684	3.45	7.2	-
H12b	1	236.6	69.59	14.50	1.250	14.160	1.994	9.256	2.622	3.55	7.4	-
H12b	1	228.6	67.24	14.38	1.210	14.120	1.931	9.257	2.559	3.66	7.7	-
CB127	9	230.0	67.64	12.00	1.980	14.980	1.677	7.221	2.390	4.47	3.6	-
H12b	1	220.7	64.91	14.25	1.170	14.080	1.869	9.256	2.497	3.77	7.9	-
CB127	9	220.0	64.70	12.00	1.735	14.735	1.677	7.221	2.390	4.39	4.2	-
H12b	1	212.8	62.58	14.13	1.130	14.040	1.806	9.257	2.434	3.89	8.2	-
CB127	9	210.0	61.76	12.00	1.490	14.490	1.677	7.221	2.390	4.32	4.8	-
H12b	1	204.9	60.27	14.00	1.090	14.000	1.744	9.256	2.372	4.01	8.5	-
CB127	9	200.0	58.82	12.00	1.245	14.245	1.677	7.221	2.390	4.25	5.8	-
H12a	1	197.1	57.96	14.00	1.090	13.310	1.747	9.256	2.372	3.81	8.5	-
H12	5	190.0	55.91	14.00	1.090	12.620	1.750	9.256	2.372	3.61	8.5	-
CB127	9	190.0	55.88	12.00	1.000	14.000	1.677	7.221	2.390	4.17	7.2	-
CB125N	11	190.0	55.86	14.38	1.066	12.671	1.736	9.583	2.399	3.65	9.0	-
12WF	6 7 8 12 13	190.0	55.86	14.38	1.060	12.670	1.736	9.583	2.399	3.65	9.0	-
H12	4	190.0	55.62	14.00	1.090	12.620	1.750	9.256	2.372	3.61	8.5	-
H12a	1	189.9	55.87	13.88	1.060	13.280	1.684	9.257	2.309	3.94	8.7	-
H12	5	183.0	53.78	13.88	1.050	12.580	1.688	9.257	2.309	3.73	8.8	-
H12	4	183.0	53.48	13.88	1.050	12.580	1.688	9.257	2.309	3.73	8.8	-
H12a	1	182.4	53.66	13.75	1.020	13.240	1.622	9.256	2.247	4.08	9.1	-
CB126	9	180.0	52.94	12.00	1.492	14.735	1.312	7.951	2.025	5.62	5.3	-
12WF	6 7 12	176.0	51.79	14.12	1.005	12.615	1.606	9.583	2.269	3.93	9.5	-
H12	5	176.0	51.79	13.75	1.020	12.550	1.625	9.256	2.247	3.86	9.1	-
CB125N	11	176.0	51.75	14.12	1.008	12.613	1.606	9.583	2.269	3.93	9.5	-
H12	4	176.0	51.50	13.75	1.020	12.550	1.625	9.256	2.247	3.86	9.1	-
H12a	1	174.9	51.46	13.63	0.980	13.200	1.559	9.257	2.184	4.23	9.4	-
CB126	9	170.0	50.00	12.00	1.247	14.490	1.312	8.051	1.975	5.52	6.5	-
H12	6	169.0	49.72	14.00	0.965	12.575	1.546	9.583	2.209	4.07	9.9	-
CB125N	11	169.0	49.69	14.00	0.969	12.574	1.546	9.583	2.209	4.07	9.9	-
H12	5	169.0	49.68	13.63	0.980	12.510	1.563	9.257	2.184	4.00	9.4	-
H12	4	169.0	49.38	13.63	0.980	12.510	1.563	9.257	2.184	4.00	9.4	-
H12a	1	167.5	49.27	13.50	0.940	13.160	1.497	9.256	2.122	4.40	9.8	-
H12	5	162.0	47.57	13.50	0.940	12.470	1.500	9.256	2.122	4.16	9.8	-
H12	4	162.0	47.28	13.50	0.940	12.470	1.500	9.256	2.122	4.16	9.8	-
12WF	6 7 8 12 13	161.0	47.38	13.88	0.905	12.515	1.486	9.583	2.149	4.21	10.6	-
CB125N	11	161.0	47.33	13.88	0.908	12.513	1.486	9.583	2.149	4.21	10.6	-
H12	2	161.0	47.28	13.50	0.940	12.470	1.500	9.256	2.122	4.16	9.8	-
H12a	1	160.1	47.09	13.38	0.900	13.120	1.434	9.257	2.059	4.57	10.3	-
CB126	9	160.0	47.06	12.00	1.002	14.245	1.312	7.951	2.025	5.43	7.9	-
H12	5	154.5	45.48	13.38	0.900	12.430	1.438	9.257	2.059	4.32	10.3	-
H12	4	154.5	45.19	13.38	0.900	12.430	1.438	9.257	2.059	4.32	10.3	-
CB125N	11	154.0	45.27	13.75	0.876	12.481	1.421	9.583	2.084	4.39	10.9	-
H12	6	154.0	45.27	13.75	0.870	12.480	1.421	9.583	2.084	4.39	11.0	-
H12	2	153.5	45.19	13.38	0.900	12.430	1.438	9.257	2.059	4.32	10.3	-
H12a	1	152.7	44.92	13.25	0.860	13.080	1.372	9.256	1.997	4.77	10.8	-
CB126	9	150.0	44.12	12.00	0.757	14.000	1.312	7.951	2.025	5.34	10.5	-
H12	5	147.5	43.40	13.25	0.860	12.390	1.375	9.256	1.997	4.51	10.8	-
H12	4	147.5	43.10	13.25	0.860	12.390	1.375	9.256	1.997	4.51	10.8	-
12WF	6 7 12	147.0	43.24	13.62	0.840	12.450	1.356	9.583	2.019	4.59	11.4	-
CB125N	11	147.0	43.21	13.62	0.844	12.449	1.356	9.583	2.019	4.59	11.4	-
H12	2	146.5	43.10	13.25	0.860	12.390	1.375	9.256	1.997	4.51	10.8	-
H12a	1	145.4	42.76	13.13	0.820	13.040	1.309	9.257	1.934	4.98	11.3	-
H12	5	140.5	41.32	13.13	0.820	12.350	1.313	9.257	1.934	4.70	11.3	-
H12	4	140.5	41.03	13.13	0.820	12.350	1.313	9.257	1.934	4.70	11.3	-
H12	6	140.0	41.20	13.50	0.800	12.410	1.296	9.583	1.959	4.79	12.0	-
CB125	9	140.0	41.18	12.00	1.376	12.736	1.075	8.525	1.738	5.92	6.2	-
CB125N	11	140.0	41.15	13.50	0.802	12.407	1.296	9.583	1.959	4.79	11.9	-
H12	2	139.5	41.03	13.13	0.820	12.350	1.313	9.257	1.934	4.70	11.3	-
H12a	1	138.1	40.61	13.00	0.780	13.000	1.247	9.256	1.872	5.21	11.9	-
H12c	1	134.5	39.57	12.25	1.400	14.310	0.869	9.256	1.497	8.24	6.6	-
H12	5	133.5	39.26	13.00	0.780	12.310	1.250	9.256	1.872	4.92	11.9	-
H12	4	133.5	38.97	13.00	0.780	12.310	1.250	9.256	1.872	4.92	11.9	-
12WF	6 7 8 12 13	133.0	39.11	13.38	0.755	12.365	1.236	9.583	1.899	5.00	12.7	-

Table 2.3.1 Dimensions and Primary Properties – Steel Sections 1887-1952

Designation	X ₁ ksi	X ₂ x 106 (1/ksi) ²	Elastic Properties						Plastic Modulus	
			Axis x-x			Axis y-y			Z _x in.3	Z _y in.3
			I _x	S _x	r _x	I _y	S _y	r _y		
			in.4	in.3	in.	in.4	in.3	in.		
H13s	3826	618	793.6	122.1	5.58	229.9	38.2	3.00	136.4	58.7
H13s	3545	830	723.5	112.4	5.55	209.5	34.9	2.99	124.9	53.7
H13s	3615	791	674.8	104.8	5.51	164.8	29.9	2.72	117.1	46.0
H13s	3334	1083	611.2	95.9	5.48	149.1	27.1	2.71	106.6	41.7
H13s	3391	1041	565.6	88.7	5.44	114.6	22.8	2.45	99.1	35.2
H13s	3106	1464	508.3	80.5	5.42	102.8	20.6	2.44	89.5	31.7
H13s	3165	1403	466.5	73.9	5.37	76.6	17.0	2.18	82.5	26.2
H13s	2906	1973	417.0	66.7	5.33	68.2	15.2	2.16	74.3	23.4
H13s	2966	1886	379.7	60.8	5.28	49.3	12.3	1.90	68.0	19.0
H13s	2679	2802	334.5	54.1	5.25	43.2	10.8	1.89	60.3	16.7
H12b	10495	13	2777.0	370.3	5.93	1086.2	151.7	3.71	448.8	233.5
H12b	10226	14	2666.2	358.5	5.90	1046.5	146.6	3.69	433.1	225.5
H12b	9961	15	2557.6	346.8	5.87	1007.5	141.5	3.68	417.8	217.6
H12b	9688	17	2451.1	335.2	5.84	969.0	136.5	3.67	402.5	209.8
H12b	9420	19	2346.9	323.7	5.81	931.0	131.5	3.66	387.6	202.2
H12b	9143	21	2244.7	312.3	5.78	893.6	126.6	3.65	372.6	194.5
CB127	11907	8	1461.9	243.7	4.65	945.5	126.2	3.74	296.3	196.6
H12b	8869	24	2144.7	301.1	5.75	856.8	121.6	3.63	358.0	187.0
CB127	11097	11	1426.6	237.8	4.70	898.2	121.9	3.73	287.5	188.6
H12b	8592	27	2046.7	289.8	5.72	820.5	116.9	3.62	343.5	179.5
CB127	10404	13	1391.3	231.9	4.75	852.9	117.7	3.72	278.7	180.9
H12b	8317	30	1950.8	278.7	5.69	784.8	112.1	3.61	329.3	172.2
CB127	9829	16	1356.1	226.0	4.80	809.5	113.7	3.71	269.9	173.5
H12a	8368	30	1862.2	266.0	5.67	676.6	101.7	3.42	314.9	156.3
H12	8408	30	1780.9	254.4	5.64	578.7	91.7	3.22	300.6	141.2
CB127	9368	18	1320.8	220.1	4.86	767.8	109.7	3.71	261.1	166.5
CB125N	7961	37	1891.5	263.1	5.82	589.8	93.1	3.25	309.8	142.5
12WF	7949	37	1892.5	263.2	5.82	589.7	93.1	3.25	309.6	142.4
H12	8422	29	1773.4	253.3	5.65	578.6	91.7	3.23	300.6	141.2
H12a	8103	34	1774.7	255.8	5.64	647.5	97.5	3.40	301.9	149.9
H12	8125	34	1695.4	244.4	5.61	552.4	87.8	3.20	287.7	135.1
H12	8139	34	1687.8	243.3	5.62	552.2	87.8	3.21	287.7	135.1
H12a	7820	39	1686.9	245.4	5.61	617.4	93.3	3.39	288.5	143.3
CB126	8621	29	1218.1	203.0	4.80	702.4	95.3	3.64	239.4	147.6
12WF	7428	48	1712.5	242.6	5.75	538.4	85.4	3.22	283.4	130.5
H12	7862	38	1613.9	234.7	5.58	527.7	84.1	3.19	275.4	129.4
CB125N	7438	48	1710.6	242.3	5.75	538.1	85.3	3.22	283.5	130.5
H12	7876	38	1606.3	233.6	5.59	527.6	84.1	3.20	275.4	129.4
H12a	7538	44	1601.0	235.0	5.58	587.7	89.0	3.38	275.3	136.8
CB126	7864	39	1182.8	197.1	4.86	666.9	92.1	3.65	230.6	141.4
H12	7164	55	1628.5	232.6	5.72	513.3	81.6	3.21	270.8	124.8
CB125N	7174	55	1626.9	232.4	5.72	513.2	81.6	3.21	270.9	124.8
H12	7574	44	1532.0	224.9	5.55	502.0	80.3	3.18	262.8	123.5
H12	7588	44	1524.4	223.8	5.56	502.1	80.3	3.19	262.8	123.5
H12a	7254	51	1516.9	224.7	5.55	558.5	84.9	3.37	262.3	130.4
H12	7288	51	1451.9	215.1	5.52	477.0	76.5	3.17	250.4	117.7
H12	7303	51	1444.3	214.0	5.53	477.0	76.5	3.18	250.4	117.7
12WF	6859	65	1541.8	222.2	5.70	486.2	77.7	3.20	257.4	118.6
CB125N	6869	64	1540.0	221.9	5.70	486.0	77.7	3.20	257.5	118.6
H12	7303	51	1444.3	214.0	5.53	477.0	76.5	3.18	250.4	117.7
H12a	6967	60	1434.6	214.5	5.52	529.8	80.8	3.35	249.5	124.0
CB126	7312	50	1147.5	191.3	4.94	633.0	88.9	3.67	221.8	135.5
H12	7000	60	1373.5	205.4	5.50	452.3	72.8	3.15	238.1	111.9
H12	7015	59	1366.0	204.3	5.50	452.2	72.8	3.16	238.1	111.9
CB125N	6597	75	1455.5	211.7	5.67	461.1	73.9	3.19	244.7	112.8
H12	6582	76	1456.6	211.9	5.67	461.1	73.9	3.19	244.5	112.7
H12	7015	59	1366.0	204.3	5.50	452.2	72.8	3.16	238.1	111.9
H12a	6680	70	1354.2	204.4	5.49	501.5	76.7	3.34	236.8	117.7
CB126	6877	59	1112.3	185.4	5.02	600.4	85.8	3.69	213.0	129.9
H12	6711	70	1296.9	195.8	5.47	428.1	69.1	3.14	226.0	106.2
H12	6729	69	1289.4	194.6	5.47	428.0	69.1	3.15	226.0	106.2
12WF	6313	89	1374.4	201.8	5.64	436.8	70.2	3.18	232.0	107.0
CB125N	6323	89	1372.8	201.6	5.64	436.6	70.1	3.18	232.1	107.0
H12	6729	69	1289.4	194.6	5.47	428.0	69.1	3.15	226.0	106.2
H12a	6390	83	1275.6	194.4	5.46	473.7	72.7	3.33	224.3	111.5
H12	6421	83	1222.1	186.2	5.44	404.2	65.5	3.13	214.1	100.6
H12	6440	82	1214.5	185.0	5.44	404.1	65.4	3.14	214.1	100.6
H12	6041	105	1297.5	192.2	5.61	413.4	66.6	3.17	220.1	101.5
CB125	7628	50	934.8	155.8	4.76	372.4	58.5	3.01	183.0	91.8
CB125N	6049	105	1295.5	191.9	5.61	413.1	66.6	3.17	220.1	101.5
H12	6440	82	1214.5	185.0	5.44	404.1	65.4	3.14	214.1	100.6
H12a	6101	99	1198.8	184.4	5.43	446.4	68.7	3.32	212.0	105.4
H12c	6775	80	941.9	157.0	4.88	412.5	57.7	1.02	180.1	92.3
H12	6128	99	1148.9	176.8	5.41	380.8	61.9	3.11	202.3	95.0
H12	6147	98	1141.3	175.6	5.41	380.7	61.9	3.13	202.3	95.0
12WF	5761	126	1221.2	182.5	5.59	389.9	63.1	3.16	208.1	96.0

Table 2.3.1 Dimensions and Primary Properties -- Steel Sections 1887-1952

Designation	Source Reference Number	Wt. per ft lb	Area	Depth	Web Thickness	Flange Width	Average Flange Thickness	Distance	Distance	Compact Section Criteria		
			A	d	t _w	b _f	t _f	T	k	b/2t _f	h/t _w	F _y "
			in.2	in.	in.	in.	in.	in.	in.	in.		
CB125N	11	133.0	39.10	13.38	0.760	12.365	1.236	9.583	1.899	5.00	12.6	-
H12	12	132.5	38.97	13.00	0.780	12.310	1.250	9.256	1.872	4.92	11.9	-
CB125	9	130.0	38.24	12.00	1.131	12.491	1.075	8.525	1.738	5.81	7.5	-
H12	5	126.5	37.21	12.88	0.740	12.270	1.188	9.257	1.809	5.17	12.5	-
H12	4	126.5	36.94	12.88	0.740	12.270	1.188	9.257	1.809	5.17	12.5	-
CB125N	11	126.0	37.04	13.25	0.726	12.331	1.171	9.583	1.834	5.27	13.2	-
H12	6	126.0	37.04	13.25	0.720	12.330	1.171	9.583	1.834	5.26	13.3	-
H12	12	125.5	36.91	12.88	0.740	12.270	1.188	9.257	1.809	5.17	12.5	-
12WF	6 7 8 12 13	120.0	35.31	13.12	0.710	12.320	1.106	9.583	1.769	5.57	13.5	-
CB125	9	120.0	35.28	12.00	0.885	12.245	1.075	8.525	1.738	5.70	9.6	-
CB125N	11	120.0	35.26	13.12	0.713	12.318	1.106	9.583	1.769	5.57	13.4	-
H12	5	119.5	35.16	12.75	0.700	12.230	1.125	9.256	1.747	5.44	13.2	-
H12	4	119.5	34.87	12.75	0.700	12.230	1.125	9.256	1.747	5.44	13.2	-
H12	1	118.6	34.87	12.75	0.700	12.230	1.125	9.256	1.747	5.44	13.2	-
H12	2	118.5	34.87	12.75	0.700	12.230	1.125	9.256	1.747	5.44	13.2	-
H12	5	113.0	33.25	12.63	0.670	12.200	1.063	9.257	1.684	5.74	13.8	-
H12	6	113.0	33.24	13.00	0.665	12.275	1.046	9.583	1.709	5.87	14.4	-
CB125N	11	113.0	33.21	13.00	0.669	12.274	1.046	9.583	1.709	5.87	14.3	-
H12	4	113.0	32.96	12.63	0.670	12.200	1.063	9.257	1.684	5.74	13.8	-
H12	1	112.1	32.96	16.63	0.670	12.200	1.063	13.257	1.684	5.74	19.8	-
H12	2	112.0	32.96	12.63	0.670	12.200	1.063	9.257	1.684	5.74	13.8	-
CB125	9	110.0	32.34	12.00	0.640	12.000	1.075	8.525	1.738	5.58	13.3	-
H12	5	106.0	31.23	12.50	0.630	12.160	1.000	9.256	1.622	6.08	14.7	-
12WF	6 7 8 12 13	106.0	31.19	12.88	0.620	12.230	0.986	9.583	1.649	6.20	15.5	-
CB125N	11	106.0	31.15	12.88	0.623	12.228	0.986	9.583	1.649	6.20	15.4	-
H12	4	106.0	30.94	12.50	0.630	12.160	1.000	9.256	1.622	6.08	14.7	-
H12	1	105.2	30.94	12.50	0.630	12.160	1.000	9.256	1.622	6.08	14.7	-
H12	2	105.0	30.94	12.50	0.630	12.160	1.000	9.256	1.622	6.08	14.7	-
CB124C	10	102.0	29.99	12.00	0.943	12.490	0.800	9.175	1.413	7.81	9.7	-
CB124	9	100.0	29.41	12.00	1.121	10.613	0.830	9.115	1.443	6.39	8.1	-
H12	5	99.5	29.21	12.38	0.590	12.120	0.938	9.257	1.559	6.46	15.7	-
H12	4	99.5	28.92	12.38	0.590	12.120	0.938	9.257	1.559	6.46	15.7	-
CB125N	11	99.0	29.09	12.75	0.586	12.191	0.921	9.583	1.584	6.62	16.4	-
12WF	6 7 8 12 13	99.0	29.09	12.75	0.580	12.190	0.921	9.583	1.584	6.62	16.5	-
H12	2	98.5	28.92	12.38	0.590	12.120	0.938	9.257	1.559	6.46	15.7	-
H12	1	98.3	28.92	12.38	0.590	12.120	0.938	9.257	1.559	6.46	15.7	-
CB124C	10	95.0	27.93	12.00	0.771	12.318	0.800	9.175	1.413	7.70	11.9	-
H12	5	92.5	27.21	12.25	0.550	12.080	0.875	9.256	1.497	6.90	16.8	-
H12	4	92.5	26.92	12.25	0.550	12.080	0.875	9.256	1.497	6.90	16.8	-
12WF	6 7 8 12 13	92.0	27.06	12.62	0.545	12.155	0.856	9.583	1.519	7.10	17.6	-
CB125N	11	92.0	27.04	12.62	0.549	12.154	0.856	9.583	1.519	7.10	17.5	-
H12	12	91.5	26.92	12.25	0.550	12.080	0.875	9.256	1.497	6.90	16.8	-
CB124	9	91.0	26.76	12.00	0.900	10.392	0.830	9.115	1.443	6.26	10.1	-
CB124C	10	88.0	25.88	12.00	0.600	12.147	0.800	9.275	1.363	7.59	15.5	-
H12	5	85.5	25.21	12.13	0.510	12.040	0.813	9.257	1.434	7.41	18.2	-
H12	4	85.5	24.92	12.13	0.510	12.040	0.813	9.257	1.434	7.41	18.2	-
CB125N	11	85.0	24.98	12.50	0.501	12.106	0.796	9.583	1.459	7.60	19.1	-
12WF	6 7 8 12 13	85.0	24.98	12.50	0.495	12.105	0.796	9.583	1.459	7.60	19.4	-
H12	1	84.7	24.92	12.13	0.510	12.040	0.813	9.257	1.434	7.41	18.2	-
H12	2	84.5	24.92	12.13	0.510	12.040	0.813	9.257	1.434	7.41	18.2	-
CB124	9	83.0	24.41	12.00	0.704	10.196	0.830	9.115	1.443	6.14	12.9	-
CB124C	10	82.0	24.11	12.00	0.453	12.000	0.800	9.175	1.413	7.50	20.3	-
H12	5	79.0	23.23	12.00	0.470	12.000	0.750	9.256	1.372	8.00	19.7	-
CB125N	11	79.0	23.22	12.38	0.476	12.081	0.736	9.583	1.399	8.21	20.1	-
12WF	6 7 8 12 13	79.0	23.22	12.38	0.470	12.080	0.736	9.583	1.399	8.21	20.4	-
H12	4	79.0	22.94	12.00	0.470	12.000	0.750	9.256	1.372	8.00	19.7	-
H12	12	78.0	22.94	12.00	0.470	12.000	0.750	9.256	1.372	8.00	19.7	-
CB124B	10	76.0	22.35	12.00	0.670	12.270	0.608	9.559	1.221	10.09	14.3	-
CB124	9	75.0	22.05	12.00	0.508	10.000	0.830	9.115	1.443	6.02	17.9	-
H12s	1	73.4	21.60	12.00	0.470	11.040	0.755	9.256	1.372	7.31	19.7	-
H12	5	72.5	21.25	11.88	0.430	11.960	0.688	9.257	1.309	8.70	21.5	-
H12	4	72.5	20.96	11.88	0.430	11.960	0.688	9.257	1.309	8.70	21.5	-
CB125N	11	72.0	21.15	12.25	0.436	12.041	0.671	9.583	1.334	8.97	22.0	-
12WF	6 7 8 12 13	72.0	21.16	12.25	0.430	12.040	0.671	9.583	1.334	8.97	22.3	-
H12	2	71.5	20.96	11.88	0.430	11.960	0.688	9.257	1.309	8.70	21.5	-
H12/10	5	70.0	20.59	12.00	0.470	10.120	0.760	9.256	1.372	6.66	19.7	-
CB124B	10	70.0	20.58	12.00	0.523	12.123	0.608	9.559	1.221	9.97	18.3	-
H12/10	3	70.0	20.30	12.00	0.470	10.120	0.760	9.256	1.372	6.66	19.7	-
H12s	1	67.1	19.74	11.88	0.430	11.000	0.692	9.257	1.309	7.95	21.5	-
CB123B	10	66.0	19.41	12.26	0.448	9.073	0.795	9.445	1.408	5.71	21.1	-
H12	5	65.5	19.29	11.75	0.390	11.920	0.625	9.256	1.247	9.54	23.7	-
H12	4	65.5	19.00	11.75	0.390	11.920	0.625	9.256	1.247	9.54	23.7	-
CB124B	10	65.0	19.11	12.00	0.400	12.000	0.608	9.559	1.221	9.87	23.9	-
12WF	6 7 8 12 13	65.0	19.11	12.12	0.390	12.000	0.606	9.583	1.269	9.90	24.6	-
CB125N	11	65.0	19.09	12.12	0.395	12.000	0.606	9.583	1.269	9.90	24.3	-

Table 2.3.1 Dimensions and Primary Properties -- Steel Sections 1887-1952

Designation	X ₁ ksi	X ₂ x 106 (1/ksi) ²	Elastic Properties						Plastic Modulus	
			Axis x-x			Axis y-y			Z _x in.3	Z _y in.3
			I _x in.4	S _x in.3	r _x in.	I _y in.4	S _y in.3	r _y in.		
CB125N	5774	125	1219.9	182.3	5.59	389.9	63.1	3.16	208.2	96.1
H12	6147	98	1141.3	175.6	5.41	380.7	61.9	3.13	202.3	95.0
CB125	6736	77	899.5	149.9	4.85	350.5	56.1	3.03	174.1	87.0
H12	5835	119	1077.4	167.4	5.38	357.7	58.3	3.10	190.7	89.6
H12	5856	118	1069.8	166.2	5.38	357.7	58.3	3.11	190.7	89.6
CB125N	5491	152	1142.0	172.4	5.55	366.3	59.4	3.14	196.0	90.5
H12	5476	153	1143.2	172.6	5.56	366.3	59.4	3.14	195.8	90.4
H12	5853	118	1069.8	166.2	5.38	357.7	58.3	3.11	190.7	89.6
12WF	5236	184	1071.7	163.4	5.51	345.1	56.0	3.13	184.8	85.3
CB125	6028	111	864.1	144.0	4.95	329.6	53.8	3.06	165.3	82.5
CB125N	5246	182	1069.9	163.1	5.51	344.9	56.0	3.13	184.9	85.3
H12	5543	145	1007.5	158.0	5.35	335.1	54.8	3.09	179.2	84.1
H12	5559	143	1000.0	156.9	5.36	335.0	54.8	3.10	179.2	84.1
H12	5559	143	1000.0	156.9	5.36	335.0	54.8	3.10	179.2	84.1
H12	5559	143	1000.0	156.9	5.36	335.0	54.8	3.10	179.2	84.1
H12	5263	178	941.0	149.1	5.32	313.7	51.4	3.07	168.3	79.0
H12	4952	227	1000.4	153.9	5.49	322.8	52.6	3.12	173.3	80.0
CB125N	4962	225	998.8	153.7	5.48	322.7	52.6	3.12	173.4	80.0
H12	5282	175	933.4	147.9	5.33	313.6	51.4	3.08	168.3	79.0
H12	5373	296	933.4	147.9	5.33	313.6	51.4	3.08	236.9	79.4
H12	5282	175	933.4	147.9	5.33	313.6	51.4	3.08	168.3	79.0
CB125	5519	144	828.8	138.1	5.06	309.9	51.6	3.10	156.5	78.4
H12	4968	222	874.3	139.9	5.29	291.8	48.0	3.06	157.2	73.7
12WF	4668	284	930.7	144.5	5.46	300.9	49.2	3.11	161.9	74.8
CB125N	4675	283	929.9	144.3	5.46	300.7	49.2	3.11	161.9	74.8
H12	4991	218	866.8	138.6	5.30	291.7	48.0	3.07	157.2	73.7
H12	4991	218	866.8	138.6	5.30	291.7	48.0	3.07	157.2	73.7
H12	4991	218	866.8	138.6	5.30	291.7	48.0	3.07	157.2	73.7
CB124C	5135	230	721.4	120.2	4.90	260.6	41.7	2.95	137.4	64.7
CB124	6242	121	659.0	109.8	4.73	167.5	31.6	2.39	128.4	50.0
H12	4670	281	809.2	130.8	5.26	270.3	44.6	3.04	146.2	68.5
H12	4689	276	801.7	129.6	5.27	270.1	44.6	3.06	146.2	68.5
CB125N	4387	362	857.3	134.5	5.43	278.3	45.7	3.09	150.2	69.4
12WF	4371	366	858.5	134.7	5.43	278.2	45.7	3.09	150.1	69.3
H12	4689	276	801.7	129.6	5.27	270.1	44.6	3.06	146.2	68.5
H12	4689	276	801.7	129.6	5.27	270.1	44.6	3.06	146.2	68.5
CB124C	4582	337	696.6	116.1	4.99	249.7	40.5	2.99	131.2	62.2
H12	4374	362	745.7	121.7	5.23	249.2	41.3	3.03	135.4	63.4
H12	4394	355	738.1	120.5	5.24	249.2	41.3	3.04	135.4	63.4
12WF	4085	477	788.9	125.0	5.40	256.4	42.2	3.08	138.6	64.0
CB125N	4096	473	787.4	124.8	5.40	256.3	42.2	3.08	138.7	64.0
H12	4394	355	738.1	120.5	5.24	249.2	41.3	3.04	135.4	63.4
CB124	5316	210	627.2	104.5	4.84	155.9	30.0	2.41	120.4	46.9
CB124C	4137	468	672.0	112.0	5.10	239.2	39.4	3.04	125.1	60.0
H12	4073	476	683.6	112.8	5.21	228.5	38.0	3.01	124.7	58.3
H12	4096	465	676.1	111.5	5.21	228.5	37.9	3.03	124.7	58.3
CB125N	3805	626	722.0	115.5	5.38	235.5	38.9	3.07	127.7	59.0
12WF	3790	634	723.3	115.7	5.38	235.5	38.9	3.07	127.5	59.0
H12	4096	465	676.1	111.5	5.21	228.5	37.9	3.03	124.7	58.3
H12	4096	465	676.1	111.5	5.21	228.5	37.9	3.03	124.7	58.3
CB124	4668	322	598.9	99.8	4.95	147.0	28.8	2.45	113.3	44.4
CB124C	3893	552	650.8	108.5	5.20	230.5	38.4	3.09	119.8	58.1
H12	3774	639	623.1	103.9	5.18	208.2	34.7	2.99	114.2	53.3
CB125N	3552	823	661.9	106.9	5.34	216.4	35.8	3.05	117.7	54.3
12WF	3536	835	663.0	107.1	5.34	216.4	35.8	3.05	117.5	54.3
H12	3798	623	615.6	102.6	5.18	208.1	34.7	3.01	114.2	53.3
H12	3798	623	615.6	102.6	5.18	208.1	34.7	3.01	114.2	53.3
CB124B	3652	855	560.2	93.4	5.01	187.5	30.6	2.90	104.5	47.0
CB124	4197	443	570.7	95.1	5.09	138.5	27.7	2.51	106.3	42.2
H12s	3851	602	572.8	95.5	5.15	163.7	29.7	2.75	106.6	45.6
H12	3476	878	564.1	95.0	5.15	188.2	31.5	2.98	103.8	48.4
H12	3500	854	556.6	93.7	5.15	188.2	31.5	3.00	103.8	48.4
CB125N	3255	1156	596.2	97.3	5.31	195.3	32.4	3.04	106.5	49.2
12WF	3240	1174	597.4	97.5	5.31	195.3	32.4	3.04	106.3	49.1
H12	3500	854	556.6	93.7	5.15	188.2	31.5	3.00	103.8	48.4
H12/10	3882	599	538.8	89.8	5.12	127.3	25.2	2.49	99.3	38.7
CB124B	3239	1269	539.0	89.8	5.12	180.7	29.8	2.96	99.2	45.4
H12/10	3911	582	531.3	88.5	5.12	127.3	25.2	2.50	99.3	38.7
H12s	3546	828	518.0	87.3	5.12	148.0	26.9	2.74	96.9	41.4
CB123B	3876	610	525.7	85.8	5.20	99.1	21.8	2.26	95.4	33.3
H12	3178	1244	506.6	86.2	5.12	168.6	28.3	2.96	93.6	43.5
H12	3203	1206	499.0	84.9	5.13	168.6	28.3	2.98	93.6	43.5
CB124B	2981	1627	521.3	86.9	5.22	175.2	29.2	3.03	94.7	44.2
12WF	2942	1709	533.4	88.0	5.28	174.6	29.1	3.02	95.3	44.0
CB125N	2955	1684	532.0	87.8	5.28	174.6	29.1	3.02	95.5	44.1

Table 2.3.1 Dimensions and Primary Properties -- Steel Sections 1887-1952

Designation	Source Reference Number	Wt. per ft lb	Area	Depth	Web Thickness	Flange Width	Average Flange Thickness	Distance	Distance	Compact Section Criteria		
			A	d	t _w	b _f	t _f	T	k	b _f /2t _f	h/t _w	F _y "
			in.2	in.	in.	in.	in.	in.	in.	in.		
H12	2	64.5	19.00	11.75	0.390	11.920	0.625	9.256	1.247	9.54	23.7	-
H12/10	5	64.0	18.85	11.88	0.430	10.080	0.697	9.257	1.309	7.23	21.5	-
H12a	6	64.0	18.84	12.31	0.405	10.065	0.701	9.583	1.364	7.18	23.7	-
12WF	7 12	64.0	18.83	12.31	0.405	10.060	0.701	9.583	1.364	7.18	23.7	-
CB124N	11	64.0	18.81	12.31	0.409	10.060	0.701	9.583	1.364	7.18	23.4	-
H12/10	3	64.0	18.56	11.88	0.430	10.080	0.697	9.257	1.309	7.23	21.5	-
H12s	1	63.3	18.61	11.88	0.440	10.040	0.697	9.257	1.309	7.20	21.0	-
CB123B	10	60.0	17.65	12.12	0.409	9.034	0.724	9.445	1.337	6.24	23.1	-
H12/10	5	58.0	17.12	11.75	0.390	10.040	0.635	9.256	1.247	7.91	23.7	-
H12a	6	58.0	17.08	12.19	0.360	10.020	0.641	9.583	1.304	7.82	26.6	-
12WF	7 8 12 13	58.0	17.06	12.19	0.359	10.014	0.641	9.583	1.304	7.81	26.7	-
CB124N	11	58.0	17.04	12.19	0.363	10.014	0.641	9.583	1.304	7.81	26.4	-
H12/10	3	58.0	16.83	11.75	0.390	10.040	0.635	9.256	1.247	7.91	23.7	-
H12s	1	57.4	16.89	11.75	0.400	10.000	0.635	9.256	1.247	7.87	23.1	-
H12s	1	55.6	15.75	11.75	0.400	9.040	0.640	9.256	1.247	7.07	23.1	-
H12/8	5	55.0	16.27	11.88	0.430	8.120	0.707	9.257	1.309	5.75	21.5	-
CB123B	10	55.0	16.17	12.00	0.375	9.000	0.665	9.445	1.278	6.77	25.2	-
H12/8	3	55.0	15.98	11.88	0.430	8.120	0.707	9.257	1.309	5.75	21.5	-
12WF	7 8 12 13	53.0	15.59	12.06	0.345	10.000	0.576	9.583	1.239	8.68	27.8	-
CB124N	11	53.0	15.57	12.06	0.349	10.000	0.576	9.583	1.239	8.68	27.5	-
H12a	6	53.0	15.54	12.06	0.340	10.000	0.576	9.583	1.239	8.68	28.2	-
H12/10	5	52.5	15.40	11.63	0.350	10.000	0.572	9.257	1.184	8.74	26.4	-
H12/10	3	52.5	15.11	11.63	0.350	10.000	0.572	9.257	1.184	8.74	26.4	-
H12/8	5	50.5	14.79	11.75	0.390	8.080	0.645	9.256	1.247	6.27	23.7	-
H12/8	3	50.5	14.49	11.75	0.390	8.080	0.645	9.256	1.247	6.27	23.7	-
12WF	7 8 12 13	50.0	14.71	12.19	0.371	8.077	0.641	9.583	1.304	6.30	25.8	-
H12b	6	50.0	14.70	12.19	0.370	8.075	0.641	9.583	1.304	6.30	25.9	-
CB123	9	50.0	14.69	12.26	0.361	8.071	0.655	9.823	1.218	6.16	27.2	-
CB123N	11	50.0	14.69	12.19	0.375	8.077	0.641	9.583	1.304	6.30	25.6	-
H12s	1	48.1	14.16	11.63	0.360	9.000	0.577	9.257	1.184	7.80	25.7	-
H12/8	5	45.5	13.31	11.63	0.350	8.040	0.582	9.257	1.184	6.91	26.4	-
H12/8	3	45.5	13.02	11.63	0.350	8.040	0.582	9.257	1.184	6.91	26.4	-
12WF	7 8 12 13	45.0	13.24	12.06	0.336	8.042	0.576	9.583	1.239	6.98	28.5	-
H12b	6	45.0	13.23	12.06	0.335	8.040	0.576	9.583	1.239	6.98	28.6	-
H12s	1	45.0	13.23	11.63	0.370	8.040	0.582	9.257	1.184	6.91	25.0	-
CB123	9	45.0	13.23	12.13	0.326	8.036	0.591	9.823	1.154	6.80	30.1	-
CB123N	11	45.0	13.21	12.06	0.340	8.042	0.576	9.583	1.239	6.98	28.2	-
H12/8	5	40.5	11.85	11.50	0.310	8.000	0.520	9.256	1.122	7.70	29.9	-
H12/8	3	40.5	11.55	11.50	0.310	8.000	0.520	9.256	1.122	7.70	29.9	-
H12b	6	40.0	11.78	11.94	0.295	8.000	0.516	9.583	1.179	7.75	32.5	61
12WF	7 8 12 13	40.0	11.77	11.94	0.294	8.000	0.516	9.583	1.179	7.75	32.6	61
CB123	9	40.0	11.76	12.00	0.290	8.000	0.526	9.823	1.089	7.60	33.9	56
H12s	1	40.0	11.76	11.50	0.330	8.000	0.520	9.256	1.122	7.70	28.0	-
CB123N	11	40.0	11.75	11.94	0.298	8.000	0.516	9.583	1.179	7.75	32.2	62
H11a	1	175.8	51.70	13.00	1.060	12.320	1.684	8.475	2.262	3.66	8.0	-
H11a	1	168.8	49.65	12.88	1.020	12.280	1.622	8.474	2.200	3.79	8.3	-
H11a	1	161.9	47.60	12.75	0.980	12.240	1.559	8.475	2.137	3.93	8.6	-
H11a	1	154.9	45.57	12.63	0.940	12.200	1.497	8.474	2.075	4.08	9.0	-
H11a	1	148.1	43.54	12.50	0.900	12.160	1.434	8.475	2.012	4.24	9.4	-
H11a	1	141.2	41.53	12.38	0.860	12.120	1.372	8.474	1.950	4.42	9.9	-
H11a	1	134.4	39.52	12.25	0.820	12.080	1.309	8.475	1.887	4.61	10.3	-
H11a	1	127.6	37.53	12.13	0.780	12.040	1.247	8.474	1.825	4.83	10.9	-
H11a	1	120.9	35.54	12.00	0.740	12.000	1.184	8.475	1.762	5.07	11.5	-
H11	1	115.5	33.98	12.00	0.740	11.310	1.188	8.475	1.762	4.76	11.5	-
H11	1	109.1	32.10	11.88	0.700	11.270	1.125	8.474	1.700	5.01	12.1	-
H11	1	103.1	30.33	11.75	0.670	11.240	1.063	8.475	1.637	5.29	12.6	-
H11	1	96.8	28.46	11.63	0.630	11.200	1.000	8.474	1.575	5.60	13.5	-
H11	1	90.5	26.60	11.50	0.590	11.160	0.938	8.475	1.512	5.95	14.4	-
H11	1	84.2	24.75	11.38	0.550	11.120	0.875	8.474	1.450	6.35	15.4	-
H11	1	77.9	22.91	11.25	0.510	11.080	0.813	8.475	1.387	6.82	16.6	-
H11	1	71.7	21.08	11.13	0.470	11.040	0.741	8.474	1.325	7.45	18.0	-
H11	1	65.5	19.26	11.00	0.430	11.000	0.688	8.475	1.262	8.00	19.7	-
H11s	1	61.3	18.02	11.00	0.430	11.030	0.692	8.475	1.262	7.97	19.7	-
H11s	1	55.9	16.44	10.88	0.400	10.000	0.630	8.474	1.200	7.94	21.2	-
H11s	1	52.1	15.32	10.88	0.400	9.040	0.635	8.474	1.200	7.12	21.2	-
H11s	1	46.8	13.76	10.75	0.360	9.000	0.572	8.475	1.137	7.87	23.5	-
H11s	1	43.3	12.73	10.75	0.360	8.040	0.577	8.475	1.137	6.97	23.5	-
H11s	1	38.4	11.30	10.63	0.320	8.000	0.515	8.474	1.075	7.77	26.5	-
H10/12	6	246.0	72.30	13.00	1.220	14.570	2.107	7.693	2.654	3.46	6.3	-
H10/12	6	238.0	70.04	12.88	1.180	14.530	2.047	7.688	2.594	3.55	6.5	-
H10/12	6	230.0	67.77	12.75	1.150	14.500	1.982	7.693	2.529	3.66	6.7	-
H10/12	6	222.0	65.38	12.63	1.110	14.460	1.917	7.698	2.464	3.77	6.9	-
H10/12	6	215.0	63.27	12.50	1.080	14.430	1.857	7.693	2.404	3.89	7.1	-
H10/12	6	208.0	61.17	12.38	1.050	14.400	1.797	7.688	2.344	4.01	7.3	-
H10/12	6	200.0	58.80	12.25	1.010	14.360	1.732	7.693	2.279	4.15	7.6	-

Table 2.3.1 Dimensions and Primary Properties -- Steel Sections 1887-1952

Designation	X ₁ ksi	X ₂ x 106 (1/ksi) ²	Elastic Properties						Plastic Modulus	
			Axis x-x			Axis y-y			Z _x in.3	Z _y in.3
			I _x	S _x	r _x	I _y	S _y	r _y		
			in.4	in.3	in.	in.4	in.3	in.		
H12	3203	1206	499.0	84.9	5.13	168.6	28.3	2.98	93.6	43.5
H12/10	3578	821	488.2	82.2	5.09	115.1	22.8	2.47	90.3	35.1
H12a	3364	1036	528.6	85.9	5.30	119.2	23.7	2.52	94.0	36.0
12WF	3367	1035	528.3	85.8	5.29	119.0	23.7	2.51	93.9	35.9
CB124N	3375	1025	527.5	85.7	5.30	119.0	23.7	2.52	94.0	35.9
H12/10	3608	795	480.6	80.9	5.09	115.1	22.8	2.49	90.3	35.1
H12s	3629	783	480.0	80.8	5.08	113.8	22.7	2.47	90.3	34.9
CB123B	3549	860	472.0	77.9	5.17	89.0	19.7	2.25	86.2	30.0
H12/10	3273	1158	438.8	74.7	5.06	103.2	20.6	2.45	81.5	31.6
H12a	3072	1463	476.5	78.2	5.28	107.5	21.5	2.51	84.9	32.5
12WF	3072	1463	476.1	78.1	5.28	107.4	21.4	2.51	84.8	32.5
CB124N	3080	1448	475.3	78.0	5.28	107.4	21.4	2.51	84.9	32.5
H12/10	3303	1118	431.3	73.4	5.06	103.2	20.5	2.48	81.5	31.6
H12s	3329	1094	430.8	73.3	5.05	102.0	20.4	2.46	81.6	31.4
H12s	3388	1051	395.4	67.3	5.01	76.3	16.9	2.20	75.2	26.0
H12/8	3709	762	406.9	68.5	5.00	61.5	15.2	1.94	75.8	23.4
CB123B	3271	1178	428.4	71.4	5.15	80.9	18.0	2.24	78.5	27.3
H12/8	3741	735	399.3	67.3	5.00	61.5	15.2	1.96	75.8	23.4
12WF	2816	2087	426.2	70.7	5.23	96.1	19.2	2.48	76.4	29.1
CB124N	2829	2057	425.4	70.5	5.23	96.1	19.2	2.48	76.5	29.1
H12a	2808	2105	425.7	70.6	5.23	96.1	19.2	2.49	76.3	29.1
H12/10	2972	1685	390.7	67.2	5.04	91.5	18.3	2.44	72.8	28.2
H12/10	3002	1621	383.2	65.9	5.04	91.5	18.3	2.46	72.8	28.2
H12/8	3401	1064	366.1	62.3	4.98	55.1	13.6	1.93	68.5	21.1
H12/8	3438	1020	358.5	61.0	4.97	55.1	13.6	1.95	68.5	21.1
12WF	3175	1389	394.5	64.7	5.18	56.4	14.0	1.96	70.8	21.3
H12b	3172	1393	394.3	64.7	5.18	56.3	14.0	1.96	70.8	21.3
CB123	3145	1422	400.5	65.4	5.22	57.5	14.2	1.98	72.2	21.7
CB123N	3190	1368	393.0	64.5	5.17	56.4	14.0	1.96	70.9	21.3
H12s	3082	1518	351.6	60.5	4.98	67.6	15.0	2.19	67.2	23.2
H12/8	3089	1545	326.4	56.1	4.95	48.9	12.2	1.92	61.2	18.7
H12/8	3127	1474	318.8	54.8	4.95	48.8	12.1	1.94	61.2	18.7
12WF	2877	2040	350.8	58.2	5.15	50.0	12.4	1.94	63.2	18.9
H12b	2879	2039	350.6	58.1	5.15	50.0	12.4	1.94	63.1	18.9
H12s	3172	1417	320.8	55.2	4.92	48.9	12.2	1.92	61.8	18.8
CB123	2857	2073	356.9	58.8	5.19	51.2	12.7	1.97	64.6	19.4
CB123N	2896	1998	349.3	57.9	5.14	50.0	12.4	1.95	63.3	18.9
H12/8	2783	2312	287.7	50.0	4.93	42.8	10.7	1.90	54.1	16.5
H12/8	2821	2193	280.1	48.7	4.92	42.8	10.7	1.92	54.1	16.5
H12b	2586	3068	310.2	52.0	5.13	44.1	11.0	1.93	55.9	16.7
12WF	2588	3065	310.1	51.9	5.13	44.1	11.0	1.94	55.9	16.7
CB123	2556	3195	313.7	52.3	5.17	44.9	11.2	1.95	57.0	17.1
H12s	2865	2102	282.1	49.1	4.90	42.8	10.7	1.91	54.7	16.5
CB123N	2603	3007	308.6	51.7	5.13	44.1	11.0	1.94	56.0	16.8
H11a	8779	25	1417.0	218.0	5.24	517.9	84.1	3.17	259.3	129.3
H11a	8477	28	1345.4	209.0	5.21	493.4	80.4	3.15	247.7	123.6
H11a	8141	33	1275.5	200.8	5.18	469.4	76.7	3.14	236.3	117.9
H11a	7866	38	1207.2	191.2	5.15	445.8	73.1	3.13	225.0	112.3
H11a	7559	44	1140.5	182.4	5.12	422.6	69.5	3.12	213.8	106.8
H11a	7241	51	1075.5	173.9	5.09	399.8	65.9	3.10	202.8	101.3
H11a	6933	61	1011.9	165.2	5.06	377.4	62.5	3.09	192.0	95.9
H11a	6619	72	949.9	156.7	5.03	355.4	59.0	3.08	181.3	90.6
H11a	6305	87	889.4	148.2	5.00	333.5	55.6	3.06	170.8	85.4
H11	6356	86	843.1	140.5	4.98	280.7	49.6	2.87	162.3	76.3
H11	6041	104	787.2	132.5	4.95	262.8	46.6	2.86	152.5	71.6
H11	5738	127	734.0	124.9	4.92	245.9	43.7	2.85	143.1	67.2
H11	5417	159	680.8	117.1	4.89	228.6	40.8	2.83	133.6	62.7
H11	5092	201	628.9	109.4	4.86	211.6	37.9	2.82	124.2	58.2
H11	4770	258	578.4	101.7	4.83	194.9	35.1	2.81	114.9	53.8
H11	4444	339	529.2	94.1	4.81	178.6	32.2	2.79	105.8	49.5
H11	4062	482	481.2	86.5	4.78	162.6	29.5	2.78	95.9	44.5
H11	3796	623	434.6	79.0	4.75	147.0	26.7	2.76	87.9	41.1
H11s	4010	513	401.2	73.0	4.72	112.6	22.4	2.50	88.6	41.6
H11s	3549	834	360.5	66.3	4.68	101.2	20.2	2.47	73.8	31.1
H11s	3612	801	330.7	60.8	4.65	75.7	16.7	2.22	68.0	25.8
H11s	3280	1164	293.5	54.6	4.62	67.0	14.9	2.21	60.7	22.9
H11s	3352	1106	266.8	49.6	4.58	48.4	12.0	1.95	55.5	18.6
H11s	3013	1667	234.1	44.1	4.55	42.4	10.6	1.94	49.0	16.3
H10/12	11317	9	1916.1	294.8	5.15	1071.6	147.1	3.85	357.9	224.9
H10/12	11019	10	1835.8	285.1	5.12	1031.9	142.0	3.84	344.7	217.1
H10/12	10717	11	1753.1	275.0	5.09	992.4	136.9	3.83	331.6	209.2
H10/12	10397	12	1670.5	264.7	5.05	951.3	131.6	3.81	318.2	201.1
H10/12	10105	14	1597.2	255.6	5.02	915.2	126.9	3.80	306.0	193.9
H10/12	9818	15	1525.5	246.4	4.99	879.6	122.2	3.79	293.9	186.7
H10/12	9486	17	1448.4	236.5	4.96	840.0	117.0	3.78	281.0	178.8

Table 2.3.1 Dimensions and Primary Properties -- Steel Sections 1887-1952

Designation	Source Reference Number	Wt. per ft lb	Area	Depth	Web Thickness	Flange Width	Average Flange Thickness	Distance	Distance	Compact Section Criteria		
			A	d	t _w	b _f	t _f	T	k	b _f /2t _f	h/t _w	F _y "
			in.2	in.	in.	in.	in.	in.	in.	in.		
H10/12	6	192.0	56.45	12.13	0.970	14.320	1.667	7.698	2.214	4.30	7.9	-
H10/12	6	185.0	54.37	12.00	0.940	14.290	1.607	7.693	2.154	4.45	8.2	-
H10/12	6	177.0	52.18	11.88	0.900	14.250	1.547	7.688	2.094	4.61	8.5	-
H10/12	6	170.0	49.98	11.75	0.870	14.220	1.482	7.693	2.029	4.80	8.8	-
H10/12	6	162.0	47.78	11.63	0.840	14.190	1.417	7.698	1.964	5.01	9.2	-
H10a	1	155.2	45.64	12.00	1.020	11.320	1.622	7.693	2.154	3.49	7.5	-
H10/12	6	155.0	45.62	11.50	0.800	14.150	1.357	7.693	1.904	5.22	9.6	-
H10a	1	148.8	43.75	11.88	0.980	11.280	1.560	7.692	2.092	3.62	7.8	-
H10/12	6	148.0	43.46	11.38	0.760	14.110	1.297	7.688	1.844	5.44	10.1	-
H10a	1	142.4	41.87	11.75	0.940	11.240	1.497	7.693	2.029	3.76	8.2	-
H10/12	6	140.0	41.29	11.25	0.730	14.080	1.232	7.693	1.779	5.72	10.5	-
CB105	10	140.0	41.17	10.00	1.777	13.177	1.016	6.643	1.679	6.48	3.7	-
H10	5 6	136.5	40.08	11.75	0.940	10.550	1.500	7.693	2.029	3.52	8.2	-
H10	4	136.5	39.88	11.75	0.940	10.550	1.500	7.693	2.029	3.52	8.2	-
10WF	7 8 13	136.0	40.03	11.88	0.915	10.575	1.498	7.759	2.061	3.53	8.5	-
CB103N	12	136.0	40.01	11.88	0.915	10.575	1.498	7.659	2.111	3.53	8.4	-
H10a	1	136.0	40.00	11.63	0.900	11.200	1.435	7.692	1.967	3.90	8.5	-
H10/12	6	133.0	39.02	11.13	0.690	14.040	1.167	7.698	1.714	6.02	11.2	-
CB105	10	132.0	38.81	10.00	1.541	12.941	1.016	6.643	1.679	6.37	4.3	-
H10	5 6	130.0	38.30	11.63	0.900	10.510	1.438	7.692	1.967	3.66	8.5	-
H10	7	130.0	38.24	11.75	0.880	10.540	1.433	7.759	1.996	3.68	8.8	-
CB103N	12	130.0	38.23	11.75	0.880	10.540	1.433	7.659	2.046	3.68	8.7	-
H10	4	130.0	38.09	11.63	0.900	10.510	1.438	7.692	1.967	3.66	8.5	-
H10a	1	129.7	38.14	11.50	0.860	11.160	1.372	7.693	1.904	4.07	8.9	-
H10/12	6	125.0	36.89	11.00	0.650	14.000	1.107	7.693	1.654	6.33	11.8	-
H10	5 6	124.0	36.52	11.50	0.860	10.470	1.375	7.693	1.904	3.81	8.9	-
10WF	7 8 13	124.0	36.46	11.62	0.845	10.505	1.368	7.759	1.931	3.84	9.2	-
CB105	10	124.0	36.46	10.00	1.306	12.706	1.016	6.643	1.679	6.25	5.1	-
CB103N	12	124.0	36.45	11.62	0.845	10.505	1.368	7.659	1.981	3.84	9.1	-
H10	4	124.0	36.32	11.50	0.860	10.470	1.375	7.693	1.904	3.81	8.9	-
H10	2	123.5	36.32	11.50	0.860	10.470	1.375	7.693	1.904	3.81	8.9	-
H10a	1	123.4	36.29	11.38	0.820	11.120	1.310	7.692	1.842	4.25	9.4	-
H10	5 6	118.0	34.76	11.38	0.820	10.430	1.313	7.692	1.842	3.97	9.4	-
CB103N	12	118.0	34.68	11.50	0.801	10.461	1.308	7.659	1.921	4.00	9.6	-
H10	7	118.0	34.69	11.50	0.800	10.460	1.308	7.759	1.871	4.00	9.7	-
H10	4	118.0	34.55	11.38	0.820	10.430	1.313	7.692	1.842	3.97	9.4	-
H10	2	117.5	34.55	11.38	0.820	10.430	1.313	7.692	1.842	3.97	9.4	-
H10a	1	117.1	34.45	11.25	0.780	11.080	1.247	7.693	1.779	4.44	9.9	-
CB105	10	116.0	34.11	10.00	1.071	12.471	1.016	6.643	1.679	6.14	6.2	-
H10/12	6	113.0	33.25	11.00	0.650	12.260	1.115	7.693	1.654	5.50	11.8	-
H10	5 6	112.0	33.00	11.25	0.780	10.390	1.250	7.693	1.779	4.16	9.9	-
CB103N	12	112.0	32.92	11.38	0.756	10.416	1.248	7.659	1.861	4.17	10.1	-
10WF	7 8 9 13 14	112.0	32.92	11.38	0.755	10.415	1.248	7.759	1.811	4.17	10.3	-
H10	4	112.0	32.80	11.25	0.780	10.390	1.250	7.693	1.779	4.16	9.9	-
H10	2	111.5	32.80	11.25	0.780	10.390	1.250	7.693	1.779	4.16	9.9	-
H10a	1	110.9	32.62	11.13	0.740	11.040	1.185	7.692	1.717	4.66	10.4	-
CB105	10	108.0	31.76	10.00	0.836	12.236	1.016	6.643	1.679	6.02	7.9	-
H10/12	6	107.0	31.45	10.88	0.620	12.230	1.055	7.688	1.594	5.80	12.4	-
H10	5 6	106.5	31.26	11.13	0.740	10.350	1.188	7.692	1.717	4.36	10.4	-
H10	4	106.5	31.06	11.13	0.740	10.350	1.188	7.692	1.717	4.36	10.4	-
H10	7	106.0	31.17	11.25	0.720	10.380	1.183	7.759	1.746	4.39	10.8	-
CB103N	12	106.0	31.16	11.25	0.720	10.380	1.183	7.659	1.796	4.39	10.6	-
H10	2	105.5	31.06	11.13	0.740	10.350	1.188	7.692	1.717	4.36	10.4	-
H10a	1	104.7	30.80	11.00	0.700	11.000	1.121	7.697	1.652	4.91	11.0	-
H10	5 6	100.5	29.53	11.00	0.700	10.310	1.125	7.693	1.654	4.58	11.0	-
H10	4	100.5	29.32	11.00	0.700	10.310	1.125	7.693	1.654	4.58	11.0	-
H10/12	6	100.0	29.54	10.75	0.590	12.200	0.990	7.693	1.529	6.16	13.0	-
10WF	7 8 9 13 14	100.0	29.43	11.12	0.685	10.345	1.118	7.759	1.681	4.63	11.3	-
CB103N	12	100.0	29.42	11.12	0.685	10.345	1.118	7.659	1.731	4.63	11.2	-
CB105	10	100.0	29.40	10.00	0.600	12.000	1.016	6.643	1.679	5.91	11.1	-
H10	1	99.7	29.32	11.00	0.700	10.310	1.125	7.693	1.654	4.58	11.0	-
H10	2	99.5	29.32	11.00	0.700	10.310	1.125	7.693	1.654	4.58	11.0	-
CB103N	12	95.0	27.92	11.00	0.662	10.322	1.058	7.659	1.671	4.88	11.6	-
H10	7	95.0	27.92	11.00	0.660	10.320	1.058	7.759	1.621	4.88	11.8	-
H10	5 6	95.0	27.91	10.88	0.670	10.280	1.063	7.692	1.592	4.84	11.5	-
H10	4	95.0	27.71	10.88	0.670	10.280	1.063	7.692	1.592	4.84	11.5	-
H10	1	94.2	27.71	10.88	0.670	10.280	1.063	7.692	1.592	4.84	11.5	-
H10	2	94.0	27.71	10.88	0.670	10.280	1.063	7.692	1.592	4.84	11.5	-
H10/12	6	94.0	27.63	10.63	0.560	12.170	0.925	7.698	1.464	6.58	13.7	-
CB104	10	92.0	27.06	10.00	1.162	10.647	0.805	7.265	1.368	6.61	6.3	-
H10	5 6	89.0	26.20	10.75	0.630	10.240	1.000	7.693	1.529	5.12	12.2	-
10WF	7 8 9 13 14	89.0	26.19	10.88	0.615	10.275	0.998	7.759	1.561	5.15	12.6	-
CB103N	12	89.0	26.17	10.88	0.615	10.275	0.998	7.659	1.611	5.15	12.5	-
H10	4	89.0	25.99	10.75	0.630	10.240	1.000	7.693	1.529	5.12	12.2	-
H10	2	88.5	25.99	10.75	0.630	10.240	1.000	7.693	1.529	5.12	12.2	-
H10	1	88.4	25.99	10.75	0.630	10.240	1.000	7.693	1.529	5.12	12.2	-

Table 2.3.1 Dimensions and Primary Properties -- Steel Sections 1887-1952

Designation	X ₁ ksi	X ₂ x 106 (1/ksi) ²	Elastic Properties						Plastic Modulus	
			Axis x-x			Axis y-y			Z _x	Z _y
			I _x in.4	S _x in.3	r _x in.	I _y in.4	S _y in.3	r _y in.	in.3	in.3
H10/12	9156	20	1373.2	226.6	4.93	801.1	111.9	3.77	268.3	171.0
H10/12	8860	22	1306.3	217.7	4.90	766.8	107.3	3.76	256.7	164.0
H10/12	8544	26	1239.6	208.7	4.87	731.3	102.6	3.74	244.9	156.8
H10/12	8222	30	1170.9	199.3	4.84	695.5	97.8	3.73	233.1	149.5
H10/12	7897	35	1103.9	190.0	4.81	660.0	93.0	3.72	221.4	142.2
H10a	9251	20	1053.6	175.6	4.80	387.2	68.4	2.91	210.0	105.3
H10/12	7577	41	1042.0	181.2	4.78	626.0	88.5	3.70	210.1	135.2
H10a	8925	23	997.6	168.0	4.78	368.0	65.3	2.90	200.2	100.4
H10/12	7253	48	981.5	172.5	4.75	592.6	84.0	3.69	199.0	128.4
H10a	8589	27	943.0	160.5	4.75	349.3	62.1	2.89	190.5	95.6
H10/12	6924	57	919.2	163.4	4.72	558.5	79.3	3.68	187.8	121.3
CB105	10785	13	623.2	124.6	3.89	391.4	59.4	3.08	148.5	94.5
H10	8639	27	893.3	152.1	4.72	290.0	55.0	2.69	180.2	84.7
H10	8658	27	889.7	151.4	4.72	289.9	55.0	2.70	180.2	84.7
10WF	8382	30	917.2	154.4	4.79	295.9	56.0	2.72	182.5	85.6
CB103N	8410	30	916.9	154.4	4.79	295.9	56.0	2.72	182.5	85.6
H10a	8256	31	889.8	153.1	4.72	330.8	59.1	2.88	181.0	90.8
H10/12	6576	70	857.4	154.2	4.69	523.7	74.6	3.66	176.4	114.0
CB105	9559	20	603.5	120.7	3.94	369.6	57.1	3.09	142.6	89.8
H10	8308	31	843.0	145.0	4.69	274.5	52.2	2.68	171.1	80.4
H10	8053	35	864.4	147.1	4.75	280.2	53.2	2.71	173.2	81.3
CB103N	8082	35	864.2	147.1	4.75	280.2	53.2	2.71	173.2	81.3
H10	8320	31	839.4	144.4	4.69	274.5	52.2	2.68	171.1	80.4
H10a	7918	37	838.0	145.7	4.69	312.7	56.0	2.86	171.5	86.1
H10/12	6247	84	801.4	145.7	4.66	491.7	70.2	3.65	165.8	107.4
H10	7965	36	794.0	138.1	4.66	259.4	49.5	2.66	162.2	76.2
10WF	7720	41	813.1	139.9	4.72	264.8	50.4	2.69	164.0	77.1
CB105	8471	31	583.9	116.8	4.00	349.0	54.9	3.09	136.7	85.4
CB103N	7749	41	812.9	139.9	4.72	264.8	50.4	2.70	164.0	77.1
H10	7978	36	790.4	137.5	4.67	259.3	49.5	2.67	162.2	76.2
H10	7978	36	790.4	137.5	4.67	259.3	49.5	2.67	162.2	76.2
H10a	7583	43	787.4	138.4	4.66	295.0	53.1	2.85	162.3	81.5
H10	7627	43	746.3	131.2	4.63	244.5	46.9	2.65	153.4	72.1
CB103N	7413	48	765.2	133.1	4.70	250.0	47.8	2.68	155.3	73.0
H10	7382	49	765.3	133.1	4.70	249.9	47.8	2.68	155.2	73.0
H10	7638	43	742.7	130.6	4.64	244.4	46.9	2.66	153.4	72.1
H10	7638	43	742.7	130.6	4.64	244.4	46.9	2.66	153.4	72.1
H10a	7237	52	738.2	131.2	4.63	277.6	50.1	2.84	153.1	76.9
CB105	7554	46	564.3	112.9	4.07	329.4	52.8	3.11	130.8	81.3
H10/12	6350	82	710.8	129.2	4.62	334.3	54.5	3.17	147.6	83.4
H10	7282	51	699.9	124.4	4.60	229.9	44.3	2.64	144.8	68.1
CB103N	7076	57	718.6	126.3	4.67	235.4	45.2	2.67	146.6	69.0
10WF	7046	58	718.7	126.3	4.67	235.4	45.2	2.67	146.6	69.0
H10	7295	51	696.2	123.8	4.61	229.9	44.3	2.65	144.8	68.1
H10	7295	51	696.2	123.8	4.61	229.9	44.3	2.65	144.8	68.1
H10a	6896	62	690.3	124.1	4.60	260.5	47.2	2.83	144.2	72.5
CB105	6835	64	544.8	109.0	4.14	310.7	50.8	3.13	125.0	77.4
H10/12	6570	84	663.5	112.0	4.59	313.5	51.3	3.16	138.6	78.4
H10	6935	62	654.7	117.7	4.58	215.7	41.7	2.63	136.3	64.1
H10	6954	61	651.0	117.0	4.58	215.6	41.7	2.64	136.3	64.1
H10	6707	70	671.2	119.3	4.64	220.8	42.5	2.66	137.8	64.9
CB103N	6735	69	671.0	119.3	4.64	220.8	42.5	2.66	137.8	64.9
H10	6954	61	651.0	117.0	4.58	215.6	41.7	2.64	136.3	64.1
H10a	6540	76	643.6	117.0	4.57	243.7	44.3	2.81	135.2	68.0
H10	6590	75	610.6	111.0	4.55	201.7	39.1	2.61	127.9	60.1
H10	6602	74	607.0	110.4	4.55	201.7	39.1	2.62	127.9	60.1
H10/12	5694	124	613.9	114.2	4.56	291.5	47.8	3.14	129.2	73.1
10WF	6365	86	625.0	112.4	4.61	206.6	39.9	2.65	129.2	60.9
CB103N	6392	84	624.7	112.4	4.61	206.6	39.9	2.65	129.2	60.9
CB105	6318	81	525.1	105.0	4.23	292.8	48.8	3.16	119.1	73.9
H10	6602	74	607.0	110.4	4.55	201.7	39.1	2.62	127.9	60.1
H10	6602	74	607.0	110.4	4.55	201.7	39.1	2.62	127.9	60.1
CB103N	6097	101	584.2	106.2	4.58	194.2	37.6	2.64	121.6	57.3
H10	6065	103	584.2	106.2	4.57	194.1	37.6	2.64	121.6	57.3
H10	6261	91	568.9	104.6	4.51	188.6	36.7	2.60	120.0	56.4
H10	6281	90	565.2	103.9	4.52	188.6	36.7	2.61	120.0	56.4
H10	6281	90	565.2	103.9	4.52	188.6	36.7	2.61	120.0	56.4
H10	6281	90	565.2	103.9	4.52	188.6	36.7	2.61	120.0	56.4
H10/12	5353	158	565.7	106.5	4.52	269.7	44.3	3.12	120.0	67.9
CB104	7419	58	423.2	84.6	3.96	163.1	30.6	2.46	99.3	48.5
H10	5908	114	527.2	98.1	4.49	175.2	34.2	2.59	111.9	52.6
10WF	5718	129	542.4	99.7	4.55	180.6	35.2	2.63	113.5	53.5
CB103N	5744	127	542.1	99.7	4.55	180.6	35.2	2.63	113.5	53.5
H10	5927	112	523.5	97.4	4.49	175.1	34.2	2.60	111.9	52.6
H10	5927	112	523.5	97.4	4.49	175.1	34.2	2.60	111.9	52.6
H10	5927	112	523.5	97.4	4.49	175.1	34.2	2.60	111.9	52.6

Table 2.3.1 Dimensions and Primary Properties -- Steel Sections 1887-1952

Designation	Source Reference Number	Wt. per ft lb	Area	Depth	Web Thickness	Flange Width	Average Flange Thickness	Distance	Distance	Compact Section Criteria		
			A	d	t _w	b _f	t _f	T	k	b _f /2t _f	h/t _w	F _y "
			in.2	in.	in.	in.	in.	in.	in.	in.		
H10/12	6	88.0	25.86	10.50	0.530	12.140	0.865	7.693	1.404	7.02	14.5	-
CB104	10	84.0	24.70	10.00	0.926	10.411	0.805	7.265	1.368	6.47	7.8	-
H10	5 6	83.5	24.49	10.63	0.590	10.200	0.938	7.692	1.467	5.44	13.0	-
H10	4	83.5	24.29	10.63	0.590	10.200	0.938	7.692	1.467	5.44	13.0	-
H10	7	83.0	24.42	10.75	0.575	10.235	0.933	7.759	1.496	5.48	13.5	-
CB103N	12	83.0	24.41	10.75	0.575	10.235	0.933	7.659	1.546	5.48	13.3	-
H10	1	82.6	24.29	10.63	0.590	10.200	0.938	7.692	1.467	5.44	13.0	-
H10	2	82.5	24.29	10.63	0.590	10.200	0.938	7.692	1.467	5.44	13.0	-
H10/12	6	82.0	23.98	10.38	0.490	12.100	0.805	7.688	1.344	7.52	15.7	-
H10	5 6	77.5	22.80	10.50	0.550	10.160	0.875	7.693	1.404	5.81	14.0	-
H10	4	77.5	22.59	10.50	0.550	10.160	0.875	7.693	1.404	5.81	14.0	-
10WF	7 8 9 13 14	77.0	22.67	10.62	0.535	10.195	0.868	7.759	1.431	5.87	14.5	-
CB103N	12	77.0	22.65	10.62	0.535	10.195	0.868	7.659	1.481	5.87	14.3	-
CB104	10	77.0	22.65	10.00	0.721	10.206	0.805	7.265	1.368	6.34	10.1	-
H10	2	77.0	22.59	10.50	0.550	10.160	0.875	7.693	1.404	5.81	14.0	-
H10	1	76.8	22.59	10.50	0.550	10.160	0.875	7.693	1.404	5.81	14.0	-
H10/12	6	75.0	22.00	10.25	0.450	12.060	0.740	7.693	1.279	8.15	17.1	-
10WF	7 8 9 13 14	72.0	21.18	10.50	0.510	10.170	0.808	7.759	1.371	6.29	15.2	-
CB103N	12	72.0	21.17	10.50	0.510	10.170	0.808	7.659	1.421	6.29	15.0	-
H10	5 6	72.0	21.11	10.38	0.510	10.120	0.813	7.692	1.342	6.23	15.1	-
H10	4	72.0	20.91	10.38	0.510	10.120	0.813	7.692	1.342	6.23	15.1	-
H10	1	71.1	20.91	10.38	0.510	10.120	0.813	7.692	1.342	6.23	15.1	-
H10	2	71.0	20.91	10.38	0.510	10.120	0.813	7.692	1.342	6.23	15.1	-
CB104	10	70.0	20.59	10.00	0.515	10.000	0.805	7.265	1.368	6.21	14.1	-
H10/12	6	68.0	20.13	10.13	0.420	12.030	0.675	7.698	1.214	8.91	18.3	-
H10	7	66.0	19.44	10.38	0.460	10.120	0.748	7.759	1.311	6.76	16.9	-
H10	5 6	66.0	19.44	10.25	0.470	10.080	0.750	7.693	1.279	6.72	16.4	-
CB103N	12	66.0	19.43	10.38	0.460	10.120	0.748	7.659	1.361	6.76	16.7	-
10WF	8 9 13 14	66.0	19.41	10.38	0.457	10.117	0.748	7.759	1.311	6.76	17.0	-
H10	4	66.0	19.23	10.25	0.470	10.080	0.750	7.693	1.279	6.72	16.4	-
H10	2	65.5	19.23	10.25	0.470	10.080	0.750	7.693	1.279	6.72	16.4	-
H10	1	65.4	19.23	10.25	0.470	10.080	0.750	7.693	1.279	6.72	16.4	-
CB103A	11	64.0	18.81	10.00	0.791	10.441	0.558	7.859	1.071	9.36	9.9	-
CB103	10	63.0	18.53	10.00	0.787	9.412	0.610	7.755	1.123	7.71	9.9	-
H10/12	6	62.0	18.29	10.00	0.380	11.990	0.615	7.693	1.154	9.75	20.2	-
H10	5 6	60.5	17.77	10.13	0.430	10.040	0.688	7.692	1.217	7.30	17.9	-
H10	4	60.5	17.57	10.13	0.430	10.040	0.688	7.692	1.217	7.30	17.9	-
10WF	7 8 9 13 14	60.0	17.66	10.25	0.415	10.075	0.683	7.759	1.246	7.38	18.7	-
CB103N	12	60.0	17.65	10.25	0.415	10.075	0.683	7.659	1.296	7.38	18.5	-
H10	1	59.7	17.57	10.13	0.430	10.040	0.688	7.692	1.217	7.30	17.9	-
H10	2	59.5	17.57	10.13	0.430	10.040	0.688	7.692	1.217	7.30	17.9	-
CB103A	11	59.0	17.34	10.00	0.644	10.294	0.558	7.859	1.071	9.22	12.2	-
CB103	10	56.0	16.47	10.00	0.581	9.206	0.610	7.755	1.123	7.55	13.3	-
H10	5 6	55.0	16.12	10.00	0.390	10.000	0.625	7.693	1.154	8.00	19.7	-
H10	4	55.0	15.91	10.00	0.390	10.000	0.625	7.693	1.154	8.00	19.7	-
H10	1	54.1	15.91	10.00	0.390	10.000	0.625	7.693	1.154	8.00	19.7	-
H10	2	54.0	15.91	10.00	0.390	10.000	0.625	7.693	1.154	8.00	19.7	-
H10	1	54.0	15.90	10.12	0.370	10.030	0.618	7.759	1.181	8.11	21.0	-
CB103N	12	54.0	15.89	10.12	0.370	10.030	0.618	7.659	1.231	8.11	20.7	-
10WF	8 9 13 14	54.0	15.88	10.12	0.368	10.028	0.618	7.759	1.181	8.11	21.1	-
CB103A	11	54.0	15.87	10.00	0.497	10.147	0.558	7.859	1.071	9.09	15.8	-
H10s	1	50.6	14.88	10.00	0.400	9.040	0.630	7.693	1.154	7.17	19.2	-
H10	5 6	49.5	14.57	9.88	0.360	9.970	0.563	7.692	1.092	8.86	21.4	-
H10	4	49.5	14.37	9.88	0.360	9.970	0.563	7.692	1.092	8.86	21.4	-
CB103	10	49.0	14.41	10.00	0.375	9.000	0.610	7.755	1.123	7.38	20.7	-
CB103A	11	49.0	14.40	10.00	0.350	10.000	0.558	7.859	1.071	8.96	22.5	-
10WF	7 8 9 13 14	49.0	14.40	10.00	0.340	10.000	0.558	7.759	1.121	8.96	22.8	-
CB103N	12	49.0	14.38	10.00	0.340	10.000	0.558	7.659	1.171	8.96	22.5	-
H10	2	49.0	14.37	9.88	0.360	9.970	0.563	7.692	1.092	8.86	21.4	-
H10/8	5 6	47.5	13.90	10.00	0.390	8.110	0.635	7.693	1.154	6.39	19.7	-
H10/8	3	47.5	13.70	10.00	0.390	8.110	0.635	7.693	1.154	6.39	19.7	-
H10s	1	45.4	13.36	9.88	0.360	9.000	0.568	7.692	1.092	7.93	21.4	-
10WF	8 9 13 14	45.0	13.24	10.12	0.350	8.022	0.618	7.759	1.181	6.49	22.2	-
H10a	7	45.0	13.24	10.12	0.350	8.020	0.618	7.759	1.181	6.49	22.2	-
CB102N	12	45.0	13.22	10.12	0.350	8.020	0.618	7.659	1.231	6.49	21.9	-
H10/8	5 6	42.5	12.49	9.88	0.350	8.070	0.572	7.692	1.092	7.05	22.0	-
H10/8	3	42.5	12.29	9.88	0.350	8.070	0.572	7.692	1.092	7.05	22.0	-
CB102	10	42.0	12.35	10.00	0.644	8.324	0.381	8.513	0.744	10.92	13.2	-
H10s	2	42.0	12.34	9.88	0.360	8.040	0.573	7.692	1.092	7.02	21.4	-
H10a	7	41.0	12.07	10.00	0.330	8.000	0.558	7.759	1.121	7.17	23.5	-
10WF	8 13	41.0	12.06	10.00	0.328	8.000	0.558	7.759	1.121	7.17	23.7	-
CB102N	12	41.0	12.06	10.00	0.330	8.000	0.558	7.659	1.171	7.17	23.2	-
10WF	9 14	39.0	11.48	9.94	0.318	7.990	0.528	7.759	1.091	7.57	24.4	-
H10/8	5 6	38.0	11.09	9.75	0.310	8.030	0.510	7.693	1.029	7.88	24.8	-
H10/8	3	38.0	10.89	9.75	0.310	8.030	0.510	7.693	1.029	7.88	24.8	-
H10s	1	37.2	10.95	9.75	0.320	8.000	0.510	7.693	1.029	7.85	24.0	-

Table 2.3.1 Dimensions and Primary Properties – Steel Sections 1887-1952

Designation	X ₁ ksi	X ₂ x 106 (1/ksi) ²	Elastic Properties						Plastic Modulus	
			Axis x-x			Axis y-y			Z _x in.3	Z _y in.3
			I _x	S _x	r _x	I _y	S _y	r _y		
			in.4	in.3	in.	in.4	in.3	in.		
H10/12	5034	200	522.1	99.4	4.49	249.8	41.2	3.11	111.4	63.1
CB104	6285	104	403.6	80.7	4.04	152.0	29.2	2.48	93.4	45.4
H10	5556	144	486.6	91.6	4.46	162.0	31.8	2.57	103.9	48.8
H10	5576	142	483.0	90.9	4.46	162.0	31.8	2.58	103.9	48.8
H10	5359	165	499.2	92.9	4.52	166.9	32.6	2.61	105.1	49.6
CB103N	5392	162	498.9	92.8	4.52	166.9	32.6	2.61	105.1	49.6
H10	5576	142	483.0	90.9	4.46	162.0	31.8	2.58	103.9	48.8
H10	5576	142	483.0	90.9	4.46	162.0	31.8	2.58	103.9	48.8
H10/12	4693	262	478.6	92.2	4.47	229.6	37.9	3.09	102.6	58.2
H10	5201	186	447.2	85.2	4.43	149.1	29.4	2.56	96.1	45.1
H10	5220	183	443.6	84.5	4.43	149.1	29.4	2.57	96.1	45.1
10WF	5003	216	457.2	86.1	4.49	153.4	30.1	2.60	96.9	45.7
CB103N	5029	211	456.9	86.1	4.49	153.4	30.1	2.60	96.9	45.7
CB104	5513	161	386.5	77.3	4.13	142.9	28.0	2.51	88.2	43.0
H10	5220	183	443.6	84.5	4.43	149.1	29.4	2.57	96.1	45.1
H10	5220	183	443.6	84.5	4.43	149.1	29.4	2.57	96.1	45.1
H10/12	4331	357	433.2	84.5	4.44	208.3	34.5	3.08	93.5	53.0
10WF	4696	277	420.7	80.1	4.46	141.8	27.9	2.59	89.7	42.4
CB103N	4723	270	420.4	80.1	4.46	141.8	27.9	2.59	89.7	42.4
H10	4847	244	408.9	78.8	4.40	136.5	27.0	2.54	88.4	41.4
H10	4867	239	405.2	78.1	4.40	136.5	27.0	2.56	88.4	41.4
H10	4867	239	405.2	78.1	4.40	136.5	27.0	2.56	88.4	41.4
H10	4867	239	405.2	78.1	4.40	136.5	27.0	2.56	88.4	41.4
H10	4955	223	369.3	73.9	4.24	134.3	26.9	2.55	83.1	40.8
H10/12	3982	496	390.0	77.1	4.40	187.8	31.2	3.05	84.8	47.9
H10	4337	374	382.8	73.7	4.44	129.3	25.6	2.58	82.0	38.8
H10	4490	327	371.7	72.5	4.37	124.2	24.6	2.53	80.8	37.8
CB103N	4364	364	382.5	73.7	4.44	129.3	25.6	2.58	82.0	38.8
10WF	4328	376	382.5	73.7	4.44	129.2	25.5	2.58	81.9	38.7
H10	4509	321	368.0	71.8	4.37	124.2	24.6	2.54	80.8	37.8
H10	4509	321	368.0	71.8	4.37	124.2	24.6	2.54	80.8	37.8
H10	4509	321	368.0	71.8	4.37	124.2	24.6	2.54	80.8	37.8
CB103A	4834	310	308.8	61.8	4.05	106.3	20.4	2.38	70.6	31.8
CB103	5108	252	300.4	60.1	4.03	85.2	18.1	2.14	69.1	28.4
H10/12	3644	698	350.1	70.0	4.38	168.7	28.1	3.04	76.5	43.2
H10	4129	451	335.5	66.3	4.34	112.2	22.3	2.51	73.4	34.3
H10	4149	441	331.9	65.6	4.35	112.2	22.3	2.53	73.4	34.3
10WF	3959	529	343.7	67.1	4.41	116.5	23.1	2.57	74.0	35.0
CB103N	3993	512	343.5	67.0	4.41	116.5	23.1	2.57	74.0	35.0
H10	4149	441	331.9	65.6	4.35	112.2	22.3	2.53	73.4	34.3
H10	4149	441	331.9	65.6	4.35	112.2	22.3	2.53	73.4	34.3
CB103A	4165	519	296.5	59.3	4.13	101.7	19.8	2.42	66.9	30.5
CB103	4221	482	283.2	56.6	4.15	79.5	17.3	2.20	63.9	26.6
H10	3771	640	300.4	60.1	4.32	100.4	20.1	2.50	66.1	30.8
H10	3791	625	296.8	59.4	4.32	100.4	20.1	2.51	66.1	30.8
H10	3791	625	296.8	59.4	4.32	100.4	20.1	2.51	66.1	30.8
H10	3791	625	296.8	59.4	4.32	100.4	20.1	2.51	66.1	30.8
H10	3591	770	305.9	60.4	4.39	104.0	20.7	2.56	66.2	31.4
CB103N	3620	746	305.6	60.4	4.39	104.0	20.7	2.56	66.2	31.4
10WF	3585	773	305.7	60.4	4.39	103.9	20.7	2.56	66.1	31.4
CB103A	3634	814	284.3	56.9	4.23	97.3	19.2	2.48	63.3	29.3
H10s	3884	589	272.5	54.5	4.28	75.1	16.6	2.25	61.0	25.6
H10	3434	926	267.2	54.1	4.28	89.1	17.9	2.47	59.1	27.5
H10	3455	902	263.5	53.4	4.28	89.1	17.9	2.49	59.1	27.5
CB103	3624	768	266.0	53.2	4.30	74.2	16.5	2.27	58.8	25.0
CB103A	3267	1123	272.0	54.4	4.35	93.0	18.6	2.54	59.6	28.2
10WF	3265	1117	272.9	54.6	4.35	93.0	18.6	2.54	59.4	28.2
CB103N	3300	1072	272.7	54.5	4.35	93.0	18.6	2.54	59.4	28.2
H10	3455	902	263.5	53.4	4.28	89.1	17.9	2.49	59.1	27.5
H10/8	3898	594	251.3	50.3	4.25	54.8	13.5	1.99	55.6	20.8
H10/8	3932	575	247.6	49.5	4.25	54.8	13.5	2.00	55.6	20.8
H10s	3522	861	241.4	48.9	4.25	66.4	14.8	2.23	54.4	22.7
10WF	3631	773	248.6	49.1	4.33	53.2	13.3	2.00	54.0	20.2
H10a	3631	774	248.5	49.1	4.33	53.2	13.3	2.00	54.0	20.1
CB102N	3664	744	248.3	49.1	4.33	53.2	13.3	2.01	54.0	20.1
H10/8	3533	869	223.0	45.2	4.23	48.5	12.0	1.97	49.6	18.5
H10/8	3568	838	219.4	44.4	4.23	48.5	12.0	1.99	49.6	18.5
CB102	4051	739	190.4	38.1	3.93	36.8	8.9	1.73	44.2	14.2
H10s	3595	820	219.2	44.4	4.22	48.0	11.9	1.97	49.7	18.4
H10a	3325	1099	222.5	44.5	4.29	47.7	11.9	1.99	48.7	18.1
10WF	3320	1104	222.4	44.5	4.29	47.7	11.9	1.99	48.6	18.1
CB102N	3361	1051	222.3	44.5	4.29	47.7	11.9	1.99	48.7	18.1
10WF	3169	1332	209.7	42.2	4.27	44.9	11.2	1.98	46.0	17.1
H10/8	3172	1321	195.6	40.1	4.20	42.4	10.6	1.96	43.7	16.3
H10/8	3199	1276	192.0	39.4	4.20	42.4	10.6	1.97	43.7	16.3
H10s	3225	1249	192.0	39.4	4.19	41.9	10.5	1.96	43.8	16.1

Table 2.3.1 Dimensions and Primary Properties -- Steel Sections 1887-1952

Designation	Source Reference Number	Wt. per ft lb	Area	Depth	Web Thickness	Flange Width	Average Flange Thickness	Distance	Distance	Compact Section Criteria		
			A in.2	d in.	t _w in.	b _f in.	t _f in.	T in.	k in.	b _f /2t _f	h/t _w	F _y " ksi
10WF	8 13	37.0	10.88	9.88	0.306	7.978	0.498	7.759	1.061	8.01	25.4	-
H10a	7	37.0	10.87	9.88	0.305	7.975	0.498	7.759	1.061	8.01	25.4	-
CB102N	12	37.0	10.85	9.88	0.305	7.975	0.498	7.659	1.111	8.01	25.1	-
CB102	10	36.0	10.58	10.00	0.467	8.147	0.381	8.513	0.744	10.69	18.2	-
H10/8	5 6	33.5	9.80	9.63	0.280	8.000	0.447	7.692	0.967	8.95	27.5	-
H10/8	3	33.5	9.60	9.63	0.280	8.000	0.447	7.692	0.967	8.95	27.5	-
H10a	7	33.0	9.73	9.75	0.295	7.965	0.433	7.759	0.996	9.20	26.3	-
CB102N	12	33.0	9.72	9.75	0.295	7.965	0.433	7.659	1.046	9.20	26.0	-
10WF	8 9 13 14	33.0	9.71	9.75	0.292	7.964	0.433	7.759	0.996	9.20	26.6	-
CB102	10	31.0	9.11	10.00	0.320	8.000	0.381	8.513	0.744	10.50	26.6	-
H9a	1	135.6	39.87	11.00	0.980	10.310	1.559	6.911	2.045	3.31	7.1	-
H9a	1	129.7	38.15	10.88	0.940	10.270	1.497	6.912	1.982	3.43	7.4	-
H9a	1	123.9	36.44	10.75	0.900	10.230	1.434	6.911	1.920	3.57	7.7	-
H9a	1	118.1	34.73	10.63	0.860	10.190	1.372	6.912	1.857	3.71	8.0	-
H9a	1	112.3	33.04	10.50	0.820	10.150	1.309	6.911	1.795	3.88	8.4	-
H9a	1	106.6	31.35	10.38	0.780	10.110	1.247	6.912	1.732	4.06	8.9	-
H9a	1	100.9	29.68	10.25	0.740	10.070	1.184	6.911	1.670	4.25	9.3	-
H9a	1	95.3	28.02	10.13	0.700	10.030	1.122	6.912	1.607	4.47	9.9	-
H9a	1	90.0	26.46	10.00	0.670	10.000	1.059	6.911	1.545	4.72	10.3	-
H9	1	85.3	25.08	10.00	0.670	9.320	1.063	6.911	1.545	4.39	10.3	-
H9	1	80.0	23.52	9.88	0.630	9.280	1.000	6.912	1.482	4.64	11.0	-
H9	1	74.7	21.97	9.75	0.590	9.240	0.938	6.911	1.420	4.93	11.7	-
H9	1	69.5	20.43	9.63	0.550	9.200	0.875	6.912	1.357	5.26	12.6	-
H9	1	64.3	18.90	9.50	0.510	9.160	0.813	6.911	1.295	5.64	13.6	-
H9	1	59.1	17.38	9.38	0.470	9.120	0.750	6.912	1.232	6.08	14.7	-
H9	1	54.0	15.87	9.25	0.430	9.080	0.688	6.911	1.170	6.60	16.1	-
H9	1	48.9	14.37	9.13	0.390	9.040	0.625	6.912	1.107	7.23	17.7	-
CB93	2	48.0	14.11	9.24	0.398	9.082	0.591	6.935	1.154	7.68	17.4	-
H9	1	43.8	12.88	9.00	0.350	9.000	0.563	6.911	1.045	8.00	19.7	-
CB93	2	43.0	12.65	9.12	0.357	9.041	0.531	6.935	1.094	8.51	19.4	-
H9s	1	40.6	11.95	9.00	0.360	8.040	0.568	6.911	1.045	7.08	19.2	-
CB93	2	38.0	11.17	9.00	0.316	9.000	0.470	6.935	1.033	9.57	21.9	-
H9s	1	36.0	10.59	8.88	0.320	8.000	0.505	6.912	0.982	7.93	21.6	-
CB92	2	35.0	10.29	9.19	0.335	6.556	0.566	6.935	1.129	5.79	20.7	-
H9s	1	32.9	9.69	8.88	0.320	7.040	0.510	6.912	0.982	6.91	21.6	-
CB92	2	32.0	9.40	9.10	0.307	6.528	0.518	6.935	1.081	6.30	22.6	-
CB92	2	29.0	8.53	9.00	0.279	6.500	0.470	6.935	1.033	6.91	24.9	-
H9s	1	28.8	8.46	8.75	0.280	7.000	0.448	6.911	0.920	7.82	24.7	-
H8a	1	117.1	34.45	10.00	0.940	9.310	1.497	6.130	1.935	3.11	6.5	-
H8a	1	111.8	32.89	9.88	0.900	9.270	1.434	6.129	1.873	3.23	6.8	-
H8a	1	106.6	31.35	9.75	0.860	9.230	1.372	6.130	1.810	3.36	7.1	-
H8a	1	101.3	29.81	9.63	0.820	9.190	1.309	6.129	1.748	3.51	7.5	-
H8a	1	96.1	28.28	9.50	0.780	9.150	1.247	6.130	1.685	3.67	7.9	-
H8	6	91.0	26.77	9.50	0.780	8.470	1.250	6.130	1.685	3.39	7.9	-
H8a	1	91.0	26.76	9.38	0.740	9.110	1.184	6.129	1.623	3.85	8.3	-
H8	5	91.0	26.64	9.50	0.780	8.470	1.250	6.130	1.685	3.39	7.9	-
H8	2	90.5	26.64	9.50	0.780	8.470	1.250	6.130	1.685	3.39	7.9	-
CB83	14	90.0	26.47	9.61	0.810	8.520	1.203	6.175	1.716	3.54	7.6	-
H8	6	86.0	25.33	9.38	0.740	8.430	1.188	6.129	1.623	3.55	8.3	-
H8	5	86.0	25.20	9.38	0.740	8.430	1.188	6.129	1.623	3.55	8.3	-
H8a	1	85.9	25.25	9.25	0.700	9.070	1.122	6.130	1.560	4.04	8.8	-
H8	2	85.5	25.20	9.38	0.740	8.430	1.188	6.129	1.623	3.55	8.3	-
CB83	14	84.0	24.71	9.46	0.759	8.469	1.128	6.175	1.641	3.75	8.1	-
H8	6	81.5	23.91	9.25	0.700	8.390	1.124	6.134	1.558	3.73	8.8	-
H8	5	81.5	23.78	9.25	0.700	8.390	1.125	6.130	1.560	3.73	8.8	-
H8a	1	81.1	23.84	9.13	0.670	9.040	1.059	6.129	1.498	4.27	9.1	-
H8	2	81.0	23.78	9.25	0.700	8.390	1.124	6.134	1.558	3.73	8.8	-
CB83	14	78.0	22.93	9.30	0.708	8.418	1.051	6.175	1.564	4.00	8.7	-
H8	6	77.0	22.59	9.13	0.670	8.360	1.063	6.129	1.498	3.93	9.1	-
H8	5	77.0	22.46	9.13	0.670	8.360	1.063	6.129	1.498	3.93	9.1	-
H8	2	76.5	22.46	9.13	0.670	8.360	1.063	6.129	1.498	3.93	9.1	-
H8a	1	76.0	22.35	9.00	0.630	9.000	0.997	6.130	1.435	4.52	9.7	-
H8	6	72.0	21.18	9.00	0.630	8.320	1.000	6.130	1.435	4.16	9.7	-
CB83	14	72.0	21.17	9.15	0.656	8.366	0.975	6.175	1.488	4.29	9.4	-
H8	5	72.0	21.05	9.00	0.630	8.320	1.000	6.130	1.435	4.16	9.7	-
H8	1	71.6	21.05	9.00	0.630	8.320	1.000	6.130	1.435	4.16	9.7	-
H8	2	71.5	21.05	9.00	0.630	8.320	1.000	6.130	1.435	4.16	9.7	-
H8	6	67.5	19.79	8.88	0.590	8.280	0.938	6.129	1.373	4.42	10.4	-
H8	5	67.5	19.66	8.88	0.590	8.280	0.938	6.129	1.373	4.42	10.4	-
CB83	15	67.0	19.70	9.06	0.575	8.285	0.931	6.175	1.444	4.45	10.7	-
8WF	9 10 16 17 18	67.0	19.70	9.00	0.575	8.287	0.933	6.209	1.396	4.44	10.8	-
H8	8	67.0	19.70	9.00	0.575	8.285	0.933	6.209	1.396	4.44	10.8	-
H8	2	67.0	19.66	8.88	0.590	8.280	0.938	6.129	1.373	4.42	10.4	-
H8	1	66.8	19.66	8.88	0.590	8.280	0.938	6.129	1.373	4.42	10.4	-

Table 2.3.1 Dimensions and Primary Properties -- Steel Sections 1887-1952

Designation	X ₁ ksi	X ₂ x 106 (1/ksi) ²	Elastic Properties						Plastic Modulus	
			Axis x-x			Axis y-y			Z _x in.3	Z _y in.3
			I _x in.4	S _x in.3	r _x in.	I _y in.4	S _y in.3	r _y in.		
10WF	3011	1631	196.9	39.9	4.25	42.2	10.6	1.97	43.3	16.1
H10a	3015	1628	196.8	39.8	4.26	42.1	10.6	1.97	43.3	16.0
CB102N	3051	1545	196.6	39.8	4.26	42.1	10.6	1.97	43.3	16.0
CB102	3021	2068	175.6	35.1	4.07	34.4	8.5	1.80	39.8	13.1
H10/8	2829	2075	169.9	35.3	4.16	36.6	9.1	1.93	38.2	14.1
H10/8	2865	1982	166.2	34.5	4.16	36.6	9.1	1.95	38.2	14.1
H10a	2716	2510	171.1	35.1	4.19	36.5	9.2	1.94	38.0	13.9
CB102N	2766	2343	170.8	35.0	4.19	36.5	9.2	1.94	38.0	13.9
10WF	2714	2522	170.9	35.0	4.20	36.5	9.2	1.94	37.9	13.9
CB102	2403	4410	163.4	32.7	4.23	32.5	8.1	1.89	36.1	12.4
H9a	9821	16	762.8	138.7	4.38	281.6	54.6	2.66	167.0	84.1
H9a	9460	19	720.0	132.4	4.34	266.9	52.0	2.65	158.7	80.0
H9a	9109	22	678.3	126.0	4.32	252.6	49.4	2.63	150.6	76.0
H9a	8722	25	637.8	120.1	4.29	238.6	46.8	2.62	142.7	72.0
H9a	8354	30	598.4	114.0	4.26	224.8	44.3	2.61	134.8	68.1
H9a	7978	35	560.1	108.0	4.23	211.3	41.8	2.60	127.1	64.2
H9a	7607	43	522.9	102.0	4.20	198.1	39.4	2.58	119.6	60.4
H9a	7223	52	486.8	96.2	4.17	185.2	36.9	2.57	112.1	56.7
H9a	6868	63	452.6	90.5	4.14	173.1	34.6	2.56	105.1	53.2
H9a	6934	62	424.6	84.9	4.11	140.9	30.2	2.37	98.9	46.5
H9	6548	77	392.6	79.5	4.09	130.7	28.2	2.36	92.1	43.3
H9	6156	97	361.6	74.2	4.06	120.8	26.1	2.34	85.5	40.2
H9	5767	125	331.6	68.9	4.03	111.0	24.1	2.33	79.0	37.1
H9	5372	163	302.4	63.7	4.00	101.6	22.2	2.32	72.6	34.1
H9	4980	219	274.2	58.5	3.97	92.3	20.2	2.31	66.3	31.1
H9	4582	301	246.8	53.4	3.94	83.3	18.3	2.29	60.1	28.2
H9	4188	426	220.3	48.3	3.91	74.5	16.5	2.28	54.1	25.3
CB93	3916	568	221.1	47.8	3.96	73.8	16.3	2.29	52.9	24.7
H9	3788	627	194.7	43.3	3.89	65.9	14.6	2.26	48.1	22.5
CB93	3531	846	195.5	42.9	3.93	65.4	14.5	2.28	47.0	22.0
H9s	3894	586	177.0	39.3	3.85	47.6	11.8	2.00	44.0	18.2
CB93	3145	1322	170.4	37.9	3.91	57.1	12.7	2.26	41.2	19.2
H9s	3488	897	154.6	34.8	3.82	41.5	10.4	1.98	38.7	16.0
CB92	3789	685	155.4	33.8	3.89	26.6	8.1	1.61	37.4	12.4
H9s	3572	849	138.6	31.2	3.78	28.7	8.2	1.72	34.9	12.6
CB92	3487	943	140.5	30.9	3.87	24.0	7.4	1.60	34.0	11.2
CB92	3191	1335	126.0	28.0	3.84	21.5	6.6	1.59	30.6	10.1
H9s	3162	1357	119.3	27.3	3.76	24.7	7.0	1.71	30.3	10.9
H8a	10519	12	535.9	107.2	3.94	199.3	42.8	2.41	130.0	65.9
H8a	10117	14	503.9	102.1	3.91	188.3	40.6	2.39	123.2	62.5
H8a	9718	17	472.9	97.0	3.88	177.7	38.5	2.38	116.6	59.2
H8a	9311	20	442.9	92.0	3.85	167.2	36.4	2.37	110.1	56.0
H8a	8896	23	413.8	87.1	3.83	157.0	34.3	2.36	103.7	52.8
H8	8970	23	386.8	81.4	3.80	125.1	29.6	2.16	96.9	45.5
H8a	8475	28	385.6	82.3	3.80	147.0	32.3	2.34	97.4	49.6
H8	8981	23	385.3	81.1	3.80	125.1	29.6	2.17	96.9	45.5
H8	8981	23	385.3	81.1	3.80	125.1	29.6	2.17	96.9	45.5
CB83	8569	28	391.2	81.4	3.84	124.4	29.2	2.17	96.6	44.8
H8	8548	28	360.5	76.9	3.77	117.1	27.8	2.15	91.0	42.8
H8	8559	28	359.0	76.6	3.77	117.1	27.8	2.16	91.0	42.8
H8a	8055	34	358.2	77.5	3.77	137.3	30.3	2.33	91.3	46.5
H8	8559	28	359.0	76.6	3.77	117.2	27.8	2.16	91.0	42.8
CB83	8066	36	358.6	75.8	3.81	114.5	27.0	2.15	89.4	41.5
H8	8119	34	335.0	72.4	3.74	109.2	26.0	2.14	85.2	40.1
H8	8140	33	333.5	72.1	3.75	109.2	26.0	2.14	85.3	40.1
H8a	7658	41	332.4	72.9	3.73	128.2	28.4	2.32	85.4	43.6
H8	8130	34	333.5	72.1	3.75	109.2	26.0	2.14	85.2	40.1
CB83	7545	46	326.5	70.2	3.77	104.7	24.9	2.14	82.2	38.1
H8	7723	41	311.0	68.2	3.71	102.0	24.4	2.12	79.8	37.5
H8	7746	41	309.5	67.8	3.71	101.9	24.4	2.13	79.8	37.5
H8	7746	41	309.5	67.8	3.71	101.9	24.4	2.13	79.8	37.5
H8a	7233	51	306.8	68.2	3.70	118.9	26.4	2.31	79.5	40.6
H8	7297	51	287.1	63.8	3.68	94.5	22.7	2.11	74.3	34.9
CB83	7024	60	295.9	64.7	3.74	95.3	22.8	2.12	75.2	34.9
H8	7309	50	285.6	63.5	3.68	94.4	22.7	2.12	74.3	34.9
H8	7309	50	285.6	63.5	3.68	94.4	22.7	2.12	74.3	34.9
H8	7309	50	285.6	63.5	3.68	94.4	22.7	2.12	74.3	34.9
H8	6865	64	264.0	59.5	3.65	87.2	21.1	2.10	68.8	32.4
H8	6877	64	262.5	59.2	3.65	87.1	21.0	2.11	68.8	32.4
CB83	6588	75	275.6	60.8	3.74	88.4	21.3	2.12	70.2	32.5
8WF	6611	74	271.8	60.4	3.71	88.6	21.4	2.12	69.7	32.6
H8	6610	74	271.7	60.4	3.71	88.6	21.4	2.12	69.7	32.6
H8	6877	64	262.5	59.2	3.65	87.1	21.0	2.11	68.8	32.4
H8	6877	64	262.5	59.2	3.65	87.1	21.0	2.11	68.8	32.4

Table 2.3.1 Dimensions and Primary Properties -- Steel Sections 1887-1952

Designation	Source Reference Number	Wt. per ft lb	Area	Depth	Web Thickness	Flange Width	Average Flange Thickness	Distance	Distance	Compact Section Criteria		
			A	d	t _w	b _f	t _f	T	k	b _f /2t _f	h/t _w	F _y "
			in.2	in.	in.	in.	in.	in.	in.	in.		
CB83	14	66.0	19.40	8.99	0.604	8.314	0.897	6.175	1.410	4.63	10.2	-
H8	6	62.5	18.40	8.75	0.550	8.240	0.875	6.130	1.310	4.71	11.1	-
H8	5	62.5	18.27	8.75	0.550	8.240	0.875	6.130	1.310	4.71	11.1	-
H8	1	62.1	18.27	8.75	0.550	8.240	0.875	6.130	1.310	4.71	11.1	-
H8	2	62.0	18.27	8.75	0.550	8.240	0.875	6.130	1.310	4.71	11.1	-
CB83N	15	62.0	18.22	8.94	0.520	8.230	0.871	6.175	1.384	4.72	11.9	-
H8	8	62.0	18.22	8.88	0.520	8.230	0.873	6.209	1.336	4.71	11.9	-
CB83	14	60.0	17.63	8.84	0.551	8.261	0.819	6.175	1.332	5.04	11.2	-
8WF	8 9 10 16 17 18	58.0	17.06	8.75	0.510	8.222	0.808	6.209	1.271	5.09	12.2	-
CB83N	15	58.0	17.04	8.81	0.510	8.220	0.805	6.175	1.318	5.11	12.1	-
H8	6	58.0	17.03	8.63	0.510	8.200	0.813	6.129	1.248	5.05	12.0	-
H8	5	58.0	16.90	8.63	0.510	8.200	0.813	6.129	1.248	5.05	12.0	-
H8	2	57.5	16.90	8.63	0.510	8.200	0.813	6.129	1.248	5.05	12.0	-
H8	1	57.4	16.90	8.63	0.510	8.200	0.813	6.129	1.248	5.05	12.0	-
CB83	14	54.0	15.87	8.68	0.498	8.208	0.740	6.175	1.253	5.55	12.4	-
H8	6	53.0	15.66	8.50	0.470	8.160	0.750	6.130	1.185	5.44	13.0	-
H8	8	53.0	15.60	8.62	0.465	8.175	0.743	6.209	1.206	5.50	13.4	-
CB83N	15	53.0	15.57	8.68	0.465	8.175	0.739	6.275	1.202	5.53	13.5	-
H8	3 5	53.0	15.53	8.50	0.470	8.160	0.750	6.130	1.185	5.44	13.0	-
H8	1	52.8	15.53	8.50	0.470	8.160	0.750	6.130	1.185	5.44	13.0	-
H8	6	48.5	14.31	8.38	0.430	8.120	0.688	6.129	1.123	5.91	14.3	-
H8	5	48.5	14.18	8.38	0.430	8.120	0.688	6.129	1.123	5.91	14.3	-
H8	1	48.2	14.18	8.38	0.430	8.120	0.688	6.129	1.123	5.91	14.3	-
H8	2	48.0	14.18	8.38	0.430	8.120	0.688	6.129	1.123	5.91	14.3	-
8WF	9 10 16 17 18	48.0	14.11	8.50	0.405	8.117	0.683	6.209	1.146	5.94	15.3	-
H8	8	48.0	14.11	8.50	0.405	8.115	0.683	6.209	1.146	5.94	15.3	-
CB83N	15	48.0	14.10	8.56	0.405	8.115	0.681	6.175	1.194	5.96	15.2	-
CB83	14	48.0	14.10	8.52	0.445	8.155	0.660	6.175	1.173	6.18	13.9	-
H8	6	44.0	12.96	8.25	0.390	8.080	0.625	6.130	1.060	6.46	15.7	-
H8	8	44.0	12.93	8.38	0.380	8.090	0.623	6.209	1.086	6.49	16.3	-
CB83N	15	44.0	12.92	8.44	0.380	8.090	0.621	6.175	1.134	6.51	16.3	-
H8	5	44.0	12.83	8.25	0.390	8.080	0.625	6.130	1.060	6.46	15.7	-
H8	1	43.6	12.83	8.25	0.390	8.080	0.625	6.130	1.060	6.46	15.7	-
H8	2	43.5	12.83	8.25	0.390	8.080	0.625	6.130	1.060	6.46	15.7	-
CB183	14	42.0	12.34	8.36	0.390	8.100	0.580	6.175	1.093	6.98	15.8	-
8WF	9 10 16 17 18	40.0	11.76	8.25	0.365	8.077	0.558	6.209	1.021	7.24	17.0	-
H8	8	40.0	11.75	8.25	0.365	8.075	0.558	6.209	1.021	7.24	17.0	-
CB83N	15	40.0	11.74	8.31	0.365	8.075	0.556	6.175	1.069	7.26	16.9	-
H8	6	39.5	11.63	8.13	0.350	8.040	0.563	6.129	0.998	7.15	17.5	-
H8	5	39.5	11.50	8.13	0.350	8.040	0.563	6.129	0.998	7.15	17.5	-
H8	1	39.1	11.50	8.13	0.350	8.040	0.563	6.129	0.998	7.15	17.5	-
H8	2	39.0	11.50	8.13	0.350	8.040	0.563	6.129	0.998	7.15	17.5	-
H4	13	37.7	11.00	8.00	0.500	8.125	0.459	6.232	0.884	8.85	12.5	-
CB83N	14	36.0	10.58	8.20	0.336	8.046	0.499	6.175	1.012	8.06	18.4	-
8WF	9 10 16 17 18	35.0	10.30	8.12	0.315	8.027	0.493	6.209	0.956	8.14	19.7	-
H8	8	35.0	10.30	8.12	0.315	8.025	0.493	6.209	0.956	8.14	19.7	-
H8	6	35.0	10.30	8.00	0.310	8.000	0.500	6.130	0.935	8.00	19.8	-
CB83N	15	35.0	10.28	8.18	0.315	8.025	0.491	6.175	1.004	8.17	19.6	-
H8	5	35.0	10.17	8.00	0.310	8.000	0.500	6.130	0.935	8.00	19.8	-
H8	1	34.6	10.17	8.00	0.310	8.000	0.500	6.130	0.935	8.00	19.8	-
H8	2	34.5	10.17	8.00	0.310	8.000	0.500	6.130	0.935	8.00	19.8	-
H8/6.5	6	34.5	10.10	8.13	0.350	6.600	0.570	6.129	0.998	5.79	17.5	-
H8/6.5	4	34.5	9.97	8.13	0.350	6.600	0.570	6.129	0.998	5.79	17.5	-
H	19	34.3	10.09	8.00	0.375	8.000	0.456	6.163	0.919	8.77	16.4	-
H4	18	34.3	10.07	8.00	0.375	8.000	0.459	6.331	0.835	8.71	16.9	-
H4	12 17	34.3	10.00	8.00	0.375	8.000	0.459	6.232	0.884	8.71	16.6	-
H4	11	34.0	10.00	8.00	0.375	8.000	0.459	6.232	0.884	8.71	16.6	-
8WF	9 16	33.0	9.70	8.06	0.300	8.012	0.463	6.209	0.926	8.65	20.7	-
CB83N	15	33.0	9.70	8.12	0.300	8.010	0.462	6.175	0.975	8.67	20.6	-
H8	8	33.0	9.69	8.06	0.300	8.010	0.463	6.209	0.926	8.65	20.7	-
8x8	19	32.6	9.59	8.00	0.313	7.938	0.456	6.163	0.919	8.70	19.7	-
H4	13	32.6	9.50	8.00	0.313	7.938	0.459	6.232	0.884	8.65	19.9	-
H8	6	32.0	9.30	7.88	0.310	8.000	0.438	6.129	0.873	9.14	19.8	-
H8	3 5	32.0	9.17	7.88	0.310	8.000	0.438	6.129	0.873	9.14	19.8	-
H8s	1	31.8	9.35	8.00	0.320	7.040	0.505	6.130	0.935	6.98	19.2	-
H8	2	31.5	9.17	7.88	0.310	8.000	0.438	6.129	0.873	9.14	19.8	-
H8	8	31.0	9.13	8.00	0.290	8.000	0.433	6.209	0.896	9.24	21.4	-
8WF	9 10 16 17 18	31.0	9.12	8.00	0.288	8.000	0.433	6.209	0.896	9.24	21.6	-
CB83N	14 15	31.0	9.10	8.06	0.290	8.000	0.430	6.175	0.943	9.30	21.3	-
H8/6.5	6	30.5	8.95	8.00	0.310	6.560	0.507	6.130	0.935	6.47	19.8	-
H8/6.5	4	30.5	8.82	8.00	0.310	6.560	0.507	6.130	0.935	6.47	19.8	-
H8a	8	30.0	8.83	8.12	0.310	6.570	0.493	6.209	0.956	6.66	20.0	-
CB82N	14 15	30.0	8.81	8.20	0.298	6.559	0.498	6.175	1.011	6.59	20.7	-
8WF	10 17 18	28.0	8.23	8.06	0.285	6.540	0.463	6.209	0.926	7.06	21.8	-
H8s	1	27.7	8.15	7.88	0.280	7.000	0.443	6.129	0.873	7.91	21.9	-
H8a	8	27.0	7.95	8.03	0.275	6.535	0.448	6.209	0.911	7.29	22.6	-

Table 2.3.1 Dimensions and Primary Properties -- Steel Sections 1887-1952

Designation	X ₁ ksi	X ₂ x 106 (1/ksi) ²	Elastic Properties						Plastic Modulus	
			Axis x-x			Axis y-y			Z _x in.3	Z _y in.3
			I _x in.4	S _x in.3	r _x in.	I _y in.4	S _y in.3	r _y in.		
CB83	6497	81	265.9	59.1	3.70	86.1	20.7	2.11	68.2	31.7
H8	6434	82	241.7	55.2	3.62	80.0	19.4	2.09	63.5	29.9
H8	6446	81	240.2	54.9	3.63	80.0	19.4	2.09	63.5	29.9
H8	6446	81	240.2	54.9	3.63	80.0	19.4	2.09	63.5	29.9
CB83N	6138	98	252.2	56.4	3.72	81.0	19.7	2.11	64.6	30.0
H8	6162	96	248.6	56.0	3.69	81.2	19.7	2.11	64.1	30.0
CB83	5947	113	237.1	53.7	3.67	77.1	18.7	2.09	61.4	28.5
8WF	5792	124	227.3	52.0	3.65	74.9	18.2	2.10	59.3	27.8
CB83N	5766	126	230.3	52.3	3.68	74.6	18.2	2.09	59.6	27.7
H8	5997	108	220.1	51.0	3.60	73.1	17.8	2.07	58.3	27.4
H8	6009	107	218.6	50.7	3.60	73.1	17.8	2.08	58.3	27.4
H8	6009	107	218.6	50.7	3.60	73.1	17.8	2.08	58.3	27.4
H8	6009	107	218.6	50.7	3.60	73.1	17.8	2.08	58.3	27.4
CB83	5404	164	209.2	48.2	3.63	68.3	16.6	2.07	54.7	25.4
H8	5548	145	199.3	46.9	3.57	66.4	16.3	2.06	53.2	25.0
H8	5338	169	204.7	47.5	3.62	67.7	16.6	2.08	53.8	25.2
CB83N	5277	177	207.1	47.7	3.65	67.4	16.5	2.08	54.0	25.1
H8	5573	142	197.8	46.5	3.57	66.3	16.3	2.07	53.2	25.0
H8	5573	142	197.8	46.5	3.57	66.3	16.3	2.07	53.2	25.0
H8	5106	199	179.2	42.8	3.54	59.8	14.7	2.04	48.2	22.6
H8	5131	195	177.7	42.4	3.54	59.8	14.7	2.05	48.2	22.6
H8	5131	195	177.7	42.4	3.54	59.8	14.7	2.05	48.2	22.6
H8	5131	195	177.7	42.4	3.54	59.8	14.7	2.05	48.2	22.6
8WF	4871	237	183.7	43.2	3.61	60.9	15.0	2.08	48.5	22.8
H8	4870	237	183.7	43.2	3.61	60.9	15.0	2.08	48.5	22.8
CB83N	4853	241	186.3	43.5	3.63	60.7	15.0	2.07	48.8	22.7
CB83	4842	250	182.2	42.8	3.59	59.7	14.6	2.06	48.1	22.3
H8	4665	282	159.7	38.7	3.51	53.4	13.2	2.03	43.3	20.3
H8	4484	328	165.1	39.4	3.57	55.0	13.6	2.06	43.9	20.6
CB83N	4467	333	167.5	39.7	3.60	54.8	13.6	2.06	44.2	20.6
H8	4677	278	158.3	38.4	3.51	53.4	13.2	2.04	43.3	20.3
H8	4677	278	158.3	38.4	3.51	53.4	13.2	2.04	43.3	20.3
CB183	4280	402	156.2	37.4	3.56	51.4	12.7	2.04	41.6	19.3
8WF	4092	474	146.3	35.5	3.53	49.0	12.1	2.04	39.3	18.4
H8	4089	475	146.2	35.5	3.53	49.0	12.1	2.04	39.3	18.4
CB83N	4086	478	148.3	35.7	3.55	48.8	12.1	2.04	39.6	18.4
H8	4217	416	141.0	34.7	3.48	47.2	11.7	2.01	38.5	18.0
H8	4243	406	139.5	34.3	3.48	47.2	11.7	2.03	38.5	18.0
H8	4243	406	139.5	34.3	3.48	47.2	11.7	2.03	38.5	18.0
H8	4243	406	139.5	34.3	3.48	47.2	11.7	2.03	38.5	18.0
H4	4324	442	120.8	30.2	3.31	36.9	9.1	1.83	34.4	14.6
CB83N	3715	697	131.3	32.0	3.52	43.4	10.8	2.02	35.3	16.4
8WF	3622	759	126.5	31.1	3.50	42.5	10.6	2.03	34.2	16.1
H8	3621	760	126.4	31.1	3.50	42.5	10.6	2.03	34.2	16.1
H8	3772	640	123.0	30.7	3.46	41.1	10.3	2.00	33.8	15.8
CB83N	3616	764	128.2	31.3	3.53	42.3	10.5	2.03	34.4	16.0
H8	3785	628	121.5	30.4	3.46	41.1	10.3	2.01	33.8	15.8
H8	3785	628	121.5	30.4	3.46	41.1	10.3	2.01	33.8	15.8
H8	3785	628	121.5	30.4	3.46	41.1	10.3	2.01	33.8	15.8
H8/6.5	4341	391	118.9	29.3	3.43	26.6	8.1	1.62	32.7	12.4
H8/6.5	4373	381	117.4	28.9	3.43	26.6	8.1	1.63	32.7	12.4
H	3671	783	115.5	28.9	3.40	35.1	8.8	1.87	32.2	14.8
H4	3631	813	115.5	28.9	3.40	35.1	8.8	1.87	32.4	14.9
H4	3799	670	115.5	28.9	3.40	35.1	8.8	1.87	32.4	14.0
H4	3799	670	115.4	28.9	3.40	35.0	8.8	1.87	32.4	14.0
8WF	3412	956	117.9	29.3	3.49	39.7	9.9	2.02	32.0	15.0
CB83N	3420	950	119.8	29.5	3.51	39.6	9.9	2.02	32.2	15.0
H8	3410	956	119.7	29.3	3.49	39.7	9.9	2.02	32.0	15.0
8x8	3477	923	112.8	28.2	3.45	34.2	8.6	1.90	31.2	14.5
H4	3606	782	112.8	28.2	3.45	34.2	8.6	1.90	31.4	13.7
H8	3433	953	107.2	27.2	3.40	35.8	9.0	1.96	29.8	13.8
H8	3447	932	105.7	26.9	3.40	35.8	8.9	1.98	29.8	13.8
H8s	3894	587	109.1	27.3	3.42	28.5	8.1	1.74	30.5	12.4
H8	3447	932	105.7	26.9	3.40	35.8	8.9	1.98	29.8	13.8
H8	3232	1193	109.7	27.4	3.47	37.0	9.2	2.01	29.9	14.0
8WF	3226	1200	109.7	27.4	3.47	37.0	9.2	2.01	29.9	14.0
CB83N	3230	1200	110.9	27.5	3.49	36.7	9.2	2.01	30.0	13.9
H8/6.5	3880	601	103.8	26.0	3.41	23.2	7.1	1.61	28.7	10.9
H8/6.5	3912	583	102.3	25.6	3.41	23.2	7.1	1.62	28.7	10.9
H8a	3682	748	105.4	26.0	3.46	23.3	7.1	1.63	28.6	10.8
CB82N	3694	731	107.8	26.3	3.50	23.4	7.1	1.63	29.0	10.9
8WF	3451	956	97.8	24.3	3.45	21.6	6.6	1.62	26.6	10.0
H8s	3444	943	93.6	23.8	3.39	24.4	7.0	1.73	26.4	10.7
H8a	3341	1081	94.2	23.5	3.44	20.9	6.4	1.62	25.7	9.7

Table 2.3.1 Dimensions and Primary Properties -- Steel Sections 1887-1952

Designation	Source Reference Number	Wt. per ft lb	Area	Depth	Web Thickness	Flange Width	Average Flange Thickness	Distance	Distance	Compact Section Criteria		
			A	d	t _w	b _f	t _f	T	k	b _f /2t _f	h/t _w	F _y "
			in.2	in.	in.	in.	in.	in.	in.	in.		
CB82N	14 15	27.0	7.93	8.10	0.268	6.529	0.449	6.175	0.962	7.27	23.0	-
8WF	9 16	27.0	7.93	8.03	0.273	6.528	0.448	6.209	0.911	7.29	22.7	-
H8/6.5	6	27.0	7.89	7.88	0.280	6.530	0.445	6.129	0.873	7.35	21.9	-
H8/6.5	4	27.0	7.76	7.88	0.280	6.530	0.445	6.129	0.873	7.35	21.9	-
H8a	8	24.0	7.09	7.94	0.240	6.500	0.403	6.209	0.866	8.06	25.9	-
CB82N	14 15	24.0	7.06	8.00	0.239	6.500	0.400	6.175	0.913	8.13	25.8	-
8WF	9 10 16 17 18	24.0	7.06	7.93	0.245	6.500	0.398	6.209	0.861	8.17	25.3	-
H8/6.5	6	23.5	6.85	7.75	0.250	6.500	0.382	6.130	0.810	8.51	24.5	-
H8/6.5	4	23.5	6.72	7.75	0.250	6.500	0.382	6.130	0.810	8.51	24.5	-
H8x6.5	21	27.0	7.94	8.00	0.355	6.610	0.398	6.254	0.873	8.30	17.6	-
H8x6.5	21	24.0	7.06	8.00	0.245	6.500	0.398	6.254	0.873	8.17	25.5	-
H6a	4	88.0	25.91	7.23	0.990	10.420	0.990	4.525	1.353	5.26	4.6	-
H6/10	3	88.0	25.89	7.27	0.990	10.400	0.990	4.564	1.350	5.26	4.6	-
CB61N	13	88.0	25.87	6.84	1.035	10.046	1.035	3.747	1.548	4.85	3.6	-
H6/10	3	80.0	23.53	7.10	0.905	10.315	0.905	4.565	1.265	5.70	5.0	-
H6a	4	80.0	23.53	7.06	0.905	10.335	0.905	4.525	1.268	5.71	5.0	-
CB61N	13	80.0	23.52	6.67	0.948	9.959	0.947	3.747	1.460	5.26	4.0	-
H6/10	3	73.0	21.47	6.95	0.831	10.214	0.830	4.565	1.190	6.15	5.5	-
H6a	4	73.0	21.47	6.91	0.830	10.260	0.830	4.525	1.193	6.18	5.5	-
CB61N	13	70.0	20.58	6.44	0.835	9.846	0.836	3.743	1.349	5.89	4.5	-
H6/10	3	67.0	19.70	6.82	0.765	10.175	0.766	4.565	1.126	6.64	6.0	-
H6a	4	67.0	19.69	6.78	0.765	10.195	0.765	4.525	1.128	6.66	5.9	-
H6a	4	60.0	17.67	6.63	0.690	10.120	0.690	4.525	1.053	7.33	6.6	-
H6/10	3	60.0	17.65	6.67	0.689	10.099	0.690	4.565	1.050	7.32	6.6	-
CB61N	13	60.0	17.63	6.22	0.722	9.766	0.722	3.747	1.235	6.76	5.2	-
H6/10	3	53.0	15.59	6.51	0.612	10.022	0.613	4.565	0.973	8.17	7.5	-
H6a	4	53.0	15.53	6.47	0.610	10.040	0.610	4.525	0.973	8.23	7.4	-
CB61N	13	50.0	14.70	5.99	0.606	9.617	0.607	3.747	1.120	7.92	6.2	-
H6a	4	46.0	13.55	6.32	0.535	9.965	0.535	4.525	0.898	9.31	8.5	-
H6/10	3	46.0	13.54	6.36	0.534	9.944	0.535	4.565	0.895	9.29	8.5	-
B6	5	41.0	12.04	6.75	0.495	6.245	0.750	4.525	1.113	4.16	9.1	-
H6	4	40.5	11.91	6.75	0.475	6.225	0.750	4.525	1.113	4.15	9.5	-
H6	2	40.5	11.87	6.75	0.470	6.220	0.750	4.565	1.092	4.15	9.7	-
H6	1	40.5	11.80	6.75	0.470	6.220	0.750	4.565	1.092	4.15	9.7	-
CB61N	13	40.0	11.76	5.75	0.489	9.500	0.489	3.747	1.002	9.71	7.7	-
H6a	4	40.0	11.72	6.18	0.465	9.895	0.465	4.525	0.828	10.64	9.7	-
H6/10	3	40.0	11.71	6.22	0.465	9.875	0.465	4.565	0.825	10.62	9.8	-
H6	2	37.0	10.83	6.63	0.430	6.180	0.688	4.566	1.029	4.49	10.6	-
H6	1	37.0	10.76	6.63	0.430	6.180	0.688	4.566	1.029	4.49	10.6	-
H6	2	33.5	9.80	6.50	0.390	6.140	0.625	4.565	0.967	4.91	11.7	-
H6	1	33.5	9.72	6.50	0.390	6.140	0.625	4.565	0.967	4.91	11.7	-
H6	4 5	30.0	8.81	6.38	0.350	6.100	0.565	4.525	0.928	5.40	12.9	-
H6	2	30.0	8.77	6.38	0.350	6.100	0.563	4.566	0.904	5.42	13.0	-
H6	1	30.0	8.70	6.38	0.350	6.100	0.563	4.566	0.904	5.42	13.0	-
6WF	7	27.5	8.11	6.46	0.352	6.112	0.500	4.735	0.863	6.11	13.5	-
CBS6	15	27.5	8.09	6.46	0.352	6.112	0.500	4.835	0.813	6.11	13.7	-
6WF	6	27.5	8.09	6.28	0.335	6.085	0.514	4.527	0.877	5.92	13.5	-
6H	18	27.5	8.09	6.00	0.438	6.063	0.481	4.192	0.904	6.31	9.6	-
H3a	12 17	27.5	8.08	6.00	0.438	6.063	0.481	4.192	0.904	6.31	9.6	-
H6	5	27.0	7.92	6.25	0.335	6.085	0.500	4.525	0.863	6.09	13.5	-
H3	11	26.7	7.76	6.00	0.438	6.125	0.451	4.268	0.866	6.79	9.7	-
H6	4	26.5	7.80	6.25	0.315	6.065	0.500	4.525	0.863	6.07	14.4	-
H6	2	26.5	7.76	6.25	0.310	6.060	0.500	4.565	0.842	6.06	14.7	-
H6	1	26.5	7.69	6.25	0.310	6.060	0.500	4.565	0.842	6.06	14.7	-
6WF	7 8	25.0	7.37	6.37	0.320	6.080	0.456	4.733	0.819	6.67	14.8	-
CBS6	15 16 20	25.0	7.35	6.37	0.320	6.080	0.456	4.833	0.769	6.67	15.1	-
6WF	6	25.0	7.35	6.19	0.300	6.050	0.471	4.523	0.834	6.42	15.1	-
6x6	18 20	25.0	7.35	6.00	0.313	5.938	0.481	4.287	0.857	6.17	13.7	-
H3a	12 16 17	25.0	7.33	6.00	0.313	5.938	0.481	4.192	0.904	6.18	13.4	-
H3	10 11	24.1	7.01	6.00	0.313	6.000	0.451	4.268	0.866	6.65	13.6	-
H3	9	23.8	7.00	6.00	0.313	6.000	0.451	4.268	0.866	6.65	13.6	-
H6	4 5	23.0	6.76	6.12	0.275	6.025	0.435	4.525	0.798	6.93	16.5	-
H6	2	23.0	6.76	6.13	0.270	6.020	0.438	4.566	0.779	6.88	16.9	-
H6	1	23.0	6.69	6.13	0.270	6.020	0.438	4.566	0.779	6.88	16.9	-
H3	11	22.8	6.63	6.00	0.250	5.938	0.451	4.268	0.866	6.58	17.1	-
6WF	7	22.5	6.63	6.28	0.290	6.050	0.411	4.733	0.774	7.36	16.3	-
6H	18 19	22.5	6.62	6.00	0.375	6.063	0.380	4.394	0.803	7.99	11.7	-
CBS6	15	22.5	6.61	6.28	0.290	6.050	0.411	4.833	0.724	7.36	16.7	-
H3	12 17	22.5	6.61	6.00	0.375	6.063	0.380	4.394	0.803	7.99	11.7	-
6WF	6	22.5	6.61	6.10	0.270	6.020	0.425	4.525	0.788	7.08	16.8	-
6WF	7 8	20.0	5.90	6.20	0.258	6.018	0.367	4.741	0.730	8.20	18.4	-
H6	4 5 6	20.0	5.89	6.00	0.250	6.000	0.375	4.525	0.738	8.00	18.1	-
H6	2	20.0	5.89	6.00	0.250	6.000	0.375	4.565	0.717	8.00	18.3	-
CBS6	15 16 20	20.0	5.88	6.20	0.258	6.018	0.367	4.841	0.680	8.20	18.8	-
6H	18 19 20	20.0	5.88	6.00	0.250	5.938	0.380	4.489	0.756	7.81	18.0	-

Table 2.3.1 Dimensions and Primary Properties -- Steel Sections 1887-1952

Designation	X ₁ ksi	X ₂ x 106 (1/ksi) ²	Elastic Properties						Plastic Modulus	
			Axis x-x			Axis y-y			Z _x in.3	Z _y in.3
			I _x in.4	S _x in.3	r _x in.	I _y in.4	S _y in.3	r _y in.		
CB82N	3347	1069	95.9	23.7	3.48	20.8	6.4	1.62	25.9	9.7
8WF	3345	1080	94.1	23.4	3.44	20.8	6.4	1.62	25.6	9.7
H8/6.5	3455	950	89.7	22.8	3.37	20.0	6.1	1.59	25.0	9.4
H8/6.5	3488	917	88.2	22.4	3.37	20.0	6.1	1.60	25.0	9.4
H8a	3008	1620	83.4	21.0	3.43	18.5	5.7	1.61	22.8	8.6
CB82N	3007	1620	84.2	21.1	3.46	18.3	5.6	1.61	22.9	8.6
8WF	2997	1659	82.5	20.8	3.42	18.2	5.6	1.61	22.6	8.5
H8/6.5	3040	1590	76.1	19.6	3.33	16.8	5.2	1.57	21.3	8.0
H8/6.5	3074	1525	74.6	19.2	3.33	16.8	5.2	1.58	21.3	8.0
H8x6.5	3521	992	88.5	22.1	3.34	17.4	5.3	1.48	24.6	8.4
H8x6.5	3112	1434	83.8	21.0	3.45	16.5	5.1	1.53	22.8	8.0
H6a	10234	14	215.0	59.5	2.88	187.1	35.9	2.69	71.2	55.0
H6/10	10304	13	216.9	59.7	2.89	182.0	35.0	2.65	71.5	54.1
CB61N	11807	8	187.3	54.7	2.69	175.4	34.9	2.60	66.3	53.5
H6/10	9473	19	191.7	54.0	2.85	162.0	31.4	2.62	64.1	48.5
H6a	9399	19	189.9	53.8	2.84	166.9	32.3	2.66	63.8	49.4
CB61N	10866	11	164.9	49.5	2.65	156.3	31.4	2.58	59.3	48.0
H6/10	8719	25	170.6	49.1	2.82	145.0	28.3	2.60	57.6	43.5
H6a	8653	26	168.9	48.9	2.80	149.7	29.2	2.64	57.5	44.6
CB61N	9670	17	138.7	43.0	2.60	133.3	27.1	2.54	50.9	41.4
H6/10	8067	34	153.3	45.0	2.79	130.9	25.7	2.58	52.5	39.7
H6a	8005	35	151.6	44.7	2.77	135.3	26.5	2.62	52.2	40.5
H6a	7242	51	132.6	40.0	2.74	119.3	23.6	2.60	46.2	36.0
H6/10	7295	50	133.9	40.2	2.75	114.9	22.7	2.55	46.4	35.1
CB61N	8416	28	113.9	36.7	2.54	111.1	22.8	2.51	42.8	35.1
H6/10	6512	77	115.2	35.4	2.72	99.3	19.8	2.52	40.5	30.6
H6a	6417	81	113.4	35.1	2.70	103.0	20.5	2.58	40.1	31.2
CB61N	7135	53	91.0	30.4	2.49	90.1	18.7	2.48	34.8	28.5
H6a	5657	132	96.4	30.5	2.67	88.3	17.7	2.55	34.5	26.9
H6/10	5722	127	97.4	30.6	2.68	84.1	16.9	2.49	34.7	26.1
B6	7313	51	91.2	27.0	2.75	30.5	9.8	1.59	31.5	14.9
H6	7226	53	90.7	26.9	2.76	30.2	9.7	1.59	31.3	14.8
H6	7297	51	90.5	26.8	2.76	29.6	9.5	1.58	31.2	14.6
H6	7303	51	90.1	26.7	2.76	29.6	9.5	1.58	31.2	14.6
CB61N	5814	117	69.6	24.2	2.43	69.9	14.7	2.44	27.2	22.4
H6a	4939	223	81.4	26.3	2.64	75.1	15.2	2.53	29.5	23.0
H6/10	4986	214	82.3	26.5	2.65	71.1	14.4	2.46	29.6	22.3
H6	6717	70	80.9	24.4	2.73	26.6	8.6	1.57	28.2	13.2
H6	6723	69	80.4	24.3	2.73	26.6	8.6	1.57	28.2	13.2
H6	6144	98	71.6	22.0	2.70	23.6	7.7	1.55	25.2	11.8
H6	6147	98	71.2	21.9	2.71	23.6	7.7	1.56	25.2	11.8
H6	5496	150	63.2	19.8	2.68	21.4	7.0	1.56	22.5	10.7
H6	5545	145	62.8	19.7	2.68	20.8	6.8	1.54	22.4	10.5
H6	5551	144	62.4	19.6	2.68	20.8	6.8	1.55	22.4	10.5
6WF	4865	250	59.7	18.5	2.71	19.1	6.2	1.53	20.8	9.5
CBS6	4841	256	59.6	18.4	2.71	19.0	6.2	1.53	20.8	9.5
6WF	5088	205	56.6	18.0	2.65	19.3	6.4	1.55	20.3	9.7
6H	5859	129	49.3	16.4	2.47	16.0	5.3	1.41	18.8	8.5
H3a	5856	129	49.3	16.4	2.47	16.0	5.3	1.41	18.8	8.5
H6	4974	224	55.0	17.6	2.63	18.8	6.2	1.54	19.8	9.4
H3	5584	156	47.4	15.8	2.47	15.7	5.1	1.42	18.2	8.2
H6	4895	234	54.6	17.5	2.65	18.6	6.1	1.54	19.6	9.3
H6	4955	223	54.4	17.4	2.65	18.1	6.0	1.53	19.6	9.1
H6	4961	221	53.9	17.3	2.65	18.1	6.0	1.53	19.6	9.1
6WF	4448	352	53.5	16.8	2.69	17.1	5.6	1.52	18.8	8.6
CBS6	4398	366	53.5	16.8	2.69	17.1	5.6	1.52	18.8	8.6
6WF	4650	288	50.9	16.4	2.63	17.4	5.8	1.54	18.4	8.7
6x6	4994	220	47.0	15.7	2.53	14.9	5.0	1.43	17.7	8.6
H3a	5243	180	47.0	15.7	2.53	14.9	5.0	1.43	17.7	8.1
H3	4974	225	45.1	15.0	2.54	14.7	4.9	1.45	17.0	7.8
H3	4970	225	45.1	15.0	2.54	14.7	4.9	1.45	17.0	7.8
H6	4298	389	46.3	15.1	2.62	15.9	5.3	1.53	16.8	8.0
H6	4343	368	46.4	15.2	2.62	15.4	5.1	1.51	16.8	7.9
H6	4378	359	45.9	15.0	2.62	15.4	5.1	1.52	16.8	7.9
H3	4712	260	44.0	14.7	2.58	14.2	4.8	1.46	16.5	7.5
6WF	4028	516	47.4	15.1	2.67	15.2	5.0	1.51	16.8	7.6
6H	4713	306	41.0	13.7	2.49	12.2	4.0	1.36	15.5	6.6
CBS6	4005	533	47.3	15.0	2.67	15.2	5.0	1.52	16.8	7.6
H3	4709	306	41.0	13.7	2.49	12.2	4.0	1.36	15.5	6.6
6WF	4193	425	45.0	14.8	2.61	15.5	5.1	1.53	16.4	7.8
6WF	3619	788	41.7	13.4	2.66	13.3	4.4	1.50	14.8	6.7
H6	3757	657	39.2	13.1	2.58	13.5	4.5	1.51	14.4	6.8
H6	3844	609	39.1	13.0	2.58	13.0	4.3	1.49	14.4	6.7
CBS6	3568	827	41.7	13.4	2.66	13.3	4.4	1.50	14.8	6.7
6H	3872	598	38.8	12.9	2.57	11.4	3.8	1.39	14.4	6.8

Table 2.3.1 Dimensions and Primary Properties -- Steel Sections 1887-1952

Designation	Source Reference Number	Wt. per ft	Area	Depth	Web Thickness	Flange Width	Average Flange Thickness	Distance	Distance	Compact Section Criteria		
			A	d	t _w	b _f	t _f	T	k	b/2t _f	h/t _w	F _y "
			in.2	in.	in.	in.	in.	in.	in.	in.		
H3	12 16 17	20.0	5.86	6.00	0.250	5.938	0.380	4.394	0.803	7.82	17.6	-
H6	1	20.0	5.81	6.00	0.250	6.000	0.375	4.565	0.717	8.00	18.3	-
6WF	7	18.0	5.31	6.11	0.250	6.010	0.322	4.741	0.685	9.33	19.0	-
6WF	6	18.0	5.30	5.91	0.245	5.995	0.328	4.529	0.691	9.14	18.5	-
CBS6	15	18.0	5.29	6.11	0.250	6.010	0.322	4.741	0.685	9.33	19.0	-
CBS	14	18.0	5.28	6.09	0.265	6.025	0.314	4.837	0.627	9.59	18.3	-
6WF	7 8	15.5	4.62	6.00	0.240	6.000	0.269	4.737	0.632	11.15	19.7	-
CBS6	15 16 20	15.5	4.59	6.00	0.240	6.000	0.269	4.837	0.582	11.15	20.2	-
CBS	14	15.5	4.59	6.00	0.240	6.000	0.269	4.837	0.582	11.15	20.2	-
6WF	6	15.5	4.57	5.79	0.240	5.990	0.270	4.525	0.633	11.09	18.9	-

Table 2.3.1 Dimensions and Primary Properties -- Steel Sections 1887-1952

Designation	X ₁ ksi	X ₂ x 106 (1/ksi) ²	Elastic Properties						Plastic Modulus	
			Axis x-x			Axis y-y			Z _x	Z _y
			I _x in.4	S _x in.3	r _x in.	I _y in.4	S _y in.3	r _y in.	in.3	in.3
H3	4116	465	38.8	12.9	2.57	11.4	3.8	1.39	14.4	6.2
H6	3848	600	38.7	12.9	2.58	13.0	4.3	1.50	14.4	6.7
6WF	3282	1178	36.4	11.9	2.62	11.7	3.9	1.48	13.1	5.9
6WF	3433	976	34.1	11.5	2.54	11.8	3.9	1.49	12.7	6.0
CBS6	3276	1178	36.2	11.9	2.62	11.6	3.9	1.48	13.1	5.9
CBS	3252	1244	35.5	11.7	2.59	11.0	3.6	1.44	12.9	5.8
6WF	2913	1954	30.3	10.1	2.56	9.7	3.2	1.45	11.0	4.9
CBS6	2854	2095	30.3	10.1	2.56	9.7	3.2	1.45	11.0	4.9
CBS	2882	2054	30.1	10.0	2.56	9.2	3.1	1.42	11.0	4.9
6WF	3015	1677	28.1	9.7	2.48	9.7	3.2	1.46	10.6	4.9

Table 2.3.2 Torsion Properties -- Steel Sections 1887-1952

Designation	Torsional Constant	Warping Constant	$(EC_w/GJ)1/2=$	Normalized Warping Constant	Warping Statical Moment	Statical Moment	Statical Moment
	J	Cw	a	Wno	Sw	Qf	Qw
	in.4	in.6	in.	in.2	in.4	in.3	in.3
S 24x120	13.0	11129	47.1	46.1	102	45.7	149
S 24x115	12.2	10906	48.2	45.8	101	45.7	145
S 24x115	11.9	10853	48.5	45.7	101	45.7	145
S 24x110	11.2	10617	49.5	45.4	99.4	45.7	141
S 24x110	11.0	10565	49.8	45.4	99.1	45.7	140
S 24x105.9	10.4	10342	50.8	45.1	97.8	45.7	136
S 24x105	10.4	10342	50.8	45.1	97.8	45.7	136
S 24x100	7.78	7632	50.4	44.3	82.2	39.3	123
S 24x100	7.77	7658	50.5	43.5	75.8	36.6	122
S 24x100	7.73	6494	46.6	41.9	66.3	32.7	120
S 24x100	7.73	6500	46.6	41.9	66.3	32.7	120
S 24x100	7.50	6289	46.6	41.6	64.4	32.1	118
S 24x100	7.63	6473	46.9	41.9	66.1	32.7	119
S 24x95	6.86	6299	48.7	41.6	65.1	32.7	115
S 24x95	6.88	6299	48.7	41.6	65.1	32.7	115
S 24x95	7.04	7445	52.3	43.2	74.6	36.6	118
S 24x95	7.29	7419	51.3	42.9	77.1	38.1	119
S 24x95	6.66	6103	48.7	41.3	63.4	32.1	114
S 24x95	6.79	6286	49.0	41.6	65.0	32.7	115
S 24x90	6.41	7239	54.1	42.8	73.4	36.6	114
S 24x90	6.13	6112	50.8	41.2	64.0	32.7	111
S 24x90	6.13	6112	50.8	41.2	64.0	32.7	111
S 24x90	5.92	5923	50.9	40.9	62.3	32.1	109
S 24x90	6.05	6085	51.0	41.2	63.9	32.7	110
S 24x85	5.31	5904	53.6	41.7	65.6	33.6	106
S 24x85	5.50	5931	52.9	40.9	62.9	32.7	107
S 24x85	5.50	5938	52.9	40.9	62.9	32.7	107
S 24x85	5.39	5904	53.3	40.8	62.7	32.7	106
S 24x85	5.43	5911	53.1	40.8	62.8	32.7	106
S 24x85	5.31	5747	52.9	40.6	61.2	32.1	105
S 24x80	4.88	5730	55.1	40.5	61.6	32.7	101
S 24x80	4.78	5569	54.9	40.2	60.1	32.1	100
S 24x80	4.90	5732	55.1	40.5	61.7	32.7	101
S 24x80	4.90	5737	55.1	40.5	61.7	32.7	101
S 24x79.9	4.90	5737	55.1	40.5	61.7	32.7	101
S 20x100	9.95	4819	35.4	34.8	58.1	27.9	101
S 20x100	9.59	4815	36.1	34.9	57.3	27.5	100
S 20x100	9.49	5034	37.1	34.8	61.3	29.8	100
S 20x100	9.80	4794	35.6	34.8	58.0	28.0	100
S 20x100	10.4	4439	33.3	33.5	56.1	27.8	100
S 20x100	9.69	5039	36.7	33.5	56.2	28.1	98.7
S 20x100	9.94	4417	33.9	33.4	55.7	27.8	99.1
S 20x100	9.61	4771	35.8	34.7	57.8	28.0	99.6

Table 2.3.2 Torsion Properties -- Steel Sections 1887-1952

Designation	Torsional Constant	Warping Constant	$(EC_w/GJ)^{1/2}$	Normalized Warping Constant	Warping Statical Moment	Statical Moment	Statical Moment
	J	C _w	a	W _{no}	S _w	Q _f	Q _w
	in.4	in.6	in.	in.2	in.4	in.3	in.3
S 20x98.4	9.04	4170	34.6	33.8	51.3	25.3	96.1
S 20x95	8.74	4644	37.1	34.4	56.9	27.9	96.9
S 20x95	8.37	4635	37.9	34.5	56.1	27.5	96.3
S 20x95	8.50	4858	38.5	34.5	60.2	29.8	96.7
S 20x95	8.61	4623	37.3	34.4	56.8	28.0	96.5
S 20x95	9.14	4290	34.9	33.2	55.0	27.8	96.7
S 20x95	8.83	4254	35.3	33.1	54.6	27.8	95.6
S 20x95	8.49	4863	38.5	33.1	54.9	28.1	94.7
S 20x95	8.47	4598	37.5	34.4	56.7	28.0	96.0
S 20x90	7.72	4484	38.8	34.1	55.7	27.9	93.2
S 20x90	7.33	4458	39.7	34.1	54.9	27.5	92.5
S 20x90	7.61	4459	39.0	34.0	55.7	28.0	92.8
S 20x90	7.38	3834	36.7	33.0	49.3	25.3	89.6
S 20x90	8.09	4140	36.4	32.8	53.8	27.8	93.0
S 20x90	7.87	4098	36.7	32.8	53.5	27.8	92.1
S 20x90	7.58	3798	36.0	32.8	53.8	28.1	91.2
S 20x90	7.79	3854	35.8	32.2	49.5	25.9	90.9
S 20x90	7.47	4434	39.2	34.0	55.5	28.0	92.3
S 20x85	6.83	4324	40.5	33.7	54.6	27.9	89.5
S 20x85	6.45	4323	41.6	33.8	53.8	27.5	88.8
S 20x85	6.74	4302	40.6	33.7	54.5	28.0	89.1
S 20x85	7.20	3990	37.9	32.5	52.7	27.8	89.3
S 20x85	6.37	3692	38.7	32.6	48.1	25.3	85.6
S 20x85	6.94	3947	38.4	32.4	52.3	27.8	88.1
S 20x85	6.59	3676	38.0	32.3	49.4	26.3	86.5
S 20x85	7.34	3116	33.2	30.8	45.2	24.7	87.4
S 20x85	6.64	4279	40.9	33.6	54.4	28.0	88.6
S 20x81.7	5.65	2902	36.5	31.3	38.9	21.2	79.8
S 20x81.4	6.44	3842	39.3	32.1	51.5	27.8	85.6
S 20x81.4	6.12	4170	42.0	33.4	53.6	28.0	86.0
S 20x80	5.60	2928	36.8	31.1	39.9	21.8	80.4
S 20x80	6.12	4171	42.0	33.4	53.6	28.0	86.0
S 20x80	5.63	3555	40.4	32.3	47.1	25.3	82.1
S 20x80	6.44	3840	39.3	32.1	51.5	27.8	85.6
S 20x80	5.72	4159	43.4	33.4	52.6	27.5	85.0
S 20x80	5.55	3047	37.7	30.6	40.9	22.9	80.3
S 20x78	5.22	3467	41.5	32.3	46.9	25.3	80.6
S 20x75	4.81	2812	38.9	30.8	39.0	21.8	76.7
S 20x75	4.58	2756	39.5	30.8	37.8	21.2	75.6
S 20x75	4.80	2598	37.4	29.6	36.6	21.2	75.5
S 20x75	4.68	2791	39.3	30.7	38.8	21.8	76.1
S 20x75	4.60	2772	39.5	30.7	38.7	21.8	75.6
S 20x75	4.59	2790	39.7	30.7	38.7	21.8	75.6
S 20x75	4.60	2777	39.5	30.7	38.7	21.8	75.7

Table 2.3.2 Torsion Properties -- Steel Sections 1887-1952

Designation	Torsional Constant	Warping Constant	$(EC_w/GJ)^{1/2}$	Normalized Warping Constant	Warping Statical Moment	Statical Moment	Statical Moment
	J	C _w	a	W _{no}	S _w	Q _f	Q _w
	in.4	in.6	in.	in.2	in.4	in.3	in.3
S 20x70	4.14	2699	41.1	30.4	38.1	21.8	73.0
S 20x70	3.90	2636	41.8	30.5	37.0	21.2	71.8
S 20x70	4.01	2459	39.9	29.1	35.6	21.2	71.0
S 20x70	4.03	2679	41.5	30.4	37.9	21.8	72.4
S 20x70	3.99	2679	41.7	30.4	37.9	21.8	72.1
S 20x70	3.92	2663	41.9	30.3	37.8	21.8	71.6
S 20x70	3.98	2663	41.6	30.1	37.3	21.6	71.8
S 20x70	3.97	2666	41.7	30.3	37.8	21.8	72.0
S 20x66.67	3.53	2581	43.5	30.2	36.4	21.2	69.3
S 20x65.4	3.50	2581	43.7	30.0	37.0	21.8	68.6
S 20x65.4	3.50	2574	43.6	30.0	37.0	21.8	68.6
S 20x65	3.50	2557	43.5	30.0	37.1	21.8	68.6
S 20x65	3.51	2349	41.6	28.8	34.8	21.2	67.5
S 20x65	3.50	2570	43.6	30.0	37.0	21.8	68.6
S 20x64.8	3.26	2470	44.3	30.1	35.9	21.2	67.3
S 20x64	3.26	2525	44.8	30.1	35.9	21.2	67.3
S 18x90	8.32	3789	34.3	30.9	51.9	25.5	83.6
S 18x90	7.91	3371	33.2	30.3	47.5	23.7	80.6
S 18x90	8.18	3782	34.6	30.9	51.8	25.5	83.2
S 18x85	7.31	3644	35.9	30.6	50.8	25.5	80.3
S 18x85	6.90	3235	34.8	30.0	46.4	23.7	77.4
S 18x85	7.19	3629	36.1	30.5	50.6	25.5	79.9
S 18x80	6.48	3505	37.4	30.2	49.6	25.5	77.0
S 18x80	5.97	2460	32.7	28.7	36.6	19.3	70.7
S 18x80	6.68	2882	33.4	28.3	42.9	23.2	74.7
S 18x80	6.37	3491	37.7	30.2	49.5	25.5	76.6
S 18x75.6	5.76	3374	38.9	29.9	48.5	25.5	73.6
S 18x75	5.78	3367	38.8	29.9	48.5	25.5	73.7
S 18x75	5.06	2352	34.7	28.4	35.7	19.3	67.5
S 18x75	5.89	2729	34.6	28.0	41.9	23.2	71.5
S 18x75	5.04	1917	31.4	27.4	30.0	16.6	65.2
S 18x70	4.37	2137	35.6	27.4	33.6	19.0	64.3
S 18x70	4.23	2245	37.1	28.0	34.8	19.4	63.9
S 18x70	4.23	1844	33.6	27.1	29.3	16.6	62.3
S 18x70	4.10	1844	34.1	27.0	29.2	16.6	61.7
S 18x70	4.15	1835	33.8	27.0	29.2	16.6	61.9
S 18x70	4.13	1817	33.7	27.0	29.2	16.6	61.8
S 18x67	3.82	2247	39.0	28.0	35.3	19.8	62.3
S 18x65	3.49	1758	36.1	26.7	28.5	16.6	58.9
S 18x65	3.43	1745	36.3	26.7	28.4	16.5	58.6
S 18x65	3.38	1758	36.7	26.7	28.4	16.6	58.4
S 18x65	3.61	1787	35.8	26.7	29.0	16.9	59.6
S 18x65	3.43	1753	36.4	26.7	28.4	16.6	58.6

Table 2.3.2 Torsion Properties -- Steel Sections 1887-1952

Designation	Torsional Constant	Warping Constant	(EC_w/GJ) ^{1/2} =	Normalized Warping Constant	Warping Statical Moment	Statical Moment	Statical Moment
	J	C _w	a	W _{no}	S _w	Q _f	Q _w
	in.4	in.6	in.	in.2	in.4	in.3	in.3
S 18x65	3.40	1747	36.5	26.7	28.4	16.6	58.5
S 18x60	2.86	1676	38.9	26.4	27.8	16.6	55.4
S 18x60	2.81	1676	39.3	26.3	27.7	16.6	55.1
S 18x60	2.79	1664	39.3	26.3	27.6	16.5	55.0
S 18x60	2.96	1697	38.6	26.3	28.2	16.9	56.0
S 18x60	2.84	1670	39.0	26.3	27.7	16.6	55.3
S 18x60	2.82	1662	39.1	26.3	27.7	16.6	55.1
S 18x55	2.50	1615	40.9	25.9	27.4	16.9	52.7
S 18x55	2.36	1560	41.4	26.0	26.9	16.5	51.7
S 18x55	2.36	1587	41.7	26.0	26.9	16.6	51.8
S 18x55	2.36	1586	41.8	26.0	26.9	16.5	51.7
S 18x55	2.36	1587	41.7	26.0	26.9	16.6	51.8
S 18x54.7	2.36	1604	41.9	26.0	26.9	16.6	51.8
S 18x54.7	2.36	1588	41.7	26.0	26.9	16.6	51.8
S 18x48.2	1.14	2296	72.2	32.8	30.9	15.6	46.7
S 18x48	1.14	2296	72.2	32.8	30.9	15.6	46.7
S 18x46	1.70	1495	47.8	26.0	25.9	16.3	45.7
S 18x46	1.21	1304	52.8	26.2	21.8	13.6	42.6
S 15x100	14.6	2537	21.2	23.8	41.9	20.4	73.7
S 15x100	15.8	2483	20.2	23.7	41.6	20.2	73.9
S 15x100	15.8	2486	20.2	23.7	41.6	20.2	73.9
S 15x100	15.7	2479	20.2	23.7	41.6	20.2	73.9
S 15x100	15.8	2483	20.2	23.6	41.7	20.3	74.0
S 15x100	15.3	2453	20.4	23.6	41.3	20.2	73.3
S 15x100	15.2	2448	20.4	23.6	41.3	20.2	73.2
S 15x95	12.6	2407	22.2	23.4	40.7	20.4	70.9
S 15x95	13.7	2356	21.1	23.4	40.4	20.2	71.2
S 15x95	13.7	2359	21.2	23.4	40.4	20.2	71.2
S 15x95	13.6	2352	21.2	23.4	40.4	20.2	71.1
S 15x95	13.7	2356	21.1	23.3	40.5	20.3	71.2
S 15x95	13.2	2328	21.4	23.3	40.1	20.2	70.5
S 15x95	13.1	2326	21.4	23.3	40.1	20.2	70.5
S 15x90	11.4	2233	22.5	23.0	39.3	20.3	67.9
S 15x90	10.9	2285	23.3	23.1	39.5	20.4	68.0
S 15x90	11.8	2239	22.1	23.0	39.2	20.2	68.4
S 15x90	11.8	2233	22.2	23.0	39.2	20.2	68.3
S 15x90	11.9	2236	22.1	22.9	39.4	20.3	68.4
S 15x90	11.4	2209	22.4	22.9	38.9	20.2	67.7
S 15x90	11.4	2204	22.4	22.9	38.9	20.2	67.7
S 15x85.1	9.03	2108	24.6	23.6	36.6	18.9	63.3
S 15x85	9.43	2173	24.4	22.7	38.3	20.4	65.2
S 15x85	10.3	2119	23.0	22.7	38.2	20.2	65.8
S 15x85	10.3	2125	23.1	22.7	38.1	20.2	65.7
S 15x85	10.3	2121	23.1	22.7	38.1	20.2	65.7

Table 2.3.2 Torsion Properties -- Steel Sections 1887-1952

Designation	Torsional Constant	Warping Constant	(EC_w/GJ) ^{1/2} =	Normalized Warping Constant	Warping Statical Moment	Statical Moment	Statical Moment
	J	C _w	a	W _{no}	S _w	Q _f	Q _w
	in.4	in.6	in.	in.2	in.4	in.3	in.3
S 15x85	10.3	2122	23.1	22.6	38.2	20.3	65.7
S 15x85	9.89	2095	23.4	22.6	37.8	20.2	64.9
S 15x85	9.92	2092	23.4	22.6	37.8	20.2	64.9
S 15x81.3	8.98	2036	24.2	22.3	37.0	20.2	62.9
S 15x81.3	9.00	2038	24.2	22.3	37.0	20.2	63.0
S 15x81.3	8.98	2014	24.1	22.3	37.0	20.2	62.9
S 15x80	9.26	2034	23.8	22.3	37.3	20.3	63.5
S 15x80	8.57	2063	25.0	22.6	36.6	19.7	63.0
S 15x80	9.00	2014	24.1	22.3	37.0	20.2	63.0
S 15x80	8.13	1635	22.8	22.7	29.5	15.6	58.9
S 15x80	7.72	2014	26.0	23.3	35.9	19.0	61.3
S 15x80	8.98	2036	24.2	22.3	37.0	20.2	62.9
S 15x80	8.09	1633	22.9	22.7	29.5	15.6	58.8
S 15x80	8.21	2057	25.5	22.4	37.1	20.4	62.4
S 15x80	7.89	1839	24.6	22.5	32.4	17.4	60.4
S 15x75	6.92	1781	25.8	22.3	31.9	17.4	58.5
S 15x75	7.21	1955	26.5	22.0	36.0	20.4	59.6
S 15x75	6.65	1720	25.9	22.2	31.4	17.4	57.6
S 15x75	6.75	1544	24.3	22.3	28.6	15.6	56.1
S 15x75	6.73	1543	24.4	22.3	28.6	15.6	56.1
S 15x75	6.62	1912	27.3	23.0	34.9	19.0	58.5
S 15x75	7.11	1948	26.6	22.2	37.5	21.3	60.0
S 15x75	6.55	1539	24.7	22.3	28.5	15.6	55.7
S 15x70.4	5.32	1557	27.5	22.6	28.9	16.0	53.4
S 15x70	5.61	1460	26.0	22.0	27.7	15.6	53.4
S 15x70	5.74	1818	28.6	22.6	33.8	19.0	55.7
S 15x70	6.51	1852	27.1	21.9	34.4	19.7	57.4
S 15x70	5.85	1687	27.3	22.0	30.9	17.4	55.7
S 15x70	5.74	1615	27.0	21.9	30.5	17.4	55.0
S 15x70	5.60	1459	26.0	22.0	27.7	15.6	53.3
S 15x70	5.45	1449	26.2	21.9	27.6	15.6	52.9
S 15x69.2	5.36	1794	29.4	22.5	33.3	18.9	54.6
S 15x69.2	5.90	1671	27.1	21.7	31.4	18.1	55.1
S 15x66.67	5.14	1576	28.2	21.6	29.8	17.4	53.1
S 15x66.67	5.23	1624	28.3	21.7	30.2	17.4	53.7
S 15x65	4.69	1380	27.6	21.6	26.9	15.6	50.6
S 15x65	4.68	1379	27.6	21.6	26.9	15.6	50.6
S 15x65	4.36	1467	29.5	22.3	28.1	16.1	50.4
S 15x65	4.91	1526	28.4	21.5	29.5	17.4	52.2
S 15x65	4.56	1368	27.9	21.6	26.7	15.6	50.2
S 15x60.8	3.96	1306	29.2	21.3	26.0	15.6	47.9
S 15x60.8	3.96	1308	29.3	21.3	26.0	15.6	47.9
S 15x60	3.96	1306	29.2	21.3	26.0	15.6	47.9

Table 2.3.2 Torsion Properties -- Steel Sections 1887-1952

Designation	Torsional Constant	Warping Constant		Normalized Warping Constant	Warping Statical Moment	Statical Moment	Statical Moment
	J	Cw	(ECw/GJ) ^{1/2} = a	Wno	Sw	Qf	Qw
	in.4	in.6	in.	in.2	in.4	in.3	in.3
S 15x60	3.50	939	26.4	21.0	19.0	11.3	43.8
S 15x60	3.68	1390	31.3	21.9	27.2	16.1	47.6
S 15x60	3.82	1520	32.1	21.7	28.5	17.1	48.3
S 15x60	4.32	1511	30.1	21.3	28.9	17.4	50.1
S 15x60	4.26	1451	29.7	21.2	28.6	17.4	49.4
S 15x59	4.50	1498	29.4	21.0	29.3	18.1	49.4
S 15x57.6	3.41	1358	32.1	21.6	26.6	16.0	46.1
S 15x56.9	3.04	1100	30.6	21.3	22.0	13.3	43.5
S 15x56.5	2.79	1078	31.7	21.1	21.8	13.4	42.8
S 15x55	2.97	1129	31.4	20.8	22.9	14.2	43.8
S 15x55	2.98	1127	31.3	20.8	22.9	14.2	43.8
S 15x55	2.83	882	28.4	20.7	18.5	11.4	41.5
S 15x55	2.82	882	28.4	20.7	18.5	11.4	41.4
S 15x55	2.76	882	28.7	20.7	18.5	11.4	41.2
S 15x55	2.74	1043	31.4	21.2	21.3	13.0	42.3
S 15x55	2.71	879	29.0	20.6	18.4	11.4	41.0
S 15x52.9	2.35	885	31.2	20.8	18.1	11.2	39.3
S 15x50	2.21	834	31.3	20.3	17.9	11.4	38.7
S 15x50	2.21	829	31.2	20.3	17.9	11.4	38.7
S 15x50	2.16	829	31.5	20.3	17.8	11.4	38.5
S 15x50	2.23	984	33.8	20.8	20.6	13.0	39.5
S 15x50	2.49	1066	33.3	20.5	22.1	14.2	41.0
S 15x50	2.12	827	31.8	20.3	17.8	11.4	38.2
S 15x49.3	2.18	1008	34.6	20.7	20.9	13.3	39.3
S 15x48	2.03	981	35.4	20.5	20.6	13.4	38.2
S 15x47.5	1.81	756	32.9	20.4	16.2	10.4	36.0
S 15x45	1.75	784	34.1	20.0	17.3	11.4	35.9
S 15x45	1.75	775	33.9	20.0	17.3	11.4	36.0
S 15x45	1.72	780	34.3	19.9	17.2	11.4	35.7
S 15x45	1.67	774	34.7	19.9	17.1	11.3	35.3
S 15x45	1.65	764	34.6	20.1	16.5	10.8	35.2
S 15x45	1.54	753	35.5	20.0	16.4	10.8	34.6
S 15x45	1.68	775	34.5	19.9	17.2	11.4	35.5
S 15x42.9	1.54	756	35.7	19.8	16.9	11.4	34.3
S 15x42.9	1.54	755	35.6	19.8	16.9	11.4	34.3
S 15x42.4	1.53	756	35.8	19.8	16.9	11.3	34.2
S 15x42	1.54	756	35.7	19.8	16.9	11.4	34.3
S 15x42	1.34	727	37.5	19.8	16.1	10.8	32.9
S 15x42	1.53	746	35.6	19.8	16.9	11.3	34.2
S 15x41.2	1.37	770	38.2	20.0	16.7	11.2	32.8
S 15x41	1.37	727	37.1	19.8	16.1	10.8	32.9
S 15x41	1.37	727	37.1	19.8	16.1	10.8	32.9
S 15x39	1.18	683	38.7	19.8	15.2	10.4	31.3
S 15x37.5	0.72	1052	61.3	24.5	18.9	10.6	30.6

Table 2.3.2 Torsion Properties -- Steel Sections 1887-1952

Designation	Torsional Constant	Warping Constant	$(EC_w/GJ)^{1/2}$	Normalized Warping Constant	Warping Statical Moment	Statical Moment	Statical Moment
	J	C _w	a	W _{no}	S _w	Q _f	Q _w
	in.4	in.6	in.	in.2	in.4	in.3	in.3
S 15x37.3	0.72	1052	61.3	24.5	18.9	10.6	30.6
S 15x36	1.09	701	40.9	19.8	16.0	11.0	30.2
S 15x36	0.90	630	42.5	20.1	14.3	9.69	28.9
S 15x36	1.09	701	40.9	19.8	16.0	11.0	30.2
S 15x36	1.09	701	40.9	19.8	16.0	11.0	30.2
S 15x35	0.74	608	46.3	20.0	13.4	9.19	27.7
S 15x33	0.79	609	44.7	19.9	14.0	9.69	27.3
S 12x66.9	6.38	917	19.3	16.8	22.7	12.9	41.1
S 12x65	5.76	894	20.0	16.6	22.1	12.8	39.9
S 12x65	5.56	904	20.5	17.5	21.7	12.0	39.8
S 12x60	4.03	677	20.8	16.9	16.6	9.54	34.3
S 12x60	4.80	833	21.2	16.3	21.2	12.8	37.8
S 12x60	5.05	606	17.6	16.3	15.4	8.96	35.0
S 12x60	4.41	844	22.3	17.1	20.9	12.0	37.4
S 12x56.7	3.92	688	21.3	16.7	17.1	10.0	34.5
S 12x56.67	3.90	684	21.3	16.7	17.1	10.0	34.5
S 12x55.5	4.06	780	22.3	16.0	20.5	12.9	35.9
S 12x55	3.88	564	19.4	15.9	14.8	8.96	32.8
S 12x55	3.87	561	19.4	15.9	14.8	8.96	32.8
S 12x55	3.82	561	19.5	15.9	14.7	8.96	32.7
S 12x55	4.06	776	22.2	16.0	20.3	12.8	35.6
S 12x55	3.61	791	23.8	16.8	20.0	12.0	35.3
S 12x55	3.72	556	19.7	15.9	14.7	8.96	32.5
S 12x50	2.95	521	21.4	15.6	14.1	8.96	30.6
S 12x50	2.94	518	21.4	15.6	14.1	8.96	30.6
S 12x50	2.90	518	21.5	15.6	14.1	8.96	30.5
S 12x50	2.75	620	24.2	16.3	16.1	10.0	31.5
S 12x50	2.75	620	24.2	16.3	16.1	10.0	31.5
S 12x50	2.33	582	25.4	16.2	15.2	9.54	29.8
S 12x50	2.94	655	24.0	15.9	17.4	11.1	32.1
S 12x50	2.82	514	21.7	15.5	14.0	8.96	30.3
S 12x48	2.31	579	25.5	16.2	15.2	9.54	29.8
S 12x47.6	2.47	529	23.5	15.4	14.3	9.33	29.5
S 12x45	2.25	481	23.5	15.2	13.5	8.96	28.4
S 12x45	2.25	479	23.5	15.2	13.5	8.96	28.4
S 12x45	2.21	479	23.7	15.2	13.5	8.96	28.3
S 12x45	2.15	494	24.4	15.2	13.9	9.29	28.3
S 12x45	2.15	579	26.4	15.9	15.4	10.0	29.2
S 12x45	2.13	576	26.4	15.9	15.4	10.0	29.1
S 12x45	2.16	476	23.9	15.2	13.4	8.96	28.1
S12x44.1	1.99	376	22.1	15.3	10.4	6.80	25.8
S 12x40.8	1.75	443	25.6	14.9	12.9	8.96	26.2
S 12x40.8	1.75	444	25.6	14.9	12.9	8.96	26.2

Table 2.3.2 Torsion Properties -- Steel Sections 1887-1952

Designation	Torsional Constant	Warping Constant		Normalized Warping Constant	Warping Statical Moment	Statical Moment	Statical Moment
	J	Cw	(ECw/GJ) ^{1/2} = a	Wno	Sw	Qf	Qw
	in.4	in.6	in.	in.2	in.4	in.3	in.3
S 12x40	1.75	444	25.6	14.9	12.9	8.96	26.2
S 12x40	1.74	537	28.3	15.6	14.8	10.0	27.0
S 12x40	1.72	457	26.2	14.9	13.3	9.29	26.1
S 12x40	1.75	444	25.6	14.9	12.9	8.96	26.2
S 12x40	1.52	359	24.7	14.9	10.6	7.26	24.6
S 12x40	1.84	535	27.4	15.5	15.1	10.2	27.4
S 12x40	1.74	537	28.3	15.6	14.8	10.0	27.0
S 12x39.4	1.64	467	27.2	14.9	13.3	9.33	25.9
S 12x39	1.41	398	27.0	15.5	11.3	7.51	24.5
S 12x39	1.38	342	25.4	15.0	9.92	6.80	23.6
S 12x38.4	1.29	337	26.0	14.9	9.77	6.76	23.1
S 12x38	1.45	502	29.9	15.5	13.9	9.54	25.3
S 12x37.5	1.28	379	27.7	15.5	10.8	7.26	23.7
S 12x36.6	1.16	332	27.3	14.8	9.69	6.80	22.5
S 12x36	1.16	379	29.1	15.3	11.0	7.51	23.1
S 12x35	1.08	346	28.8	15.0	10.3	7.20	22.3
S 12x35	1.10	330	27.9	14.6	10.1	7.24	22.3
S 12x35	1.10	330	27.8	14.6	10.1	7.25	22.3
S 12x35	1.06	328	28.3	14.5	10.0	7.26	22.1
S 12x35	1.08	328	28.0	14.5	10.0	7.24	22.2
S 12x34.1	0.97	319	29.2	14.6	9.45	6.80	21.3
S 12x32	1.04	380	30.8	15.0	11.4	8.16	22.1
S 12x32	0.92	338	30.9	15.0	10.6	7.51	21.3
S 12x31.8	0.90	312	29.9	14.3	9.74	7.24	20.8
S 12x31.8	0.90	312	29.9	14.3	9.74	7.24	20.8
S 12x31.67	0.83	303	30.8	14.4	9.23	6.80	20.2
S 12x31.5	0.90	310	29.8	14.3	9.75	7.26	20.8
S 12x31.5	0.87	339	31.8	14.7	9.91	7.20	20.7
S 12x31.5	0.90	312	29.9	14.3	9.75	7.25	20.8
S 12x31.5	0.90	312	29.9	14.3	9.74	7.24	20.8
S 12x30.6	0.77	297	31.7	14.4	9.07	6.76	19.6
S 12x30.5	0.77	298	31.7	14.4	9.12	6.80	19.7
S 12x30	0.79	336	33.2	15.0	10.1	7.26	20.1
S 12x28	0.43	460	52.8	18.9	11.5	6.66	18.9
S 12x28	0.44	423	50.0	17.4	10.7	6.79	18.7
S 12x27.9	0.44	423	50.0	17.4	10.7	6.79	18.7
S 12x27.5	0.59	267	34.3	14.6	8.56	6.36	18.1
S 12x27.5	0.66	287	33.7	14.4	9.20	6.98	18.6
S 12x27.5	0.66	287	33.7	14.4	9.20	6.98	18.6
S 12x25	0.32	445	60.0	18.7	10.8	6.40	17.0
S 12x25	0.40	245	39.8	14.5	7.60	5.75	16.4
S 12x25	0.51	253	35.8	14.4	8.35	6.36	17.0
S 10x45	3.26	371	17.2	11.9	14.1	9.83	25.3
S 10x40	1.89	295	20.1	12.2	10.2	6.98	21.2

Table 2.3.2 Torsion Properties -- Steel Sections 1887-1952

Designation	Torsional Constant	Warping Constant	(ECw/GJ) ^{1/2} =	Normalized Warping Constant	Warping Statical Moment	Statical Moment	Statical Moment
	J	Cw	a	Wno	Sw	Qf	Qw
	in.4	in.6	in.	in.2	in.4	in.3	in.3
S 10x40	2.02	215	16.6	12.1	7.59	5.08	19.5
S 10x40	1.87	272	19.4	12.1	9.64	6.63	20.6
S 10x40	1.85	294	20.3	12.2	10.2	6.98	21.1
S 10x40	2.03	215	16.5	12.1	7.60	5.08	19.6
S 10x40	1.98	212	16.7	12.1	7.57	5.08	19.4
S 10x40	1.70	279	20.6	12.1	9.83	6.78	20.5
S 10x35	1.33	193	19.4	11.8	7.17	5.08	17.7
S 10x35	1.42	268	22.2	11.8	9.66	6.98	19.3
S 10x35	1.33	193	19.4	11.8	7.16	5.08	17.7
S 10x35	1.37	246	21.5	11.7	9.09	6.63	18.8
S 10x35	1.29	192	19.6	11.8	7.14	5.08	17.6
S 10x34.9	1.29	223	21.1	11.5	8.13	5.96	18.2
S 10x33	1.28	258	22.9	11.7	9.43	6.98	18.6
S 10x33	1.24	258	23.2	11.7	9.43	7.01	18.4
S 10x33	1.28	258	22.9	11.7	9.43	6.98	18.6
S 10x32	1.01	189	22.0	11.8	7.04	5.11	16.6
S 10x32	1.10	237	23.7	11.6	8.93	6.78	17.5
S 10x31.5	0.95	185	22.4	11.8	6.83	4.96	16.3
S 10x30.3	0.87	153	21.3	11.2	5.87	4.46	15.2
S 10x30.13	0.85	152	21.5	11.2	5.87	4.46	15.2
S 10x30.0	0.86	182	23.4	11.6	6.88	5.11	15.9
S 10x30.0	0.87	173	22.7	11.4	6.75	5.08	15.9
S 10x30.0	0.87	173	22.7	11.4	6.74	5.08	15.9
S 10x30.0	0.83	171	23.1	11.4	6.68	5.07	15.6
S 10x30.0	0.85	183	23.6	11.6	6.90	5.12	15.9
S 10x30.0	0.85	172	22.9	11.4	6.72	5.08	15.8
S 10x29.8	0.94	201	23.5	11.2	7.64	5.96	16.3
S 10x28	0.70	145	23.2	11.1	5.72	4.46	14.4
S 10x27	0.69	172	25.4	11.4	6.67	5.12	14.9
S 10x25.9	0.57	138	25.0	10.9	5.56	4.46	13.6
S 10x25.5	0.61	166	26.5	11.3	6.51	5.11	14.2
S 10x25.5	0.59	184	28.4	11.9	6.85	5.40	14.9
S 10x25.4	0.60	156	25.9	11.1	6.34	5.08	14.0
S 10x25.4	0.60	156	25.9	11.1	6.34	5.08	14.0
S 10x25.33	0.61	166	26.5	11.3	6.51	5.11	14.2
S 10x25	0.60	165	26.7	11.3	6.48	5.11	14.1
S 10x25	0.60	156	25.9	11.1	6.34	5.08	14.0
S 10x25	0.60	154	25.8	11.1	6.32	5.07	14.0
S 10x25	0.60	165	26.7	11.3	6.51	5.12	14.1
S 10x23.8	0.52	161	28.4	11.2	6.22	4.96	13.4
S 10x23.5	0.48	131	26.6	10.7	5.38	4.46	12.7
S 10x23.33	0.46	131	27.0	10.7	5.38	4.46	12.7
S 10x23	0.30	218	43.3	13.8	6.99	4.59	12.7
S 10x22.4	0.30	208	42.4	13.2	6.89	4.78	12.7

Table 2.3.2 Torsion Properties -- Steel Sections 1887-1952

Designation	Torsional Constant	Warping Constant	$(EC_w/GJ)^{1/2}$	Normalized Warping Constant	Warping Statical Moment	Statical Moment	Statical Moment
	J	C _w	a	W _{no}	S _w	Q _f	Q _w
	in.4	in.6	in.	in.2	in.4	in.3	in.3
S 10x22.25	0.30	208	42.4	13.2	6.89	4.78	12.7
S 10x22	0.45	146	28.9	11.1	6.01	4.89	12.7
S 10x22	0.33	158	35.3	12.0	6.00	4.56	12.2
S 10x21	0.26	212	46.0	13.7	6.87	4.59	12.1
S 9x35	1.47	193	18.4	10.5	7.73	5.46	16.7
S 9x35	1.60	132	14.6	10.2	5.56	3.97	15.2
S 9x35	1.72	135	14.2	10.2	5.61	3.96	15.5
S 9x35	1.72	133	14.2	10.2	5.61	3.96	15.5
S 9x35	1.65	133	14.5	10.2	5.57	3.96	15.3
S 9x35	1.59	132	14.6	10.2	5.55	3.96	15.2
S 9x35	1.61	133	14.6	10.2	5.56	3.96	15.2
S 9x33	1.28	185	19.3	10.4	7.54	5.46	16.1
S 9x30	1.05	118	17.0	9.87	5.23	3.96	13.8
S 9x30	0.99	159	20.4	10.3	6.62	4.92	14.7
S 9x30	0.98	127	18.3	10.3	5.42	3.98	13.7
S 9x30	1.05	117	17.0	9.87	5.23	3.96	13.8
S 9x30	1.01	117	17.3	9.84	5.20	3.96	13.7
S 9x30	0.98	117	17.5	9.82	5.18	3.96	13.6
S 9x30	0.98	116	17.5	9.82	5.20	3.97	13.6
S 9x30	0.98	116	17.5	9.82	5.18	3.96	13.6
S 9x30	1.04	172	20.7	10.2	7.24	5.46	15.1
S 9x28.6	0.89	94	16.6	9.82	4.72	3.62	12.9
S 9x28.33	0.82	122	19.6	10.1	5.29	3.98	13.1
S 9x27	0.87	161	21.9	10.0	6.94	5.46	14.1
S 9x26	0.66	115	21.3	10.0	5.13	3.98	12.4
S 9x25.4	0.60	98	20.6	9.57	4.48	3.62	11.7
S 9x25	0.64	104	20.5	9.53	4.87	3.96	12.2
S 9x25	0.62	103	20.8	9.49	4.84	3.96	12.0
S 9x25	0.64	103	20.4	9.53	4.87	3.96	12.2
S 9x25	0.60	102	21.0	9.47	4.82	3.96	11.9
S 9x25	0.59	102	21.2	9.46	4.80	3.96	11.9
S 9x25	0.59	102	21.1	9.46	4.82	3.97	11.9
S 9x25	0.58	112	22.3	9.91	5.05	3.98	12.0
S 9x24.5	0.67	140	23.2	9.89	6.14	4.92	12.8
S 9x24.5	0.42	91	23.8	9.53	4.47	3.73	10.7
S 9x23.33	0.51	108	23.5	9.80	4.94	3.98	11.5
S 9x21.8	0.45	94.1	23.2	9.25	4.59	3.96	10.8
S 9x21.8	0.45	94.8	23.2	9.25	4.59	3.96	10.8
S 9x21.45	0.46	94.1	23.1	9.24	4.60	3.97	10.9
S 9x21	0.45	94.1	23.2	9.25	4.59	3.96	10.8
S 9x21	0.41	102	25.3	9.63	4.77	3.98	10.7
S 9x21	0.45	94.1	23.2	9.25	4.59	3.96	10.8
S 9x21	0.44	94.8	23.7	9.21	4.56	3.96	10.7
S 9x21	0.46	92.3	22.8	9.24	4.60	3.97	10.9

Table 2.3.2 Torsion Properties -- Steel Sections 1887-1952

Designation	Torsional Constant	Warping Constant	$(EC_w/GJ)^{1/2}$	Normalized Warping Constant	Warping Statical Moment	Statical Moment	Statical Moment
	J	C _w	a	W _{no}	S _w	Q _f	Q _w
	in.4	in.6	in.	in.2	in.4	in.3	in.3
S 9x20.5	0.36	86.9	24.9	9.22	4.16	3.62	10.1
S 9x20.03	0.37	86.9	24.8	9.22	4.16	3.62	10.1
S 9x19.75	0.36	92.5	25.8	9.41	4.36	3.73	10.2
S 8x32	0.98	109	17.0	8.98	5.38	3.98	12.3
S 8x28.33	0.92	110	17.6	8.86	5.35	4.04	12.1
S 8x27	0.82	106	18.3	8.77	5.24	4.04	11.7
S 8x27	0.82	97.2	17.5	8.55	4.87	3.83	11.5
S 8x25.5	0.77	68.6	15.1	8.10	3.68	3.01	10.4
S 8x25.5	0.76	68.3	15.2	8.09	3.68	3.01	10.3
S 8x25.5	0.77	68.1	15.1	8.10	3.68	3.01	10.4
S 8x25.5	0.76	68.1	15.2	8.09	3.67	3.01	10.3
S 8x25.5	0.74	67.4	15.3	8.07	3.65	3.00	10.2
S 8x25.5	0.74	67.6	15.4	8.07	3.66	3.01	10.3
S 8x25.5	0.74	67.4	15.4	8.07	3.66	3.01	10.3
S 8x25.25	0.76	68.3	15.2	8.09	3.68	3.01	10.3
S 8x25.25	0.74	67.6	15.4	8.07	3.66	3.01	10.3
S 8x25	0.68	76.9	17.2	8.56	3.96	3.11	10.3
S 8x25	0.68	76.9	17.2	8.56	3.96	3.11	10.3
S 8x25	0.55	93.7	21.0	8.51	4.82	3.98	10.3
S 8x25	0.67	75.5	17.1	8.56	3.92	3.09	10.2
S 8x25	0.67	92.3	18.9	8.42	4.73	3.83	10.9
S 8x24.3	0.64	55.0	14.9	8.10	3.37	2.77	9.71
S 8x23	0.57	63.3	16.9	7.92	3.53	3.01	9.64
S 8x23	0.57	63.3	17.0	7.92	3.52	3.01	9.62
S 8x23	0.57	63.0	16.8	7.92	3.53	3.01	9.64
S 8x23	0.57	63.0	17.0	7.91	3.52	3.01	9.60
S 8x23	0.56	62.4	17.0	7.90	3.50	3.00	9.52
S 8x23	0.55	62.7	17.2	7.90	3.50	3.01	9.53
S 8x23	0.55	63.1	17.2	7.90	3.50	3.01	9.54
S 8x22.75	0.57	63.3	17.0	7.92	3.52	3.01	9.62
S 8x22.75	0.55	62.5	17.2	7.90	3.50	3.01	9.53
S 8x22	0.55	92.8	20.8	8.43	4.83	4.04	10.2
S 8x22	0.53	84.7	20.3	8.21	4.50	3.83	10.0
S 8x23	0.41	105	25.7	10.52	4.38	2.93	9.55
S 8x21.7	0.45	70.3	20.0	8.32	3.74	3.11	9.32
S 8x21.2	0.43	57.3	18.6	7.88	3.18	2.77	8.75
S 8x21	0.29	101	29.7	10.39	4.27	2.94	8.92
S 8x20.5	0.43	58.7	18.8	7.75	3.37	3.01	8.91
S 8x20.5	0.43	58.5	18.8	7.74	3.37	3.01	8.89
S 8x20.5	0.43	58.4	18.7	7.75	3.37	3.01	8.91
S 8x20.5	0.43	58.4	18.9	7.74	3.36	3.01	8.87
S 8x20.5	0.42	57.9	19.0	7.73	3.35	3.01	8.81
S 8x20.5	0.41	57.7	19.1	7.71	3.33	3.00	8.72

Table 2.3.2 Torsion Properties -- Steel Sections 1887-1952

Designation	Torsional Constant	Warping Constant	(ECw/GJ) ^{1/2} =	Normalized Warping Constant	Warping Statical Moment	Statical Moment	Statical Moment
	J	Cw	a	Wno	Sw	Qf	Qw
	in.4	in.6	in.	in.2	in.4	in.3	in.3
S 8x20.5	0.42	57.4	18.9	7.72	3.35	3.01	8.80
S 8x20.25	0.43	58.5	18.8	7.74	3.37	3.01	8.89
S 8x20.25	0.42	57.9	19.0	7.73	3.35	3.01	8.81
S 8x20	0.37	62.3	20.8	7.96	3.47	3.05	8.67
S 8x19	0.22	95.5	33.3	10.2	4.15	2.93	8.35
S 8x18.4	0.34	54.2	20.5	7.57	3.22	3.01	8.17
S 8x18.4	0.34	54.5	20.5	7.57	3.22	3.01	8.17
S 8x18	0.34	54.4	20.5	7.57	3.22	3.01	8.17
S 8x18	0.34	54.2	20.5	7.57	3.22	3.01	8.17
S 8x18	0.31	62.6	22.9	8.06	3.51	3.11	8.22
S 8x18	0.31	61.6	22.7	8.07	3.48	3.09	8.17
S 8x18	0.34	53.4	20.2	7.58	3.22	3.00	8.16
S 8x18	0.34	54.2	20.5	7.57	3.22	3.01	8.17
S 8x18	0.31	56.8	21.8	7.83	3.36	3.05	8.11
S 8x17.75	0.34	54.2	20.5	7.57	3.22	3.01	8.17
S 8x17.75	0.34	54.2	20.5	7.57	3.22	3.01	8.17
S 8x17.5	0.30	64.8	23.8	8.21	3.66	3.22	8.11
S 8x17.5	0.20	90.7	34.3	9.56	4.17	3.19	8.13
S 8x17.4	0.27	51.0	21.9	7.61	2.97	2.77	7.63
S 8x17.23	0.27	51.0	22.0	7.61	2.97	2.77	7.63
S 8x17	0.17	91.2	36.9	10.10	4.04	2.93	7.79
S 7x26.67	0.92	72.9	14.3	7.37	4.18	3.23	9.88
S 7x25.2	0.80	65.1	14.5	7.46	3.85	2.97	9.35
S 7x22	0.57	62.4	16.9	7.04	3.82	3.23	8.64
S 7x22	0.53	55.0	16.5	6.79	3.47	3.04	8.28
S 7x21.33	0.54	47.1	15.0	7.05	2.93	2.43	7.89
S 7x20.2	0.45	31.9	13.5	6.62	2.38	2.10	7.14
S 7x20	0.47	35.7	14.0	6.40	2.43	2.21	7.25
S 7x20	0.48	58.3	17.7	6.91	3.67	3.23	8.12
S 7x20	0.46	35.4	14.0	6.39	2.42	2.21	7.22
S 7x20	0.45	35.0	14.2	6.38	2.40	2.20	7.15
S 7x20	0.42	44.2	16.5	6.92	2.83	2.43	7.43
S 7x20	0.45	33.8	13.9	6.38	2.41	2.21	7.17
S 7x20	0.45	51.5	17.3	6.66	3.34	3.04	7.79
S 7x19	0.36	42.7	17.4	6.85	2.77	2.43	7.17
S 7x18.3	0.38	53.8	19.1	6.98	3.38	2.97	7.58
S 7x18	0.32	47.0	19.5	6.82	2.63	2.33	6.89
S 7x17.9	0.33	33.4	16.3	6.46	2.26	2.10	6.52
S 7x17.5	0.33	32.2	15.9	6.22	2.30	2.21	6.60
S 7x17.5	0.33	32.1	16.0	6.22	2.29	2.21	6.58
S 7x17.5	0.31	31.7	16.3	6.20	2.27	2.20	6.48
S 7x17.5	0.31	37.6	17.8	6.58	2.52	2.32	6.72
S 7x17.5	0.32	31.7	16.1	6.20	2.28	2.21	6.53
S 7x15.5	0.24	37.9	20.2	6.61	2.58	2.43	6.27

Table 2.3.2 Torsion Properties -- Steel Sections 1887-1952

Designation	Torsional Constant	Warping Constant	$(EC_w/GJ)^{1/2}$	Normalized Warping Constant	Warping Statical Moment	Statical Moment	Statical Moment
	J	C _w	a	W _{no}	S _w	Q _f	Q _w
	in.4	in.6	in.	in.2	in.4	in.3	in.3
S 7x15.3	0.24	29.1	17.7	6.05	2.17	2.21	5.95
S 7x15.3	0.24	29.5	17.8	6.05	2.17	2.21	5.95
S 7x15.25	0.23	37.1	20.6	6.63	2.48	2.33	6.19
S 7x15	0.24	28.8	17.8	6.05	2.16	2.20	5.93
S 7x15	0.24	29.1	17.7	6.05	2.17	2.21	5.95
S 7x15	0.23	37.4	20.5	6.58	2.55	2.43	6.15
S 7x15	0.22	34.1	19.8	6.42	2.40	2.32	6.06
S 7x14.6	0.20	29.5	19.3	6.23	2.10	2.10	5.67
S 7x14.6	0.20	29.5	19.7	6.23	2.10	2.10	5.67
S 6x46.1	4.56	141	8.94	7.10	8.19	5.01	14.0
S 6x41	3.35	119	9.58	6.77	7.47	5.01	12.8
S 6x41	3.35	121	9.68	6.77	7.47	5.01	12.8
S 6x37.4	2.63	98.0	9.83	6.82	5.99	3.99	11.3
S 6x37.4	2.63	97.3	9.79	6.82	5.99	3.99	11.3
S 6x32.3	1.80	82.9	10.9	6.48	5.42	3.99	10.2
S 6x32.3	1.80	82.3	10.9	6.48	5.42	3.99	10.2
S 6x27.7	1.10	67.4	12.6	6.76	4.38	3.14	8.83
S 6x23.9	0.77	59.1	14.1	6.50	4.05	3.14	7.99
S 6x21.67	0.78	27.7	9.61	5.15	2.39	2.18	6.81
S 6x20	0.52	31.6	12.5	5.53	2.41	2.13	6.43
S 6x20	0.53	29.1	12.0	5.29	2.35	2.17	6.38
S 6x20	0.52	26.4	11.5	5.25	2.10	1.94	6.12
S 6x18.33	0.54	16.5	8.87	4.50	1.64	1.72	5.66
S 6x18	0.41	22.6	12.0	5.27	1.85	1.72	5.59
S 6x17.5	0.35	23.5	13.2	5.07	1.96	1.94	5.54
S 6x17.25	0.39	19.1	11.3	5.04	1.62	1.57	5.28
S 6x17.25	0.37	18.6	11.4	5.02	1.61	1.57	5.22
S 6x17.25	0.37	18.6	11.4	5.02	1.60	1.57	5.21
S 6x17.25	0.37	18.3	11.2	5.03	1.61	1.57	5.23
S 6x16.67	0.43	21.7	11.4	4.82	2.09	2.18	5.71
S 6x16.6	0.30	26.2	15.1	5.24	2.16	2.13	5.46
S 6x16.1	0.31	16.0	11.6	5.13	1.53	1.49	4.96
S 6x16	0.33	24.8	13.9	5.02	2.11	2.17	5.50
S 6x15.5	0.26	18.2	13.5	5.14	1.58	1.56	4.85
S 6x15.2	0.24	17.2	13.6	5.05	1.48	1.49	4.69
S 6x15	0.25	19.8	14.4	5.06	1.71	1.72	4.92
S 6x15	0.26	21.3	14.6	4.91	1.83	1.94	5.00
S 6x14.75	0.25	16.7	13.2	4.87	1.51	1.57	4.72
S 6x14.75	0.24	16.4	13.3	4.85	1.50	1.57	4.68
S 6x14.75	0.24	16.5	13.4	4.85	1.50	1.57	4.67
S 6x14.75	0.24	16.7	13.4	4.86	1.50	1.57	4.68
S 6x13.33	0.27	12.5	11.0	4.16	1.40	1.72	4.56
S 6x13	0.19	18.0	15.8	4.92	1.61	1.72	4.48
S 6x12.75	0.16	17.8	17.0	4.95	1.47	1.56	4.24

Table 2.3.2 Torsion Properties -- Steel Sections 1887-1952

Designation	Torsional Constant	Warping Constant	$(EC_w/GJ)^{1/2}$	Normalized Warping Constant	Warping Statical Moment	Statical Moment	Statical Moment
	J	C _w	a	W _{no}	S _w	Q _f	Q _w
	in.4	in.6	in.	in.2	in.4	in.3	in.3
S 6x12.5	0.17	14.7	15.1	4.70	1.40	1.57	4.17
S 6x12.5	0.17	14.3	14.9	4.70	1.40	1.57	4.17
S 6x12.27	0.17	14.7	15.0	4.70	1.41	1.57	4.18
S 6x12.25	0.17	15.1	15.3	4.70	1.40	1.57	4.17
S 6x12.25	0.17	14.6	15.0	4.70	1.41	1.57	4.18
S 6x12	0.14	15.3	17.0	4.79	1.36	1.50	3.99
S 6x11.9	0.14	14.7	16.8	4.82	1.35	1.49	3.97
S 6x11.6	0.14	14.9	16.8	4.82	1.35	1.49	3.97
S 5x17.33	0.47	13.4	8.63	3.86	1.42	1.42	4.46
S 5x16	0.43	11.6	8.34	3.69	1.31	1.37	4.27
S 5x16	0.37	12.4	9.31	3.77	1.36	1.42	4.22
S 5x15	0.34	9.8	8.58	3.84	1.06	1.09	3.78
S 5x15	0.32	11.7	9.79	3.71	1.31	1.42	4.04
S 5x14.75	0.34	9.28	8.46	3.85	1.03	1.06	3.70
S 5x14.75	0.32	9.17	8.64	3.83	1.03	1.06	3.66
S 5x14.75	0.32	9.12	8.63	3.83	1.02	1.06	3.65
S 5x14.75	0.32	9.28	8.62	3.84	1.03	1.06	3.67
S 5x14	0.27	9.14	9.29	3.77	1.02	1.09	3.60
S 5x13	0.23	10.4	10.7	3.57	1.22	1.42	3.66
S 5x13	0.26	9.5	9.66	3.49	1.17	1.37	3.72
S 5x13	0.23	7.04	8.90	3.51	0.92	1.05	3.34
S 5x12.5	0.20	6.68	9.34	3.76	0.90	0.99	3.22
S 5x12.3	0.17	7.62	10.6	3.72	0.89	0.99	3.13
S 5x12.25	0.19	7.92	10.4	3.68	0.94	1.06	3.24
S 5x12.25	0.18	7.76	10.7	3.66	0.93	1.06	3.18
S 5x12.25	0.18	7.81	10.7	3.66	0.93	1.06	3.19
S 5x12.25	0.18	7.64	10.4	3.67	0.94	1.06	3.21
S 5x12	0.17	8.05	11.0	3.64	0.95	1.09	3.23
S 5x12	0.17	7.87	11.0	3.66	0.93	1.06	3.18
S 5x10	0.12	7.02	12.5	3.50	0.88	1.09	2.86
S 5x10	0.11	6.72	12.4	3.51	0.86	1.06	2.78
S 5x10	0.12	7.58	12.5	3.31	0.81	1.05	2.80
S 5x10	0.11	6.55	12.2	3.51	0.86	1.06	2.78
S 5x9.75	0.11	7.05	13.1	3.51	0.85	1.06	2.78
S 5x9.75	0.11	6.61	12.4	3.51	0.85	1.06	2.78
S 5x9.75	0.11	6.55	12.2	3.51	0.86	1.06	2.78
S 5x9.4	0.09	6.30	13.5	3.53	0.79	0.99	2.60
S 5x9.1	0.09	6.19	13.4	3.53	0.79	0.99	2.60
S 4x13.33	0.30	5.21	6.74	2.70	0.79	0.88	2.73
S 4x13.33	0.29	5.17	6.82	2.68	0.79	0.89	2.71
S 4x11.46	0.20	4.40	7.55	2.61	0.70	0.85	2.45
S 4x11.3	0.22	3.10	6.10	2.59	0.60	0.72	2.32
S 4x10.67	0.17	3.48	7.19	2.74	0.59	0.68	2.22

Table 2.3.2 Torsion Properties -- Steel Sections 1887-1952

Designation	Torsional Constant	Warping Constant	$(EC_w/GJ)^{1/2}$	Normalized Warping Constant	Warping Statical Moment	Statical Moment	Statical Moment
	J	C _w	a	W _{no}	S _w	Q _f	Q _w
	in.4	in.6	in.	in.2	in.4	in.3	in.3
S 4x10.5	0.17	3.44	7.22	2.67	0.56	0.67	2.16
S 4x10.5	0.16	3.47	7.41	2.66	0.56	0.67	2.14
S 4x10.5	0.16	3.43	7.49	2.65	0.56	0.67	2.13
S 4x10.5	0.16	3.44	7.37	2.66	0.56	0.67	2.14
S 4x10.2	0.15	3.94	8.23	2.52	0.66	0.85	2.26
S 4x10	0.14	3.30	7.69	2.61	0.53	0.65	2.08
S 4x10	0.15	3.28	7.43	2.65	0.53	0.64	2.10
S 4x10	0.15	3.96	8.18	2.48	0.67	0.89	2.27
S 4x10	0.15	3.04	7.18	2.48	0.51	0.65	2.08
S 4x9.5	0.13	3.19	8.11	2.60	0.53	0.67	2.02
S 4x9.5	0.12	3.19	8.39	2.59	0.53	0.67	1.98
S 4x9.5	0.12	3.12	8.26	2.58	0.53	0.67	1.99
S 4x9.5	0.12	3.13	8.20	2.59	0.53	0.67	1.99
S 4x9.4	0.14	3.12	7.54	2.55	0.52	0.65	2.06
S 4x9	0.10	2.99	8.68	2.54	0.50	0.65	1.93
S 4x8.5	0.09	2.92	8.98	2.53	0.51	0.67	1.87
S 4x8.5	0.09	2.92	9.21	2.52	0.50	0.67	1.84
S 4x8.5	0.09	2.85	9.20	2.51	0.50	0.67	1.83
S 4x8.5	0.09	2.85	9.05	2.52	0.50	0.67	1.85
S 4x8.4	0.09	1.84	7.13	2.29	0.39	0.55	1.74
S 4x8.3	0.10	2.83	8.62	2.39	0.51	0.72	1.88
S 4x8	0.09	1.57	6.60	2.18	0.33	0.49	1.63
S 4x7.9	0.08	2.70	9.54	2.50	0.47	0.64	1.78
S 4x7.7	0.07	2.65	9.73	2.47	0.48	0.67	1.72
S 4x7.5	0.07	2.71	9.85	2.47	0.48	0.67	1.72
S 4x7.5	0.07	2.65	9.73	2.47	0.48	0.67	1.72
S 4x7.5	0.07	2.61	9.58	2.46	0.48	0.67	1.73
S 4x7.5	0.07	2.58	9.99	2.43	0.46	0.65	1.70
S 4x7.5	0.07	2.39	9.22	2.31	0.44	0.65	1.70
S 4x7	0.06	2.48	10.3	2.40	0.45	0.65	1.64
S 4x6.85	0.07	2.43	9.56	2.37	0.45	0.65	1.68
S 4x6.2	0.05	1.70	9.67	2.14	0.34	0.55	1.42
S 4x6	0.04	1.33	8.82	2.05	0.29	0.49	1.34
S 4x6	0.05	1.26	8.49	2.04	0.29	0.49	1.33
S 3.5x6	0.05	1.18	8.24	1.89	0.29	0.45	1.17
S 3.5x5.8	0.05	1.18	8.24	1.89	0.29	0.45	1.17
S 3x9.07	0.17	1.14	4.20	1.76	0.36	0.45	1.40
S 3x9	0.17	1.48	4.78	1.66	0.38	0.51	1.45
S 3x7.5	0.10	1.14	5.49	1.73	0.28	0.38	1.18
S 3x7.5	0.10	1.13	5.51	1.73	0.28	0.38	1.18
S 3x7.5	0.09	1.11	5.60	1.72	0.28	0.38	1.16
S 3x7.5	0.09	1.11	5.72	1.71	0.28	0.38	1.15
S 3x7.5	0.09	1.11	5.61	1.72	0.28	0.38	1.16

Table 2.3.2 Torsion Properties -- Steel Sections 1887-1952

Designation	Torsional Constant	Warping Constant	$(EC_w/GJ)^{1/2}$	Normalized Warping Constant	Warping Statical Moment	Statical Moment	Statical Moment
	J	C _w	a	W _{no}	S _w	Q _f	Q _w
	in.4	in.6	in.	in.2	in.4	in.3	in.3
S 3x7	0.10	1.13	5.54	1.53	0.32	0.51	1.22
S 3x7	0.08	1.00	5.64	1.60	0.27	0.40	1.13
S 3x6.93	0.08	0.80	5.18	1.61	0.25	0.37	1.10
S 3x6.83	0.08	1.03	5.86	1.61	0.30	0.45	1.16
S 3x6.83	0.08	0.94	5.57	1.61	0.25	0.37	1.09
S 3x6.5	0.06	0.99	6.33	1.66	0.26	0.38	1.07
S 3x6.5	0.06	0.99	6.39	1.66	0.26	0.38	1.07
S 3x6.5	0.06	0.98	6.51	1.65	0.26	0.38	1.05
S 3x6.5	0.06	0.96	6.57	1.64	0.26	0.38	1.04
S 3x6.5	0.06	0.96	6.43	1.65	0.26	0.38	1.05
S 3x6.3	0.06	0.76	5.73	1.45	0.22	0.36	1.00
S 3x6	0.06	0.87	6.31	1.53	0.25	0.40	1.02
S 3x5.7	0.04	0.86	7.11	1.60	0.24	0.38	0.96
S 3x5.7	0.04	0.86	7.11	1.60	0.24	0.38	0.96
S 3x5.5	0.04	0.86	7.11	1.60	0.24	0.38	0.96
S 3x5.5	0.04	0.86	7.11	1.60	0.24	0.38	0.96
S 3x5.5	0.04	0.84	7.04	1.60	0.24	0.38	0.96
S 3x5.3	0.04	0.63	6.15	1.38	0.20	0.36	0.89
S 3x5.3	0.04	0.75	6.69	1.50	0.22	0.37	0.92
S 3x5.3	0.04	0.75	6.88	1.50	0.22	0.37	0.92
S 3x5.2	0.04	0.63	6.15	1.38	0.20	0.36	0.89
S 3x5.1	0.04	0.65	6.28	1.38	0.20	0.36	0.89
CB362N	64.6	398023	126	146	1021	231	622
CB362	66.8	375258	121	142	987	230	622
36WF, CB362	64.7	376076	123	146	1021	231	622
36WF, B36a	66.8	376076	121	146	1021	231	622
G36	70.4	361495	115	146	1021	231	622
G36	58.2	329855	121	145	944	215	579
CB362N	52.9	365513	134	145	944	215	578
36WF, CB362	53.0	343917	130	145	944	215	578
36WF, B36a	54.9	343917	127	145	944	215	578
CB362	51.5	335087	130	141	889	208	566
36WF, CB362	42.1	308997	138	144	858	197	532
36WF, B36a	43.9	308997	135	144	858	197	532
G36	46.3	294797	128	144	858	197	532
CB362N	41.9	330160	143	144	858	197	532
G36	41.3	278726	132	144	819	188	510
CB362N	37.2	313816	148	144	818	188	510
CB362	38.5	295847	141	140	792	187	510
36WF, CB362	37.3	292545	143	144	818	188	509
36WF, B36a	39.0	292545	139	144	818	188	509
36WF, CB362	35.1	284540	145	143	798	184	498
36WF, B36a	36.7	284540	142	143	798	184	498
36WF, CB362	33.0	276652	147	143	779	180	488

Table 2.3.2 Torsion Properties -- Steel Sections 1887-1952

Designation	Torsional Constant	Warping Constant	$(EC_w/GJ)^{1/2}$	Normalized Warping Constant	Warping Statical Moment	Statical Moment	Statical Moment
	J	C _w	a	W _{no}	S _w	Q _f	Q _w
	in.4	in.6	in.	in.2	in.4	in.3	in.3
36WF, B36a	34.6	276652	144	143	779	180	488
CB362N	32.9	297639	153	143	779	180	488
G36	36.6	262640	136	143	779	180	488
G36	32.5	247290	140	143	740	171	467
36WF, CB362	29.0	260953	153	143	740	171	466
36 WF, B36a	30.6	260953	149	143	740	171	466
G36	32.3	247050	141	143	740	171	466
CB362	30.0	265715	152	139	716	170	466
CB362N	28.9	281718	159	143	740	171	465
36WF, CB361	22.5	110214	113	107	407	126	380
36WF, B36	23.2	110214	111	107	407	126	380
CB361	22.6	118093	116	107	410	127	378
B36	24.0	106863	107	107	410	127	378
CB361N	22.3	117010	117	107	410	127	378
B36	23.7	107128	108	107	411	128	376
36WF, CB361	18.6	101163	119	106	378	118	355
36WF, B36	19.3	101163	117	106	378	118	355
B36	18.4	93567	115	106	366	114	343
CB361N	16.9	103549	126	106	366	114	343
CB361	17.0	104141	126	107	365	114	341
B36	17.7	92808	116	106	363	114	339
36WF, CB361	15.2	92375	125	105	349	109	330
36WF, B36	15.8	92375	123	105	349	109	330
B36	15.7	86652	119	105	343	108	324
CB361N	14.4	96567	132	105	342	108	324
B36	15.0	85801	122	105	340	107	319
36WF, CB361	12.5	84245	132	105	321	101	308
36WF, B36	13.1	84245	129	105	321	101	308
CB361	13.0	92639	136	106	327	103	310
CB361N	12.3	90118	138	105	321	101	306
B36	13.4	80268	125	105	321	101	306
B36	12.9	79540	127	105	319	101	301
36WF, B36	10.7	76247	136	104	294	93.1	286
36WF, CB361	10.2	76247	139	104	294	93.1	286
CB361N	10.4	83956	144	105	300	95.2	288
B36	11.5	74201	130	105	300	95.2	289
B36	11.0	73472	132	105	298	94.6	284
CB361N	10.1	82967	146	105	295	93.5	283
B36	11.1	74247	132	105	301	95.7	285
G33	52.8	241793	109	127	785	187	497
CB332	46.8	277998	124	130	799	187	498

Table 2.3.2 Torsion Properties -- Steel Sections 1887-1952

Designation	Torsional Constant	Warping Constant	$(EC_w/GJ)^{1/2}$	Normalized Warping Constant	Warping Statical Moment	Statical Moment	Statical Moment
	J	C _w	a	W _{no}	S _w	Q _f	Q _w
	in.4	in.6	in.	in.2	in.4	in.3	in.3
CB332N	46.5	266908	122	128	779	185	496
G33	51.5	241050	110	128	778	185	496
G33	44.4	222307	114	127	731	175	466
G33	40.8	215098	117	127	707	169	455
CB332	36.9	251260	133	129	727	172	457
CB332N	36.5	240498	131	127	707	169	455
33WF	38.5	225222	123	127	707	169	454
33WF	36.9	225222	126	127	707	169	454
G33	37.0	203293	119	126	678	163	435
G33	31.7	190013	125	126	637	153	414
G33	32.4	190463	123	126	641	155	414
33WF, CB332	28.4	199982	135	126	637	153	414
33WF	29.9	199982	132	126	637	153	414
CB332	28.1	222866	143	128	650	154	415
CB332N	28.0	214909	141	126	637	153	414
G33	28.4	178722	128	125	608	147	395
33WF	26.0	187256	137	126	601	145	393
33WF	24.7	187256	140	126	601	145	393
G33	27.5	177226	129	126	601	145	393
CB332N	24.3	202122	147	126	601	145	393
G33	25.1	167694	131	125	576	140	377
G33	24.0	165579	134	125	568	138	373
G33	24.7	167015	132	125	575	140	374
CB332	20.8	195450	156	127	574	137	372
CB332N	21.0	190179	153	125	568	138	373
33WF, CB332	21.3	175419	146	125	568	138	373
33WF	22.6	175419	142	125	568	138	373
CB331	15.3	84597	120	98.9	320	99	299
B33	18.1	69291	99.5	91.7	310	103	301
33WF, CB331	12.5	67398	118	93.8	286	94	276
33WF, B33	12.9	67398	116	93.8	286	93.5	276
CB331N	12.4	71793	123	93.8	286	93.5	276
CB331	11.7	75409	129	98.1	287	89.8	271
B33	13.8	60340	106	91.1	275	91.4	273
B33	13.6	64503	111	93.8	286	93.5	276
B33	13.9	60870	106	91.0	277	92.3	273
B33	11.6	55479	111	90.6	256	85.7	256
33WF	10.2	60097	123	93.3	258	84.9	254
33WF, CB331	9.80	60097	126	93.3	258	84.9	254
B33	10.7	57219	117	93.3	258	84.9	254
CB331N	9.70	64413	131	93.3	258	84.9	254
CB331	8.91	67099	140	97.3	258	81.3	245
B33	9.73	51058	117	90.2	238	80.4	240
33WF	8.31	54098	130	92.9	235	77.6	235

Table 2.3.2 Torsion Properties -- Steel Sections 1887-1952

Designation	Torsional Constant	Warping Constant	$(EC_w/GJ)1/2=$	Normalized Warping Constant	Warping Statical Moment	Statical Moment	Statical Moment
	J	Cw	a	Wno	Sw	Qf	Qw
	in.4	in.6	in.	in.2	in.4	in.3	in.3
33WF	7.90	54098	133	92.9	235	77.6	235
CB33N	7.82	58394	139	92.9	235	77.6	235
B33	8.70	51235	123	92.9	235	77.6	235
33WF	7.46	52351	135	92.8	228	75.3	230
33WF, B33	7.86	52351	131	92.8	228	75.3	230
B33	8.03	46669	123	89.7	221	75.1	223
B33	8.07	46914	123	89.7	222	75.6	223
33WF, B33	6.91	48768	135	92.6	214	70.8	219
33WF, CB331	6.53	48768	139	92.6	214	70.8	219
CB331	6.75	59655	151	96.6	231	73.5	221
B33	7.23	45918	128	92.6	214	70.8	219
CB331N	6.45	53018	146	92.6	214	70.8	219
G30	46.4	166635	96.4	111	635	157	419
CB302N	42.1	188416	108	111	634	157	419
CB302N	47.4	163293	94.5	104	589	155	416
G30	46.3	170792	97.8	111	634	157	418
G30	36.4	151835	104	110	574	144	382
G30	36.2	151691	104	110	574	143	382
CB302N	32.7	168932	116	110	574	143	381
CB302N	36.9	146441	101	103	533	142	379
30WF	30.0	149504	114	110	545	137	363
30WF	28.8	149504	116	110	545	137	363
G30	27.8	133318	112	109	515	130	345
G30	27.6	133172	112	109	515	130	345
G30	31.0	123703	102	108	515	131	345
CB302N	24.7	150140	125	109	515	130	345
CB302N	28.1	130246	109	102	479	129	343
30WF, CB302	24.9	139963	121	109	515	130	344
30WF	26.0	139963	118	109	515	130	344
G30	29.1	130039	108	108	513	130	344
G30	27.8	131028	111	109	509	129	343
30WF, B30a	22.5	130734	123	109	485	123	326
30WF, CB302	21.4	130734	126	109	485	123	326
G30	23.9	124036	116	109	485	123	327
CB302N	21.2	140760	131	109	485	123	326
G30	23.8	123890	116	109	484	123	326
G30	24.1	122324	115	108	481	122	325
G30	20.9	114046	119	108	454	116	308
G30	20.8	115686	120	108	458	117	310
G30	26.3	89152	93.7	93.2	398	116	309
G30	20.6	115414	121	108	457	116	309
CB302N	18.2	132089	137	108	457	116	309
CB302N	20.8	114556	119	101	426	116	307

Table 2.3.2 Torsion Properties -- Steel Sections 1887-1952

Designation	Torsional Constant	Warping Constant	$(EC_w/GJ)^{1/2}$	Normalized Warping Constant	Warping Statical Moment	Statical Moment	Statical Moment
	J	C _w	a	W _{no}	S _w	Q _f	Q _w
	in.4	in.6	in.	in.2	in.4	in.3	in.3
30WF, CB302	18.3	122063	131	108	457	116	308
30WF, CB302	19.3	122063	128	108	457	116	308
G30	27.6	70999	81.6	85.9	352	111	298
G30	18.1	105773	123	107	426	109	292
G30	18.1	107734	124	108	431	110	294
30WF, B30a	16.9	114188	132	108	431	110	293
30WF, CB302	15.9	114188	136	108	431	110	293
CB301	18.9	56241	87.8	79.1	266	92.1	273
B30	20.4	51739	81.1	78.4	266	93.0	272
CB301	14.7	50391	94.4	78.3	240	84.3	249
B30	15.8	45950	86.7	77.7	241	85.0	248
CB301	11.3	45061	101.6	77.6	217	76.9	227
B30	12.4	40991	92.4	77.1	219	77.8	227
CB301	10.6	43856	104	77.5	212	75.2	222
30WF, B30	10.2	39705	101	77.3	204	72.8	216
30WF, CB301	9.8	39705	102	77.3	204	72.8	216
CB302N	9.7	42317	106	77.3	205	73.2	216
B30	10.6	38194	96.8	77.3	205	73.2	215
B30	10.4	37631	97.0	76.6	203	73.0	212
B30	10.4	37622	97.0	76.7	203	73.0	212
CB301	8.67	40284	110	77.0	196	70.1	206
CB301	8.48	39924	110	77.0	194	69.6	205
30WF, B30	8.41	36248	106	76.9	188	67.5	202
30WF, CB301	8.08	36248	108	76.9	188	67.5	202
B30	8.36	33788	102	76.9	184	66.1	198
CB301N	7.58	37819	114	76.9	184	66.1	198
B30	8.73	34669	101	76.3	190	68.5	199
B30	8.73	34669	101	76.3	190	68.5	199
B30	8.93	34789	100	76.2	192	69.3	199
B30	8.93	34789	100	76.2	192	69.3	199
B30	10.3	31395	88.8	72.4	188	71.1	201
30WF, B30	6.81	32544	111	76.5	171	61.5	187
30WF, CB301	6.50	32544	114	76.5	171	61.5	187
B30	7.02	30930	107	76.5	171	61.6	186
CB301N	6.33	34945	120	76.5	171	61.6	186
CB301	6.67	36161	118	76.4	177	64.0	188
B30	7.39	31899	106	76.0	177	64.0	187
B30	7.39	31899	106	76.0	177	64.0	187
B30	6.45	29695	109	75.8	166	60.3	178
B30	5.84	28116	112	76.2	158	57.1	173
CB301N	5.22	32072	126	76.2	158	57.1	173
30WF	5.36	28522	117	76.2	152	54.9	171
30WF, CB301	5.09	28522	120	76.2	152	54.9	171

Table 2.3.2 Torsion Properties -- Steel Sections 1887-1952

Designation	Torsional Constant	Warping Constant	$(EC_w/GJ)^{1/2}$	Normalized Warping Constant	Warping Statical Moment	Statical Moment	Statical Moment
	J	C _w	a	W _{no}	S _w	Q _f	Q _w
	in.4	in.6	in.	in.2	in.4	in.3	in.3
G28	25.1	98886	101	96.8	429	114	301
G28a	25.9	90927	95.3	96.0	424	113	293
G28a	24.4	95563	101	96.0	423	112	292
G28	20.6	89351	106	96.3	393	105	279
G28	20.8	90212	106	96.3	397	106	280
G28	17.7	83012	110	95.9	370	98.9	264
G28	17.7	83012	110	95.9	370	98.9	264
G28	22.5	66447	87.5	83.5	331	100	265
G28	17.8	83765	110	95.9	373	99.9	265
G28	23.9	58473	79.6	80.1	313	98.8	261
G28	15.2	77572	115	95.4	350	94.2	249
G28	15.0	76710	115	95.4	347	93.2	248
G28	12.8	71118	120	95.0	326	88.1	233
G28	12.4	69951	121	94.8	322	87.1	231
B28	12.4	33137	83.2	69.8	194	71.6	208
B28	9.20	28832	90.1	69.1	172	64.4	186
B28	7.92	26286	92.7	68.2	160	60.5	174
B28	8.59	26276	89.0	68.7	167	62.9	179
B28	6.59	24073	97.2	67.8	149	56.5	163
B28	6.75	24164	96.3	67.8	151	57.2	163
B28	7.97	22402	85.3	64.9	150	59.5	166
B28	6.75	24164	96.3	67.8	151	57.2	163
B28	6.21	23914	99.8	68.4	147	55.7	161
B28	5.50	22008	102	67.5	138	52.5	153
B28	5.09	21718	105	68.0	136	51.7	149
B28	4.32	19683	109	67.1	125	48.0	139
B28	4.18	19652	110	67.7	125	47.7	139
B28	3.17	16646	117	67.5	108	41.3	126
CB272	25.1	105716	104	93.3	424	113	299
27WF, CB272	20.3	88505	106	92.0	386	104	275
27WF, B27a	21.2	88505	104	92.0	386	104	275
CB272	19.8	95628	112	92.5	387	104	274
CB272N	20.4	97349	111	92.4	394	107	276
CB272N	17.5	91270	116	92.0	372	101	261
27WF, CB272	15.9	79363	114	91.3	351	95.2	252
27WF, B27A	16.7	79363	111	91.3	351	95.2	252
CB272	15.3	85795	120	91.8	350	95.1	249
27WF, CB272	15.1	77432	115	91.2	344	93.4	247
27WF, B27a	15.9	77432	112	91.2	344	93.4	247
CB272N	14.7	84729	122	91.5	347	94.7	245
27WF, CB272	13.5	73755	119	90.9	329	89.8	237
27WF, B27a	14.3	73755	116	90.9	329	89.8	237
27WF, B27a	12.1	68264	121	90.4	308	84.4	223
27WF, CB272	11.4	68264	125	90.4	308	84.4	223

Table 2.3.2 Torsion Properties -- Steel Sections 1887-1952

Designation	Torsional Constant	Warping Constant	$(EC_w/GJ)1/2=$	Normalized Warping Constant	Warping Statical Moment	Statical Moment	Statical Moment
	J	C _w	a	W _{no}	S _w	Q _f	Q _w
	in.4	in.6	in.	in.2	in.4	in.3	in.3
CB272N	11.5	76307	131	91.1	314	86.0	225
CB271	12.8	33136	81.7	66.4	186	69.6	205
CB271	9.64	29295	88.7	65.7	167	63.0	185
27WF, CB271	7.43	25964	95.1	66.3	156	58.3	170
27WF	7.71	25964	93.4	66.3	156	58.3	170
CB271N	7.37	28763	101	67.1	160	60.3	171
CB271	7.18	25817	96.5	65.1	148	56.7	166
27WF, CB271	5.97	23495	101	65.9	143	53.8	157
27WF, B27	6.23	23495	98.8	65.9	143	53.8	157
CB27N	5.96	26327	107	66.7	148	56.0	158
27WF, CB271	5.32	22297	104	65.7	136	51.5	151
27WF, B27	5.57	22297	102	65.7	136	51.5	151
CB271	5.34	22822	105	64.5	132	51.2	150
27WF, CB27	4.71	21104	108	65.5	130	49.3	144
27WF, B27	4.95	21104	105	65.5	130	49.3	144
CB271N	4.84	24149	114	66.3	136	52.0	147
27WF, CB271	4.10	19697	112	65.3	122	46.4	137
27WF, B27	4.33	19697	109	65.3	122	46.4	137
27WF, B27	3.85	18603	112	64.2	112	43.5	130
27WF, CB271	3.67	18603	115	65.2	116	44.2	132
CB271N	3.80	21574	121	66.1	122	46.6	135
CB271	3.94	20130	115	64.0	118	46.0	134
B61	3.93	13014	92.6	59.2	94.2	39.4	127
CB271N	2.97	19065	129	65.9	108	41.4	124
CB271	3.04	17615	122	63.8	103	40.4	122
B31	5.11	9050	67.7	49.0	81.7	41.1	121
G26	21.4	78159	97.3	88.7	371	100	260
G26	18.0	67633	98.6	86.2	332	91.7	241
G26a	21.0	63834	88.7	84.4	339	95.0	243
G26a	19.8	67118	93.7	84.4	338	94.7	243
G26	18.0	67633	98.6	86.2	332	91.7	241
G26	16.8	69712	104	88.1	338	91.9	238
G26	15.4	62643	103	85.7	312	86.6	226
G26	15.4	62628	103	85.7	312	86.6	226
G26	20.1	47012	77.8	74.3	274	86.7	226
G26	18.8	48326	81.6	74.4	270	85.4	224
G26	13.3	61840	110	87.5	306	83.6	217
G26	13.2	58040	107	85.4	293	81.5	214
G26	13.2	58040	107	85.4	293	81.5	214
G26	11.9	55160	110	85.1	281	78.5	205
B26	6.28	18705	87.8	60.8	128	50.6	146
B26	5.74	17652	89.2	60.2	122	48.7	140
B26	5.74	17652	89.2	60.2	122	48.7	140

Table 2.3.2 Torsion Properties -- Steel Sections 1887-1952

Designation	Torsional Constant	Warping Constant	$(EC_w/GJ)1/2=$	Normalized Warping Constant	Warping Statical Moment	Statical Moment	Statical Moment
	J	Cw	a	Wno	Sw	Qf	Qw
	in.4	in.6	in.	in.2	in.4	in.3	in.3
B26	4.63	16111	94.9	60.3	113	45.0	131
B26	4.69	16027	94.0	59.9	113	45.2	130
B26	4.69	16027	94.0	59.9	113	45.2	130
B26	4.80	16062	93.1	59.8	114	45.8	130
B26	5.69	14744	81.9	57.5	115	47.7	133
B26	4.80	16062	93.1	59.8	114	45.8	130
B26	3.85	14497	98.8	59.6	104	41.6	121
B26	3.85	14481	98.7	59.6	104	41.6	121
B26	3.77	14533	100	60.0	103	41.5	121
B26	3.27	13274	103	59.4	96.1	38.7	114
CB244	16.4	72899	107	83.1	328	88.6	228
CB244N	16.5	73067	107	83.1	329	89.0	229
24WF, CB244	16.5	68502	104	83.1	332	89.9	230
24WF, B24b	17.4	68502	101	83.1	332	89.9	230
G24a	18.4	64811	95.4	83.1	331	89.6	230
G24a	15.2	58873	100	82.7	305	83.0	214
CB244N	13.5	67234	113	82.7	305	82.7	213
24WF, CB243	13.5	62500	110	82.6	307	83.3	214
24WF, B24b	14.3	62500	106	82.6	307	83.3	214
CB244	13.6	67416	113	82.6	306	82.9	213
G24a	16.3	50764	89.8	76.5	280	80.3	208
G24a	16.2	50658	90.1	76.4	280	80.3	207
24WF, 24b	13.0	59808	109	82.4	295	80.4	206
24WF, CB243	12.2	59808	113	82.4	295	80.4	206
G24a	13.8	46956	93.7	76.0	263	75.7	195
G24a	12.5	53295	105	82.2	281	76.8	198
24WF, B24b	11.7	56886	112	82.2	282	77.1	198
24WF, CB243	10.9	56886	116	82.2	282	77.1	198
CB244	11.1	62062	120	82.2	283	77.2	198
G24a	14.7	45563	89.5	74.5	261	76.7	197
CB244N	11.0	61392	120	82.2	280	76.3	197
G24a	13.7	46850	94.0	76.0	262	75.7	195
G24a	16.2	44317	84.1	74.4	268	79.0	198
G24a	11.8	43342	97.7	75.7	246	71.2	184
G24a	11.7	43237	98.0	75.6	246	71.2	183
CB244	8.98	56849	128	81.7	261	71.6	183
G24a	10.0	47573	111	81.7	256	70.3	182
24WF, B24B	9.36	51142	119	81.7	257	70.6	183
24WF, CB243	8.67	51142	124	81.7	257	70.6	183
CB244N	8.73	55705	129	81.8	255	70.0	182
G24	11.7	37132	90.8	71.0	221	68.6	179
G24	11.6	37038	91.1	70.9	221	68.6	179
G24	9.76	34111	95.1	70.6	206	64.4	168

Table 2.3.2 Torsion Properties -- Steel Sections 1887-1952

Designation	Torsional Constant	Warping Constant	$(EC_w/GJ)_{1/2}$	Normalized Warping Constant	Warping Statical Moment	Statical Moment	Statical Moment
	J	C _w	a	W _{no}	S _w	Q _f	Q _w
	in.4	in.6	in.	in.2	in.4	in.3	in.3
G24	10.5	46256	107	69.0	205	65.2	169
G24	9.67	34031	95.5	70.5	206	64.4	167
G24	9.28	32879	95.8	70.7	199	62.7	167
G24	11.4	31729	85.0	69.0	208	66.3	169
CB243	8.58	37924	107	70.6	201	63.6	167
24WF, CB242	8.27	34711	104	70.7	199	62.7	166
24WF, B24a	8.69	34711	102	70.7	199	62.7	166
CB243N	8.33	37182	108	70.7	197	62.2	166
G24	8.15	31265	99.7	70.2	192	60.2	157
G24	8.07	31186	100	70.2	191	60.2	156
24WF, B24a	6.83	31107	109	70.2	181	57.4	152
24WF, CB242	6.45	31107	112	70.2	181	57.4	152
CB243N	6.50	33547	116	70.2	179	56.9	151
CB243	6.69	34203	115	70.1	183	58.2	152
G24	7.28	29274	102	70.1	181	57.4	152
G24	7.04	29012	103	70.0	180	56.7	148
G24	6.96	28933	104	69.9	180	56.7	148
B24b	7.70	17803	77.4	56.6	130	50.3	140
G24b	7.70	17803	77.4	56.6	130	50.3	140
G24	5.58	25662	109	69.7	162	51.9	138
24WF, B24a	5.21	27442	117	69.7	162	51.9	137
24WF, CB242	4.88	27442	121	69.7	162	51.9	137
CB243	5.09	30566	125	69.6	164	52.8	138
CB243N	4.92	29849	125	69.7	160	51.4	137
B24b	6.70	16666	80.3	56.3	123	47.8	133
B24b	6.70	16653	80.2	56.3	123	47.8	133
B24b	5.83	15565	83.2	56.1	116	45.3	127
B24b	5.83	15565	83.2	56.1	116	45.3	127
CB242	4.81	17962	98.3	57.8	116	44.8	127
24WF, CB241	5.27	14012	83.0	53.0	105	43.6	125
24WF, B24	5.44	14012	81.6	53.0	105	43.6	125
B24a	5.12	16518	91.4	58.9	119	45.1	126
CB242N	4.62	18765	102.6	58.8	119	45.3	126
B24a	4.99	14239	85.9	55.4	108	43.1	121
24WF, B24	4.36	12666	86.7	52.7	95.9	40.3	116
24WF, CB241	4.20	12666	88.3	52.7	95.9	40.3	116
B24a	3.97	14615	97.7	58.5	107	41.1	114
CB242	3.60	15926	107	57.3	104	40.5	114
CB242N	3.48	16644	111	58.4	107	40.7	114
B24a	4.14	12937	90.0	55.2	99.4	39.8	113
B24a	4.36	12277	85.4	53.7	97.2	39.9	113
B24a	4.14	12937	90.0	55.2	99.4	39.8	113
B24a	4.36	12277	85.4	53.7	97.2	39.9	113
B24a	4.97	11003	75.7	51.3	94.4	40.5	113

Table 2.3.2 Torsion Properties -- Steel Sections 1887-1952

Designation	Torsional Constant	Warping Constant	$(EC_w/GJ)_{1/2}$	Normalized Warping Constant	Warping Statical Moment	Statical Moment	Statical Moment
	J	C _w	a	W _{no}	S _w	Q _f	Q _w
	in.4	in.6	in.	in.2	in.4	in.3	in.3
24WF, B24	3.90	12003	89.2	52.6	91.4	38.5	111
24WF, CB241	3.75	12003	91.0	52.6	91.4	38.5	111
B24	3.79	10583	85.0	53.2	85.4	35.3	108
B24	4.10	9616	77.9	51.3	83.9	35.9	108
B24	3.69	11055	88.1	52.8	88.4	37.1	107
CB241N	3.35	12477	98.2	52.8	88.4	37.1	107
24WF, CB241	3.21	11158	94.9	52.4	85.7	36.1	105
24WF, B24	3.35	11158	92.8	52.4	85.7	36.1	105
B24	3.60	11064	89.2	52.7	88.7	37.4	106
B24	3.60	11064	89.2	52.7	88.7	37.4	106
24WF, B24	2.86	10319	96.6	52.2	79.9	33.8	99.1
24WF, CB241	2.73	10319	99.0	52.2	79.9	33.8	99.1
CB242	2.61	13969	118	56.9	91.9	36.1	101.5
B62	2.49	8382	93.3	52.7	70.3	29.6	93.5
B24	2.88	9843	94.0	52.5	80.3	34.0	97.9
CB241N	2.59	11257	106	52.5	80.3	34.0	97.8
24WF, CB241	2.51	9937	101	52.1	77.3	32.8	96.3
24WF, B24	2.64	9937	98.7	52.1	77.3	32.8	96.3
B62	2.49	8382	93.3	52.7	70.3	29.6	93.5
B24	2.97	10139	94.0	52.4	82.5	35.1	98.6
B24	2.97	10139	94.0	52.4	82.5	35.1	98.6
B24	3.02	10095	93.0	52.4	83.0	35.3	98.6
B24	3.36	9156	84.1	50.6	81.5	35.9	98.4
B20	2.82	4618	65.1	40.8	48.9	26.0	86.6
B24	2.36	8792	98.2	52.3	72.9	31.0	91.1
CB241N	2.11	10198	112	52.3	72.9	31.0	91.0
CB241	2.34	9258	101	49.6	69.9	31.3	91.5
B24	2.45	9101	98.1	52.3	75.2	32.0	92.1
B32	3.66	5281	61.1	40.6	57.9	31.2	90.6
G22	12.7	38665	88.7	69.9	236	68.8	174
G22	10.6	35406	92.9	69.5	219	64.3	162
G22	8.49	31478	98.0	69.2	198	58.4	150
G22	8.74	32196	97.6	69.1	203	59.8	151
G22	7.24	29316	102	68.8	188	55.6	140
G22	6.98	28564	103	68.8	183	54.3	139
G22	5.73	25793	108	68.5	169	50.2	129
G22	5.93	26501	108	68.4	173	51.5	130
B22a	6.93	13071	69.9	49.7	108	43.9	120
B22a	6.56	12609	70.6	49.7	105	42.4	118
B22a	5.61	11829	73.9	49.3	99.7	40.7	111
B22a	5.32	11400	74.5	49.4	96.2	39.2	110
B22a	4.59	10752	77.8	49.0	92.0	37.8	103
B22a	4.34	10323	78.5	49.1	88.5	36.3	102

Table 2.3.2 Torsion Properties -- Steel Sections 1887-1952

Designation	Torsional Constant	Warping Constant	$(EC_w/GJ)^{1/2}$	Normalized Warping Constant	Warping Statical Moment	Statical Moment	Statical Moment
	J	C _w	a	W _{no}	S _w	Q _f	Q _w
	in.4	in.6	in.	in.2	in.4	in.3	in.3
B22a	3.71	9709	82.3	48.7	84.4	34.9	95.3
B22a	3.52	9340	82.9	48.8	81.4	33.6	93.9
B22	3.12	7792	80.4	46.3	70.9	31.4	90.1
B22	3.30	7990	79.2	45.9	73.0	32.5	90.7
B22	3.03	7538	80.3	45.7	69.6	31.0	87.7
B22	2.69	7117	82.7	45.5	66.3	29.7	84.0
B22	2.59	7103	84.3	45.7	66.1	29.6	83.0
B22	2.42	6882	85.8	46.0	63.8	28.5	82.1
B22	2.36	6698	85.7	45.4	63.0	28.3	79.9
B22	2.05	6309	89.3	45.4	59.8	26.9	76.2
B22	1.88	6006	91.0	45.8	57.0	25.6	74.7
B22	1.62	5557	94.1	45.3	53.7	24.2	70.0
B22	1.62	5487	93.6	45.0	53.3	24.1	69.6
B22	1.51	5257	95.0	45.6	50.9	22.9	68.8
B22	1.28	4767	98.2	45.1	47.3	21.3	64.0
21WF, B21b	14.6	40011	84.2	66.9	240	69.5	177
21WF, CB213	13.9	40011	86.4	66.9	240	69.5	177
CB213	12.6	41920	92.9	67.1	234	67.9	171
21WF, CB213	11.2	36413	91.6	66.4	222	64.5	164
21WF, B21b	11.9	36413	89.0	66.4	222	64.5	164
CB213	10.6	38998	97.7	66.7	219	63.9	160
21WF, CB213	10.1	34729	94.4	66.1	213	62.2	158
21WF, B21b	10.7	34729	91.7	66.1	213	62.2	158
21WF, B21b	9.53	32906	94.6	65.9	203	59.6	151
21WF, CB213	8.94	32906	97.6	65.9	203	59.6	151
CB213	8.77	36059	103	66.4	204	59.8	150
CB213N	8.04	35166	106	66.4	198	58.4	145
CB213	7.19	33239	109	66.0	189	55.7	139
21WF, CB213	6.94	29362	105	65.4	184	54.3	138
21WF, B21b	7.46	29362	101	65.4	184	54.3	138
CB213N	6.53	32294	113	66.0	183	54.2	135
CB213	5.80	30425	117	65.6	174	51.6	129
21WF, CB212	8.16	12328	62.6	46.0	105	43.3	121
21WF, B21a	8.27	12328	62.1	46.0	105	43.3	121
CB213N	5.32	29636	120	65.7	169	50.2	125
CB212	7.50	12959	66.9	46.3	105	43.3	117
CB212N	7.03	12741	68.5	46.4	103	42.5	115
21WF, CB212	6.59	11155	66.2	45.7	96.4	40.0	112
21WF, B21a	6.71	11155	65.6	45.7	96.4	40.0	112
CB213	6.27	11987	70.4	46.0	97.5	40.6	110
CB212N	5.68	11622	72.8	46.1	94.3	39.4	106
21WF, CB212	5.28	10075	70.3	45.3	88.2	36.8	103
21WF, CB21a	5.39	10075	69.6	45.3	88.2	36.8	103

Table 2.3.2 Torsion Properties -- Steel Sections 1887-1952

Designation	Torsional Constant	Warping Constant	(EC_w/GJ) ^{1/2} =	Normalized Warping Constant	Warping Statical Moment	Statical Moment	Statical Moment
	J	C _w	a	W _{no}	S _w	Q _f	Q _w
	in.4	in.6	in.	in.2	in.4	in.3	in.3
CB212	5.17	11035	74.3	45.7	90.3	37.9	102
CB212N	4.66	10681	77.0	45.8	87.3	36.7	98.6
21WF, CB212	4.16	9018	75.0	45.0	80.1	33.7	94.6
21WF, B21a	4.26	9018	74.1	45.0	80.1	33.7	94.6
CB212	4.22	10104	78.8	45.4	83.3	35.2	94.6
CB212N	3.76	9738	81.9	45.5	80.1	34.0	91.1
CB211	3.59	7484	73.5	41.7	67.1	31.2	89.1
B21	4.13	4266	51.7	35.3	50.7	26.8	82.3
CB211N	3.22	7845	79.4	42.8	68.5	31.2	86.8
21WF, CB211	3.06	6955	76.7	42.5	65.2	29.7	85.1
21WF, B21a	3.18	6955	75.3	42.5	65.2	29.7	85.1
CB211	2.84	6766	78.6	41.4	61.2	28.7	81.8
21WF, CB211	2.48	6312	81.2	42.3	59.9	27.4	78.9
21WF, B21	2.59	6312	79.5	42.3	59.9	27.4	78.9
CB211N	2.52	7073	85.3	42.5	62.3	28.6	79.4
CB211	2.19	6088	84.8	41.1	55.4	26.2	74.5
21WF, CB211	1.93	5586	86.6	42.0	53.8	24.8	72.1
21WF	2.03	5586	84.4	42.0	53.8	24.8	72.1
CB211N	2.00	6418	91.3	42.3	56.9	26.3	73.0
21WF, CB211	1.86	5511	87.7	42.0	53.2	24.6	71.1
21WF, CB21	1.96	5511	85.4	42.0	53.2	24.6	71.1
B63	1.71	4549	82.9	42.2	47.6	21.9	67.4
B63	1.71	4549	82.9	42.2	47.6	21.9	67.4
CB211	1.80	4551	80.8	40.9	51.2	24.4	69.5
21WF, CB211	1.58	5086	91.3	41.8	49.5	22.9	67.1
21WF, B21	1.68	5086	88.6	41.8	49.5	22.9	67.1
CB211N	1.62	5867	96.8	42.1	52.2	24.3	67.8
CB211	1.65	5406	92.1	40.8	49.6	23.7	67.2
B22	1.89	2544	59.1	33.1	33.4	19.2	62.1
B33	2.55	2914	54.4	32.9	39.6	23.0	65.7
CB211	1.35	4891	97.0	40.7	45.0	21.5	62.6
----	1.26	4523	96.5	41.6	44.6	20.7	61.8
G20a	20.2	34337	66.3	60.4	236	69.8	175
G20a	20.2	34328	66.3	60.4	236	69.8	175
G20	19.8	30434	63.1	57.8	216	67.5	172
CB203N	18.0	33419	69.3	57.8	216	67.5	172
G20a	17.6	32025	68.7	60.0	222	66.2	165
G20a	17.6	32016	68.7	60.0	222	66.2	165
G20a	19.5	29537	62.6	58.7	220	66.9	166
G20a	18.4	30839	65.8	58.8	220	66.7	165
G20	15.7	27162	66.8	57.3	197	61.7	158
CB203N	14.2	30089	74.1	57.3	197	61.7	157
G20a	15.1	29768	71.3	59.7	209	62.6	156

Table 2.3.2 Torsion Properties -- Steel Sections 1887-1952

Designation	Torsional Constant	Warping Constant	$(EC_w/GJ)1/2=$	Normalized Warping Constant	Warping Statical Moment	Statical Moment	Statical Moment
	J	C _w	a	W _{no}	S _w	Q _f	Q _w
	in.4	in.6	in.	in.2	in.4	in.3	in.3
G20a	15.1	29759	71.3	59.7	209	62.6	156
G20a	12.8	27400	74.4	59.4	195	58.7	147
G20	12.6	24293	70.8	56.9	179	56.6	145
CB203N	11.4	27184	78.4	56.9	179	56.5	145
G20	11.1	23759	74.4	57.5	174	55.1	140
G20	11.1	23750	74.4	57.5	174	55.1	140
CB203N	8.75	24383	84.9	56.4	162	51.5	132
G20	9.85	21529	75.2	56.4	162	51.5	132
G20	9.38	21850	77.7	57.2	163	51.7	131
G20	9.38	21850	77.7	57.2	163	51.7	131
G20	10.5	21057	71.9	57.1	168	53.4	133
G20	9.50	21705	76.9	57.1	163	51.9	131
G20	7.91	20054	81.0	56.9	151	48.3	123
G20	7.91	20045	81.0	56.9	151	48.3	123
G20	6.46	18099	85.2	56.5	139	44.6	114
B20a	8.01	10725	58.9	44.1	99.2	40.9	112
CB202N	7.33	11683	64.2	44.1	99.2	40.9	112
CB202N	5.36	10205	70.2	43.6	87.6	36.5	99.6
B20A	5.88	9247	63.8	43.6	87.6	36.5	99.6
B20a	5.07	6584	58.0	40.8	70.2	30.8	90.1
B20a	4.58	7389	64.6	42.7	72.9	30.7	89.9
B20a	4.43	8036	68.6	43.2	77.8	32.7	89.6
CB202N	4.00	8976	76.2	43.2	77.8	32.7	89.6
B20a	4.22	7869	69.5	42.9	76.6	32.6	88.4
CB202N	3.19	8160	81.4	42.9	71.2	30.2	82.6
B20a	3.55	7226	72.6	42.9	71.1	30.2	82.5
B20a	3.60	7268	72.3	42.7	71.6	30.7	82.9
B20a	3.71	7019	70.0	42.1	70.6	30.7	82.9
B20a	4.17	6225	62.2	40.2	67.9	30.8	83.1
B20a	3.71	7019	70.0	42.1	70.6	30.7	82.9
B20	2.79	4794	66.7	39.4	51.9	23.9	73.7
B20a	2.91	6532	76.3	42.5	65.4	28.2	76.6
B20	3.09	4253	59.7	37.1	50.3	24.5	73.5
CB20	2.36	5739	79.4	39.3	54.6	25.7	72.8
B20	2.57	5117	71.8	39.3	54.6	25.7	72.8
B20	2.41	4663	70.7	39.1	51.0	23.9	70.2
B20	2.63	5117	71.0	39.0	55.1	26.1	72.4
B20	2.41	4663	70.7	39.1	51.0	23.9	70.2
B20	2.73	4123	62.5	36.8	49.4	24.5	70.0
B20	2.35	4838	73.1	38.8	52.5	24.9	69.5
CB201N	1.82	5121	85.3	39.1	49.0	23.2	66.5
B20	2.55	4039	64.1	36.6	48.8	24.5	67.8
B20	2.01	4513	76.3	39.1	49.0	23.2	66.5
B20	2.10	4523	74.6	38.7	50.0	23.9	66.5

Table 2.3.2 Torsion Properties -- Steel Sections 1887-1952

Designation	Torsional Constant	Warping Constant	$(EC_w/GJ)^{1/2}$	Normalized Warping Constant	Warping Statical Moment	Statical Moment	Statical Moment
	J	C _w	a	W _{no}	S _w	Q _f	Q _w
	in.4	in.6	in.	in.2	in.4	in.3	in.3
B20	2.07	4552	75.5	38.7	49.9	23.8	66.3
B20	2.10	4523	74.6	38.7	50.0	23.9	66.5
B20	2.45	4002	65.0	36.4	48.5	24.5	66.5
B20	1.68	4049	79.1	38.6	45.1	21.5	61.5
CB201N	1.40	4561	92.0	38.9	43.9	20.9	60.4
B20	1.55	3947	81.2	38.9	43.9	20.9	60.4
18WF, CB183	11.7	21754	69.4	52.2	166	52.9	134
18WF, B18b	12.2	21754	67.8	52.2	166	52.9	134
18WF, B18b	9.71	19545	72.2	51.7	152	48.7	123
18WF, CB183	9.21	19545	74.1	51.7	152	48.7	123
18WF, CB183	7.22	17502	79.2	51.3	138	44.6	112
18WF, B18b	7.66	17502	76.9	51.3	138	44.6	112
CB183	6.30	19123	88.7	52.4	137	43.4	108
G18	7.55	15020	71.8	49.7	129	42.7	107
CB183N	6.35	18309	86.4	51.3	134	43.5	107
G18	7.22	15922	75.6	51.2	134	43.4	107
18WF, B18b	5.93	15525	82.3	50.9	124	40.5	102
18WF, CB183	5.54	15525	85.2	50.9	124	40.5	102
CB183	5.11	17539	94.2	52.1	126	40.3	99.6
G18	6.18	13627	75.5	49.3	119	39.7	98.8
G18	5.88	14382	79.6	50.9	123	40.1	99.1
G18	6.25	13445	74.7	49.3	119	39.6	98.7
G18	6.74	12685	69.8	49.3	120	40.0	98.9
CB183N	5.07	16666	92.3	51.0	123	40.0	98.9
G18	5.10	12348	79.2	49.1	110	36.7	91.8
G18	4.82	12997	83.5	50.6	113	37.0	91.9
CB183	4.08	15981	101	51.8	116	37.2	91.7
CB183N	4.11	15255	98.1	50.7	113	36.9	91.7
18WF, CB182	5.57	7531	59.2	38.5	77.4	33.0	88.0
18WF, B18a	5.66	7531	58.7	38.5	77.4	33.0	88.0
G18	4.09	11006	83.5	48.8	99.9	33.5	84.4
CB183N	3.28	13877	105	50.4	103	33.9	84.6
G18	3.91	11644	87.8	50.4	103	34.0	84.7
CB182	4.68	6861	61.6	37.2	69.0	30.4	80.5
B18a	4.57	6381	60.1	38.1	69.5	29.9	79.6
18WF, CB182	4.22	6652	63.9	38.1	69.5	29.9	79.4
18WF, B18a	4.30	6652	63.3	38.1	69.5	29.9	79.4
CB182	4.16	7019	66.1	38.1	68.9	29.7	79.1
B18a	4.22	6204	61.7	37.9	68.1	29.5	77.0
B18a	4.22	6204	61.7	37.9	68.1	29.5	77.0
CB182	3.72	6210	65.7	36.9	63.0	28.0	73.9
CB182N	3.15	6228	71.5	37.7	61.8	26.8	71.4
B18a	3.44	5564	64.7	37.7	62.0	26.9	71.6

Table 2.3.2 Torsion Properties -- Steel Sections 1887-1952

Designation	Torsional Constant	Warping Constant	$(EC_w/GJ)^{1/2}$	Normalized Warping Constant	Warping Statical Moment	Statical Moment	Statical Moment
	J	C _w	a	W _{no}	S _w	Q _f	Q _w
	in.4	in.6	in.	in.2	in.4	in.3	in.3
18WF, B18a	3.25	5839	68.2	37.7	62.0	26.9	71.6
18WF, CB182	3.17	5839	69.0	37.7	62.0	26.9	71.6
B18a	3.44	5618	65.0	37.7	62.6	27.2	71.5
B18a	3.44	5618	65.0	37.7	62.6	27.2	71.5
CB182	3.03	5687	69.7	36.7	58.0	26.0	68.5
B18a	2.77	5048	68.7	37.5	57.2	25.0	66.0
B18a	2.77	5048	68.7	37.5	57.2	25.0	66.0
CB182N	2.43	5576	77.1	37.4	55.7	24.4	64.9
B18a	2.67	4924	69.1	37.4	56.0	24.5	65.1
18WF, B18a	2.52	5190	73.1	37.4	56.0	24.5	65.1
18WF, CB182	2.45	5190	74.1	37.4	56.0	24.5	65.1
18WF, CB181	2.19	3629	65.5	33.2	43.6	21.8	60.9
18WF, B18	2.27	3629	64.3	33.2	43.6	21.8	60.9
B18a	2.16	4446	73.0	37.3	51.4	22.6	60.1
B18	2.07	2962	60.9	33.4	37.9	18.5	57.0
B18	2.23	2711	56.1	32.5	37.5	18.8	57.0
CB181	2.03	3784	69.5	33.3	42.6	21.3	59.0
B18	2.17	3396	63.7	33.2	42.7	21.4	58.7
CB181N	1.97	3761	70.2	33.2	42.4	21.3	58.3
18WF, B18	1.75	3212	68.9	32.9	39.1	19.7	55.4
18WF, CB181	1.68	3212	70.4	32.9	39.1	19.7	55.4
B18	1.89	3138	65.6	32.9	40.0	20.2	55.6
B18	1.89	3138	65.6	32.9	40.0	20.2	55.6
B18	1.71	2856	65.7	33.0	37.1	18.5	53.6
B18	1.71	2856	65.7	33.0	37.1	18.5	53.6
B18	1.82	2598	60.9	32.0	36.5	18.8	52.8
B18	1.65	2945	67.9	32.8	37.9	19.2	52.9
CB181N	1.48	3318	76.1	33.0	37.7	19.1	52.7
CB181N	1.49	3334	76.1	33.0	37.9	19.2	52.8
B18	1.64	2972	68.4	33.0	38.2	19.3	53.0
B18	1.59	2811	67.6	32.9	36.7	18.5	52.2
B18	1.65	2945	67.9	32.8	37.9	19.2	52.9
CB181	1.31	3087	78.2	33.0	35.0	17.6	50.5
18WF, CB181	1.26	2825	76.1	32.7	34.9	17.7	50.0
18WF, B18	1.33	2825	74.3	32.7	34.9	17.7	50.0
B18	1.42	2771	71.1	32.8	36.0	18.4	50.2
B18	1.41	2737	70.8	32.7	35.8	18.2	49.9
CB181N	1.27	3132	79.9	32.8	35.7	18.2	49.7
B18	1.41	2737	70.8	32.7	35.8	18.2	49.9
B18	1.44	2743	70.1	32.6	36.2	18.5	49.9
B18	1.44	2743	70.1	32.6	36.2	18.5	49.9
B18	1.63	2523	63.3	31.7	35.8	18.8	50.1
B64	1.14	2296	72.3	32.8	30.9	15.6	46.7
B64	1.14	2296	72.3	32.8	30.9	15.6	46.7

Table 2.3.2 Torsion Properties -- Steel Sections 1887-1952

Designation	Torsional Constant	Warping Constant	(EC_w/GJ) ^{1/2} =	Normalized Warping Constant	Warping Statical Moment	Statical Moment	Statical Moment
	J	C _w	a	W _{no}	S _w	Q _f	Q _w
	in.4	in.6	in.	in.2	in.4	in.3	in.3
B18	1.24	2569	73.1	32.6	33.8	17.3	47.6
B18	1.24	2594	73.7	32.7	34.0	17.4	47.7
CB181N	1.11	2946	82.9	32.7	33.7	17.2	47.4
CB181	1.11	2946	82.9	32.7	33.7	17.2	47.4
18WF, CB181	1.02	2530	80.2	32.6	31.7	16.1	46.3
18WF, B18	1.08	2530	78.0	32.6	31.7	16.1	46.3
B34	1.70	1495	47.8	26.0	25.9	16.3	45.7
B23	1.21	1301	52.7	26.2	21.8	13.6	42.6
----	0.90	2404	83.2	32.5	30.3	15.5	44.3
CB165	8.45	25001	87.5	53.9	174	47.6	113
16WF, CB163	10.2	15500	62.6	45.4	137	44.4	111
16WF, B16b	10.7	15500	61.1	45.4	137	44.4	111
CB165	6.86	22917	93.0	53.5	161	44.1	104
16WF, CB163	8.07	13901	66.8	45.0	124	40.8	101
16WF, B16b	8.53	13901	65.0	45.0	124	40.8	101
CB165	5.64	21140	98.5	53.2	149	41.1	97.1
16WF, CB163	6.22	12357	71.7	44.5	112	37.2	92.1
16WF, B16b	6.63	12357	69.5	44.5	112	37.2	92.1
G16	7.01	11798	66.0	44.4	114	37.7	91.3
G16	5.96	11010	69.2	44.7	107	35.3	86.7
CB164N	4.86	13925	86.1	46.6	112	35.6	87.0
CB164	4.81	13738	86.0	46.7	110	35.0	86.4
16WF, CB163	4.77	10931	77.0	44.2	101	33.6	83.6
16WF, B16b	5.14	10931	74.2	44.2	101	33.6	83.6
G16	5.66	10610	69.7	44.1	104	34.8	84.1
CB164N	3.82	12583	92.4	46.3	102	32.6	79.7
CB164	3.81	12470	92.1	46.3	101	32.2	79.3
G16	4.73	9815	73.3	44.3	97.2	32.4	79.3
G16	4.59	9557	73.4	43.8	95.7	32.1	77.6
16WF, B16a	4.96	5218	52.2	33.2	62.3	27.2	72.1
16WF, CB162	4.87	5218	52.6	33.2	62.3	27.2	72.1
CB164	2.96	11238	99.2	46.0	91.5	29.4	72.3
G16	3.75	8737	77.6	44.0	88.5	29.7	72.5
CB164N	2.96	11345	99.7	46.0	92.4	29.8	72.6
G16	3.67	8532	77.6	43.5	87.4	29.4	71.2
B16a	4.30	4695	53.2	33.0	58.8	26.0	67.1
16WF, B16a	3.78	4598	56.1	32.8	55.7	24.6	65.1
16WF, CB162	3.70	4598	56.7	32.8	55.7	24.6	65.1
CB163	3.37	4852	61.0	33.1	54.9	24.4	63.1
B16a	3.66	4401	55.8	33.1	55.5	24.6	63.6
CB163N	3.39	4819	60.7	32.9	54.9	24.5	63.3
B16a	3.41	4195	56.5	32.7	53.6	23.9	61.4
16WF, B16a	2.81	3995	60.7	32.5	49.4	22.0	58.2

Table 2.3.2 Torsion Properties -- Steel Sections 1887-1952

Designation	Torsional Constant	Warping Constant	$(EC_w/GJ)^{1/2}$	Normalized Warping Constant	Warping Statical Moment	Statical Moment	Statical Moment
	J	C _w	a	W _{no}	S _w	Q _f	Q _w
	in.4	in.6	in.	in.2	in.4	in.3	in.3
16WF, CB162	2.74	3995	61.5	32.5	49.4	22.0	58.2
B16a	2.92	3931	59.1	32.8	50.4	22.5	58.5
CB163N	2.73	4394	64.5	32.6	50.5	22.7	58.4
CB163	2.71	4420	65.0	32.8	50.4	22.5	58.2
B16a	2.71	3759	59.9	32.5	48.9	21.9	56.4
CB163	2.14	3999	69.5	32.6	45.9	20.7	53.3
CB163N	2.14	3960	69.2	32.4	45.8	20.7	53.5
B16a	2.30	3494	62.8	32.6	45.7	20.5	53.4
16WF, B16a	2.11	3501	65.5	32.2	43.9	19.8	52.3
16WF, CB162	2.05	3501	66.5	32.2	43.9	19.8	52.3
B16a	2.16	3353	63.4	32.3	44.4	20.0	51.8
B16	1.69	2233	58.5	28.6	32.9	17.1	46.2
B16	1.71	2194	57.6	28.2	32.7	17.0	45.8
CB162N	1.50	2508	65.7	28.6	32.8	17.1	46.0
CB162	1.60	2326	61.4	27.6	31.6	16.9	45.8
16WF, CB161	1.53	2123	60.0	27.6	30.7	16.4	45.4
16WF, B16	1.59	2123	58.8	27.6	30.7	16.4	45.4
16WF	1.17	1433	56.3	27.4	23.7	12.5	38.2
B16	1.24	1930	63.4	28.3	29.1	15.2	41.2
16WF, B16	1.17	1845	63.9	27.4	27.1	14.7	40.5
16WF, CB161	1.12	1845	65.4	27.4	27.1	14.7	40.5
CB162N	1.10	2196	71.9	28.3	29.1	15.2	41.1
CB162	1.18	2054	67.1	27.3	28.1	15.2	41.1
B16	1.28	1915	62.4	28.0	29.1	15.4	41.0
CB162	0.89	1724	70.6	27.4	23.6	12.6	37.1
B16	0.90	1657	68.9	28.1	25.6	13.6	36.5
CB162N	0.79	1921	79.5	28.1	25.6	13.6	36.5
B16	0.93	1647	67.6	27.7	25.7	13.7	36.4
16WF, B16	0.85	1591	69.8	27.1	23.9	13.0	35.9
16WF, CB161	0.80	1591	71.8	27.1	23.9	13.0	35.9
CB162	0.84	1785	74.1	27.1	24.7	13.5	36.3
16WF	0.93	1356	61.3	26.9	22.9	12.5	34.5
CB161	0.81	1151	60.7	23.3	18.5	11.6	33.3
CB162N	0.59	1674	85.9	28.0	22.5	11.9	32.9
B16	0.68	1412	73.2	28.0	22.4	11.9	32.9
16WF, B16	0.59	1314	75.6	27.0	20.2	11.0	31.5
16WF, CB161	0.55	1314	78.4	27.0	20.2	11.0	31.5
B16	0.57	1269	75.9	27.9	20.6	10.9	30.8
CB161	0.64	1044	65.0	23.2	16.9	10.7	30.6
---	0.47	686	61.3	21.3	13.0	8.9	26.5
---	0.27	510	70.3	21.0	10.0	6.9	21.5
G15b	26.8	16406	39.8	40.5	164	51.8	127
G15b	26.8	16396	39.8	40.5	164	51.8	127

Table 2.3.2 Torsion Properties -- Steel Sections 1887-1952

Designation	Torsional Constant	Warping Constant	(EC_w/GJ) ^{1/2} =	Normalized Warping Constant	Warping Statical Moment	Statical Moment	Statical Moment
	J	C _w	a	W _{no}	S _w	Q _f	Q _w
	in.4	in.6	in.	in.2	in.4	in.3	in.3
G15b	23.7	15374	41.0	40.2	156	49.4	121
G15b	23.7	15364	41.0	40.2	156	49.4	121
G15b	25.8	14897	38.7	40.1	158	50.0	123
G15b	24.9	15449	40.1	40.1	158	50.0	122
G15b	20.8	14367	42.3	39.9	147	46.9	115
G15b	20.8	14358	42.3	39.9	147	46.9	115
G15b	17.9	13284	43.9	39.6	138	44.3	108
G15a	12.1	11420	49.4	39.7	119	39.9	98.1
G15a	12.1	11415	49.4	39.7	119	39.9	98.1
CB153N	10.0	12240	56.3	39.6	116	39.4	97.0
G15	11.1	11039	50.7	39.6	116	39.4	96.9
G15a	10.2	10495	51.6	39.4	111	37.5	91.9
G15a	10.2	10490	51.6	39.4	111	37.5	91.9
G15a	11.1	9943	48.1	39.3	112	37.7	92.3
G15a	10.5	10423	50.7	39.3	112	37.6	92.1
G15	8.78	9844	53.9	39.2	105	36.2	88.6
CB153N	7.85	11006	60.3	39.1	105	36.2	88.5
G15a	8.62	9634	53.8	39.1	104	35.1	86.0
G15a	8.62	9629	53.8	39.1	104	35.1	86.0
G15a	7.59	9043	55.5	38.9	98.6	33.6	81.9
G15	6.91	8739	57.2	38.8	95.5	33.1	80.8
CB153N	6.12	9883	64.7	38.8	95.5	33.1	80.8
G15	5.69	7940	60.1	38.5	88.2	30.7	75.0
CB153N	5.00	9069	68.5	38.5	88.2	30.7	75.0
G15	4.81	7351	62.9	38.7	81.9	29.0	71.7
G15	4.81	7346	62.9	38.7	81.9	29.0	71.7
G15	3.83	6567	66.6	38.4	74.7	26.7	65.7
G15	3.83	6567	66.6	38.4	74.7	26.7	65.7
G15	4.40	5915	59.0	37.4	74.1	27.1	66.0
G15	4.03	6257	63.4	37.4	73.4	26.8	65.7
B15b	6.35	2701	33.2	25.0	44.6	23.1	61.3
B15a	5.16	3215	40.2	27.3	47.6	23.4	62.1
CB152N	4.81	3468	43.2	27.3	47.5	23.4	62.0
B15b	5.51	3029	37.7	26.4	46.6	23.1	60.8
B15b	5.33	3014	38.3	26.4	46.0	22.8	60.3
B15b	5.33	3009	38.2	26.4	46.0	22.8	60.3
B15b	5.51	3029	37.7	26.4	46.6	23.1	60.8
G15	3.07	5850	70.2	38.1	68.0	24.4	60.4
G15	3.07	5850	70.2	38.1	68.0	24.4	60.4
CB152N	3.74	3099	46.3	27.0	43.0	21.3	56.5
B15a	4.02	2848	42.8	27.0	43.0	21.3	56.5
G15	2.67	5463	72.8	37.9	64.5	23.2	57.1
B15a	3.66	2072	38.3	25.7	34.5	17.6	52.0
B15a	3.49	2131	39.8	25.7	34.1	17.4	51.7

Table 2.3.2 Torsion Properties -- Steel Sections 1887-1952

Designation	Torsional Constant	Warping Constant	$(EC_w/GJ)^{1/2}$	Normalized Warping Constant	Warping Statical Moment	Statical Moment	Statical Moment
	J	C _w	a	W _{no}	S _w	Q _f	Q _w
	in.4	in.6	in.	in.2	in.4	in.3	in.3
CB152N	2.82	2731	50.1	26.7	38.3	19.2	50.9
B15a	3.04	2487	46.1	26.7	38.3	19.2	50.8
B15a	3.19	2195	42.2	25.2	35.4	18.8	50.5
B15a	3.19	2195	42.2	25.2	35.4	18.8	50.5
CB152N	2.21	2456	53.6	26.4	34.8	17.6	46.5
B15a	2.40	2220	48.9	26.5	34.8	17.6	46.5
B15a	2.53	1963	44.8	25.0	32.2	17.3	46.2
B15a	2.56	1947	44.4	25.0	32.3	17.4	46.2
B15a	2.53	1963	44.8	25.0	32.2	17.3	46.2
B15a	2.56	1947	44.4	25.0	32.3	17.4	46.2
B15a	2.69	1889	42.6	24.9	32.6	17.6	46.4
B15a	2.01	1750	47.5	24.8	29.3	15.9	42.4
B15a	2.01	1750	47.5	24.8	29.3	15.9	42.4
B15	1.78	1683	49.5	24.9	27.9	15.4	42.0
CB152N	1.63	1859	54.3	24.9	27.9	15.4	41.9
B15a	1.55	1539	50.7	24.6	26.2	14.3	38.5
B15	1.40	1317	49.3	24.6	22.8	12.5	37.4
B15	1.41	1263	48.1	24.6	23.0	12.7	37.4
B15	1.31	1457	53.6	24.7	24.7	13.8	37.5
CB151N	1.20	1631	59.4	24.7	24.7	13.8	37.4
B15	1.22	1416	54.8	24.6	24.2	13.6	36.4
B15	1.22	1416	54.8	24.6	24.2	13.6	36.4
B15	1.21	1222	51.0	24.3	22.5	12.7	35.5
B15	1.12	1254	53.7	24.3	22.1	12.5	34.6
B15	1.04	1316	57.2	24.5	22.8	12.9	34.3
B15	1.04	1316	57.2	24.5	22.8	12.9	34.3
CB151N	0.86	1424	65.4	24.4	21.8	12.4	33.2
B15	0.95	1251	58.4	24.4	21.8	12.4	33.2
B15	0.95	1261	58.6	24.4	22.0	12.5	33.1
B15	0.98	1223	56.7	24.1	21.8	12.5	33.2
B15	0.95	1261	58.6	24.4	22.0	12.5	33.1
B15	0.98	1223	56.7	24.1	21.8	12.5	33.2
B15	1.05	1175	53.8	24.1	22.0	12.7	33.2
B65	0.72	1052	61.3	24.5	18.9	10.6	30.6
B65	0.72	1052	61.3	24.5	18.9	10.6	30.6
B35	1.09	701	40.9	19.8	16.0	11.0	30.2
B15	0.76	1128	61.8	24.3	20.0	11.4	30.6
B15	0.70	1069	63.0	24.2	19.2	10.9	29.6
CB151N	0.62	1241	72.0	24.2	19.1	10.9	29.5
B24	0.74	611	46.3	20.0	13.4	9.2	27.7
14WF, CB145	13.5	26587	71.5	50.4	198	51.2	120
14WF, B14d	13.5	26587	71.5	50.4	198	51.2	120
CB145N	13.6	26587	71.2	50.4	198	51.2	120

Table 2.3.2 Torsion Properties -- Steel Sections 1887-1952

Designation	Torsional Constant	Warping Constant	(EC_w/GJ) ^{1/2} =	Normalized Warping Constant	Warping Statical Moment	Statical Moment	Statical Moment
	J	C _w	a	W _{no}	S _w	Q _f	Q _w
	in.4	in.6	in.	in.2	in.4	in.3	in.3
CB146	12.8	27397	74.5	51.1	201	50.5	118
CB145N	11.2	24475	75.3	50.0	183	47.8	112
14WF, CB145	11.1	24475	75.6	50.0	183	47.9	112
14WF, B14d	11.1	24475	75.6	50.0	183	47.9	112
CB146	10.2	24913	79.4	50.7	184	46.6	108
14WF, CB145	9.20	22614	79.8	49.7	171	44.8	105
14WF, B14d	9.20	22614	79.8	49.7	171	44.8	105
CB145N	9.28	22609	79.4	49.7	171	44.8	105
CB146	8.04	22498	85.1	50.3	168	42.7	99.2
14WF, B14d	7.48	20717	84.7	49.3	157	41.5	96.9
14WF, CB145	7.48	20717	84.7	49.3	157	41.5	96.9
CB145N	7.55	20708	84.3	49.3	157	41.5	96.9
CB146	6.34	20381	91.2	49.9	153	39.2	90.9
CB145	8.84	13096	61.9	40.5	121	38.3	90.4
CB145N	6.10	18949	89.7	49.0	145	38.4	89.5
14WF, CB145	6.02	18945	90.3	49.0	145	38.5	89.5
14WF, B14d	6.02	18945	90.3	49.0	145	38.5	89.5
CB146	4.75	18092	99.3	49.4	137	35.3	81.8
14WF, CB145	4.74	17152	96.8	48.6	132	35.2	82.0
14WF, B14d	4.74	17152	96.8	48.6	132	35.2	82.0
CB145	6.62	11565	67.2	40.0	108	34.5	81.2
CB145N	4.80	17152	96.2	48.6	132	35.2	82.0
CB145N	3.74	15493	104	48.3	120	32.2	74.8
14WF, B14d	3.68	15493	104	48.3	120	32.2	74.8
14WF, CB145	3.68	15493	104	48.3	120	32.2	74.8
CB146	3.46	15890	109	49.0	122	31.5	72.8
CB145	4.80	10098	73.8	39.6	95.6	30.7	72.1
14WF, CB144	4.41	10126	77.1	40.3	94.2	30.2	71.7
14WF, B14c	4.41	10126	77.1	40.3	94.2	30.2	71.7
CB144N	4.47	10121	76.6	40.3	94.2	30.2	71.7
CB144N	3.58	9208	81.6	40.0	86.2	27.7	66.0
14WF, CB144	3.52	9208	82.3	40.0	86.2	27.7	66.0
14WF, B14c	3.52	9208	82.3	40.0	86.2	27.7	66.0
CB144	3.92	6216	64.1	34.3	67.9	25.7	63.5
14WF, CB143	3.86	5999	63.5	33.8	66.6	25.3	61.8
14WF, B14b	3.86	5999	63.5	33.8	66.6	25.3	61.8
CB143N	3.92	5995	63.0	33.8	66.5	25.2	61.8
CB143N	3.06	5394	67.5	33.5	60.4	23.0	56.5
14WF, CB143	3.01	5394	68.1	33.5	60.4	23.0	56.4
14WF, B14b	3.01	5394	68.1	33.5	60.4	23.0	56.4
CB144	2.95	5514	69.6	34.0	60.9	23.2	57.2
CB144	2.16	4845	76.2	33.6	54.0	20.8	51.0
CB143N	2.24	4722	73.9	33.2	53.3	20.5	50.2

Table 2.3.2 Torsion Properties -- Steel Sections 1887-1952

Designation	Torsional Constant	Warping Constant	$(EC_w/GJ)^{1/2}$	Normalized Warping Constant	Warping Statical Moment	Statical Moment	Statical Moment
	J	C _w	a	W _{no}	S _w	Q _f	Q _w
	in.4	in.6	in.	in.2	in.4	in.3	in.3
14WF, CB143	2.19	4722	74.7	33.2	53.3	20.5	50.2
14WF, B14b	2.19	4722	74.7	33.2	53.3	20.5	50.2
CB143N	2.45	2872	55.1	27.3	39.4	18.5	47.5
14WF, CB142	2.49	2835	54.2	27.0	39.3	18.4	46.9
14WF, B14a	2.49	2835	54.2	27.0	39.3	18.4	46.9
CB142N	2.54	2830	53.7	27.0	39.2	18.4	46.9
CB143	1.90	2575	59.3	27.0	35.6	16.9	43.2
14WF, CB142	1.93	2536	58.3	26.8	35.5	16.8	42.6
14WF, B14a	1.93	2536	58.3	26.8	35.5	16.8	42.6
CB142N	1.97	2536	57.7	26.8	35.5	16.8	42.6
CB143	1.43	2282	64.3	26.8	31.9	15.3	38.9
14WF, CB142	1.44	2240	63.4	26.5	31.6	15.1	38.2
14WF, CB142	1.44	2240	63.4	26.5	31.6	15.1	38.2
CB142N	1.48	2236	62.5	26.5	31.6	15.1	38.2
14WF, CB142	1.05	1950	69.5	26.3	27.8	13.4	33.9
14WF, B14a	1.05	1950	69.5	26.3	27.8	13.4	33.9
CB142N	1.08	1950	68.4	26.3	27.8	13.4	34.0
B14	1.24	1276	51.7	23.3	23.0	12.8	34.3
B14	1.24	1237	50.8	23.0	22.6	12.7	33.8
B14	1.23	1271	51.8	23.3	23.0	12.8	34.1
CB141N	1.10	1430	58.1	23.3	23.0	12.8	34.1
CB142	1.07	1411	58.4	23.3	22.6	12.6	33.9
14WF, CB141	1.09	1312	55.8	23.2	22.6	12.7	33.9
14WF, B14	1.14	1312	54.5	23.2	22.6	12.7	33.9
CB142	0.87	1287	62.0	23.2	20.8	11.7	31.3
14WF	0.86	866	51.0	23.0	17.3	9.6	28.5
CB142	0.71	1111	63.7	23.2	17.9	9.9	28.9
14WF, CB141	0.81	1139	60.5	23.1	20.0	11.3	30.4
14WF, B14	0.85	1139	58.9	23.1	20.0	11.3	30.4
B14	0.89	1083	56.2	23.1	20.1	11.3	30.2
B14	0.90	1063	55.3	22.7	20.0	11.3	30.0
B14	0.87	1079	56.6	23.1	20.1	11.3	30.0
CB141N	0.76	1231	64.6	23.1	20.0	11.3	29.9
CB142	0.69	1173	66.5	23.0	19.1	10.8	28.8
14WF, CB141	0.58	977	66.3	22.9	17.5	9.92	26.9
14WF, B14	0.61	977	64.2	22.9	17.5	9.92	26.9
B14	0.64	900	60.4	22.5	17.4	10.0	26.3
CB142	0.53	1056	71.5	22.9	17.3	9.86	26.3
B14	0.62	913	61.7	22.9	17.5	9.95	26.4
CB141N	0.54	1064	71.4	22.9	17.5	9.95	26.4
14WF	0.63	817	58.0	22.6	16.7	9.55	25.6
B14	0.46	764	65.6	22.8	15.1	8.59	23.6
CB141	0.45	710	64.1	20.3	13.1	8.36	23.3
CB141N	0.39	914	78.2	22.7	15.1	8.59	23.4

Table 2.3.2 Torsion Properties -- Steel Sections 1887-1952

Designation	Torsional Constant	Warping Constant	$(EC_w/GJ)^{1/2}$	Normalized Warping Constant	Warping Statical Moment	Statical Moment	Statical Moment
	J	C _w	a	W _{no}	S _w	Q _f	Q _w
	in.4	in.6	in.	in.2	in.4	in.3	in.3
14WF, CB141	0.38	795	73.3	22.7	14.6	8.34	23.2
14WF, B14	0.42	795	70.2	22.7	14.6	8.34	23.2
----	0.36	375	51.8	16.9	8.9	6.72	19.6
----	0.21	287	59.0	16.7	7.0	5.35	16.1
----	0.13	125	49.0	13.7	3.7	3.54	12.2
CB125N	4.82	8065	65.8	35.4	85.3	27.0	63.8
12WF, CB124	4.80	8065	65.9	35.4	85.3	27.0	63.7
12WF, B12c	4.80	8065	65.9	35.4	85.3	27.0	63.7
CB124	5.55	4585	46.3	28.5	60.2	22.0	56.7
CB124C	4.62	7228	63.7	33.6	80.6	25.9	59.9
CB125N	3.87	7335	70.0	35.2	78.2	24.9	58.8
12WF, CB124	3.85	7335	70.2	35.2	78.2	24.9	58.8
12WF, B14C	3.85	7335	70.2	35.2	78.2	24.9	58.8
G12a	5.14	4214	46.1	29.1	61.6	22.7	54.9
G12a	5.14	4214	46.1	29.1	61.6	22.7	54.9
CB124B	3.25	6083	69.6	34.9	65.2	20.1	52.2
CB124	4.51	4320	49.8	27.9	57.9	22.0	53.1
12WF, CB124	2.94	6546	75.9	34.9	70.4	22.6	53.2
12WF, B12c	2.94	6546	75.9	34.9	70.4	22.6	53.2
CB125N	2.96	6546	75.7	34.9	70.4	22.5	53.3
G12a	4.89	3778	44.7	34.4	80.5	25.3	59.0
G12a	4.14	3778	48.6	28.8	56.3	21.0	50.4
G12a	4.76	3435	43.2	28.0	55.9	21.4	50.7
CB124B	2.56	5863	76.9	34.5	63.6	20.1	49.6
G12a	4.39	3604	46.1	28.0	55.3	21.1	50.5
CB123B	3.55	3257	48.7	26.0	46.9	19.7	47.7
G12a	3.35	3382	51.2	28.6	51.4	19.2	46.4
G12a	3.35	3382	51.2	28.6	51.4	19.2	46.4
12WF, CB124	2.19	5787	82.7	34.5	62.8	20.3	47.7
12WF, B12c	2.19	5787	82.7	34.5	62.8	20.3	47.7
CB124B	2.19	5684	82.0	34.2	62.3	20.1	47.4
CB125N	2.20	5787	82.5	34.5	62.8	20.2	47.7
12WF, CB123	2.76	4009	61.3	29.2	51.5	19.6	47.0
12WF, B12b	2.76	4009	61.3	29.2	51.5	19.6	47.0
CB124N	2.77	4009	61.2	29.2	51.5	19.6	47.0
G12	2.71	3146	54.9	28.7	47.9	18.3	44.2
G12	2.71	3142	54.8	28.7	47.9	18.3	44.2
CB123B	2.70	2889	52.6	25.7	42.1	17.8	43.1
G12	2.62	3115	55.5	28.7	47.6	18.3	43.7
12WF, B12b	2.11	3581	66.4	28.9	46.4	17.9	42.4
12WF, CB123	2.11	3581	66.4	28.9	46.4	17.9	42.4
CB124N	2.11	3581	66.2	28.9	46.4	17.9	42.5
G12	2.10	2756	58.3	28.5	43.1	16.6	40.0

Table 2.3.2 Torsion Properties -- Steel Sections 1887-1952

Designation	Torsional Constant	Warping Constant	$(EC_w/GJ)^{1/2}$	Normalized Warping Constant	Warping Statical Moment	Statical Moment	Statical Moment
	J	C _w	a	W _{no}	S _w	Q _f	Q _w
	in.4	in.6	in.	in.2	in.4	in.3	in.3
G12	2.10	2756	58.3	28.5	43.1	16.6	40.0
G12	2.05	2738	58.8	28.5	42.9	16.5	39.7
G12	2.22	2623	55.3	27.7	42.3	16.7	40.1
CB123B	2.11	2599	56.5	25.5	38.2	16.3	39.3
G12	2.45	2458	50.9	27.7	42.8	16.9	40.2
12WF, B12b	1.59	3168	71.9	28.7	41.3	16.0	38.2
12WF, CB123	1.59	3168	71.9	28.7	41.3	16.0	38.2
CB124N	1.59	3168	71.7	28.7	41.3	16.0	38.3
G12	1.71	2476	61.2	28.3	39.6	15.3	37.0
G12	1.71	2476	61.2	28.3	39.6	15.3	37.0
12WF, B12a	1.79	1881	52.2	23.3	30.2	14.3	35.4
12WF, CB122	1.79	1881	52.2	23.3	30.2	14.3	35.4
CB123	1.80	1935	52.8	23.4	30.9	14.6	36.1
CB123N	1.80	1881	52.0	23.3	30.2	14.3	35.5
B12a	2.22	1165	36.9	19.6	24.3	13.4	34.3
12WF, B12a	1.32	1649	56.8	23.1	26.7	12.7	31.6
12WF, CB122	1.32	1649	56.8	23.1	26.7	12.7	31.6
CB123	1.33	1704	57.6	23.2	27.5	13.1	32.3
CB123N	1.33	1649	56.7	23.1	26.7	12.7	31.7
B12a	1.83	945	36.6	18.6	20.8	12.1	31.3
B12a	1.69	1021	39.5	19.4	21.8	12.2	30.9
B12a	1.38	822	39.3	18.4	18.5	10.9	28.1
B12a	1.28	896	42.7	19.2	19.5	11.0	27.9
12WF, B12a	0.96	1439	62.4	22.8	23.6	11.4	28.0
12WF, CB122	0.96	1439	62.4	22.8	23.6	11.4	28.0
CB123	0.95	1478	63.5	22.9	24.1	11.6	28.5
CB123N	0.96	1439	62.2	22.8	23.6	11.4	28.0
B12a	1.04	716	42.3	18.2	16.5	9.83	25.2
B12a	1.14	665	38.9	18.0	16.3	9.87	25.3
B12a	1.07	695	41.0	18.0	16.3	9.84	25.3
CB122	0.83	869	52.2	19.2	17.0	9.85	25.5
12WF, B12	0.88	811	49.0	19.2	17.0	9.89	25.5
12WF, CB121	0.84	811	50.1	19.2	17.0	9.89	25.5
CB122N	0.84	880	52.0	19.2	17.2	10.0	25.6
B12	0.94	778	46.2	19.2	17.1	10.0	25.6
CB122	0.60	705	55.2	19.2	13.7	7.82	22.4
12WF	0.70	593	46.8	19.0	14.2	8.24	22.1
B12	0.67	533	45.3	17.9	12.8	7.82	21.7
CB122N	0.59	755	57.6	19.0	14.9	8.74	22.5
B12	0.67	657	50.4	19.0	14.9	8.74	22.5
12WF, B12	0.63	698	53.7	19.0	14.9	8.74	22.5
12WF, CB121	0.59	698	55.2	19.0	14.9	8.74	22.5
CB122	0.59	755	57.8	19.0	14.9	8.73	22.5

Table 2.3.2 Torsion Properties -- Steel Sections 1887-1952

Designation	Torsional Constant	Warping Constant	$(EC_w/GJ)_{1/2}$	Normalized Warping Constant	Warping Statical Moment	Statical Moment	Statical Moment
	J	C _w	a	W _{no}	S _w	Q _f	Q _w
	in.4	in.6	in.	in.2	in.4	in.3	in.3
B12	0.66	657	50.6	19.0	14.9	8.74	22.4
B12	0.67	489	43.4	17.8	12.7	7.80	21.2
12WF, B12	0.57	669	55.0	19.0	14.4	8.46	21.8
12WF, CB121	0.54	669	56.6	19.0	14.4	8.46	21.8
B12	0.64	580	48.5	18.2	13.7	8.34	21.6
12WF	0.60	570	49.5	18.8	13.9	8.24	20.8
B12	0.56	509	48.6	17.7	12.5	7.82	20.1
B12	0.60	473	45.3	17.6	12.4	7.80	20.1
B12	0.53	530	50.9	18.0	12.7	7.80	20.1
B12	0.47	550	55.3	18.8	12.8	7.61	19.6
12WF, B12	0.43	587	59.4	18.8	12.8	7.61	19.5
12WF, CB121	0.40	587	61.5	18.8	12.8	7.61	19.5
CB122	0.40	644	64.7	18.8	12.8	7.61	19.5
CB122N	0.40	644	64.7	18.8	12.8	7.61	19.5
B66	0.44	423	50.1	17.4	10.7	6.79	18.7
B66	0.44	423	50.1	17.4	10.7	6.79	18.7
B36	0.66	287	33.7	14.4	9.20	6.98	18.6
12WF, CB121	0.36	555	63.4	18.8	12.2	7.24	18.8
12WF, B12	0.39	555	61.0	18.8	12.2	7.24	18.8
B12	0.33	451	59.5	18.7	10.9	6.49	17.2
12WF, B12	0.30	481	64.6	18.7	10.8	6.40	17.0
12WF, CB121	0.27	481	67.6	18.7	10.8	6.40	17.0
B12	0.32	444	59.9	18.7	10.8	6.39	17.0
B12	0.34	414	56.5	17.9	10.3	6.37	16.9
CB122N	0.27	537	72.1	18.7	10.8	6.38	17.0
B25	0.40	245	39.9	14.5	7.60	5.75	16.4
CB121	0.30	460	63.1	17.3	9.92	6.35	17.0
CB103N	3.32	2999	48.4	24.4	46.1	17.4	41.0
10WF, CB103	3.27	2997	48.7	24.4	46.1	17.4	41.0
10WF, B10b	3.27	2997	48.7	24.4	46.1	17.4	41.0
CB103A	2.96	2369	45.5	24.6	35.9	12.7	35.3
CB103	3.17	1878	39.1	22.1	31.7	12.4	34.5
10WF, CB103	2.49	2666	52.6	24.1	41.5	15.8	37.0
10WF, B10b	2.49	2666	52.6	24.1	41.5	15.8	37.0
CB103N	2.53	2666	52.2	24.1	41.5	15.8	37.0
CB103A	2.20	2267	51.7	24.3	34.9	12.7	33.5
CB103	2.16	1752	45.8	21.6	30.3	12.4	32.0
CB103N	1.88	2347	56.9	23.8	36.9	14.2	33.1
10WF, CB103	1.84	2345	57.4	23.8	36.9	14.2	33.1
10WF, B10b	1.84	2345	57.4	23.8	36.9	14.2	33.1
CB103A	1.68	2169	57.8	24.0	33.9	12.7	31.6
G10	1.94	1496	44.6	21.5	30.4	12.9	30.4
G10	1.94	1496	44.6	21.5	30.4	12.9	30.4
CB103	1.61	1636	51.3	21.1	29.0	12.4	29.4

Table 2.3.2 Torsion Properties -- Steel Sections 1887-1952

Designation	Torsional Constant	Warping Constant	$(EC_w/GJ)^{1/2}$	Normalized Warping Constant	Warping Statical Moment	Statical Moment	Statical Moment
	J	C _w	a	W _{no}	S _w	Q _f	Q _w
	in.4	in.6	in.	in.2	in.4	in.3	in.3
10WF, B10b	1.38	2073	62.4	23.6	32.9	12.7	29.7
10WF, CB103	1.38	2073	62.4	23.6	32.9	12.7	29.7
CB103A	1.37	2073	62.6	23.6	32.9	12.7	29.8
CB103N	1.40	2073	61.8	23.6	32.9	12.7	29.7
G10	1.47	1322	48.3	21.5	27.3	11.7	27.6
10WF, B10a	1.50	1201	45.6	19.1	23.6	11.3	27.0
10WF, CB102	1.50	1201	45.6	19.1	23.6	11.3	27.0
CB102N	1.53	1201	45.1	19.1	23.6	11.3	27.0
G10	1.46	1295	48.0	21.2	27.0	11.6	27.2
G10	1.46	1295	48.0	21.2	27.0	11.6	27.2
G10	1.47	1275	47.3	21.2	27.1	11.6	27.1
G10	1.64	1191	43.4	21.2	27.3	11.7	27.2
CB102	1.20	851	42.8	20.0	15.9	7.04	22.1
G10	1.19	1182	50.7	21.3	25.0	10.7	25.4
G10	1.18	1159	50.4	21.1	24.7	10.6	25.0
G10	1.18	1159	50.4	21.1	24.7	10.6	25.0
CB102N	1.16	1063	48.8	18.9	21.1	10.1	24.3
10WF, CB102	1.13	1063	49.4	18.9	21.1	10.1	24.3
10WF, B10a	1.13	1063	49.4	18.9	21.1	10.1	24.3
10WF, B10a	0.97	994	51.5	18.8	19.8	9.53	23.0
10WF, CB102	0.97	994	51.5	18.8	19.8	9.53	23.0
10WF, CB102	0.83	929	53.9	18.7	18.6	8.96	21.7
10WF, B10a	0.83	929	53.9	18.7	18.6	8.96	21.7
CB102N	0.85	926	53.2	18.7	18.6	8.96	21.6
CB102	0.66	796	55.7	19.6	15.2	7.04	19.9
CB102	0.60	792	58.4	18.6	16.0	7.74	19.0
10WF, CB102	0.58	792	59.5	18.6	16.0	7.74	18.9
10WF, B10a	0.58	792	59.5	18.6	16.0	7.74	18.9
CB102	0.42	752	67.8	19.2	14.7	7.04	18.1
CB101	0.60	438	43.6	14.8	11.1	6.95	17.8
10WF	0.60	252	33.1	14.1	8.12	5.08	15.3
B10	0.68	353	36.6	14.1	10.5	6.91	17.5
CB101N	0.60	391	41.1	14.1	10.4	6.84	17.3
10WF, CB101	0.58	359	39.9	14.1	10.2	6.69	17.2
10WF, B10	0.61	359	39.1	14.1	10.2	6.69	17.2
B10	0.62	334	37.2	14.0	10.0	6.59	16.9
B10	0.53	279	36.9	14.4	8.53	5.32	15.5
B10	0.53	269	36.2	14.2	8.77	5.57	15.4
B10	0.47	291	39.9	13.9	8.92	5.90	15.2
B10	0.48	297	40.1	13.9	9.05	5.99	15.3
CB101N	0.42	337	45.4	13.9	9.05	5.99	15.3
10WF, CB101	0.43	313	43.6	13.9	9.05	5.99	15.3
10WF, B10	0.45	313	42.6	13.9	9.05	5.99	15.3

Table 2.3.2 Torsion Properties -- Steel Sections 1887-1952

Designation	Torsional Constant	Warping Constant		Normalized Warping Constant	Warping Statical Moment	Statical Moment	Statical Moment
	J	Cw	(ECw/GJ) ^{1/2} = a	Wno	Sw	Qf	Qw
	in.4	in.6	in.	in.2	in.4	in.3	in.3
CB101	0.39	367	49.2	14.6	9.44	6.00	15.3
B10	0.47	291	39.9	13.9	8.92	5.90	15.2
10WF, B10	0.40	296	43.9	13.9	8.61	5.72	14.6
10WF, CB101	0.38	296	45.1	13.9	8.61	5.72	14.6
----	0.34	223	41.4	14.0	7.67	4.92	14.1
B10	0.43	255	39.2	14.0	8.51	5.57	14.3
B10	0.36	251	42.7	13.8	7.93	5.27	13.7
B10	0.36	258	43.1	14.0	8.13	5.32	13.8
B10	0.36	251	42.7	13.8	7.93	5.27	13.7
10WF, B10	0.31	261	46.8	13.8	7.74	5.16	13.3
10WF, CB101	0.29	261	48.3	13.8	7.74	5.16	13.3
CB101	0.27	317	54.6	14.4	8.25	5.29	13.4
CB101N	0.29	286	50.8	13.8	7.74	5.16	13.3
B10	0.33	245	43.8	13.8	7.74	5.16	13.3
10WF	0.34	223	41.0	13.6	7.63	5.08	13.1
B10	0.39	248	40.5	13.9	8.36	5.57	13.6
B67	0.30	208	42.4	13.2	6.89	4.78	12.7
B67	0.30	208	42.4	13.2	6.89	4.78	12.7
B37	0.45	146	28.9	11.1	6.01	4.89	12.7
B26	0.33	158	35.3	12.0	6.00	4.56	12.2
B10	0.26	212	46.0	13.7	6.87	4.59	12.1
B10	0.25	210	46.4	13.7	6.82	4.55	12.0
10WF, B10	0.23	222	50.0	13.7	6.72	4.48	11.9
10WF, CB101	0.21	222	52.0	13.7	6.72	4.48	11.9
CB101N	0.21	247	55.2	13.7	6.72	4.48	11.9
----	0.26	211	45.7	13.7	7.36	4.91	12.8
CB101	0.20	275	59.7	14.4	7.15	4.58	12.0
CB93	1.55	1381	48.0	19.6	26.4	11.1	26.4
G9	1.47	936	40.6	18.2	22.4	10.1	23.8
G9	1.47	936	40.6	18.2	22.4	10.1	23.8
CB93	1.13	1207	52.6	19.4	23.3	9.90	23.5
G9	1.08	799	43.9	18.0	19.8	8.96	21.0
G9	1.08	799	43.9	18.0	19.8	8.96	21.0
G9	1.14	793	42.4	18.0	19.9	9.00	21.3
G9	1.22	731	39.5	18.0	20.0	9.08	21.1
CB93	0.79	1039	58.2	19.2	20.3	8.70	20.6
G9	0.91	733	45.6	17.9	18.4	8.40	19.7
G9	0.91	733	45.6	17.9	18.4	8.40	19.7
CB92	0.99	495	35.9	14.1	13.1	7.59	18.7
CB92	0.77	441	38.5	14.0	11.8	6.91	17.0
CB92	0.58	391	41.7	13.9	10.6	6.24	15.3
B40	0.43	163	31.2	11.6	6.02	4.16	12.2
B9	0.39	164	33.1	12.0	6.03	4.06	11.8
B9	0.38	158	32.8	11.8	6.22	4.27	11.7

Table 2.3.2 Torsion Properties -- Steel Sections 1887-1952

Designation	Torsional Constant	Warping Constant	$(EC_w/GJ)^{1/2}$	Normalized Warping Constant	Warping Statical Moment	Statical Moment	Statical Moment
	J	C _w	a	W _{no}	S _w	Q _f	Q _w
	in.4	in.6	in.	in.2	in.4	in.3	in.3
B40N	0.36	156	33.7	11.4	5.88	4.16	11.5
B9	0.35	192	37.5	11.4	6.15	4.45	11.6
B9	0.33	177	37.5	11.9	6.41	4.43	11.5
B9	0.33	177	37.5	11.9	6.41	4.43	11.5
B9	0.33	152	34.8	11.7	6.09	4.27	11.1
B40	0.30	150	36.1	11.3	5.73	4.16	10.9
B9	0.27	159	39.3	11.9	5.87	4.08	10.7
B9	0.27	159	39.3	11.9	5.87	4.08	10.7
B40	0.29	148	36.6	11.3	5.70	4.16	10.7
B9	0.27	153	38.1	11.7	5.78	4.06	10.6
B9	0.27	153	38.1	11.7	5.78	4.06	10.6
B40N	0.28	147	37.0	11.2	5.67	4.16	10.5
B9	0.24	155	40.8	11.9	5.68	3.96	10.3
B9	0.29	147	36.3	11.6	5.96	4.27	10.5
G8	1.07	558	36.7	15.2	16.1	7.68	18.1
G8	1.07	562	36.8	15.2	16.2	7.76	18.1
CB83	0.83	643	44.7	15.5	15.5	7.41	17.6
8WF, B8b	0.77	618	45.6	15.3	15.1	7.25	17.1
8WF, CB83	0.77	618	45.6	15.3	15.1	7.25	17.1
CB83N	0.78	626	45.6	15.4	15.2	7.28	17.2
CB83N	0.65	581	47.9	15.3	14.2	6.82	16.1
8WF, CB83	0.64	573	48.0	15.2	14.1	6.78	16.0
8WF, B8b	0.64	573	48.0	15.2	14.1	6.78	16.0
G8	0.79	476	39.6	15.1	14.2	6.83	16.0
G8	0.78	471	39.6	15.1	14.0	6.75	15.9
G8	0.79	467	39.0	15.1	14.1	6.80	15.9
G8	0.88	429	35.5	15.1	14.2	6.85	15.9
8WF, CB83	0.53	530	50.7	15.1	13.1	6.32	14.9
8WF, B8b	0.53	530	50.7	15.1	13.1	6.32	14.9
CB83N	0.54	534	50.6	15.3	13.1	6.32	15.0
G8	0.66	429	41.1	15.0	13.0	6.29	14.9
8WF	0.89	256	27.3	12.4	9.38	5.27	13.8
CB82N	0.67	347	36.6	12.6	10.3	6.00	14.5
G8	0.57	396	42.3	14.9	12.2	5.91	14.0
8WF, B8a	0.53	312	38.9	12.4	9.40	5.50	13.3
8WF, CB82	0.53	312	38.9	12.4	9.40	5.50	13.3
----	0.46	258	38.0	12.7	7.90	4.47	12.1
8WF, CB82N	0.49	304	39.9	12.5	9.15	5.38	12.9
8WF, CB82	0.48	299	40.1	12.4	9.05	5.31	12.8
8WF, B8a	0.48	299	40.1	12.4	9.05	5.31	12.8
8WF	0.58	235	32.3	12.1	8.90	5.27	12.4
8WF, CB82	0.34	258	44.1	12.2	7.92	4.69	11.3
8WFB8a	0.34	258	44.1	12.2	7.92	4.69	11.3
CB82N	0.36	264	43.9	12.4	8.03	4.76	11.4

Table 2.3.2 Torsion Properties -- Steel Sections 1887-1952

Designation	Torsional Constant	Warping Constant	$(EC_w/GJ)^{1/2}$	Normalized Warping Constant	Warping Statical Moment	Statical Moment	Statical Moment
	J	C _w	a	W _{no}	S _w	Q _f	Q _w
	in.4	in.6	in.	in.2	in.4	in.3	in.3
8WF	0.38	110	27.3	10.3	4.90	3.38	9.76
----	0.35	110	28.6	10.3	4.90	3.38	9.76
B8	0.33	100	27.8	10.3	4.65	3.23	9.34
B8	0.33	130	32.2	10.3	5.42	3.91	10.0
8WF, B8	0.31	138	34.1	10.3	5.45	3.94	10.0
8WF, CB81	0.29	138	35.1	10.3	5.45	3.94	10.0
B39	0.31	97	28.6	9.78	4.27	3.11	9.10
8WF, B8	0.26	128	35.4	10.2	5.09	3.68	9.42
8WF, CB81	0.25	128	36.5	10.2	5.09	3.68	9.42
B8	0.26	98.9	31.7	10.2	4.32	3.05	8.70
B8	0.24	107	33.8	10.2	4.61	3.32	8.83
B8	0.24	107	33.8	10.2	4.61	3.32	8.83
B8	0.24	110	34.5	10.2	4.69	3.40	8.84
8WF, B8	0.23	118	36.8	10.2	4.73	3.43	8.85
8WF, CB81	0.21	118	38.1	10.2	4.73	3.43	8.85
B39N	0.24	92.4	31.8	9.64	4.15	3.11	8.52
8WF	0.24	101	32.7	10.0	4.64	3.38	8.60
----	0.22	101	34.5	10.0	4.64	3.38	8.60
B8	0.24	94.0	32.0	10.1	4.46	3.23	8.46
B39	0.21	89.4	33.1	9.57	4.09	3.11	8.22
B8	0.19	94.4	35.8	10.1	4.16	3.02	8.03
B8	0.20	94.4	35.2	10.1	4.20	3.05	8.10
B38	0.30	64.8	23.8	8.21	3.66	3.22	8.11
B8	0.19	94.4	35.8	10.1	4.16	3.02	8.03
B39	0.20	88.0	33.7	9.54	4.06	3.11	8.07
B68	0.20	90.7	34.3	9.56	4.17	3.19	8.13
B68	0.20	90.7	34.3	9.56	4.17	3.19	8.13
B8	0.17	91.2	37.1	10.1	4.04	2.94	7.77
8WF, B8	0.16	99.4	39.8	10.1	4.08	2.97	7.79
8WF, CB81	0.15	99.4	41.5	10.1	4.08	2.97	7.79
B39	0.19	88.0	34.6	9.5	4.03	3.11	7.92
B8	0.20	89.6	34.0	9.9	4.34	3.23	7.90
8x51/4	0.41	105	25.7	10.5	4.38	2.93	9.55
8x51/4	0.29	101	29.7	10.4	4.27	2.94	8.92
8x51/4	0.22	95.5	33.3	10.2	4.15	2.93	8.35
8x51/4	0.17	91.2	36.9	10.1	4.04	2.93	7.79
8x61/4	0.48	252	37.0	12.6	8.26	4.73	12.3
8x61/4	0.38	239	40.6	12.4	7.99	4.73	11.4
----	0.57	489	47.3	15.0	13.0	6.31	15.1
B6	2.02	275	18.8	9.37	11.0	6.47	15.8
B6	0.84	181	23.6	8.87	7.64	4.72	11.2
6WF, B6	0.62	170	26.5	9.11	6.96	4.29	10.4

Table 2.3.2 Torsion Properties -- Steel Sections 1887-1952

Designation	Torsional Constant	Warping Constant	(EC_w/GJ) ^{1/2} =	Normalized Warping Constant	Warping Statical Moment	Statical Moment	Statical Moment
	J	C _w	a	W _{no}	S _w	Q _f	Q _w
	in.4	in.6	in.	in.2	in.4	in.3	in.3
CBS6	0.61	169	26.7	9.11	6.96	4.29	10.4
6WF, B6	0.65	160	25.3	8.77	6.86	4.26	10.2
B6	0.60	155	25.8	8.75	6.65	4.13	9.90
6WF, B6	0.47	150	28.6	8.99	6.23	3.88	9.39
CBS6	0.46	150	28.9	8.99	6.23	3.88	9.39
CBS6	0.46	150	28.9	8.99	6.23	3.88	9.39
6WF, B6	0.49	142	27.3	8.65	6.16	3.87	9.18
B6	0.39	128	29.3	8.56	5.61	3.55	8.40
6WF, B6	0.35	131	31.2	8.88	5.52	3.47	8.38
6x6	0.34	96.4	27.0	8.52	4.87	3.01	7.72
CBS6	0.34	131	31.5	8.88	5.52	3.47	8.38
6WF, B6	0.36	125	29.8	8.54	5.46	3.47	8.19
----	0.31	96.5	28.5	8.53	4.85	3.00	7.69
BS6	0.27	109	32.4	8.83	4.80	3.01	7.46
6WF, B6	0.25	113	34.3	8.78	4.85	3.08	7.40
6WF, B6	0.26	107	32.8	8.44	4.75	3.03	7.19
CBS6	0.24	113	34.7	8.78	4.85	3.08	7.40
CBS6	0.24	113	34.7	8.78	4.85	3.08	7.40
6x6	0.26	90.1	30.0	8.35	4.68	3.02	7.17
BS6	0.18	91.9	35.9	8.71	4.12	2.61	6.48
6WF, B6	0.18	98.0	37.6	8.70	4.21	2.68	6.53
6WF, B6	0.18	91.9	36.0	8.37	4.11	2.63	6.33
CBS6	0.17	97.2	38.0	8.70	4.21	2.68	6.53
BS6	0.18	91.7	36.7	8.70	4.11	2.61	6.45
CBS6	0.17	91.7	37.3	8.70	4.11	2.61	6.45
6WF, B6	0.12	79.6	42.0	8.60	3.47	2.22	5.52
BS6	0.12	75.5	40.1	8.60	3.47	2.22	5.52
CBS6	0.11	79.6	42.7	8.60	3.47	2.22	5.52
CBS6	0.11	75.5	41.6	8.60	3.47	2.22	5.52
BS6	0.12	75.5	40.8	8.60	3.47	2.22	5.52
CBS6	0.11	75.5	41.6	8.60	3.47	2.22	5.52
6WF, B6	0.12	73.9	40.5	8.27	3.34	2.14	5.29
5X5	0.31	40.9	18.4	5.73	2.99	2.24	5.47
H2	0.31	41.0	18.4	5.73	2.99	2.24	5.46
BS5, H2	0.35	41.0	17.5	5.73	2.98	2.24	5.45
5WF, B5	0.30	49.1	20.8	5.90	3.12	2.35	5.57
CB51	0.30	49.1	20.8	5.90	3.12	2.35	5.57
5WF, B5	0.19	40.4	23.3	5.80	2.61	1.99	4.73
CB51	0.19	40.4	23.3	5.80	2.61	1.99	4.73
5WF, B5	0.11	31.6	26.7	5.70	2.08	1.59	3.85
4x4	0.18	11.9	12.9	3.64	1.31	1.21	3.05
H1	0.22	11.8	11.8	3.63	1.35	1.24	3.11

Table 2.3.2 Torsion Properties -- Steel Sections 1887-1952

Designation	Torsional Constant	Warping Constant	$(EC_w/GJ)^{1/2}$	Normalized Warping Constant	Warping Statical Moment	Statical Moment	Statical Moment
	J	C _w	a	W _{no}	S _w	Q _f	Q _w
	in.4	in.6	in.	in.2	in.4	in.3	in.3
BS4	0.16	13.7	15.1	3.87	1.36	1.24	3.09
H1	0.17	11.2	13.0	3.57	1.31	1.24	2.99
4x4	0.17	10.9	12.9	3.57	1.31	1.24	2.99
BS4, CB41	0.08	9.6	18.1	3.74	0.99	0.94	2.31
BS4	0.03	6.60	22.6	3.62	0.72	0.69	1.71
12BL, B12L	0.30	161	37.5	12.0	5.12	4.75	14.4
CBL12	0.29	161	37.8	12.0	5.12	4.75	14.4
BJ12	0.28	149	37.2	12.2	5.04	4.58	13.8
12BL, B12L	0.19	128	42.1	11.8	4.14	3.89	12.2
CBL12	0.18	128	42.5	11.8	4.14	3.89	12.2
BJ12	0.18	114	40.9	12.0	3.99	3.64	11.6
12BL, B12L	0.11	96.0	46.5	11.7	3.16	2.97	10.1
CBL12	0.11	96.0	47.2	11.7	3.16	2.97	10.1
12BJ, BJ12	0.07	76.8	52.4	11.6	2.58	2.47	8.48
CBJ12	0.07	76.8	53.3	11.6	2.58	2.47	8.48
Jr12	0.05	34.0	40.8	9.01	1.55	1.92	6.98
Jr12	0.05	34.0	40.9	9.02	1.55	1.91	6.98
Jr11	0.04	21.8	36.8	7.67	1.17	1.55	5.60
10BL, B10L	0.24	102	33.4	9.91	3.92	3.66	10.6
CBL10	0.23	102	33.7	9.91	3.92	3.66	10.6
BJ10	0.26	92.9	30.6	9.79	3.91	3.66	10.5
10BL, B10L	0.16	82.7	36.7	9.82	3.24	3.04	9.14
CBL10	0.16	82.7	37.2	9.82	3.24	3.04	9.14
BJ10	0.16	70.8	33.8	9.68	3.08	2.90	8.80
10BL, B10L	0.11	66.0	40.0	9.73	2.62	2.47	7.81
CBL10	0.10	66.0	40.6	9.73	2.62	2.47	7.81
10BJ, BJ10	0.05	46.9	48.8	9.55	1.92	1.86	5.91
CBJ10	0.05	46.9	49.9	9.55	1.92	1.86	5.91
Jr10	0.03	14.6	33.7	6.58	0.92	1.29	4.51
Jr9	0.02	7.56	28.4	5.23	0.60	0.95	3.37
BJ8	0.21	49.6	25.0	7.50	2.73	2.64	7.26
8BL, B8L	0.14	50.3	30.5	7.84	2.47	2.31	6.64
CBL8	0.14	50.3	31.0	7.84	2.47	2.31	6.64
BJ8	0.14	40.3	26.9	7.44	2.28	2.20	6.33
8BL, B8L	0.09	39.3	33.7	7.75	1.97	1.85	5.55
CBL8	0.09	39.3	34.3	7.75	1.97	1.85	5.55
8BJ, BJ8	0.04	29.5	41.5	7.58	1.52	1.48	4.29
CBJ8	0.04	29.5	42.5	7.58	1.52	1.48	4.29
Jr8	0.02	5.19	26.1	4.45	0.48	0.79	2.66

Table 2.3.2 Torsion Properties -- Steel Sections 1887-1952

Designation	Torsional Constant	Warping Constant	(EC_w/GJ) ^{1/2} =	Normalized Warping Constant	Warping Statical Moment	Statical Moment	Statical Moment
	J	C _w	a	W _{no}	S _w	Q _f	Q _w
	in.4	in.6	in.	in.2	in.4	in.3	in.3
B7	0.11	23.4	23.3	5.84	1.65	1.79	4.72
B42	0.12	23.3	22.2	5.83	1.70	1.84	4.82
Jr7	0.01	2.91	22.5	3.54	0.33	0.60	1.97
CBL6	0.22	36.9	20.8	5.89	2.40	2.23	5.72
B6L	0.23	36.9	20.6	5.89	2.40	2.23	5.72
BJ6	0.15	29.8	23.0	5.80	1.97	1.85	4.84
CBL6	0.09	23.6	26.1	5.72	1.60	1.50	4.04
B6L	0.09	23.6	25.8	5.72	1.60	1.50	4.04
BJ6	0.10	13.3	18.8	4.75	1.16	1.30	3.64
6B, B6b	0.09	10.5	17.6	4.27	0.99	1.24	3.33
B41	0.09	10.5	17.0	4.26	1.02	1.27	3.39
B108	0.07	9.8	18.8	4.19	0.89	1.14	3.12
BJ6	0.03	15.0	33.5	5.55	1.06	1.03	2.78
CBJ6	0.03	15.0	34.3	5.55	1.06	1.03	2.78
Jr6	0.01	1.44	18.6	2.69	0.21	0.43	1.38
H16	339	139917	32.7	64.6	819	173	428
H16	308	132425	33.4	64.0	783	166	411
H16	279	125206	34.1	63.3	748	160	394
H16	252	118208	34.9	62.7	713	154	378
H16	227	111471	35.7	62.1	680	148	362
H16b	205	105562	36.5	62.2	642	135	344
H16	203	104962	36.6	61.5	647	142	346
H16	200	101206	36.2	61.1	626	136	340
H16	182	98703	37.5	60.9	615	135	330
H16	179	94977	37.1	60.5	595	130	324
H16	162	92644	38.5	60.3	583	129	315
H16	159	89052	38.1	59.9	564	124	309
H16	143	86818	39.6	59.7	553	124	300
H16	140	83311	39.2	59.3	533	118	294
H16	126	81358	40.8	59.1	523	118	285
H16	124	78063	40.4	58.8	504	112	279
H16a	111	75595	42.0	59.2	485	106	267
H16	111	76095	42.1	58.6	494	112	271
H16	108	72717	41.7	58.2	475	107	265
H16	96.7	70869	43.6	58.0	466	106	256
H16	94.4	67600	43.1	57.6	447	101	250
H16	87.9	67497	44.6	57.6	447	102	246
H16	85.7	64364	44.1	57.2	429	97.4	241
H16	79.6	64216	45.7	57.2	428	98.7	237
H16	77.6	61137	45.2	56.8	410	93.7	232
H16	71.9	61015	46.9	56.8	410	95.0	228
H16	70.0	58045	46.3	56.4	393	90.1	222
H16	64.7	57903	48.1	56.4	392	91.3	218

Table 2.3.2 Torsion Properties -- Steel Sections 1887-1952

Designation	Torsional Constant	Warping Constant	$(EC_w/GJ)^{1/2}$	Normalized Warping Constant	Warping Statical Moment	Statical Moment	Statical Moment
	J	C _w	a	W _{no}	S _w	Q _f	Q _w
	in.4	in.6	in.	in.2	in.4	in.3	in.3
H16	62.9	54969	47.6	56.0	375	86.5	213
H16	58.2	54977	49.4	56.0	375	87.6	210
H16	56.6	52165	48.8	55.7	358	82.9	205
H16	52.2	52121	50.8	55.7	358	84.0	201
H16	50.5	49234	50.2	55.2	341	79.3	196
H16	46.4	49241	52.4	55.3	341	80.4	192
H16	44.9	46467	51.8	54.9	324	75.8	187
H16	41.1	46435	54.1	54.9	324	76.8	183
H16	39.7	43725	53.4	54.5	308	72.3	178
H16	36.2	43707	55.9	54.5	308	73.3	174
H16	34.9	41089	55.2	54.1	291	68.9	170
H16	31.7	41051	57.9	54.1	292	69.7	166
H16	30.5	38484	57.1	53.7	275	65.4	161
H16	27.6	38476	60.1	53.7	276	66.3	157
H16	23.8	35965	62.5	53.4	260	62.8	149
H16	20.5	33532	65.1	53.0	244	59.4	141
H16	17.4	31167	68.0	52.6	229	56.0	132
H16	14.7	28869	71.3	52.2	214	52.6	124
H14d	331	144738	33.7	65.4	828	176	434
CB146N	332	144707	33.6	65.4	828	176	434
14WF	330	144603	33.7	65.3	827	176	434
CB146	337	137314	32.5	63.8	805	172	427
CB146N	302	137174	34.3	64.8	792	169	417
14WF	300	137126	34.4	64.8	792	169	417
CB146	295	127187	33.4	62.9	756	164	403
H14d	273	129883	35.1	64.2	757	163	400
CB146N	274	129883	35.1	64.2	757	163	400
14WF	272	129763	35.1	64.1	756	163	400
CB146	256	117433	34.5	62.0	708	155	380
14WF	246	122763	35.9	63.6	722	157	384
CB146N	247	122781	35.9	63.6	722	157	384
H14d	222	116063	36.8	63.0	689	150	368
CB146N	223	116040	36.7	63.0	689	150	368
14WF	222	115952	36.8	62.9	689	150	368
CB146	220	108104	35.6	61.2	661	146	357
CB146N	200	109349	37.6	62.4	656	144	352
14WF	199	109308	37.7	62.3	656	144	351
CB146	188	99175	36.9	60.3	615	137	335
14WF	178	102889	38.7	61.7	623	138	336
CB146N	178	102889	38.6	61.7	623	138	336
H14d	158	96781	39.8	61.1	592	132	320
CB146N	159	96759	39.7	61.1	592	132	320
14WF	158	96691	39.8	61.1	592	132	320
CB146	159	90614	38.4	59.4	571	129	312

Table 2.3.2 Torsion Properties -- Steel Sections 1887-1952

Designation	Torsional Constant	Warping Constant	$(EC_w/GJ)1/2=$	Normalized Warping Constant	Warping Statical Moment	Statical Moment	Statical Moment
	J	Cw	a	Wno	Sw	Qf	Qw
	in.4	in.6	in.	in.2	in.4	in.3	in.3
14WF	137	88537	40.9	61.5	538	114	295
CB146N	138	88531	40.8	61.5	538	114	295
H14d	140	90721	41.0	60.5	561	126	305
CB146N	141	90715	40.9	60.5	561	126	305
14WF	140	90632	41.0	60.5	561	126	304
CB146	133	82469	40.1	58.6	527	120	290
H14d	123	84879	42.3	59.9	530	120	289
CB146N	124	84862	42.2	59.9	530	120	289
14WF	123	84796	42.3	59.9	530	120	289
H14	131	75250	38.6	57.1	500	117	283
CB146	121	78524	41.0	58.1	506	116	280
H14b	128	69079	37.4	55.5	473	113	276
H14	120	71935	39.4	56.7	482	113	273
H14	126	65640	36.7	54.5	457	111	272
H14	126	65640	36.7	54.5	457	111	272
CB146N	109	79451	43.5	59.4	501	114	275
14WF	108	79407	43.6	59.3	501	114	275
CB146	110	74696	42.0	57.7	485	112	269
H14b	118	65982	38.1	55.1	455	109	267
H14	110	68706	40.3	56.3	464	109	264
H14	116	62687	37.4	54.1	440	107	263
H14	116	62687	37.4	54.1	440	107	263
CB146	99	70910	43.1	57.3	464	107	258
H14b	108	63053	38.9	54.7	438	106	258
14WF	93.8	73986	45.2	58.7	472	108	260
CB146N	94.2	73986	45.1	58.7	472	108	260
14WF	93.6	73917	45.2	58.7	471	108	259
H14	100	65555	41.1	55.9	446	106	255
H14	106	59894	38.2	53.7	423	104	254
H14	106	59894	38.2	53.7	423	104	254
H14	98.5	60111	39.8	54.3	421	102	248
CB146	89.1	67244	44.2	56.8	443	103	248
14WF	85.3	70571	46.3	58.3	453	105	250
CB146N	85.7	70587	46.2	58.3	453	105	250
H14	97.1	57092	39.0	53.3	407	100	245
H14	91.3	62492	42.1	55.5	428	102	245
H14	97.1	57092	39.0	53.3	407	100	245
H14b	89.7	57327	40.7	53.9	404	99	240
CB146	79.8	63675	45.4	56.4	423	99	237
CB146N	77.5	67179	47.4	58.0	434	101	240
14WF	77.1	67152	47.5	58.0	434	101	240
H14	83.0	59501	43.1	55.2	411	98	236
H14	88.5	54446	39.9	53.0	391	97	236

Table 2.3.2 Torsion Properties -- Steel Sections 1887-1952

Designation	Torsional Constant	Warping Constant	$(EC_w/GJ)_{1/2}$	Normalized Warping Constant	Warping Statical Moment	Statical Moment	Statical Moment
	J	C _w	a	W _{no}	S _w	Q _f	Q _w
	in.4	in.6	in.	in.2	in.4	in.3	in.3
H14	88.5	54446	39.9	53.0	391	97	236
H14b	81.5	54537	41.6	53.5	388	95	230
CB146N	70.1	63940	48.6	57.6	416	97	231
14WF	69.7	63914	48.7	57.5	416	97	231
H14	80.4	51791	40.8	52.6	375	94	227
CB146	71.2	60187	46.8	55.9	403	95	227
H14	75.1	56595	44.2	54.8	394	95	227
H14	80.4	51791	40.8	52.6	375	94	227
H14b	73.8	51899	42.7	53.2	372	92	222
14WF	62.6	60665	50.1	57.2	397	93	222
CB146N	62.9	60675	50.0	57.2	397	93.1	222
H14	72.8	49277	41.9	52.2	359	90.1	218
H14	67.8	53763	45.3	54.4	377	91.2	218
H14	72.8	49277	41.9	52.2	359	90.1	218
CB146	63.2	56780	48.2	55.5	383	90.8	216
H14b	66.6	49260	43.8	52.8	356	88.3	213
H14	65.7	46769	42.9	51.9	344	86.7	210
14WF	56.2	57599	51.5	56.8	380	89.5	212
CB146N	56.4	57594	51.4	56.8	380	89.5	212
H14	65.7	46769	42.9	51.9	344	86.7	210
H14	60.9	51005	46.5	54.0	360	87.7	209
CB146	55.8	53459	49.8	55.1	364	86.6	206
H14a	59.9	46760	44.9	52.4	340	84.9	204
H14	59.1	44389	44.1	51.5	329	83.4	201
H14	59.1	44389	44.1	51.5	329	83.4	201
H14d	50.0	54509	53.1	56.4	362	85.7	203
CB146N	50.3	54509	53.0	56.4	362	85.7	203
H14	54.6	48324	47.9	53.6	344	84.2	200
14WF	49.9	54459	53.2	56.4	362	85.7	203
CB146	49.0	50244	51.5	54.6	344	82.6	196
H14a	53.9	44356	46.1	52.1	325	81.5	196
H14	53.0	42013	45.3	51.1	314	80.0	193
14WF	44.8	51757	54.7	56.0	346	82.2	195
H14	53.0	42013	45.3	51.1	314	80.0	193
CB146N	45.0	51757	54.6	56.0	346	82.2	195
H14	48.7	45714	49.3	53.3	328	80.7	192
H14a	48.1	41983	47.5	51.7	310	78.2	187
CB146	42.7	47097	53.4	54.2	326	78.5	186
H14	47.5	39846	46.6	50.8	299	76.8	185
H14	47.5	39846	46.6	50.8	299	76.8	185
H14	43.4	43261	50.8	52.9	313	77.2	183
14WF	39.6	48880	56.5	55.6	329	78.7	186
CB146N	39.8	48885	56.4	55.6	329	78.7	186
H14a	42.8	39617	49.0	51.3	295	74.8	179

Table 2.3.2 Torsion Properties -- Steel Sections 1887-1952

Designation	Torsional Constant	Warping Constant	$(EC_w/GJ)_{1/2}$	Normalized Warping Constant	Warping Statical Moment	Statical Moment	Statical Moment
	J	C _w	a	W _{no}	S _w	Q _f	Q _w
	in.4	in.6	in.	in.2	in.4	in.3	in.3
H14	42.2	37598	48.0	50.4	285	73.4	176
H14	42.2	37598	48.0	50.4	285	73.4	176
CB146	37.0	44042	55.5	53.8	307	74.4	176
H14	38.4	40784	52.4	52.5	297	73.8	175
CB146N	34.9	46004	58.4	55.2	312	74.9	177
14WF	34.7	45979	58.6	55.2	312	74.9	177
H14a	37.8	37373	50.6	51.0	281	71.5	171
H14	37.3	35463	49.6	50.1	271	70.2	168
H14	37.3	35463	49.6	50.1	271	70.2	168
H14	33.8	38380	54.2	52.2	282	70.4	166
CB146	31.8	41065	57.8	53.3	289	70.4	166
H14d	30.4	43309	60.7	54.8	296	71.5	168
CB146N	30.6	43309	60.5	54.8	296	71.5	168
14WF	30.3	43265	60.8	54.8	296	71.5	168
H14a	33.3	35136	52.3	50.6	266	68.2	163
H14	32.8	33340	51.3	49.7	257	67.0	160
H14	32.8	33340	51.3	49.7	257	67.0	160
H14	29.5	36042	56.2	51.8	267	67.0	158
CB146N	26.7	40703	62.8	54.5	280	67.8	159
14WF	26.5	40688	63.1	54.5	280	67.8	159
CB146	27.1	38171	60.4	52.9	270	66.4	156
H14a	29.1	33018	54.2	50.2	252	65.0	155
H14	28.7	31327	53.1	49.3	243	63.8	152
H14	28.7	31327	53.1	49.3	243	63.8	152
H14	25.7	33770	58.3	51.4	253	63.7	150
CB146N	22.9	38029	65.5	54.1	263	64.1	151
14WF	22.8	38015	65.8	54.1	263	64.1	151
CB146	22.9	35360	63.3	52.4	253	62.4	146
H14a	25.3	30910	56.2	49.9	238	61.7	146
H14	25.0	29325	55.1	49.0	230	60.6	144
H14	25.0	29278	55.1	49.0	230	60.6	144
H14	25.0	29325	55.1	49.0	230	60.6	144
H14	22.4	31694	60.5	51.1	239	60.4	142
14WF	19.5	35531	68.7	53.7	248	60.8	142
CB146N	19.6	35531	68.4	53.7	248	60.8	142
H14	21.6	27410	57.3	48.6	217	57.4	136
CB146	19.1	32640	66.5	52.0	235	58.4	137
H14	21.6	27425	57.3	48.6	217	57.5	137
H14	21.6	27379	57.3	48.6	217	57.5	137
H14	21.6	27379	57.3	48.6	217	57.5	137
H14	18.9	30824	65.0	51.2	226	57.8	137
CB145N	19.0	30810	64.8	51.2	225	57.8	137
H14	16.8	33247	71.6	53.4	234	57.5	134

Table 2.3.2 Torsion Properties -- Steel Sections 1887-1952

Designation	Torsional Constant	Warping Constant	$(EC_w/GJ)1/2=$	Normalized Warping Constant	Warping Statical Moment	Statical Moment	Statical Moment
	J	C _w	a	W _{no}	S _w	Q _f	Q _w
	in.4	in.6	in.	in.2	in.4	in.3	in.3
CB146N	16.9	33247	71.4	53.4	234	57.5	134
14WF	16.7	33214	71.7	53.3	233	57.5	134
H14b	20.3	20576	51.3	49.4	161	39.1	113
H14b	20.3	20576	51.3	49.4	161	39.1	113
H14c	20.3	20567	51.3	49.4	161	39.1	113
H14	18.5	25545	59.7	48.2	204	54.3	129
H14	18.5	25494	59.7	48.2	204	54.3	129
H14	18.5	25494	59.7	48.2	204	54.3	129
H14	16.2	28779	67.9	50.8	212	54.6	129
CB146	15.7	29985	70.2	51.6	218	54.5	127
CB145N	16.3	28770	67.6	50.8	212	54.6	129
14WF	14.2	30915	75.0	53.0	218	53.9	126
CB146N	14.3	30850	74.8	53.0	218	53.8	126
H14	15.8	23734	62.4	47.9	191	51.2	121
H14	15.8	23751	62.5	47.9	191	51.2	121
H14	15.8	23696	62.4	47.9	191	51.2	121
14WF	13.5	26587	71.5	50.4	198	51.2	120
CB145N	13.6	26587	71.2	50.4	198	51.2	120
CB146	12.8	27397	74.5	51.1	201	50.5	118
H14	13.4	22029	65.3	47.6	179	48.2	114
H14	13.4	22025	65.3	47.6	179	48.2	114
CB146	10.8	24116	75.9	51.3	176	42.9	108
H14	13.4	21979	65.2	47.6	179	48.2	114
CB145N	11.2	24475	75.3	50.0	183	47.8	112
14WF	11.1	24475	75.6	50.0	183	47.9	112
CB146	10.2	24913	79.4	50.7	184	46.6	108
H14	11.2	20322	68.6	47.2	167	45.1	106
H14	11.2	20337	68.7	47.2	167	45.1	107
H14	11.2	20292	68.6	47.2	167	45.1	107
14WF	9.20	22614	79.8	49.7	171	44.8	105
CB145N	9.28	22609	79.4	49.7	171	44.8	105
H14	9.23	18670	72.4	46.9	155	42.1	99.2
H14	9.23	18666	72.4	46.9	155	42.1	99.2
CB146	8.04	22498	85.1	50.3	168	42.7	99.2
H14	9.23	18622	72.3	46.9	155	42.1	99.2
H14	9.23	18622	72.3	46.9	155	42.1	99.2
14WF	7.48	20717	84.7	49.3	157	41.5	96.9
CB145N	7.55	20708	84.3	49.3	157	41.5	96.9
H14	7.52	17069	76.6	46.5	143	39.1	91.9
H14	7.52	17082	76.7	46.5	143	39.1	92.0
H14	7.52	17034	76.6	46.5	143	39.1	92.0
H14	7.52	17034	76.6	46.5	143	39.1	92.0
CB146	6.34	20381	91.2	49.9	153	39.2	90.9
CB145N	8.84	13096	61.9	40.5	121	38.3	90.4

Table 2.3.2 Torsion Properties -- Steel Sections 1887-1952

Designation	Torsional Constant	Warping Constant	$(EC_w/GJ)^{1/2}$	Normalized Warping Constant	Warping Statical Moment	Statical Moment	Statical Moment
	J	C _w	a	W _{no}	S _w	Q _f	Q _w
	in.4	in.6	in.	in.2	in.4	in.3	in.3
CB145N	6.10	18949	89.7	49.0	145	38.4	89.5
14WF	6.02	18945	90.3	49.0	145	38.5	89.5
H14	6.05	15517	81.5	46.2	131	36.1	84.8
H14	6.05	15517	81.5	46.2	131	36.1	84.8
H14	6.05	15517	81.5	46.2	131	36.1	84.8
H14	6.05	15474	81.4	46.2	131	36.1	84.8
CB146N	4.75	18092	99.3	49.4	137	35.3	81.8
14WF	4.74	17152	96.8	48.6	132	35.2	82.0
CB145N	6.62	11565	67.2	40.0	108	34.5	81.2
CB145N	4.80	17152	96.2	48.6	132	35.2	82.0
H14s	5.76	12534	75.1	42.8	114	33.7	79.8
H14	4.78	14018	87.1	45.8	120	33.2	77.7
H14	4.78	14024	87.2	45.8	120	33.2	77.7
H14	4.78	14024	87.2	45.8	120	33.2	77.7
H14/12	5.49	10237	69.5	39.9	99.5	31.4	75.4
H14/12	5.49	10237	69.5	39.9	99.5	31.4	75.4
H14s	5.51	10045	68.7	39.7	98.2	31.2	75.2
CB145N	3.74	15493	104	48.3	120	32.2	74.8
14WF	3.68	15493	104	48.3	120	32.2	74.8
CB146	3.46	15890	109	49.0	122	31.5	72.8
CB145	4.80	10098	73.8	39.6	95.6	30.7	72.1
H14	3.71	12563	93.7	45.5	109	30.3	70.7
14WF	4.41	10126	77.1	40.3	94.2	30.2	71.7
H14a	4.41	10117	77.1	40.3	94.2	30.2	71.6
CB144N	4.47	10121	76.6	40.3	94.2	30.2	71.7
H14	3.71	12563	93.7	45.5	109	30.3	70.7
H14	3.71	12563	93.7	45.5	109	30.3	70.7
H14/12	4.34	9251	74.3	39.6	90.8	28.9	69.1
H14/12	4.34	9254	74.3	39.6	90.8	28.9	69.1
H14s	4.36	9081	73.4	39.4	89.7	28.7	69.0
H14s	3.53	9208	82.2	40.0	86.2	27.7	66.0
14WF	3.52	9208	82.3	40.0	86.2	27.7	66.0
CB144N	3.58	9208	81.6	40.0	86.2	27.7	66.0
H14s	4.13	7134	66.9	36.2	76.4	26.5	64.5
H14/12	3.38	8293	79.7	39.3	82.4	26.4	63.0
H14/12	3.38	8293	79.7	39.3	82.4	26.4	63.0
CB144	3.92	6216	64.1	34.3	67.9	25.7	63.5
14WF	3.86	5999	63.5	33.8	66.6	25.3	61.8
H14b	3.86	5995	63.4	33.8	66.5	25.2	61.8
CB143N	3.92	5995	63.0	33.8	66.5	25.2	61.8
H14/10	3.86	5544	61.0	33.2	64.5	24.3	59.9
H14/10	3.86	5544	61.0	33.2	64.5	24.3	60.0
H14s	3.22	6393	71.7	35.9	69.3	24.2	58.8
H14/12	2.57	7371	86.2	39.0	74.1	23.9	56.9

Table 2.3.2 Torsion Properties -- Steel Sections 1887-1952

Designation	Torsional Constant	Warping Constant	$(EC_w/GJ)^{1/2}$	Normalized Warping Constant	Warping Statical Moment	Statical Moment	Statical Moment
	J	C _w	a	W _{no}	S _w	Q _f	Q _w
	in.4	in.6	in.	in.2	in.4	in.3	in.3
H14/12	2.57	7377	86.3	39.0	74.2	23.9	56.9
H14b	3.01	5394	68.1	33.5	60.4	23.0	56.5
CB143N	3.06	5410	67.6	33.5	60.4	23.1	56.6
14WF	3.01	5394	68.1	33.5	60.4	23.0	56.4
CB144	2.95	5514	69.6	34.0	60.9	23.2	57.2
H14/10	3.01	4968	65.4	32.9	58.5	22.2	54.6
H14/10	3.01	4968	65.4	32.9	58.5	22.2	54.6
H14s	3.03	4895	64.6	32.7	58.0	22.1	54.6
H14/10	2.30	4415	70.6	32.6	52.7	20.2	49.4
H14/10	2.30	4418	70.6	32.6	52.7	20.2	49.4
H14b	2.19	4722	74.6	33.2	53.3	20.5	50.2
H14s	2.35	4372	69.5	32.5	52.3	20.1	49.7
CB144	2.16	4845	76.2	33.6	54.0	20.8	51.0
14WF	2.19	4722	74.7	33.2	53.3	20.5	50.2
CB143N	2.24	4722	73.9	33.2	53.3	20.5	50.2
H14/8	2.61	2650	51.3	26.5	38.5	18.0	46.1
H14/8	2.61	2650	51.3	26.5	38.5	18.0	46.1
14WF	2.49	2835	54.2	27.0	39.3	18.4	46.9
H14c	2.49	2830	54.2	27.0	39.2	18.4	46.8
CB143N	2.45	2872	55.1	27.3	39.4	18.5	47.5
CB142N	2.54	2830	53.7	27.0	39.2	18.4	46.9
H14s	2.19	3130	60.8	28.7	42.1	17.8	44.7
H14/10	1.71	3884	76.7	32.3	47.0	18.1	44.2
H14/10	1.71	3884	76.7	32.3	47.0	18.1	44.2
H14/8	2.00	2355	55.3	26.2	34.6	16.3	41.7
H14/8	2.00	2357	55.3	26.2	34.6	16.3	41.7
CB143	1.90	2575	59.3	27.0	35.6	16.9	43.2
14WF	1.93	2536	58.3	26.8	35.5	16.8	42.6
H14c	1.93	2536	58.3	26.8	35.5	16.8	42.6
CB142N	1.97	2536	57.7	26.8	35.5	16.8	42.6
H14s	1.65	2868	67.2	29.1	38.4	16.4	41.1
CB143	1.43	2282	64.3	26.8	31.9	15.3	38.9
H14c	1.44	2236	63.3	26.5	31.6	15.1	38.2
H14/8	1.49	2070	59.9	25.9	30.8	14.7	37.3
14WF	1.44	2240	63.4	26.5	31.6	15.1	38.2
CB142N	1.48	2236	62.5	26.5	31.6	15.1	38.2
H14/8	1.49	2070	59.9	25.9	30.8	14.7	37.3
H14s	1.54	2070	59.1	25.9	30.8	14.6	37.7
H14c	1.05	1950	69.3	26.3	27.8	13.4	34.0
14WF	1.05	1950	69.5	26.3	27.8	13.4	33.9
CB142N	1.08	1950	68.4	26.3	27.8	13.4	34.0
H14/8	1.08	1799	65.6	25.7	27.2	13.1	33.1
H14/8	1.08	1800	65.6	25.7	27.2	13.1	33.1

Table 2.3.2 Torsion Properties -- Steel Sections 1887-1952

Designation	Torsional Constant	Warping Constant	$(EC_w/GJ)^{1/2}$	Normalized Warping Constant	Warping Statical Moment	Statical Moment	Statical Moment
	J	C _w	a	W _{no}	S _w	Q _f	Q _w
	in.4	in.6	in.	in.2	in.4	in.3	in.3
H15s	1.12	1800	64.6	25.7	27.2	13.0	33.5
H13b	127	59815	35.0	51.7	439	105	255
H13b	116	57132	35.7	51.3	423	102	246
H13b	106	54518	36.4	50.9	407	98.4	237
H13b	97.2	51972	37.2	50.5	391	95.0	229
H13b	88.5	49498	38.1	50.2	375	91.7	220
H13b	80.4	47090	38.9	49.8	360	88.4	212
H13b	72.8	44746	39.9	49.4	345	85.1	204
H13b	65.7	42467	40.9	49.1	330	81.9	196
H13a	63.6	37854	39.2	47.2	305	78.6	189
H13a	57.2	35868	40.3	46.8	292	75.6	181
H13a	51.5	34016	41.4	46.5	279	72.5	174
H13a	45.9	32140	42.6	46.2	266	69.5	166
H13a	40.8	30320	43.9	45.8	253	66.5	159
H13a	36.1	28552	45.3	45.5	240	63.5	151
H13a	31.8	26838	46.8	45.1	228	60.6	144
H13a	27.8	25170	48.4	44.8	215	57.6	137
H13a	24.2	23559	50.2	44.4	204	54.7	130
H13	23.2	20319	47.6	42.2	184	52.0	124
H13	20.1	18963	49.4	41.9	174	49.3	117
H13c	19.1	16464	47.3	44.7	142	35.2	101
H13	17.2	17652	51.5	41.6	163	46.6	111
H13	14.7	16379	53.8	41.2	153	43.9	104
H13	12.4	15187	56.2	40.9	143	41.3	97.8
H13	10.4	13993	59.1	40.6	133	38.6	91.4
H13	8.58	12840	62.2	40.3	123	36.0	85.0
H13	7.00	11724	65.9	39.9	114	33.5	78.8
H13	5.62	10646	70.0	39.6	105	30.9	72.6
H13s	5.34	8530	64.3	36.7	90.2	28.7	68.2
H13s	4.22	7694	68.7	36.4	82.3	26.4	62.5
H13s	4.03	6048	62.3	33.4	70.1	24.3	58.5
H13s	3.14	5415	66.9	33.1	63.5	22.2	53.3
H13s	2.96	4159	60.3	30.2	53.3	20.3	49.5
H13s	2.25	3692	65.2	30.0	47.9	18.4	44.7
H13s	2.11	2749	58.1	27.0	39.3	16.6	41.3
H13s	1.60	2422	62.6	26.8	35.1	15.0	37.2
H13s	1.49	1749	55.1	23.9	28.2	13.4	34.0
H13s	1.08	1517	60.3	23.7	24.8	11.9	30.1
H12b	119	44189	31.0	45.7	367	92.4	224
H12b	109	42161	31.6	45.3	353	89.3	217
H12b	100	40188	32.2	45.0	339	86.4	209
H12b	91.5	38274	32.9	44.6	326	83.4	201
H12b	83.4	36405	33.6	44.3	312	80.5	194

Table 2.3.2 Torsion Properties -- Steel Sections 1887-1952

Designation	Torsional Constant	Warping Constant	(EC_w/GJ) ^{1/2} =	Normalized Warping Constant	Warping Statical Moment	Statical Moment	Statical Moment
	J	C _w	a	W _{no}	S _w	Q _f	Q _w
	in.4	in.6	in.	in.2	in.4	in.3	in.3
H12b	75.7	34597	34.4	43.9	299	77.5	186
CB127	77.7	25189	29.0	38.7	243	56.3	148
H12b	68.5	32837	35.2	43.6	287	74.7	179
CB127	67.1	23929	30.4	38.0	235	56.3	144
H12b	61.8	31132	36.1	43.2	274	71.8	172
CB127	58.8	22722	31.6	37.4	227	56.3	139
H12b	55.6	29474	37.0	42.9	262	69.0	165
CB127	52.3	21566	32.7	36.8	220	56.3	135
H12a	53.3	25398	35.1	40.8	237	65.4	157
H12	51.1	21710	33.2	38.6	213	61.8	150
CB127	47.5	20455	33.4	36.1	212	56.3	131
CB125N	49.0	23573	35.3	40.1	220	63.7	155
12WF	48.9	23569	35.3	40.0	220	63.7	155
H12	51.1	21707	33.2	38.6	213	61.8	150
H12a	48.0	24058	36.0	40.5	226	62.7	151
H12	45.7	20513	34.1	38.3	203	59.3	144
H12	45.7	20505	34.1	38.3	203	59.3	144
H12a	42.8	22705	37.1	40.1	215	60.1	144
CB126	36.1	20059	37.9	39.4	190	46.4	120
12WF	39.1	21078	37.4	39.5	200	58.3	142
H12	41.0	19395	35.0	38.0	194	56.8	138
CB125N	39.2	21067	37.3	39.5	200	58.3	142
H12	41.0	19391	35.0	38.0	194	56.8	138
H12a	38.0	21391	38.2	39.8	205	57.5	138
CB126	30.0	19046	40.6	38.7	184	46.4	115
H12	34.8	19903	38.5	39.2	190	55.9	135
CB125N	34.9	19900	38.4	39.1	190	55.9	135
H12	36.4	18261	36.0	37.7	184	54.3	131
H12	36.4	18264	36.0	37.7	184	54.3	131
H12a	33.6	20118	39.3	39.5	194	54.9	131
H12	32.2	17172	37.1	37.4	175	51.9	125
H12	32.2	17172	37.1	37.4	175	51.9	125
12WF	30.6	18671	39.8	38.8	180	53.5	129
CB125N	30.6	18664	39.7	38.8	180	53.4	129
H12	32.2	17172	37.1	37.4	175	51.9	125
H12a	29.6	18886	40.7	39.2	184	52.3	125
CB126	25.9	18077	42.5	38.1	178	46.4	111
H12	28.4	16114	38.4	37.1	166	49.5	119
H12	28.4	16110	38.4	37.1	166	49.5	119
CB125N	26.9	17522	41.1	38.5	171	50.8	122
H12	26.8	17522	41.1	38.5	171	50.9	122
H12	28.4	16110	38.4	37.1	166	49.5	119
H12a	25.9	17690	42.1	38.8	174	49.8	118
CB126	23.0	17146	43.9	37.4	172	46.4	106

Table 2.3.2 Torsion Properties -- Steel Sections 1887-1952

Designation	Torsional Constant	Warping Constant	(EC_w/GJ) ^{1/2} =	Normalized Warping Constant	Warping Statical Moment	Statical Moment	Statical Moment
	J	C _w	a	W _{no}	S _w	Q _f	Q _w
	in.4	in.6	in.	in.2	in.4	in.3	in.3
H12	24.8	15092	39.7	36.8	157	47.1	113
H12	24.8	15089	39.7	36.8	157	47.1	113
12WF	23.4	16424	42.6	38.2	161	48.3	116
CB125N	23.5	16417	42.6	38.2	161	48.2	116
H12	24.8	15089	39.7	36.8	157	47.1	113
H12a	22.5	16534	43.6	38.5	164	47.3	112
H12	21.6	14100	41.1	36.5	148	44.7	107
H12	21.6	14097	41.1	36.5	148	44.7	107
H12	20.4	15393	44.2	37.9	152	45.9	110
CB125	21.4	11112	36.7	34.8	119	33.4	91.5
CB125N	20.4	15382	44.2	37.9	152	45.9	110
H12	21.6	14097	41.1	36.5	148	44.7	107
H12a	19.4	15417	45.3	38.2	155	44.8	106
H12c	17.8	13359	44.0	40.7	127	31.9	90.1
H12	18.7	13144	42.7	36.2	139	42.3	101
H12	18.7	13140	42.7	36.2	139	42.3	101
12WF	17.6	14375	45.9	37.5	143	43.6	104
CB125N	17.7	14375	45.9	37.5	143	43.5	104
H12	18.7	13140	42.7	36.2	139	42.3	101
CB125	16.6	10459	40.3	34.1	115	33.4	87.1
H12	16.0	12215	44.5	35.9	131	40.0	95.3
H12	16.0	12215	44.5	35.9	131	40.0	95.3
CB125N	15.1	13361	47.9	37.2	134	41.0	98.0
H12	15.0	13361	47.9	37.2	134	41.1	97.9
H12	16.0	12215	44.5	35.9	131	40.0	95.3
12WF	12.9	12453	49.9	37.0	126	38.6	92.4
CB125	13.3	9835	43.7	33.4	110	33.4	82.6
CB125N	13.0	12445	49.9	37.0	126	38.6	92.4
H12	13.6	11321	46.4	35.5	122	37.7	89.6
H12	13.6	11318	46.4	35.5	122	37.7	89.6
H12	13.6	11318	46.4	35.5	122	37.7	89.6
H12	13.6	11318	46.4	35.5	122	37.7	89.6
H12	11.6	10485	48.5	35.3	114	35.4	84.2
H12	10.9	11532	52.3	36.7	118	36.3	86.6
CB125N	10.9	11528	52.3	36.7	118	36.3	86.7
H12	11.6	10481	48.5	35.3	114	35.4	84.2
H12	12.0	18988	64.1	47.5	154	47.7	118
H12	11.6	10481	48.5	35.3	114	35.4	84.2
CB125	11.2	9247	46.2	32.8	106	33.4	78.2
H12	9.65	9648	50.9	35.0	106	33.1	78.6
12WF	9.10	10642	55.0	36.4	110	34.0	80.9
CB125N	9.12	10635	55.0	36.4	110	34.0	81.0
H12	9.65	9644	50.9	35.0	106	33.1	78.6
H12	9.65	9644	50.9	35.0	106	33.1	78.6

Table 2.3.2 Torsion Properties -- Steel Sections 1887-1952

Designation	Torsional Constant	Warping Constant	$(EC_w/GJ)^{1/2}$	Normalized Warping Constant	Warping Statical Moment	Statical Moment	Statical Moment
	J	C _w	a	W _{no}	S _w	Q _f	Q _w
	in.4	in.6	in.	in.2	in.4	in.3	in.3
H12	9.65	9644	50.9	35.0	106	33.1	78.6
CB124C	7.93	8172	51.7	35.0	87.4	25.9	68.7
CB124	9.96	5225	36.8	29.6	65.3	22.0	64.2
H12	7.97	8840	53.6	34.7	98.4	30.9	73.1
H12	7.97	8833	53.6	34.7	98.4	30.9	73.1
CB125N	7.47	9735	58.1	36.1	101	31.6	75.1
12WF	7.43	9732	58.2	36.0	101	31.6	75.0
H12	7.97	8833	53.6	34.7	98.4	30.9	73.1
H12	7.97	8833	53.6	34.7	98.4	30.9	73.1
CB124C	6.32	7831	56.6	34.5	85.0	25.9	65.6
H12	6.50	8061	56.7	34.4	90.8	28.7	67.7
H12	6.50	8061	56.7	34.4	90.8	28.7	67.7
12WF	6.01	8871	61.8	35.7	93.0	29.2	69.3
CB125N	6.03	8867	61.7	35.7	93.0	29.2	69.4
H12	6.50	8061	56.7	34.4	90.8	28.7	67.7
CB124	7.19	4863	41.8	29.0	62.6	22.0	60.2
CB124C	5.17	7501	61.3	34.0	82.6	25.9	62.5
H12	5.22	7310	60.2	34.1	83.3	26.5	62.4
H12	5.22	7310	60.2	34.1	83.3	26.5	62.4
CB125N	4.82	8065	65.8	35.4	85.3	27.0	63.8
12WF	4.80	8065	65.9	35.4	85.3	27.0	63.7
H12	5.22	7310	60.2	34.1	83.3	26.5	62.4
H12	5.22	7310	60.2	34.1	83.3	26.5	62.4
CB124	5.55	4585	46.3	28.5	60.2	22.0	56.7
CB124C	4.62	7228	63.7	33.6	80.6	25.9	59.9
H12	4.13	6588	64.3	33.8	75.9	24.3	57.1
CB125N	3.87	7335	70.0	35.2	78.2	24.9	58.8
12WF	3.85	7335	70.2	35.2	78.2	24.9	58.8
H12	4.13	6584	64.3	33.8	75.9	24.3	57.1
H12	4.13	6584	64.3	33.8	75.9	24.3	57.1
CB124B	3.25	6083	69.6	34.9	65.2	20.1	52.2
CB124	4.51	4320	49.8	27.9	57.9	22.0	53.1
H12s	3.91	5175	58.6	31.0	64.7	22.4	53.3
H12	3.20	5889	69.0	33.5	68.8	22.2	51.9
H12	3.20	5889	69.0	33.5	68.8	22.2	51.9
CB125N	2.96	6546	75.7	34.9	70.4	22.5	53.3
12WF	2.94	6546	75.9	34.9	70.4	22.6	53.2
H12	3.20	5889	69.0	33.5	68.8	22.2	51.9
H12/10	3.68	4021	53.2	28.4	54.6	20.6	49.7
CB124B	2.56	5863	76.9	34.5	63.6	20.1	49.6
H12/10	3.68	4021	53.2	28.4	54.6	20.6	49.7
H12s	3.03	4627	62.9	30.8	58.5	20.4	48.5
CB123B	3.55	3257	48.7	26.0	46.9	19.7	47.7

Table 2.3.2 Torsion Properties -- Steel Sections 1887-1952

Designation	Torsional Constant	Warping Constant	$(EC_w/GJ)_{1/2}$	Normalized Warping Constant	Warping Statical Moment	Statical Moment	Statical Moment
	J	C _w	a	W _{no}	S _w	Q _f	Q _w
	in.4	in.6	in.	in.2	in.4	in.3	in.3
H12	2.43	5217	74.6	33.2	61.7	20.0	46.8
H12	2.43	5217	74.6	33.2	61.7	20.0	46.8
CB124B	2.19	5684	82.0	34.2	62.3	20.1	47.4
12WF	2.19	5787	82.7	34.5	62.8	20.3	47.7
CB125N	2.20	5787	82.5	34.5	62.8	20.2	47.7
H12	2.43	5217	74.6	33.2	61.7	20.0	46.8
H12/10	2.86	3595	57.0	28.2	49.5	18.8	45.2
H12a	2.77	4016	61.3	29.2	51.5	19.7	47.0
12WF	2.76	4009	61.3	29.2	51.5	19.6	47.0
CB124N	2.77	4009	61.2	29.2	51.5	19.6	47.0
H12/10	2.86	3595	57.0	28.2	49.5	18.8	45.2
H12s	2.88	3555	56.5	28.1	49.1	18.7	45.2
CB123B	2.70	2889	52.6	25.7	42.1	17.8	43.1
H12/10	2.18	3188	61.5	27.9	44.4	17.0	40.8
H12a	2.11	3585	66.3	28.9	46.5	17.9	42.4
12WF	2.11	3581	66.4	28.9	46.4	17.9	42.4
CB124N	2.11	3581	66.2	28.9	46.4	17.9	42.5
H12/10	2.18	3188	61.5	27.9	44.4	17.0	40.8
H12s	2.20	3150	60.9	27.8	44.1	16.9	40.8
H12s	2.06	2355	54.4	25.1	36.3	15.3	37.6
H12/8	2.47	1918	44.8	22.7	32.5	15.2	37.9
CB123B	2.11	2599	56.5	25.5	38.2	16.3	39.3
H12/8	2.47	1918	44.8	22.7	32.5	15.2	37.9
12WF	1.59	3168	71.9	28.7	41.3	16.0	38.2
CB124N	1.59	3168	71.7	28.7	41.3	16.0	38.3
H12a	1.58	3168	72.1	28.7	41.3	16.0	38.1
H12/10	1.62	2795	66.9	27.6	39.5	15.3	36.4
H12/10	1.62	2795	66.9	27.6	39.5	15.3	36.4
H12/8	1.89	1699	48.2	22.4	29.2	13.8	34.3
H12/8	1.89	1699	48.2	22.4	29.2	13.8	34.3
12WF	1.79	1881	52.2	23.3	30.2	14.3	35.4
H12b	1.79	1877	52.1	23.3	30.2	14.3	35.4
CB123	1.80	1935	52.8	23.4	30.9	14.6	36.1
CB123N	1.80	1881	52.0	23.3	30.2	14.3	35.5
H12s	1.53	2063	59.0	24.9	32.3	13.8	33.6
H12/8	1.41	1491	52.4	22.2	25.9	12.3	30.6
H12/8	1.41	1488	52.3	22.2	25.9	12.3	30.6
12WF	1.32	1649	56.8	23.1	26.7	12.7	31.6
H12b	1.32	1649	56.9	23.1	26.7	12.7	31.6
H12s	1.45	1491	51.7	22.2	25.9	12.3	30.9
CB123	1.33	1704	57.6	23.2	27.5	13.1	32.3
CB123N	1.33	1649	56.7	23.1	26.7	12.7	31.7
H12/8	1.02	1290	57.2	22.0	22.8	11.0	27.1
H12/8	1.02	1290	57.2	22.0	22.8	11.0	27.1

Table 2.3.2 Torsion Properties -- Steel Sections 1887-1952

Designation	Torsional Constant	Warping Constant	$(EC_w/GJ)^{1/2}$	Normalized Warping Constant	Warping Statical Moment	Statical Moment	Statical Moment
	J	C _w	a	W _{no}	S _w	Q _f	Q _w
	in.4	in.6	in.	in.2	in.4	in.3	in.3
H12b	0.96	1439	62.4	22.8	23.6	11.4	28.0
12WF	0.96	1439	62.4	22.8	23.6	11.4	28.0
CB123	0.95	1478	63.5	22.9	24.1	11.6	28.5
H12s	1.05	1290	56.4	22.0	22.8	10.9	27.3
CB123N	0.96	1439	62.2	22.8	23.6	11.4	28.0
H11a	44.2	16580	31.2	34.9	181	53.6	130
H11a	39.4	15621	32.0	34.5	172	51.4	124
H11a	35.0	14697	33.0	34.2	163	49.1	118
H11a	31.0	13802	34.0	33.9	155	46.9	112
H11a	27.2	12938	35.1	33.6	147	44.7	107
H11a	23.8	12102	36.3	33.3	139	42.5	101
H11a	20.7	11294	37.6	33.0	131	40.3	96.0
H11a	17.9	10515	39.0	32.7	123	38.2	90.7
H11a	15.3	9754	40.6	32.4	115	36.0	85.4
H11	14.6	8204	38.1	30.6	103	33.9	81.2
H11	12.5	7592	39.7	30.3	96.0	32.0	76.3
H11	10.6	7022	41.5	30.0	89.7	30.0	71.6
H11	8.82	6452	43.5	29.8	83.3	28.1	66.8
H11	7.28	5902	45.8	29.5	77.1	26.2	62.1
H11	5.93	5372	48.4	29.2	71.0	24.3	57.5
H11	4.76	4864	51.4	28.9	65.1	22.4	52.9
H11	3.65	4383	55.7	28.7	58.6	20.3	47.9
H11	2.91	3908	58.9	28.4	53.6	18.7	44.0
H11s	2.97	2991	51.1	28.4	54.2	18.9	44.3
H11s	2.10	2655	57.2	25.6	40.3	15.5	36.9
H11s	1.96	1985	51.1	23.1	33.2	14.0	34.0
H11s	1.45	1735	55.6	22.9	29.5	12.6	30.4
H11s	1.35	1252	48.9	20.4	23.7	11.3	27.7
H11s	0.97	1084	53.6	20.2	20.8	10.0	24.5
H10/12	96.1	31791	29.3	39.7	304	76.6	179
H10/12	87.9	30249	29.8	39.3	292	74.0	172
H10/12	80.0	28770	30.5	39.0	280	71.2	166
H10/12	72.3	27272	31.3	38.7	268	68.5	159
H10/12	65.8	25919	31.9	38.4	257	65.9	153
H10/12	59.7	24608	32.7	38.1	246	63.4	147
H10/12	53.4	23234	33.6	37.8	235	60.8	141
H10/12	47.6	21906	34.5	37.4	223	58.2	134
H10/12	42.7	20708	35.4	37.1	213	55.7	128
H10/12	38.0	19503	36.4	36.8	203	53.3	122
H10/12	33.5	18334	37.6	36.5	192	50.8	117
H10/12	29.4	17195	38.9	36.2	182	48.3	111
H10a	36.1	10427	27.4	29.4	135	43.3	105
H10/12	25.8	16102	40.2	35.9	172	45.9	105

Table 2.3.2 Torsion Properties -- Steel Sections 1887-1952

Designation	Torsional Constant	Warping Constant		Normalized Warping Constant	Warping Statical Moment	Statical Moment	Statical Moment
	J	Cw	(ECw/GJ) ^{1/2} = a	Wno	Sw	Qf	Qw
	in.4	in.6	in.	in.2	in.4	in.3	in.3
H10a	32.1	9790	28.1	29.1	128	41.4	100
H10/12	22.5	15049	41.6	35.6	163	43.6	99.5
H10a	28.3	9181	29.0	28.8	121	39.5	95.2
H10/12	19.3	14014	43.3	35.3	153	41.2	93.9
CB105	27.4	7898	27.3	29.6	99.1	26.0	74.2
H10	26.9	7617	27.1	27.0	107	36.9	90.1
H10	26.9	7614	27.1	27.0	107	36.9	90.1
10WF	26.1	7973	28.1	27.4	109	37.6	91.3
CB103N	26.3	7973	28.0	27.4	109	37.6	91.3
H10a	24.9	8588	29.9	28.5	115	37.6	90.5
H10/12	16.4	12984	45.2	35.0	143	38.8	88.2
CB105	21.4	7458	30.0	29.1	95.5	26.0	71.3
H10	23.6	7122	27.9	26.8	101	35.2	85.6
H10	22.9	7456	29.0	27.2	103	35.7	86.6
CB103N	23.1	7456	28.9	27.2	103	35.7	86.6
H10	23.6	7122	27.9	26.8	101	35.2	85.6
H10a	21.8	8020	30.9	28.3	108	35.8	85.8
H10/12	14.0	12032	47.2	34.6	134	36.5	82.9
H10	20.7	6648	28.9	26.5	95.4	33.4	81.1
10WF	20.0	6958	30.0	26.9	96.7	33.9	82.0
CB105	16.8	7042	33.0	28.5	92.1	26.0	68.4
CB103N	20.1	6958	29.9	26.9	96.7	33.9	82.0
H10	20.7	6646	28.9	26.5	95.4	33.4	81.1
H10	20.7	6646	28.9	26.5	95.4	33.4	81.1
H10a	18.9	7472	32.0	28.0	102	33.9	81.1
H10	18.0	6189	29.9	26.2	89.8	31.7	76.7
CB103N	17.5	6492	31.0	26.7	91.2	32.2	77.6
H10	17.4	6490	31.1	26.7	91.2	32.2	77.6
H10	18.0	6187	29.9	26.2	89.8	31.7	76.7
H10	18.0	6187	29.9	26.2	89.8	31.7	76.7
H10a	16.3	6945	33.2	27.7	95.7	32.1	76.6
CB105	13.3	6647	36.0	28.0	88.7	26.0	65.4
H10/12	12.6	8166	40.9	30.3	104	32.0	73.8
H10	15.5	5748	31.0	26.0	84.3	30.0	72.4
CB103N	15.1	6041	32.1	26.4	85.7	30.5	73.3
10WF	15.0	6041	32.3	26.4	85.7	30.5	73.3
H10	15.5	5748	31.0	26.0	84.3	30.0	72.4
H10	15.5	5748	31.0	26.0	84.3	30.0	72.4
H10a	14.0	6435	34.5	27.4	89.7	30.3	72.1
CB105	10.9	6269	38.6	27.5	85.4	26.0	62.5
H10/12	10.7	7558	42.7	30.0	96.8	30.1	69.3
H10	13.3	5325	32.2	25.7	79.0	28.4	68.2
H10	13.3	5323	32.2	25.7	79.0	28.4	68.2
H10	12.8	5594	33.6	26.1	80.2	28.8	68.9

Table 2.3.2 Torsion Properties -- Steel Sections 1887-1952

Designation	Torsional Constant	Warping Constant	$(EC_w/GJ)1/2=$	Normalized Warping Constant	Warping Statical Moment	Statical Moment	Statical Moment
	J	C _w	a	W _{no}	S _w	Q _f	Q _w
	in.4	in.6	in.	in.2	in.4	in.3	in.3
CB103N	12.9	5594	33.5	26.1	80.2	28.8	68.9
H10	13.3	5323	32.2	25.7	79.0	28.4	68.2
H10a	11.9	5947	36.0	27.2	83.7	28.5	67.6
H10	11.3	4917	33.6	25.5	73.8	26.7	64.0
H10	11.3	4917	33.6	25.5	73.8	26.7	64.0
H10/12	8.9	6942	44.9	29.8	89.9	28.0	64.6
10WF	10.8	5167	35.1	25.9	74.8	27.0	64.6
CB103N	10.9	5167	35.0	25.9	74.8	27.0	64.6
CB105	9.3	5908	40.5	27.0	82.1	26.0	59.5
H10	11.30	4917	33.6	25.5	73.8	26.7	64.0
H10	11.30	4917	33.6	25.5	73.8	26.7	64.0
CB103N	9.37	4799	36.4	25.7	70.0	25.4	60.8
H10	9.27	4796	36.6	25.7	70.0	25.4	60.8
H10	9.59	4540	35.0	25.2	68.9	25.0	60.0
H10	9.59	4540	35.0	25.2	68.9	25.0	60.0
H10	9.59	4540	35.0	25.2	68.9	25.0	60.0
H10	9.59	4540	35.0	25.2	68.9	25.0	60.0
H10/12	7.34	6344	47.3	29.5	83.1	26.0	60.0
CB104	9.08	3447	31.3	24.5	52.4	17.6	49.6
H10	8.00	4164	36.7	25.0	63.9	23.4	55.9
10WF	7.74	4409	38.4	25.4	65.1	23.8	56.7
CB103N	7.82	4409	38.2	25.4	65.1	23.8	56.7
H10	8.00	4161	36.7	25.0	63.9	23.4	55.9
H10	8.00	4161	36.7	25.0	63.9	23.4	55.9
H10	8.00	4161	36.7	25.0	63.9	23.4	55.9
H10/12	6.04	5797	49.9	29.2	76.8	24.2	55.7
CB104	6.50	3213	35.8	23.9	50.1	17.6	46.7
H10	6.60	3801	38.6	24.7	59.1	21.8	52.0
H10	6.60	3801	38.6	24.7	59.1	21.8	52.0
H10	6.33	4021	40.6	25.1	60.0	22.1	52.5
CB103N	6.40	4021	40.3	25.1	60.0	22.1	52.5
H10	6.60	3801	38.6	24.7	59.1	21.8	52.0
H10	6.60	3801	38.6	24.7	59.1	21.8	52.0
H10/12	4.87	5257	52.9	28.9	70.5	22.4	51.3
H10	5.37	3453	40.8	24.4	54.3	20.2	48.0
H10	5.37	3453	40.8	24.4	54.3	20.2	48.0
10WF	5.11	3647	43.0	24.9	55.0	20.4	48.4
CB103N	5.16	3647	42.8	24.9	55.0	20.4	48.4
CB104	5.00	3020	39.5	23.5	48.2	17.6	44.1
H10	5.37	3453	40.8	24.4	54.3	20.2	48.0
H10	5.37	3453	40.8	24.4	54.3	20.2	48.0
H10/12	3.80	4710	56.7	28.7	64.0	20.4	46.8
10WF	4.17	3330	45.5	24.6	50.6	18.9	44.9

Table 2.3.2 Torsion Properties -- Steel Sections 1887-1952

Designation	Torsional Constant	Warping Constant	$(EC_w/GJ)1/2=$	Normalized Warping Constant	Warping Statical Moment	Statical Moment	Statical Moment
	J	C _w	a	W _{no}	S _w	Q _f	Q _w
	in.4	in.6	in.	in.2	in.4	in.3	in.3
CB103N	4.22	3330	45.2	24.6	50.6	18.9	44.9
H10	4.31	3120	43.3	24.2	49.7	18.7	44.2
H10	4.31	3120	43.3	24.2	49.7	18.7	44.2
H10	4.31	3120	43.3	24.2	49.7	18.7	44.2
H10	4.31	3120	43.3	24.2	49.7	18.7	44.2
CB104	4.06	2839	42.5	23.0	46.3	17.6	41.5
H10/12	2.92	4193	61.0	28.4	57.7	18.5	42.4
H10	3.28	2999	48.7	24.4	46.1	17.4	41.0
H10	3.40	2802	46.2	23.9	45.2	17.1	40.4
CB103N	3.32	2999	48.4	24.4	46.1	17.4	41.0
10WF	3.27	2997	48.7	24.4	46.1	17.4	41.0
H10	3.40	2802	46.2	23.9	45.2	17.1	40.4
H10	3.40	2802	46.2	23.9	45.2	17.1	40.4
H10	3.40	2802	46.2	23.9	45.2	17.1	40.4
CB103A	2.96	2369	45.5	24.6	35.9	12.7	35.3
CB103	3.17	1878	39.1	22.1	31.7	12.4	34.5
H10/12	2.22	3715	65.8	28.1	51.9	16.8	38.3
H10	2.63	2498	49.6	23.7	40.9	15.6	36.7
H10	2.63	2498	49.6	23.7	40.9	15.6	36.7
10WF	2.49	2666	52.6	24.1	41.5	15.8	37.0
CB103N	2.53	2666	52.2	24.1	41.5	15.8	37.0
H10	2.63	2498	49.6	23.7	40.9	15.6	36.7
H10	2.63	2498	49.6	23.7	40.9	15.6	36.7
CB103A	2.20	2267	51.7	24.3	34.9	12.7	33.5
CB103	2.16	1752	45.8	21.6	30.3	12.4	32.0
H10	1.99	2206	53.6	23.4	36.6	14.1	33.0
H10	1.99	2206	53.6	23.4	36.6	14.1	33.0
H10	1.99	2206	53.6	23.4	36.6	14.1	33.0
H10	1.99	2206	53.6	23.4	36.6	14.1	33.0
H10	1.85	2347	57.4	23.8	36.9	14.2	33.1
CB103N	1.88	2347	56.9	23.8	36.9	14.2	33.1
10WF	1.84	2345	57.4	23.8	36.9	14.2	33.1
CB103A	1.68	2169	57.8	24.0	33.9	12.7	31.6
H10s	1.88	1648	47.7	21.2	30.2	12.8	30.5
H10	1.48	1932	58.2	23.2	32.5	12.6	29.6
H10	1.48	1932	58.2	23.2	32.5	12.6	29.6
CB103	1.61	1636	51.3	21.1	29.0	12.4	29.4
CB103A	1.37	2073	62.6	23.6	32.9	12.7	29.8
10WF	1.38	2073	62.4	23.6	32.9	12.7	29.7
CB103N	1.40	2073	61.8	23.6	32.9	12.7	29.7
H10	1.48	1932	58.2	23.2	32.5	12.6	29.6
H10/8	1.73	1202	42.5	19.0	24.4	11.5	27.8
H10/8	1.73	1202	42.5	19.0	24.4	11.5	27.8
H10s	1.39	1438	51.8	20.9	26.7	11.4	27.2

Table 2.3.2 Torsion Properties -- Steel Sections 1887-1952

Designation	Torsional Constant	Warping Constant	$(EC_w/GJ)_{1/2}$	Normalized Warping Constant	Warping Statical Moment	Statical Moment	Statical Moment
	J	C _w	a	W _{no}	S _w	Q _f	Q _w
	in.4	in.6	in.	in.2	in.4	in.3	in.3
10WF	1.50	1201	45.6	19.1	23.6	11.3	27.0
H10a	1.50	1201	45.6	19.1	23.6	11.3	27.0
CB102N	1.53	1201	45.1	19.1	23.6	11.3	27.0
H10/8	1.27	1049	46.2	18.8	21.7	10.3	24.8
H10/8	1.27	1049	46.2	18.8	21.7	10.3	24.8
CB102	1.20	851	42.8	20.0	15.9	7.0	22.1
H10s	1.29	1038	45.7	18.7	21.5	10.2	24.8
H10a	1.13	1063	49.3	18.9	21.1	10.1	24.3
10WF	1.13	1063	49.4	18.9	21.1	10.1	24.3
CB102N	1.16	1063	48.8	18.9	21.1	10.1	24.3
10WF	0.97	994	51.5	18.8	19.8	9.53	23.0
H10/8	0.91	905	50.7	18.6	19.0	9.09	21.9
H10/8	0.91	905	50.7	18.6	19.0	9.09	21.9
H10s	0.92	894	50.2	18.5	18.8	9.04	21.9
10WF	0.83	929	53.9	18.7	18.6	8.96	21.7
H10a	0.83	926	53.9	18.7	18.6	8.96	21.6
CB102N	0.85	926	53.2	18.7	18.6	8.96	21.6
CB102	0.66	796	55.7	19.6	15.2	7.04	19.9
H10/8	0.63	771	56.1	18.4	16.4	7.92	19.1
H10/8	0.63	771	56.1	18.4	16.4	7.92	19.1
H10a	0.58	792	59.3	18.6	16.0	7.74	19.0
CB102N	0.60	792	58.4	18.6	16.0	7.74	19.0
10WF	0.58	792	59.5	18.6	16.0	7.74	18.9
CB102	0.42	752	67.8	19.2	14.7	7.04	18.1
H9a	29.0	6275	23.7	24.3	97.8	34.3	83.5
H9a	25.7	5869	24.3	24.1	92.5	32.7	79.4
H9a	22.6	5481	25.1	23.8	87.4	31.2	75.3
H9a	19.7	5108	25.9	23.6	82.4	29.6	71.3
H9a	17.1	4747	26.8	23.3	77.5	28.1	67.4
H9a	14.8	4402	27.8	23.1	72.7	26.5	63.6
H9a	12.7	4071	28.9	22.8	68.0	25.0	59.8
H9a	10.7	3753	30.1	22.6	63.5	23.6	56.1
H9a	9.11	3459	31.4	22.4	59.2	22.1	52.5
H9	8.62	2814	29.1	20.8	51.6	20.5	49.4
H9	7.19	2574	30.4	20.6	47.8	19.2	46.1
H9	5.93	2345	32.0	20.4	44.1	17.9	42.7
H9	4.82	2125	33.8	20.1	40.5	16.6	39.5
H9	3.87	1917	35.8	19.9	37.0	15.3	36.3
H9	3.05	1717	38.2	19.7	33.6	14.0	33.1
H9	2.35	1527	41.0	19.4	30.3	12.7	30.1
H9	1.78	1346	44.3	19.2	27.1	11.5	27.0
CB93	1.55	1381	48.0	19.6	26.4	11.1	26.4
H9	1.30	1173	48.3	19.0	24.0	10.3	24.1

Table 2.3.2 Torsion Properties -- Steel Sections 1887-1952

Designation	Torsional Constant	Warping Constant	$(EC_w/GJ)^{1/2}$	Normalized Warping Constant	Warping Statical Moment	Statical Moment	Statical Moment
	J	C _w	a	W _{no}	S _w	Q _f	Q _w
	in.4	in.6	in.	in.2	in.4	in.3	in.3
CB93	1.13	1207	52.6	19.4	23.3	9.90	23.5
H9s	1.22	846	42.3	16.9	19.3	9.19	22.0
CB93	0.79	1039	58.2	19.2	20.3	8.70	20.6
H9s	0.87	727	46.6	16.7	16.9	8.11	19.4
CB92	0.99	495	35.9	14.1	13.1	7.59	18.7
H9s	0.80	502	40.3	14.7	13.2	7.16	17.5
CB92	0.77	441	38.5	14.0	11.8	6.91	17.0
CB92	0.58	391	41.7	13.9	10.6	6.24	15.3
H9s	0.55	426	44.8	14.5	11.4	6.24	15.2
H8a	23.0	3603	20.1	19.8	68.9	26.6	65.0
H8a	20.2	3354	20.7	19.6	65.0	25.3	61.6
H8a	17.7	3119	21.4	19.3	61.2	24.0	58.3
H8a	15.4	2891	22.1	19.1	57.5	22.8	55.1
H8a	13.2	2674	22.9	18.9	53.8	21.5	51.9
H8	12.4	2129	21.1	17.5	46.2	19.8	48.5
H8a	11.3	2466	23.7	18.7	50.3	20.3	48.7
H8	12.4	2129	21.1	17.5	46.2	19.8	48.5
H8	12.4	2129	21.1	17.5	46.2	19.8	48.5
CB83	11.5	2196	22.3	17.9	45.9	19.5	48.3
H8	10.6	1962	21.9	17.3	43.2	18.7	45.5
H8	10.6	1962	21.9	17.3	43.2	18.7	45.5
H8a	9.63	2268	24.7	18.4	46.9	19.1	45.6
H8	10.6	1964	21.9	17.3	43.2	18.7	45.5
CB83	9.44	1985	23.3	17.6	42.1	18.1	44.7
H8	9.02	1803	22.8	17.0	40.2	17.6	42.6
H8	9.04	1802	22.7	17.0	40.2	17.6	42.6
H8a	8.16	2085	25.7	18.2	43.6	17.9	42.7
H8	9.02	1803	22.8	17.0	40.2	17.6	42.6
CB83	7.63	1782	24.6	17.4	38.4	16.7	41.1
H8	7.66	1658	23.7	16.9	37.4	16.5	39.9
H8	7.66	1656	23.7	16.9	37.4	16.5	39.9
H8	7.66	1656	23.7	16.9	37.4	16.5	39.9
H8a	6.79	1904	26.9	18.0	40.4	16.7	39.8
H8	6.38	1512	24.8	16.6	34.6	15.4	37.1
CB83	6.09	1592	26.0	17.1	34.9	15.4	37.6
H8	6.38	1510	24.8	16.6	34.6	15.4	37.1
H8	6.38	1510	24.8	16.6	34.6	15.4	37.1
H8	6.38	1510	24.8	16.6	34.6	15.4	37.1
H8	5.26	1373	26.0	16.4	31.9	14.3	34.4
H8	5.26	1372	26.0	16.4	31.9	14.3	34.4
CB83	5.08	1461	27.3	16.8	32.5	14.6	35.1
8WF	5.05	1441	27.2	16.7	32.3	14.5	34.8
H8	5.05	1441	27.2	16.7	32.3	14.5	34.8
H8	5.26	1372	26.0	16.4	31.9	14.3	34.4

Table 2.3.2 Torsion Properties -- Steel Sections 1887-1952

Designation	Torsional Constant	Warping Constant	(EC_w/GJ) ^{1/2} =	Normalized Warping Constant	Warping Statical Moment	Statical Moment	Statical Moment
	J	C _w	a	W _{no}	S _w	Q _f	Q _w
	in.4	in.6	in.	in.2	in.4	in.3	in.3
H8	5.26	1372	26.0	16.4	31.9	14.3	34.4
CB83	4.74	1411	27.8	16.8	31.4	14.0	34.1
H8	4.28	1240	27.4	16.2	29.2	13.2	31.8
H8	4.28	1240	27.4	16.2	29.2	13.2	31.8
H8	4.28	1240	27.4	16.2	29.2	13.2	31.8
H8	4.28	1240	27.4	16.2	29.2	13.2	31.8
CB83N	4.10	1319	28.9	16.6	29.8	13.6	32.3
H8	4.08	1301	28.7	16.5	29.6	13.5	32.1
CB83	3.61	1239	29.8	16.6	28.0	12.7	30.7
8WF	3.32	1181	30.4	16.3	27.1	12.4	29.6
CB83N	3.33	1195	30.5	16.5	27.2	12.4	29.8
H8	3.43	1115	29.0	16.0	26.7	12.2	29.1
H8	3.43	1115	29.0	16.0	26.7	12.2	29.1
H8	3.43	1115	29.0	16.0	26.7	12.2	29.1
H8	3.43	1115	29.0	16.0	26.7	12.2	29.1
CB83	2.67	1076	32.3	16.3	24.7	11.3	27.3
H8	2.70	997	30.9	15.8	24.2	11.2	26.6
H8	2.57	1050	32.5	16.1	24.4	11.3	26.9
CB83N	2.54	1062	32.9	16.2	24.5	11.3	27.0
H8	2.70	996	30.9	15.8	24.2	11.2	26.6
H8	2.70	996	30.9	15.8	24.2	11.2	26.6
H8	2.08	884	33.1	15.6	21.8	10.2	24.1
H8	2.08	884	33.1	15.6	21.8	10.2	24.1
H8	2.08	884	33.1	15.6	21.8	10.2	24.1
H8	2.08	884	33.1	15.6	21.8	10.2	24.1
8WF	1.96	930	35.1	15.9	22.0	10.3	24.2
H8	1.96	930	35.1	15.9	22.0	10.3	24.2
CB83N	1.97	943	35.2	16.0	22.1	10.3	24.4
CB83	1.90	922	35.4	16.0	21.6	10.0	24.0
H8	1.57	776	35.8	15.4	19.4	9.16	21.6
H8	1.51	827	37.7	15.7	19.8	9.31	22.0
CB83N	1.52	838	37.8	15.8	19.9	9.36	22.1
H8	1.57	776	35.8	15.4	19.4	9.16	21.6
H8	1.57	776	35.8	15.4	19.4	9.16	21.6
H8	1.57	776	35.8	15.4	19.4	9.16	21.6
CB183	1.30	778	39.4	15.8	18.5	8.70	20.8
8WF	1.12	725	40.9	15.5	17.5	8.28	19.7
H8	1.12	725	41.0	15.5	17.5	8.27	19.7
CB83N	1.13	734	41.0	15.7	17.6	8.31	19.8
H8	1.15	675	39.0	15.2	17.2	8.18	19.2
H8	1.15	675	39.0	15.2	17.2	8.18	19.2
H8	1.15	675	39.0	15.2	17.2	8.18	19.2
H8	1.15	675	39.0	15.2	17.2	8.18	19.2

Table 2.3.2 Torsion Properties -- Steel Sections 1887-1952

Designation	Torsional Constant	Warping Constant	$(EC_w/GJ)^{1/2}$	Normalized Warping Constant	Warping Statical Moment	Statical Moment	Statical Moment
	J	C _w	a	W _{no}	S _w	Q _f	Q _w
	in.4	in.6	in.	in.2	in.4	in.3	in.3
H4	0.97	525	37.5	15.3	14.3	6.60	17.2
CB83N	0.83	643	44.7	15.5	15.5	7.41	17.6
8WF	0.77	618	45.6	15.3	15.1	7.25	17.1
H8	0.77	618	45.6	15.3	15.1	7.25	17.1
H8	0.81	578	42.9	15.0	15.0	7.21	16.9
CB83N	0.78	626	45.6	15.4	15.2	7.28	17.2
H8	0.81	578	42.9	15.0	15.0	7.21	16.9
H8	0.81	578	42.9	15.0	15.0	7.21	16.9
H8	0.81	578	42.9	15.0	15.0	7.21	16.9
H8/6.5	1.00	380	31.4	12.5	11.7	6.72	16.3
H8/6.5	1.00	380	31.4	12.5	11.7	6.72	16.3
H	0.70	499	43.1	15.1	13.8	6.56	16.1
H4	0.68	499	43.5	15.1	13.8	6.60	16.2
H4	0.75	499	41.5	15.1	13.8	6.60	16.2
H4	0.75	498	41.4	15.1	13.8	6.60	16.2
8WF	0.64	573	48.0	15.2	14.1	6.78	16.0
CB83N	0.65	581	47.9	15.3	14.2	6.82	16.1
H8	0.64	573	48.0	15.2	14.1	6.78	16.0
8x8	0.63	487	44.9	15.0	13.5	6.56	15.6
H4	0.68	486	43.1	15.0	13.6	6.60	15.7
H8	0.58	495	46.8	14.9	13.0	6.26	14.9
H8	0.58	495	46.8	14.9	13.0	6.26	14.9
H8s	0.75	400	37.1	13.2	11.7	6.35	15.3
H8	0.58	495	46.8	14.9	13.0	6.26	14.9
H8	0.54	530	50.6	15.1	13.1	6.32	15.0
8WF	0.53	530	50.7	15.1	13.1	6.32	14.9
CB83N	0.54	534	50.6	15.3	13.1	6.32	15.0
H8/6.5	0.71	326	34.5	12.3	10.2	5.94	14.4
H8/6.5	0.71	326	34.5	12.3	10.2	5.94	14.4
H8a	0.65	339	36.8	12.5	10.1	5.88	14.3
CB82N	0.67	347	36.6	12.6	10.3	6.00	14.5
8WF	0.53	312	38.9	12.4	9.40	5.50	13.3
H8s	0.51	337	41.2	13.0	10.1	5.53	13.2
H8a	0.48	300	40.1	12.4	9.07	5.32	12.8
CB82N	0.49	304	39.9	12.5	9.15	5.38	12.9
8WF	0.48	299	40.1	12.4	9.05	5.31	12.8
H8/6.5	0.49	276	38.2	12.1	8.80	5.16	12.5
H8/6.5	0.49	276	38.2	12.1	8.80	5.16	12.5
H8a	0.35	263	44.0	12.2	8.02	4.75	11.4
CB82N	0.36	264	43.9	12.4	8.03	4.76	11.4
8WF	0.34	258	44.1	12.2	7.92	4.69	11.3
H8/6.5	0.32	228	42.7	12.0	7.43	4.40	10.7
H8/6.5	0.32	228	42.7	12.0	7.43	4.40	10.7
H8x6.5	0.48	252	37.0	12.6	8.26	4.73	12.3

Table 2.3.2 Torsion Properties -- Steel Sections 1887-1952

Designation	Torsional Constant	Warping Constant	(EC_w/GJ) ^{1/2} =	Normalized Warping Constant	Warping Statical Moment	Statical Moment	Statical Moment
	J	C _w	a	W _{no}	S _w	Q _f	Q _w
	in.4	in.6	in.	in.2	in.4	in.3	in.3
H8x6.5	0.38	239	40.6	12.4	7.99	4.73	11.4
H6a	8.93	1821	23.0	16.3	41.9	14.6	35.6
H6/10	9.12	1792	22.6	16.3	42.0	14.6	35.7
CB61N	10.06	1479	19.5	14.6	37.9	13.5	33.1
H6/10	6.94	1552	24.1	16.0	37.3	13.2	32.1
H6a	6.78	1581	24.6	15.9	37.2	13.1	31.9
CB61N	7.67	1278	20.8	14.2	33.6	12.2	29.7
H6/10	5.33	1356	25.7	15.6	33.1	11.9	28.8
H6a	5.20	1383	26.2	15.6	33.2	11.9	28.7
CB61N	5.24	1047	22.7	13.8	28.4	10.6	25.4
H6/10	4.17	1199	27.3	15.4	30.0	10.9	26.3
H6a	4.06	1224	27.9	15.3	29.9	10.8	26.1
H6a	2.96	1052	30.3	15.0	26.2	9.66	23.1
H6/10	3.04	1026	29.6	15.1	26.3	9.70	23.2
CB61N	3.38	838	25.4	13.4	23.6	8.97	21.4
H6/10	2.13	864	32.4	14.8	22.7	8.51	20.3
H6a	2.04	884	33.5	14.7	22.5	8.43	20.0
CB61N	2.00	652	29.1	12.9	18.9	7.36	17.4
H6a	1.37	739	37.4	14.4	19.2	7.30	17.3
H6/10	1.41	712	36.1	14.5	19.2	7.33	17.3
B6	2.02	275	18.8	9.37	11.0	6.47	15.8
H6	1.98	272	18.9	9.34	10.9	6.47	15.6
H6	2.01	266	18.5	9.33	10.9	6.47	15.6
H6	2.01	266	18.5	9.33	10.9	6.47	15.6
CB61N	1.05	484	34.5	12.5	14.5	5.80	13.6
H6a	0.90	613	42.0	14.1	16.3	6.26	14.7
H6/10	0.93	588	40.5	14.2	16.3	6.29	14.8
H6	1.55	234	19.8	9.17	9.74	5.87	14.1
H6	1.55	234	19.8	9.17	9.74	5.87	14.1
H6	1.16	204	21.3	9.02	8.65	5.28	12.6
H6	1.16	204	21.3	9.02	8.65	5.28	12.6
H6	0.84	181	23.6	8.87	7.64	4.72	11.2
H6	0.85	176	23.1	8.86	7.60	4.70	11.2
H6	0.85	176	23.1	8.86	7.60	4.70	11.2
6WF	0.62	170	26.5	9.11	6.96	4.29	10.4
CBS6	0.61	169	26.7	9.11	6.96	4.29	10.4
6WF	0.65	160	25.3	8.77	6.86	4.26	10.2
6H	0.71	122	21.1	8.37	6.09	3.73	9.43
H3a	0.71	122	21.1	8.37	6.09	3.73	9.43
H6	0.60	155	25.8	8.75	6.65	4.13	9.90
H3	0.63	121	22.4	8.50	5.9	3.6	9.1
H6	0.59	154	26.0	8.72	6.6	4.1	9.8
H6	0.60	150	25.5	8.71	6.60	4.13	9.78

Table 2.3.2 Torsion Properties -- Steel Sections 1887-1952

Designation	Torsional Constant	Warping Constant	$(EC_w/GJ)^{1/2}$	Normalized Warping Constant	Warping Statical Moment	Statical Moment	Statical Moment
	J	C _w	a	W _{no}	S _w	Q _f	Q _w
	in.4	in.6	in.	in.2	in.4	in.3	in.3
H6	0.60	150	25.5	8.71	6.60	4.13	9.78
6WF	0.47	150	28.6	8.99	6.23	3.88	9.39
CBS6	0.46	150	28.9	8.99	6.23	3.88	9.39
6WF	0.49	142	27.3	8.65	6.16	3.87	9.18
6x6	0.52	113	23.7	8.19	5.85	3.73	8.87
H3a	0.58	113	22.6	8.19	5.84	3.73	8.87
H3	0.50	113	24.3	8.32	5.63	3.56	8.52
H3	0.50	113	24.3	8.32	5.63	3.56	8.52
H6	0.39	128	29.3	8.56	5.61	3.55	8.40
H6	0.40	125	28.3	8.56	5.64	3.58	8.42
H6	0.40	125	28.3	8.56	5.64	3.58	8.42
H3	0.45	109	25.0	8.24	5.52	3.56	8.24
6WF	0.35	131	31.2	8.88	5.52	3.47	8.38
6H	0.39	96.3	25.2	8.52	4.90	3.03	7.75
CBS6	0.34	131	31.5	8.88	5.52	3.47	8.38
H3	0.39	96.3	25.2	8.52	4.90	3.03	7.75
6WF	0.36	125	29.8	8.54	5.46	3.47	8.19
6WF	0.25	113	34.3	8.78	4.85	3.08	7.40
H6	0.26	107	32.8	8.44	4.75	3.03	7.19
H6	0.26	103	31.7	8.44	4.75	3.03	7.19
CBS6	0.24	113	34.7	8.78	4.85	3.08	7.40
6H	0.26	90	29.7	8.34	4.71	3.04	7.20
H3	0.30	90	27.9	8.34	4.70	3.03	7.19
H6	0.26	103	31.7	8.44	4.75	3.03	7.19
6WF	0.18	98.0	37.6	8.70	4.21	2.68	6.53
6WF	0.18	91.9	36.0	8.37	4.11	2.63	6.33
CBS6	0.18	97.2	37.5	8.70	4.21	2.68	6.53
CBS	0.17	91.7	37.3	8.70	4.11	2.61	6.45
6WF	0.12	79.6	42.0	8.60	3.47	2.22	5.52
CBS6	0.11	79.6	42.7	8.60	3.47	2.22	5.52
CBS	0.11	75.5	41.6	8.60	3.47	2.22	5.52
6WF	0.12	73.9	40.5	8.27	3.34	2.14	5.29

References

Table 2.3.3 Producers -- Steel Sections 1887-1952

From Iron and Steel Beams 1873 to 1952, pages 12 - 126, AISC.

The letters preceding the date designate the company that issued the catalog, as follows:

B	Bethlehem Steel Company
C	The Carnegie Steel Company, Limited 1893 to 1896
C	Carnegie Steel Company 1900 to 1934
C A	Cambria Steel Company
CAM	Cambria Steel Company
C B	Carnegie Brothers & Co., Limited
CIL	Carnegie - Illinois Steel Corporation
C K	Carnegie, Kloman & Co., Union Iron Mills
C P	Carnegie, Phipps & Co., Limited
I L	Illinois Steel Company
I N	Inland Steel Company
J & L	Jones & Laughlins Limited 1893 to 1902
J & L	Jones & Laughlin Steel Company, Beginning 1903
J & L	Jones & Laughlin Steel Corporation, Beginning 1926
K	Kaiser Steel Corporation
L A	Lackawanna Steel Company
N J	New Jersey Steel & Iron Co.
P A	The Passaic Rolling Mill Co.
P E	A. & P. Roberts Company (Pencoyd Iron Works)
P H	The Phoenix Iron Company
P O	Pottsville Iron & Steel Co.
S	Bethlehem Steel Company, Beginning 1909
U S	United States Steel Company

2.3.3a Producers - American Standard Beams

Depth	24		20		18		15		12		10		9		8		7		6		5		4		3-1/2 and 3			
Ref.	Mill	Year	Mill	Year	Mill	Year	Mill	Year	Mill	Year	Mill	Year	Mill	Year	Mill	Year	Mill	Year	Mill	Year	Mill	Year	Mill	Year	Mill	Year	Mill	Year
1	B	1907	CPI 1889 CPI 1890	1889 1890	C	1896	CP 1889 CP 1890 CP 1892	1889 1890 1892	CP 1889 CP 1890	1889 1890	CP 1889 CP 1890	1889 1890	CP 1889 CP 1890	1889 1890	CP 1889 CP 1890	1889 1890	CP 1889 CP 1890	1889 1890	CP 1889 CP 1890	1889 1890	CP 1889 CP 1890	1889 1890	CP 1889 CP 1890	1889 1890	C	1893		
2	S13 S19 S30 S43 S47 S51 S53	1922 1926 1929 1933 1934 1938 1943	CP 1892 C 1893	1892 1893	C	1913	CP 1892	1892	CP 1892	1892	CP 1892	1892	CP 1892	1892	CP 1892	1892	CP 1892	1892	CP 1892	1892	C	1892	C	1892	C	1896 TO 1920 INC.		
3	S13 S19 S30 S43 S47 S51 S53 S54 S56	1922 1926 1929 1933 1934 1938 1943 1946 1948	C 1896 C 1903 C 1913 IL 1914 C 1915 C 1916 C 1917 C 1919 C 1920	1896 1903 1913 1914 1915 1916 1917 1919 1920	C	1916	C 1893	1893	C 1893	1893	CP 1893	C 1893	C 1893	C 1893	C 1893	C 1893	C 1893	C 1893	C 1893	C 1893	C	1893	C	1893	C	1921 TO 1940 INC.		
4	S19 S30 S43 S47 S51 S53	1926 1929 1933 1934 1938 1943	C 1921 C 1923 IL 1925 C 1926 C 1930 C 1931 IL 1932 C 1934 IL 1934 CIL 1940	1921 1923 1925 1926 1930 1931 1932 1934 1934 1940	C	1921	C 1896 C 1900 C 1903 C 1913 IL 1914 C 1915 C 1916 C 1917 C 1919 C 1920	1896 1900 1903 1913 1914 1915 1916 1917 1919 1920	C 1896 C 1900 C 1903 C 1913 IL 1914 C 1915 C 1916 C 1917 C 1919 C 1920	1896 1900 1903 1913 1914 1915 1916 1917 1919 1920	C 1896 C 1903 C 1913 IL 1914 C 1915 C 1916 C 1917 C 1919 C 1920	1896 1903 1913 1914 1915 1916 1917 1919 1920	C 1896 TO 1919 INC.	C 1896 TO 1920 INC.	C 1896 TO 1920 INC.	C 1896 TO 1920 INC.	C 1896 TO 1920 INC.	C 1896 TO 1920 INC.	C 1896 TO 1920 INC.	C 1896 TO 1920 INC.	C	1896 TO 1920 INC.	C	1896 TO 1920 INC.	C	1896 TO 1920 INC.	CIL CIL US	1946 1948 1950
5	S19 S30 S43 S47 S51 S53 S54 S56	1926 1929 1933 1934 1938 1943 1946 1948	C 1921 C 1923 IL 1925 C 1926 C 1930 C 1931 C 1932 C 1934 IL 1934 CIL 1940 CIL 1946 CIL 1948 US 1950	1921 1923 1925 1926 1930 1931 1932 1934 1934 1940 1946 1948 1950	C	1913	C 1913 C 1915	1913 1915	C 1913 C 1915	1913 1915	C 1913 C 1915	1913 1915	C 1913 C 1915	C 1913 C 1915	C 1913 C 1915	C 1913 C 1915	C 1913 C 1915	C 1913 C 1915	C 1913 C 1915	C 1913 C 1915	C	1913	CIL 1940 INC.	CIL 1940 INC.	CIL 1940 INC.	CIL 1940 INC.	IL	1914
6	CP C	1892 1893	B 1907	1907	C	1921	C 1916 C 1917 C 1919 C 1920	1916 1917 1919 1920	C 1916 C 1917 C 1919 C 1920	1916 1917 1919 1920	C 1916 C 1917 C 1919 C 1920	1916 1917 1919 1920	B 1907 S6 1919	C 1916 C 1923	CIL 1946 CIL 1948 US 1950	CIL 1946 CIL 1948 US 1950	CIL 1946 CIL 1948 US 1950	CIL 1946 CIL 1948 US 1950	CIL 1946 CIL 1948 US 1950	CIL 1946 CIL 1948 US 1950	CIL	1946	CIL 1948 US 1950	CIL 1948 US 1950	CIL 1948 US 1950	CIL 1948 US 1950	IL IL	1925 1932 1934
7	C C C	1896 1900 1903	S19 1926 S30 1929 S43 1933 S47 1934 S51 1938 S53 1943	1926 1929 1933 1934 1938 1943	IL IL IL	1914 1925 1932	C 1921 C 1923 IL 1925 C 1926 C 1930 C 1931 C 1934 IL 1932 IL 1934 C 1934 CIL 1940	1921 1923 1925 1926 1930 1931 1934 1932 1934 1934 1940	C 1921 C 1923 IL 1925 C 1926 C 1930 C 1931 C 1934 IL 1932 IL 1934 C 1934 CIL 1940	1921 1923 1925 1926 1930 1931 1934 1932 1934 1934 1940	C 1921 C 1923 IL 1925 C 1926 C 1930 C 1931 C 1934 IL 1932 IL 1934 C 1934 CIL 1940	S7 1920	C 1921 TO CIL 1940 INC.	IL 1914	IL 1914	IL 1914	IL 1914	IL 1914	IL 1914	IL	1914	IL 1914	IL 1914	IL 1914	S6 S7	1919 1920		
8	C IL C C C C C C	1913 1914 1915 1916 1917 1919 1920	S13 1922 S19 1926 S30 1929 S43 1933 S47 1934 S51 1938 S53 1943 S54 1946 S56 1948	1922 1926 1929 1933 1934 1938 1943 1946 1948	C C IL C C C IL C IL CIL	1921 1923 1925 1926 1930 1931 1932 1934 1934 1940	C 1921 C 1930 IL 1914 CIL 1948 IL 1925 IL 1932	1921 1930 1914 1948 1925 1932	C 1921 C 1923	S13 1922 S19 1926 S30 1929	CIL 1946 CIL 1948 US 1950	IL 1925 IL 1932 IL 1934	IL 1925 IL 1932 IL 1934	IL 1925 IL 1932 IL 1934	IL 1925 IL 1932 IL 1934	IL 1925 IL 1932 IL 1934	IL 1925 IL 1932 IL 1934	IL 1925 IL 1932 IL 1934	IL 1925 IL 1932 IL 1934	IL	1925	IL 1932 IL 1934	IL 1932 IL 1934	IL 1932 IL 1934	IL 1932 IL 1934	S7 S53	1920 TO 1943 INC.	
9	C C C C IL C IL CIL	1921 1923 1926 1930 1931 1932 1934 1934 1940	CAM 1898 TO 1919 INCL.	1898 1919 INCL.	B	1907	IL 1914 IL 1925 IL 1932	CIL 1946 CIL 1948 US 1950	IL 1914 IL 1925 IL 1932	IL 1914 IL 1925 IL 1932	IL 1914 IL 1925 IL 1932	IL 1914 IL 1925 IL 1932	CA 1898 TO CA 1919 INC.	IL 1914	B 1907 S6 1919 S7 1920	B 1907 S6 1919 S20 1920	B 1907 S6 1919 S7 1920	B 1907 S6 1919 S7 1920	B 1907 S6 1919 S7 1920	B 1907 S6 1919 S7 1920	B	1907	B 1907 S6 1919 S7 1920	B 1907 S6 1919 S7 1920	B 1907 S6 1919 S7 1920	S54 S56	1946 1948	

2.3.3a Producers - American Standard Beams

Depth	24		20		18		15		12		10		9		8		7		6		5		4		3-1/2 and 3	
	Ref.	Mill Year	Mill Year	Mill Year	Mill Year	Mill Year	Mill Year	Mill Year	Mill Year	Mill Year	Mill Year	Mill Year	Mill Year	Mill Year	Mill Year	Mill Year	Mill Year	Mill Year	Mill Year	Mill Year	Mill Year	Mill Year	Mill Year	Mill Year	Mill Year	Mill Year
26			K 1950	PH 1938	PA 1900 PA 1901 PA 1903	PE 1896	PE 1891	PH 1931 PH 1938	LA 1909 LA 1915 LA 1916	PE 1898 TO PE 1915 INC.	PE 1900 PE 1901	PH 1890 PH 1923 PH 1929	PH 1923 PH 1929	IN 1946	IN 1946											
27			IN 1946	K 1950	PE 1896	PE 1898 PE 1900 PE 1901	PE 1896		NJ 1889 NJ 1891	PH 1890	PH 1890	PH 1906 PH 1908 PH 1912 PH 1915	PH 1906 PH 1908 PH 1912 PH 1915													
28			PH 1906 PH 1908 PH 1912 PH 1915	IN 1946	PE 1898 PE 1900 PE 1901	PH 1890 PH 1906 PH 1908 PH 1912 PH 1915 PH 1923 PH 1929	PE 1898 PE 1900 PE 1901		PA 1897 TO PA 1903 INC.	PH 1906 TO PH 1915 INC.	PH 1906 PH 1908 PH 1912 PH 1915	PH 1906 PH 1908 PH 1912 PH 1915	PH 1906 PH 1908 PH 1912 PH 1915													
29					PH 1890 PH 1912 PH 1923	PH 1890 PH 1912 PH 1923	PH 1890		PA 1900 PA 1901 PA 1903	PH 1923 PH 1929	PH 1923 PH 1929	PH 1923 PH 1929	PH 1923 PH 1929	PH 1923 PH 1929	PH 1923 PH 1929	PH 1923 PH 1929	PH 1923 PH 1929	PH 1923 PH 1929	PH 1923 PH 1929	PH 1923 PH 1929	PH 1923 PH 1929	PH 1923 PH 1929	PH 1923 PH 1929	PH 1923 PH 1929	PH 1923 PH 1929	PH 1923 PH 1929
30					PH 1906 PH 1908 PH 1912 PH 1915 PH 1923 PH 1929	PH 1906 PH 1908 PH 1912 PH 1915 PH 1923 PH 1929	PH 1906 PH 1908 PH 1912 PH 1915		PE 1888 PE 1889 PE 1891	PH 1931	PH 1931	PH 1931	PH 1931	PH 1931	PH 1931	PH 1931	PH 1931	PH 1931	PH 1931	PH 1931	PH 1931	PH 1931	PH 1931	PH 1931	PH 1931	PH 1931
31					PH 1915 PH 1923 PH 1929	PH 1915 PH 1923 PH 1929	PH 1923 PH 1929		PE 1896	PH 1938	PH 1938	PH 1938	PH 1938	PH 1938	PH 1938	PH 1938	PH 1938	PH 1938	PH 1938	PH 1938	PH 1938	PH 1938	PH 1938	PH 1938	PH 1938	PH 1938
32					PH 1923 PH 1929 PH 1931	PH 1923 PH 1929 PH 1931	PH 1931		PE 1898 TO PE 1901 INC.	IN 1946	K 1950	IN 1946	IN 1946	IN 1946	IN 1946	IN 1946	IN 1946	IN 1946	IN 1946	IN 1946	IN 1946	IN 1946	IN 1946	IN 1946	IN 1946	IN 1946
33					PH 1931 PH 1938	PH 1931 PH 1938	PH 1938		PH 1890		IN 1946	IN 1946	IN 1946	IN 1946	IN 1946	IN 1946	IN 1946	IN 1946	IN 1946	IN 1946	IN 1946	IN 1946	IN 1946	IN 1946	IN 1946	IN 1946
34					PH 1938	K 1950	K 1950		PH 1806 TO PH 1915 INC.																	
35					K 1950	IN 1946	IN 1946		PH 1923 PH 1929																	
36									PH 1931																	
37									PH 1938																	
38									K 1950																	
39									IN 1946																	

2.3.3b Producers - Beams (Steel) WF Regular and Special

Depth	36		33		30		28		27		26		24		22		
	Mill	Year	Mill	Year	Mill	Year	Mill	Year	Mill	Year	Mill	Year	Mill	Year	Mill	Year	
1	B36a 36x16-1/2		S34	1930	S34	1930	S34	1930	S43	1933	S40	1931	B	1907	S10	1921	
	B36 36x12		S35	1930	S35	1930	S35	1930	S47	1934					S12	1922	
	S43	1933							S51	1938					S15	1924	
	S47	1934							S53	1943					S16	1925	
	36WF(B36a) 36x16-1/2								S54	1946					S18	1926	
	36WF(B36) 36x12								S56	1948							
	S51	1938															
	S53	1943															
	S54	1946															
	S56	1948															
2	G36		S40	1931	S40	1931	B	1907	S43	1933	S27	1928	S3	1909	S24	1927	
	S29	1928							S47	1934	S35	1930	S4	1911			
	S34	1930							S51	1938							
	S35	1930							S53	1943							
	G36,36X16-1/2																
	S40	1931															
3	S43	1933	S29	1928	S27	1928	S3	1909	S54	1946	B	1907	S3	1909	S27	1927	
	S47	1934	S34	1930	S34	1930	S4	1911	S56	1948			S4	1911	S29	1928	
	S51	1938	S35	1930	S35	1930							S12	1922	S35	1930	
	S53	1943											S15	1924			
4	S54	1946	B33a 33x15-3/4		B30a, 30x15		G 28		C	1913	S3	1909	S10	1921	S27	1928	
	S56	1948	B33, 33x11-1/2		B30, 30x10-1/2		B 28		C	1915	S4	1911	S12	1922	S34	1930	
			S43	1933	S43	1933	S27	1928					S15	1924	S35	1930	
			S47	1934	S47	1934	S34	1930					S16	1925			
			33WF (B33a) 33x15-3/4		30WF (B30a) 30x15		S35	1930					S18	1926			
			33WF (B33) 33x11-1/2		30WF (B30) 30x10-1/2		G28, 28x14-1/4										
			S51	1938	S51	1938	B28, 28x10										
			S53	1943	S53	1943	S40	1931									
			S54	1946	S54	1946											
			S56	1948	S56	1948											
	5	S29	1928	B33a 33x15-3/4		B	1907	S12	1922	C	1916	S12	1922	S12	1922	S24	1927
			B33, 33x11-1/2				S15	1924	C	1917	S15	1924	S15	1924	S27	1928	
			S43	1933			S16	1925	C	1919	S16	1925	S16	1925	S34	1930	
			S47	1934			S18	1926	C	1920	S18	1926	S18	1926	S35	1930	
			33WF (B33a) 33x15-3/4						C	1921							
			33WF (B33) 33x11-1/2						C	1923							
			S51	1938													
			S53	1943													
6	S29	1928	S29	1928	B30a, 30x15		S40	1931	CB 272		S24	1927	S12	1922	S34	1930	
	S34	1930			S43	1933			CB 271		S27	1928	S15	1924	S35	1930	
	S35	1930			S47	1934			C	1927	S35	1930					
					30WF (B30a) 30x15				C	1928							
					S51	1938			C	1929							
					S53	1943			CB 272, 27x14								
								CB 271, 27x9-3/4									
								C	1930								
7	S34	1930	S54	1946	S3	1909	S27	1928	CB 272		S15	1924			S40	1931	
	S35	1930	S56	1948	S4	1911	S34	1930	C	1927	S16	1925					
							S35	1930	C	1928	S18	1926					
								C	1929								
								CB272, 27x14									
								C	1930								
								C	1931								
8	S40	1931	CB332		S12	1922	S24	1927	CB 271		S12	1922	S16	1925			
			CB331		S15	1924			C	1928			S18	1926			
			C,SP	1929	S16	1925			C	1929							
			C	1929	S18	1926			CB271, 27x9-3/4								
			CB332, 33x16						C	1930							
		CB331, 33x12															
		C	1930														
9	S40	1931	C	1931	S24	1927	S15	1924	CB 271				S24	1927			
			IL	1932			S16	1925	C	1929							
							S18	1926	CB271, 27x9-3/4								
									C	1930							
10	C	1931	CB 332, 33x15-3/4		S15	1924	G28		CB272N, 27x14				S27	1928			
	IL	1932	CB 331, 33x11-1/2		S16	1925	B28		CB271N, 27x10				S35	1930			
			C	1933	S18	1926	S34	1930	C	1931							
			C	1934			S35	1930	IL	1932							
			IL	1934			G28, 28x14-1/4										
			33WF CB332, 33x15-3/4				B28, 28x10										
			33WF CB331, 33x11-1/2				S40	1931									
			CIL	1940													

Rev.
5/1/02

2.3.3b Producers - Beams (Steel) WF Regular and Special

Depth	21		20		18		16		15		14		12		10		9		8				
	Reference	Mill Year	Mill Year	Mill Year	Mill Year	Mill Year	Mill Year	Mill Year	Mill Year	Mill Year	Mill Year	Mill Year	Mill Year	Mill Year	Mill Year	Mill Year	Mill Year	Mill Year	Mill Year	Mill Year			
1	S43 1933 S47 1934 S51 1938 S53 1943	B 1907	B 1907	B 1907	B 1907	B 1907	B 1907	B 1907	B 1907	B 1907	B 1907	B 1907	B 1907	B 1907	B 1907	B 1907	B 1907	B 1907	B 1907	B 1907			
2	S43 1933 S47 1934 S51 1938 S53 1943 S54 1946 S56 1948	S3 1909 S4 1911	S3 1909 S4 1911	S3 1909 S4 1911	S24 1927 S27 1928 S35 1930	S3 1909 S4 1911	S24 1927 S27 1928 S35 1930	S3 1909 S4 1911	S24 1927 S27 1928 S35 1930	S3 1909 S4 1911	S24 1927 S27 1928 S35 1930	S3 1909 S4 1911	S3 1909 S4 1911	S3 1909 S4 1911	S3 1909 S4 1911	S3 1909 S4 1911	S3 1909 S4 1911	S3 1909 S4 1911	S3 1909 S4 1911	S3 1909 S4 1911			
3	S54 1946 S56 1948	S3 1909 S4 1911 S12 1922 S15 1924	S3 1909 S4 1911 S12 1922 S15 1924	S3 1909 S4 1911 S12 1922 S15 1924	B16a, B16 S24 1927 S27 1928 S35 1930	S3 1909 S4 1911 S12 1922 S15 1924	S24 1927 S27 1928 S35 1930	S3 1909 S4 1911 S12 1922 S15 1924	S24 1927 S27 1928 S35 1930	S3 1909 S4 1911 S12 1922 S15 1924	S24 1927 S27 1928 S35 1930	S3 1909 S4 1911 S12 1922 S15 1924	S3 1909 S4 1911 S12 1922 S15 1924	S3 1909 S4 1911 S12 1922 S15 1924	S3 1909 S4 1911 S12 1922 S15 1924	S3 1909 S4 1911 S12 1922 S15 1924	S3 1909 S4 1911 S12 1922 S15 1924	S3 1909 S4 1911 S12 1922 S15 1924	S3 1909 S4 1911 S12 1922 S15 1924	S3 1909 S4 1911 S12 1922 S15 1924			
4	IL 1913 IL 1915	S12 1922 S15 1924	S10 1921 S12 1922 S15 1924 S16 1925 S18 1926	S40 1931 S12 1922 S15 1924	S40 1931 S12 1922 S15 1924	S40 1931 S12 1922 S15 1924	S40 1931 S12 1922 S15 1924	S40 1931 S12 1922 S15 1924	S40 1931 S12 1922 S15 1924	S40 1931 S12 1922 S15 1924	S40 1931 S12 1922 S15 1924	S40 1931 S12 1922 S15 1924	S40 1931 S12 1922 S15 1924	S40 1931 S12 1922 S15 1924	S40 1931 S12 1922 S15 1924	S40 1931 S12 1922 S15 1924	S40 1931 S12 1922 S15 1924	S40 1931 S12 1922 S15 1924	S40 1931 S12 1922 S15 1924	S40 1931 S12 1922 S15 1924	S40 1931 S12 1922 S15 1924		
5	C 1916 C 1917 C 1919 C 1920	S12 1922 S15 1924 S16 1925 S18 1926	S12 1922 S15 1924 S16 1925 S18 1926	S12 1922 S15 1924 S16 1925 S18 1926	B16b, 16x11-1/2 B16a, 16x8-1/2 B16, 16x7 S43 1933 S47 1934 16WF B16b, 16x11-1/2 16WF B16a, 16x8-1/2 16WFB16, 16x7 S51 1938 S53 1943	S12 1922 S15 1924 S16 1925 S18 1926	B14a, 14x8 B14, 14x6-3/4 S43 1933 S47 1934 14WF B14a, 14x8 14WF B14, 14x6-3/4 S51 1938 S53 1943	S16 1925 S18 1926	S16 1925 S18 1926	S16 1925 S18 1926	S16 1925 S18 1926	S16 1925 S18 1926	S16 1925 S18 1926	S16 1925 S18 1926	S16 1925 S18 1926	S16 1925 S18 1926	S16 1925 S18 1926	S16 1925 S18 1926	S16 1925 S18 1926	S16 1925 S18 1926	S16 1925 S18 1926		
6	C 1921 C 1923	S16 1925 S18 1926	S12 1922 S15 1924 S16 1925 S18 1926	S12 1922 S15 1924 S16 1925 S18 1926	B16b, 16x11-1/2 B16a, 16x8-1/2 B16, 16x7 S43 1933 S47 1934 16WF B16b, 16x11-1/2 16WF B16a, 16x8-1/2 16WF B16, 16x7 S51 1938 S53 1943 S54 1946 S56 1948	S16 1925 S18 1926	B14d, 14x14-1/2 B14c, 14x12 B14b, 14x10 B14a, 14x8 B14, 14x6-3/4 S43 1933 S47 1934 14WF B14d, 14x14-1/2 14WF B14c, 14x12 14WF B14b, 14x10 14WF B14a, 14x8 14WF B14, 14x6-3/4 S51 1938 S52 1943 S54 1946 S56 1948	S24 1927	S24 1927 S27 1928 S35 1930	S24 1927 S27 1928 S35 1930	S24 1927 S27 1928 S35 1930	S24 1927 S27 1928 S35 1930	S24 1927 S27 1928 S35 1930	S24 1927 S27 1928 S35 1930	S24 1927 S27 1928 S35 1930	S24 1927 S27 1928 S35 1930	S24 1927 S27 1928 S35 1930	S24 1927 S27 1928 S35 1930	S24 1927 S27 1928 S35 1930	S24 1927 S27 1928 S35 1930			
7	C 1927	S24 1927 S18 1926	S16 1925 S18 1926	C 1927 C 1930	S24 1927 S27 1928 S35 1930	C 1927 C 1930	S24 1927 S27 1928 S35 1930	C 1927 C 1930	S24 1927 S27 1928 S35 1930	C 1927 C 1930	S24 1927 S27 1928 S35 1930	C 1927 C 1930	S24 1927 S27 1928 S35 1930	C 1927 C 1930	S24 1927 S27 1928 S35 1930	C 1927 C 1930	S24 1927 S27 1928 S35 1930	C 1927 C 1930	S24 1927 S27 1928 S35 1930	C 1927 C 1930	S24 1927 S27 1928 S35 1930		
8	CB 213 CB 212 CB 211 C 1927 C 1929 CB 213, 21x13 CB 212, 21x9 CB 211, 21x8 C 1930	S24 1927 S27 1928 S35 1930	S24 1927 S27 1928 S35 1930	C 1931 IL 1932	S27 1928 S35 1930	C 1931 IL 1932	S27 1928 S35 1930	C 1931 IL 1932	S27 1928 S35 1930	C 1931 IL 1932	S27 1928 S35 1930	C 1931 IL 1932	S27 1928 S35 1930	C 1931 IL 1932	S27 1928 S35 1930	C 1931 IL 1932	S27 1928 S35 1930	C 1931 IL 1932	S27 1928 S35 1930	C 1931 IL 1932	S27 1928 S35 1930	B8b, 8x8 B8a, 8x6-1/2 B8, 8x5-1/4 S43 1933 S47 1934 8WF B8b, 8x8 8WF B8a, 8x6-1/2 8WF B8, 8x5-1/4 S51 1938 S53 1943	
9	CB 18213 CB 18212 CB 18211 C 1929 CB 213, 21x13 CB 212, 21x9 CB 211, 21x8 C 1930	S27 1928 S35 1930	S24 1927 S27 1928 S35 1930	S27 1928 S35 1930	CB163, 16x11-1/2 CB162, 16x8-1/2 CB161, 16x7 C 1933 C 1934 IL 1934 16WF CB163, 16x11-1/2 16WF CB162, 16x8-1/2 16WF CB161, 16x7 CIL 1940	S40 1931	C 1931 IL 1932	S40 1931	C 1931 IL 1932	S40 1931	C 1931 IL 1932	S40 1931	C 1931 IL 1932	S40 1931	C 1931 IL 1932	S40 1931	C 1931 IL 1932	S40 1931	C 1931 IL 1932	S40 1931	C 1931 IL 1932	B8b, 8x8 B8a, 8x6-1/2 B8, 8x5-1/4 S43 1933 S47 1934 8WF B8b, 8x8 8WF B8a, 8x6-1/2 8WF B8, 8x5-1/4 S51 1938 S53 1943	
10	C 1931 IL 1932	S40 1931	S27 1928 S35 1930	S27 1928 S35 1930	CB163, 16x11-1/2 CB162, 16x8-1/2 CB161, 16x7 C 1933 C 1934 IL 1934 16WF CB163, 16x11-1/2 16WF CB162, 16x8-1/2 16WF CB161, 16x7 CIL 1940 CIL 1946 CIL 1948 US 1950	C 1913 C 1915	CB142, 14x8 CB141, 14x6-3/4 C 1933 C 1934 IL 1934 14WF CB142, 14x8 14WF CB141, 14x6-3/4 CIL 1940	B12C, 12x12 B12b, 12x10 B12a, 12x8 B12, 12x6-1/2 S43 1933 S47 1934 12WF B12C, 12x12 12WF B12b, 12x10 12WF B12a, 12x8 12WF B12, 12x6-1/2 S51 1938	B10b, 10x10 B10a, 10x8 B10, 10x5-3/4 S43 1933 S47 1934 10WF B10b, 10x10 10WF B10a, 10x8 10WF B10, 10x5-3/4 S51 1938 S53 1943	C 1927	C 1927	C 1927	C 1927	C 1927	C 1927	C 1927	C 1927	C 1927	C 1927	C 1927	C 1927	C 1927	S54 1946 S56 1948

2.3.3b Producers - Beams (Steel) WF Regular and Special

Depth	36		33		30		28		27		26		24		22		
	Reference	Mill	Year	Mill	Year	Mill	Year	Mill	Year	Mill	Year	Mill	Year	Mill	Year	Mill	Year
11	CB CB CSP C CB362, 36x16-1/2 CB361, 36x12 C		1929 1929 1930	CB CB C C IL 33WF CB332, 33x15-3/4 33WF CB331, 33x11-1/2 CIL CIL US	1933 1934 1934 1940 1946 1950	S12 S15 S16 S18	1922 1924 1925 1926	S12	1922	CB272, 27x14 CB271, 27x10 C C IL 27WF CB272, 27x14 27WF CB271, 27x10 CIL	1933 1934 1934 1940			S40	1931		
12	CB362, 36x16-1/2 C C IL 36WF, CB362, 36x16-1/2 CIL		1933 1934 1934 1940	CIL CIL US	1946 1948 1950	S24 S27 S34 S35	1927 1928 1930 1930			CB272, 27x14 CB271, 27x10 C C IL 27WF CB272, 27x14 27WF CB271, 27x10 CIL CIL	1933 1934 1934 1940 1946			B24b, 24x14 B24a, 24x12 B24, 24x9 S43 S47 24WF(B24b) 24x14 24WF(B24a) 24x12 24WF(B24) 24x9 S51 S53	1933 1934		
13	CB362, 36x16-1/2 CB361, 36x12 C C IL 36 WF CB362, 36x16-1/2 36 WF CB361, 36x12 CIL CIL CIL US CIL		1933 1934 1934 1940 1946 1948 1950 1946			CB 302 CB 301 C CB CB C	1927 1930			CIL CIL US	1946 1948 1950			B24b, 24x14 B24, 24x9 S43 S47 24WF(B24b) 24x14 24WF(B24) 24x14 S51 S53 S54 S56	1933 1934 1938 1943 1946 1948		
14	CIL		1946			C C C C	1927 1928 1929 1930							B24a, 24x12 S43 S47 24WF(B24a) 24x12 S51 S53 S54 S56	1933 1934 1938 1943 1946 1948		
15						CB301 & CB 302 C C CB302, 30x14 CB301, 30x10-1/2 C C IL	1928 1929 1930							S54 S56	1946 1948		
16						C IL	1931 1932							C C	1913 1915		
17						CB302, 30x15 CB301, 30x10-1/2 C C C IL 30WF CB302, 30x15 30WF CB301, 30x10-1/2 CIL	1933 1934 1934 1934 1940							C C C C	1916 1917 1919 1920		
18						CB302, 30x15 CB301, 30x10-1/2 C C IL 30WF CB302, 30x15 30WF CH301, 30x10-1/2 CIL CIL CIL US	1933 1934 1934 1940 1946 1948 1950							C C	1921 1923		
19														CB244 CB243 C CB244, 24x14 CB243, 24x12 C	1927 1930		

Rev.
5/1/02

2.3.3b Producers - Beams (Steel) WF Regular and Special																								
Depth Reference	21		20		18		16		15		14		12		10		9		8					
	Mill	Year	Mill	Year	Mill	Year	Mill	Year	Mill	Year	Mill	Year	Mill	Year	Mill	Year	Mill	Year	Mill	Year				
11	CB 213, 21x13 CB 212, 21x 9 CB 211, 21x8-1/4 C 1933 C 1934 IL 1934 21WFCB213, 21x13 21WFCB212, 21x9 21WFCB211, 21x8-1/4 CIL 1940	C 1931 IL 1932	G18 S27 S35 G18, 18x11-3/4 S40	1928 1930 1931	K 1950 K 1952	C 1916 C 1917 C 1919 C 1920	CB145, 14x14-1/2 CB144, 14x12 CB143, 14x10 CB142, 14x8 CB141, 14x6-3/4	1933 1934 1934 1934 14WF CB145, 14x14-1/2 14WF CB144, 14x12 14WF CB143, 14x10 14WF CB142, 14x8 14WF CB141, 14x6-3/4 CIL 1940 CIL 1946 CIL 1948 US 1950	B12C, 12x12 B12b, 12x10 B12a, 12x8 B12, 12x6-1/2 S43 S47 12WF B12C, 12x12 12WF B12b, 12x10 12WF B12a, 12x8 12WF B12, 12x6-1/2 S51 S54 S56	1933 1934 1938 1946 1948	S54 S56	1946 1948	B40 C 1927 C 1928 C 1929 B40, 9x5-1/4 C 1930	C 1913 C 1915	C 1913 C 1917 C 1919 C 1920 C 1921 C 1923	B40 C 1928 C 1929 B40, 9x5-1/4 C 1930	C 1916 C 1917 C 1919 C 1921 C 1923	C 1913 C 1915	C 1916 C 1917 C 1919 C 1920	C 1921 C 1923	C 1927 C 1928 C 1929 C 1930	C 1927 C 1928 C 1929 C 1930 C 1931 C 1933	C 1921 C 1923	C 1927 C 1928 C 1930
12	CB213, 21x13 CB212, 21x9 CB211, 21x8-1/4 C 1933 C 1934 IL 1934 21WF CB213, 21x13 21WFCB212, 21x9 21WF CB211, 21x8-1/4 CIL 1940 CIL 1946 CIL 1948 US 1950		B18a, 18x8-3/4 B18, 18x7-1/2 S40	1931		C 1921 C 1923	K 1950 K 1952	S54 S56	1946 1948	C 1913 C 1915	C 1916 C 1917 C 1919 C 1920 C 1921 C 1923	B40 C 1928 C 1929 B40, 9x5-1/4 C 1930	C 1913 C 1915	C 1916 C 1917 C 1919 C 1920	C 1921 C 1923	C 1927 C 1928 C 1929 C 1930	C 1927 C 1928 C 1929 C 1930 C 1931 C 1933	C 1921 C 1923	C 1927 C 1928 C 1930	C 1927 C 1928 C 1929 C 1930 C 1931 C 1933	C 1921 C 1923	C 1927 C 1928 C 1930		
13	CIL 1948 US 1950		B18b, 18x11-3/4 B18a, 18x8-3/4 B18, 18x7-1/2 S43 S47 18WFB18b, 18x11-3/4 18WFB18b, 18x8-3/4 18WFB18, 18x7-1/2 S51 S53	1938 1943		C 1931 IL 1932		C 1913 C 1915	1916 1917 1919 1920	C 1921 C 1923	C 1927 C 1928 C 1929 C 1930	C 1913 C 1915	C 1916 C 1917 C 1919 C 1920	C 1921 C 1923	C 1927 C 1928 C 1930	C 1927 C 1928 C 1929 C 1930	C 1927 C 1928 C 1929 C 1930	C 1921 C 1923	C 1927 C 1928 C 1930	C 1927 C 1928 C 1929 C 1930	C 1927 C 1928 C 1930	C 1927 C 1928 C 1930		
14	IL 1914 IL 1925		B18b, 18x11-3/4 B18a 18x8-3/4 B18, 18x7-1/2 S43 S47 18WF B18b, 18x11-3/4 18WF B18a, 18x8-3/4 18WFB18, 18x-1/2 S51 S53 S56	1938 1943 1948		IL 1914 IL 1925		C 1916 C 1917 C 1919 C 1920	C 1921 C 1923	C 1927 C 1928 C 1929 C 1930	C 1913 C 1915	C 1916 C 1917 C 1919 C 1920	C 1921 C 1923	C 1927 C 1928 C 1930	C 1927 C 1928 C 1929 C 1930	C 1927 C 1928 C 1929 C 1930	C 1927 C 1928 C 1929 C 1930	C 1921 C 1923	C 1927 C 1928 C 1930	C 1927 C 1928 C 1929 C 1930	C 1927 C 1928 C 1929 C 1930	C 1927 C 1928 C 1930		
15			C 1913 C 1915					C 1921 C 1923	1927 1928 1930	C 1927 C 1928 C 1930	C 1927 C 1928 C 1930	C 1927 C 1928 C 1930	C 1927 C 1928 C 1930	C 1927 C 1928 C 1930	C 1927 C 1928 C 1930	C 1927 C 1928 C 1930	C 1927 C 1928 C 1930	C 1927 C 1928 C 1930	C 1927 C 1928 C 1930	C 1927 C 1928 C 1930	C 1927 C 1928 C 1930	C 1927 C 1928 C 1930	C 1927 C 1928 C 1930	
16			C 1916 C 1917 C 1919 C 1920					C 1927	1928 1929 1930	C 1927 C 1928 C 1929 C 1930	C 1927 C 1928 C 1929 C 1930	C 1927 C 1928 C 1929 C 1930	C 1927 C 1928 C 1929 C 1930	C 1927 C 1928 C 1929 C 1930	C 1927 C 1928 C 1929 C 1930	C 1927 C 1928 C 1929 C 1930	C 1927 C 1928 C 1929 C 1930	C 1927 C 1928 C 1929 C 1930	C 1927 C 1928 C 1929 C 1930	C 1927 C 1928 C 1929 C 1930	C 1927 C 1928 C 1929 C 1930	C 1927 C 1928 C 1929 C 1930	C 1927 C 1928 C 1929 C 1930	
17			C 1921 C 1923					CB123 CB122 CB121 C 1927 CB123, 12x8 CB122, 12x6-1/2 CB121, 12x6 C 1930	C 1931 IL 1932	C 1931 IL 1932	C 1931 IL 1932	C 1931 IL 1932	C 1931 IL 1932	C 1931 IL 1932	C 1931 IL 1932	C 1931 IL 1932	C 1931 IL 1932	C 1931 IL 1932	C 1931 IL 1932	C 1931 IL 1932	C 1931 IL 1932	C 1931 IL 1932	C 1931 IL 1932	C 1931 IL 1932
18			CB183 CB182 CB181 C 1927 CB183, 18x12 CB182, 18x8-1/2 CB 181, 18x7-1/2 C 1930					CB 124C CB 124B CB123B C 1928 C 1929 CB124C, 12x12 CB124B, 12x12 CB123B, 12x19 C 1930	CB103, 10x10 CB102, 10x8 CB101, 10x5-3/4 C 1933 C 1934 IL 1934 10WF CB103, 10x10 10WF CB102, 10x10 10WF CB101, 10x5-3/4 CIL 1940	CB83 CB82 C 1927 C 1928 C 1930 CB83N, 8x8 CB82N, 8x6-1/2 C 1931 IL 1932	C 1931 IL 1932	C 1931 IL 1932	C 1931 IL 1932	C 1931 IL 1932	C 1931 IL 1932	C 1931 IL 1932	C 1931 IL 1932	C 1931 IL 1932	C 1931 IL 1932	C 1931 IL 1932	C 1931 IL 1932	C 1931 IL 1932	C 1931 IL 1932	C 1931 IL 1932
19			C 1931 IL 1932					C 1931 IL 1932	CB103, 10x10 CB102, 10x8 CB101, 10x5-3/4 C 1933 C 1934 IL 1934 10WF CB103, 10x10 10WF CB102, 10x10 10WF CB101, 10x5-3/4 CIL 1940 CIL 1946 CIL 1948 US 1950	C 1931 IL 1932	C 1931 IL 1932	C 1931 IL 1932	C 1931 IL 1932	C 1931 IL 1932	C 1931 IL 1932	C 1931 IL 1932	C 1931 IL 1932	C 1931 IL 1932	C 1931 IL 1932	C 1931 IL 1932	C 1931 IL 1932	C 1931 IL 1932	C 1931 IL 1932	

2.3.3b Producers - Beams (Steel) WF Regular and Special

Depth	36		33		30		28		27		26		24		22	
Reference	Mill	Year	Mill	Year	Mill	Year	Mill	Year	Mill	Year	Mill	Year	Mill	Year	Mill	Year
20													C IL	1931 1932		
21													CB243, 24x14 CB241, 24x9 C C IL 24WFCB243, 24x14 24WFCB241, 24x9 CIL	1933 1934 1933 1940		
22													CB243, 24x14 CB242, 24x12 CB241, 24x9 C C IL 24WF CB243, 24x14 24WF CB242, 24x12 24WF CB241, 24x9 CIL CIL CIL US CIL US	1933 1934 1934 1940 1946 1948 1950 1946 1950		
23													CIL US	1946 1950		
24													IL IL	1914 1925		
25																
26																

Rev.
5/1/03

2.3.3b Producers - Beams (Steel) WF Regular and Special																				
Depth	21		20		18		16		15		14		12		10		9		8	
Reference	Mill	Year	Mill	Year	Mill	Year	Mill	Year	Mill	Year	Mill	Year	Mill	Year	Mill	Year	Mill	Year	Mill	Year
20					CB183, 18x11-3/4						CB124, 12x12		CIL	1946					CB83, 8x8	
					CB182, 18x8-3/4						CB123, 12x10		CIL	1948					CB82, 8x6-1/2	
					CB181, 18x7-1/2						CB122, 12x8		US	1950					C	1933
					C	1933					CB121, 12x6-1/2		C	1933					C	1934
					C	1934					C	1934		C	1934				IL	1934
					IL	1934					IL	1934		IL	1934				8WF CB83, 8x8	
					18WF CB183, 18x11-3/4						12WF CB124, 12x12								8WF CB82, 8x6-1/2	
					18WF CB182, 18x8-3/4						12WF CB123, 12x10								CIL	1940
					18WF CB181, 18x7-1/2						12WF CB123, 12x8									
					CIL	1940					12WF CB121, 12x6-1/2									
					CIL	1946					CIL	1940								
21					CB183, 18x11-3/4						CB124, 12x12		IL	1914					CB81, 8x5-1/4	
					CB182, 18x8-3/4						CB123, 12x10		IL	1925					C	1934
					CB181, 18x7-1/2						CB122, 12x8								IL	1934
					C	1933					CB121, 12x6-1/2								8WF CB81, 8x5-1/4	
					C	1934					C	1933							CIL	1940
					IL	1934					C	1934								
					18WF CB183, 18x11-3/4						IL	1934								
					18WF CB182, 18x8-3/4						12WFCB124, 12X12									
					18WF CB181, 18x7-1/2						12WF CB123, 12x10									
					CIL	1940					12WF CB122, 12x8									
					CIL	1946					12WF CB121, 12x6-1/2									
					CIL	1948					CIL	1940								
					US	1950					CIL	1946								
					US	1950					US	1950								
22					CIL	1946					CIL	1946		K	1950				CB81, 8x5-1/4	
					CIL	1948					CIL	1948		K	1952				C	1934
					US	1950					US	1950							IL	1934
					S56	1948					US	1950							8WF CB81, 8x5-1/4	
																			CIL	1940
																			CIL	1946
																			CIL	1948
																			US	1950
23											IL	1914							CIL	1946
											IL	1925							CIL	1948
																			US	1950
24											K	1950							K	1950
											K	1952							K	1952
25																			PH	1938
26																			PH	1838A

2.3.3c Producers - WF Shapes (Steel) Light Columns and Stanchions

Depth	6		5		4	
Reference	Mill	Year	Mill	Year	Mill	Year
1	S35	1930	S47	1934	S43	1933
			S48	1934	S47	1934
			S51	1938	S51	1938
			S53	1943	S53	1943
			S54	1946		
			S56	1948		
2	S35	1930	S51	1938	BS4, 4x4	
	S39	1930	S53	1943	S43	1933
					S47	1934
					S51	1938
					S53	1943
				S54	1946	
3	S31	1931	S51	1938	S43	1933
	S33	1933	S53	1943	S47	1934
	S34	1934	S54	1946	S51	1938
			S56	1948	S53	1943
					S54	1946
				S56	1948	
4	S43	1933	C	1934	CB41	
	S47	1934	IL	1934	CIL	1946
			CIL	1940		
			CIL	1946		
5	B6		CIL	1946	C	1931
	S43	1933	CIL	1948	C	1934
	S47	1934	US	1950	IL	1934
	6WF B6, 6x6				CIL	1940
	S51	1938				
6	S51	1938	CIL	1948	CIL	1946
			US	1950	CIL	1948
					US	1950
7	S53	1943	K	1950	K	1950
			K	1952	K	1952
8	S53	1943			K	1952
	S54	1946				
	S56	1948				
9	C	1934				
	IL	1934				
10	CIL	1940				
11	CIL	1946				
	CIL	1948				
	US	1950				
12	K	1950				

2.3.3d Producers - Light Beams, Joists and Junior Beams (Steel)

Reference	Mill	Year
1	S26	1927
	S28	1928
	S35	1930
	S39	1930
2	S39	1930
3	BJ12-10-8-X4	
	S40	1931
	B12L-BIOL-B8L-X4	
	S43	1933
	S47	1934
	12BL-10BL-8BL-X4	
	S51	1938
	S53	1943
	S54	1946
S56	1948	
4	BJ12-10-8-X4	
	S43	1933
	S47	1934
	12BL-10BL-8BL-X4	
	S51	1938
	S53	1943
	S54	1946
S56	1948	
5	C	1934
	IL	1934
	CIL	1940
	CIL	1946
	CIL	1948
	US	1950
6	J&L	1931
7	S47	1934
	S48	1934
	S51	1938
	S53	1943
8	C	1933
	C	1934
9	S28	1928
	S35	1930
	S39	1930
10	S40	1931
11	BJ6, 6x4	
	S40	1931
12	S43	1933
	S47	1934
	S51	1938
	S53	1943
	S54	1946
	S56	1948
13	B6b, 6x3	
	S47	1934
	S48	1934
	6B(B6b), 6x3	
	S51	1938
S53	1943	
14	C	1934
15	J&L	1952

2.3.3e Columns (Steel)

Depth	16		14		13		12		11		10		9		8		6	
Reference	Mill	Year	Mill	Year	Mill	Year	Mill	Year	Mill	Year	Mill	Year	Mill	Year	Mill	Year	Mill	Year
1	S22	1927	B	1907	B	1907	B	1907	B	1907	B	1907	B	1907			S10	1921
																	S12	1922
																	S15	1924
																	S16	1925
																	S18	1926
2	S24	1927	S3	1909			S3	1909			S3	1909	C	1927	S3	1909	S27	1928
			S4	1911			S4	1911			S4	1911	C	1930	S4	1911	S35	1930
3	S27	1928	S10	1921			S10	1921			S10	1921			S4	1911	S33	1929
	S35	1930	S12	1922			S12	1922			S12	1922			S12	1922	S34	1930
			S15	1924			S15	1924			S15	1924					S35	1930
			S16	1925			S16	1925			S16	1925						
			S18	1926			S18	1926			S18	1926						
4	S35	1930	S12	1922			S12	1922			S12	1922			CB 82	1921	S40	1931
			S15	1924			S15	1924			S15	1924			CB 83	1922		
			S16	1925			S16	1925			S16	1925			C	1924		
			S18	1926			S18	1926			S18	1926			C	1926		
5			S27	1928			S27	1928			S27	1928			S12	1922	B6, 6x6	
			S35	1930			S35	1930							S15	1924	S43	1933
															S18	1926	S47	1934
6			S35	1930			S40	1931			S34	1930			S27	1927	S51	1938
											S35	1930			S35	1935		
7			H14e 14x16				12WF				S40	1931					6W(B6) 6x6	
			H14d 14x16				B12c 12x12										S53	1943
			H14 14x14-1/2				B12b 12x10											
			H14a 14x12				B12a 12x8											
			H14b 14x10				S43 1933											
			S40 1931				S47 1934											
			H14c 14x8				S51 1938											
			S40 1931				S53 1943											
8			B14f 14x16				B12c 12x12				10 WF				S40	1931	6 WF(B6) 6x6	
			B14e 14x16				B12b 12x10				B10b 10x10						S54	1946
			B14d 14x14-1/2				B12a 12x8				B10a 10x8						S56	1948
			B14c 14x12				S53 1946				S43 1933							
			B14b 14x10				S54 1948				S51 1938							
			B14a 14x8								S53 1943							
			S43 1933															
			S47 1934															
			S51 1938															
			S53 1943															
9			B14f 14x16				12 WF				B10b, 10x10				B8b,B8a,8x8		C	1913
			B14e 14x16				CB 127				B10a, 10x8				S43 1933		C	1915
			B14d 14x14-1/2				CB 126				S54 1946				S47 1934		C	1916
			B14c 14x12				CB 125				S56 1948				S51 1938		C	1917
			B14b 14x10				CB 124								S53 1943		C	1919
			B14a 14x8				CB 123										C	1920
			S54 1946				C 1927											
			S56 1948				12 WF											
							CB 127 12x14											
							CB 126 12x14											
							CB 125 12x12											
							CB 123 12x8											
							C 1930											
10			C 1927				CB124c 12x12				C 1927				B8b,B8a,8x8		C	1921
			C 1928				CB124b 12x12				C 1930				S54 1946			
			C 1929				CB123a 12x9								S56 1948			
			CB146, 14x15				C 1928											
			CB145, 14x12				C 1929											
			CB144, 14x10				C 1930											
			CB143, 14x8															
			C 1930															
11			C 1928				12WF				C 1928				C 1913		C	1923
			C 1929				CB125n 12x12				C 1929				C 1915		C	1926
			C 1930				CB124n 12x10				C 1930				C 1916			
							CB123n 12x8								C 1917			
							C 1931								C 1919			
							IL 1932								C 1920			

2.3.3e Columns (Steel)

Depth	16		14		13		12		11		10		9		8		6	
Reference	Mill	Year	Mill	Year	Mill	Year	Mill	Year	Mill	Year	Mill	Year	Mill	Year	Mill	Year	Mill	Year
12			C	1931			12WF CB124 12x12 CB123 12x10 CB122 12x8 C 1933 C 1934 IL 1934 CIL 1940				C 1931 IL 1932			C 1921 C 1923 C 1929 C 1930 C 1931			H3-H3a C 1927 C 1930 C 1931 IL 1932 C 1933 C 1934 IL 1934	
13			CB146, 14x16 CB145, 14x14-1/2 CB144, 14x12 CB143, 14x10 CB142, 14x8 C 1933 C 1934 CIL 1940				12WF CB124 12x12 CB123 12x10 CB122 12x8 CIL 1946 CIL 1948 US 1950				10 WF CB 103, 10x10 CB 102, 10x8 C 1933 C 1934 IL 1934 CIL 1940			C 1923 C 1929 C 1930 C 1931			C 1929 C 1931	
14			CB146, 14x16 CB145, 14x14-1/2 CB144, 14x12 CB143, 14x10 CB142, 14x8 CIL 1946 CIL 1948 US 1950								10 WF CB 103, 10x10 CB 102, 10x8 CB 101, 10x5-3/4 CIL 1946 CIL 1948 US 1950			CB 82 CB 83 C 1927 C 1930			C 1934 IL 1934	
15			IL 1934											C 1931 IL 1932			CIL 1940	
16														CB83, 8x8 CB82, 8x8 C 1933 C 1934 IL 1934 CIL 1940			CIL 1940 CIL 1946	
17														CB83, 8x8 CB82, 8x8 CIL 1946			6H, 286-287 PH 1929	
18														CIL 1948 US 1950			6H, 286-287 PH 1931 PH 1938	
19														K 1950-2			K 1950 K 1952	
20																	H3a, H3, CB56 CIL 1948 US 1950	
21																	PH 1938A	

Table 2.4.1 Dimensions and Primary Properties -- Wrought Iron Sections 1873-1900

Designation	Mill Ref	Wt. per ft lb	Area	Depth	Web Thickness	Flange Width	Average Flange Thickness	Distance	Distance	Compact Section Criteria		
			A in.2	D in.	tw in.	bf in.	tf in.	T in.	k in.	bf/2tf	h/tw	Fy" ksi
1	1	90.67	27.20	20.00	0.688	6.750	1.157	15.506	2.247	2.92	22.5	-
2	2	90.0	27.00	20.00	0.650	7.000	1.100	15.203	2.399	3.18	23.4	-
3	2	66.67	20.00	20.00	0.500	6.250	0.860	15.763	2.119	3.63	31.5	65
4	1	66.67	19.97	20.00	0.500	6.000	0.938	16.246	1.877	3.20	32.5	61
5	3	87.0	26.10	15.00	0.900	6.220	1.185	10.284	2.358	2.62	11.4	-
6	13	83.33	25.00	15.00	0.875	5.875	1.063	10.370	2.315	2.76	11.9	-
7	12	83.33	25.00	15.00	0.875	5.875	1.118	10.839	2.081	2.63	12.4	-
8	3	80.0	24.00	15.00	0.760	6.080	1.185	10.284	2.358	2.57	13.5	-
9	2	80.0	24.00	15.00	0.930	5.810	1.032	10.662	2.169	2.82	11.5	-
10	11	80.0	24.00	15.00	0.900	5.590	1.188	10.789	2.106	2.35	12.0	-
11	8	79.2	24.10	15.00	0.906	6.000	1.032	10.786	2.107	2.91	11.9	-
12	7	77.67	23.60	15.00	0.875	5.969	1.032	10.786	2.107	2.89	12.3	-
13	3	70.0	21.00	15.00	0.770	5.650	0.970	11.121	1.940	2.91	14.4	-
14	2	67.0	20.10	15.00	0.670	5.550	1.032	10.662	2.169	2.69	15.9	-
15	7, 8	67.0	20.40	15.00	0.813	5.500	0.875	11.371	1.815	3.14	14.0	-
16	1	67.0	20.10	15.00	0.625	5.000	1.163	10.949	2.026	2.15	17.5	-
17	6	66.67	20.60	15.13	0.640	5.625	1.094	10.662	2.231	2.57	16.7	-
18	4, 5	66.67	20.02	15.13	0.600	5.750	1.110	10.809	2.158	2.59	18.0	-
19	13	66.67	20.00	15.00	0.625	5.563	0.907	11.434	1.783	3.07	18.3	-
20	12	66.67	20.00	15.00	0.625	5.625	1.032	11.611	1.695	2.73	18.6	-
21	10	66.67	20.00	15.00	0.650	5.375	1.126	10.913	2.044	2.39	16.8	-
22	7	66.67	19.90	15.00	0.656	5.750	1.032	10.786	2.107	2.79	16.4	-
23	2	65.0	19.50	15.00	0.770	5.330	0.750	11.371	1.815	3.55	14.8	-
24	8	63.33	19.40	15.00	0.594	5.688	1.032	10.786	2.107	2.76	18.2	-
25	8	62.0	19.00	15.00	0.563	5.656	1.032	10.786	2.107	2.74	19.2	-
26	9	61.4	18.40	15.00	0.813	6.000	0.602	12.295	1.353	4.99	15.1	-
27	3	60.0	18.00	15.00	0.570	5.450	0.970	11.121	1.940	2.81	19.5	-
28	3	57.0	17.10	15.00	0.630	5.190	0.845	11.361	1.820	3.07	18.0	-
29	6	50.0	15.60	15.19	0.500	5.000	0.891	11.393	1.898	2.81	22.8	-
30	4, 5	50.0	15.04	15.19	0.500	5.000	0.907	11.466	1.861	2.76	22.9	-
31	3	50.0	15.00	15.00	0.490	5.050	0.845	11.361	1.820	2.99	23.2	-
32	2	50.0	15.00	15.00	0.470	5.030	0.750	11.371	1.815	3.35	24.2	-
33	12	50.0	15.00	15.00	0.500	5.000	0.772	11.731	1.635	3.24	23.5	-
34	13	50.0	15.00	15.00	0.469	5.000	0.782	11.411	1.794	3.20	24.3	-
35	10	50.0	15.00	15.00	0.500	4.750	0.875	11.684	1.658	2.71	23.4	-
36	1	50.0	15.00	15.00	0.500	4.500	0.869	11.537	1.732	2.59	23.1	-
37	7, 8	48.33	14.55	15.00	0.438	5.125	0.875	11.371	1.815	2.93	26.0	-
38	5	41.67	12.36	15.13	0.420	5.000	0.674	12.344	1.391	3.71	29.4	-
39	16	41.67	12.50	15.00	0.438	4.875	0.657	12.289	1.356	3.71	28.1	-
40	11	41.67	12.50	15.00	0.420	4.625	0.735	12.163	1.419	3.15	29.0	-
41	9	41.0	12.30	15.00	0.406	5.609	0.602	12.295	1.353	4.66	30.3	-
42	6, 7	64.67	19.90	12.00	0.875	5.719	0.969	8.121	1.940	2.95	9.3	-
43	3	60.0	18.05	12.00	0.868	5.248	0.875	8.559	1.721	3.00	9.9	-
44	2	60.0	18.00	12.00	0.960	5.090	0.782	8.913	1.544	3.26	9.3	-
45	1	60.0	18.00	12.00	0.688	4.500	1.238	8.199	1.901	1.82	11.9	-
46	5	56.67	17.60	12.25	0.660	5.250	1.032	8.079	2.086	2.54	12.2	-
47	8, 9	56.67	17.00	12.00	0.590	5.500	1.032	7.871	2.065	2.67	13.3	-
48	11	56.67	17.00	12.00	0.688	5.375	0.782	8.537	1.731	3.44	12.4	-
49	10	56.67	17.00	12.00	0.750	5.313	0.816	8.643	1.679	3.26	11.5	-
50	4	56.67	16.77	12.31	0.600	5.500	0.969	8.308	2.003	2.84	13.8	-
51	3	56.5	17.00	12.00	0.780	5.160	0.875	8.559	1.721	2.95	11.0	-
52	6, 7	56.0	16.89	12.00	0.656	5.500	0.969	8.121	1.940	2.84	12.4	-
53	6, 7	54.33	16.50	12.00	0.813	5.156	0.774	8.830	1.585	3.33	10.9	-
54	3	54.0	16.20	12.00	0.810	4.930	0.780	8.919	1.541	3.16	11.0	-
55	7	43.43	12.90	12.00	0.684	5.340	0.508	9.695	1.153	5.26	14.2	-
56	2	42.0	12.60	12.00	0.510	4.640	0.782	8.913	1.544	2.97	17.5	-
57	3	42.0	12.60	12.00	0.510	4.630	0.780	8.919	1.541	2.97	17.5	-
58	1	42.0	12.60	12.00	0.500	4.000	0.912	9.051	1.475	2.19	18.1	-
59	5	41.67	12.90	12.25	0.460	4.750	0.844	9.039	1.606	2.81	19.7	-
60	11	41.67	12.50	12.00	0.500	4.875	0.735	9.101	1.450	3.32	18.2	-
61	8, 9	41.67	12.50	12.00	0.490	4.750	0.813	8.934	1.533	2.92	18.2	-
62	10	41.67	12.50	12.00	0.500	4.688	0.739	9.197	1.402	3.17	18.4	-

Table 2.4.1 Dimensions and Primary Properties -- Wrought Iron Sections 1873-1900

Designation	Mill Ref	Wt. per ft lb	X1 ksi	X2 x 106 (1/ksi) ²	Elastic Properties						Plastic Modulus	
					lx in.4	Axis x-x Sx in.3	rx in.	ly in.4	Axis y-y Sy in.3	ry in.	Zx in.3	Zy in.3
1	1	90.67	4130	679	1650.3	165.0	7.79	46.5	13.8	1.31	200.3	25.2
2	2	90.0	3946	786	1672.8	167.3	7.87	51.8	14.8	1.38	196.7	26.1
3	2	66.67	3100	2101	1243.9	124.4	7.89	27.4	8.8	1.17	144.4	16.0
4	1	66.67	3211	1821	1238.0	123.8	7.87	26.6	8.9	1.15	148.0	16.0
5	3	87.0	6366	125	853.1	113.7	5.72	41.9	13.4	1.26	137.5	23.7
6	13	83.33	5716	198	813.0	108.4	6.38	40.8	13.9	1.28	122.9	19.0
7	12	83.33	5896	174	813.0	108.4	6.38	25.9	8.8	1.00	126.8	21.7
8	3	80.0	5878	160	813.7	108.5	5.82	38.8	12.8	1.27	129.6	22.0
9	2	80.0	6180	158	750.0	100.0	5.59	29.9	10.3	1.12	122.4	18.8
10	11	80.0	6417	131	755.1	100.7	5.61	28.9	10.3	1.10	127.3	19.5
11	8	79.2	6029	168	766.6	102.2	5.64	33.7	11.2	1.18	124.2	20.0
12	7	77.67	5893	181	757.9	101.1	5.67	33.1	11.1	1.18	122.5	19.6
13	3	70.0	5288	275	681.8	90.9	5.70	26.1	9.2	1.11	109.6	16.3
14	2	67.0	5156	280	677.0	90.3	5.80	25.4	9.2	1.12	107.8	16.0
15	7, 8	67.0	5295	300	636.8	84.9	5.59	21.9	8.0	1.04	103.6	14.5
16	1	67.0	5911	199	606.0	80.8	5.49	21.1	8.4	1.02	105.6	15.8
17	6	66.67	5246	260	708.0	93.2	5.95	27.2	9.7	1.17	112.8	17.0
18	4, 5	66.67	5038	281	707.1	94.3	5.94	27.5	9.6	1.17	113.9	17.2
19	13	66.67	4225	597	694.0	92.5	5.89	33.8	12.1	1.30	98.1	14.0
20	12	66.67	4705	404	674.0	89.9	5.83	31.0	11.0	1.57	107.2	16.6
21	10	66.67	5303	245	676.6	90.2	5.82	23.9	8.9	1.09	110.0	16.0
22	7	66.67	5152	272	682.1	90.9	5.86	28.5	9.9	1.20	110.2	17.2
23	2	65.0	4650	504	614.0	81.9	5.61	20.0	7.5	1.01	91.8	11.4
24	8	63.33	4907	317	678.9	90.5	5.92	28.0	9.8	1.20	106.7	16.6
25	8	62.0	4827	333	669.9	89.3	5.94	27.5	9.7	1.20	104.9	16.3
26	9	61.4	4707	542	551.5	73.5	5.47	19.5	6.5	1.03	90.6	12.3
27	3	60.0	4594	422	625.5	83.4	5.90	23.0	8.4	1.13	98.3	14.4
28	3	57.0	4428	542	562.0	75.9	5.73	18.8	7.2	1.05	89.9	11.7
29	6	50.0	4322	617	520.0	68.8	5.89	14.4	5.8	0.98	85.9	10.8
30	4, 5	50.0	4257	591	523.5	69.8	5.90	15.3	6.1	1.01	86.9	11.0
31	3	50.0	3998	744	522.6	69.7	5.90	15.5	6.1	1.02	82.0	10.6
32	2	50.0	3425	1364	530.0	70.6	5.94	16.3	6.5	1.04	75.0	8.9
33	12	50.0	3660	1088	518.0	69.1	5.88	17.4	6.9	1.08	77.6	10.5
34	13	50.0	3615	1101	528.0	70.4	5.93	18.3	7.3	1.10	76.6	9.5
35	10	50.0	4093	717	506.7	67.6	5.81	13.6	5.7	0.95	80.6	9.9
36	1	50.0	4432	624	463.5	61.8	5.56	12.3	5.5	0.91	77.2	9.6
37	7, 8	48.33	3984	711	521.2	69.5	5.98	16.9	6.6	1.08	82.5	11.2
38	5	41.67	3182	1902	434.5	57.9	5.93	11.6	4.7	0.97	68.5	8.2
39	16	41.67	3163	2003	430.0	57.3	5.87	13.1	5.4	1.03	66.3	7.7
40	11	41.67	3493	1420	416.2	55.5	5.77	10.3	4.4	0.90	67.6	7.9
41	9	41.0	2920	2583	438.4	58.5	5.97	15.3	5.5	1.12	67.8	9.2
42	6, 7	64.67	7102	83	411.2	68.5	4.55	27.2	9.5	1.17	83.2	16.7
43	3	60.0	6786	107	361.1	60.2	4.47	17.9	6.8	1.00	73.7	13.0
44	2	60.0	7214	96	340.0	56.7	4.35	15.5	6.1	0.93	70.7	11.7
45	1	60.0	8196	56	330.6	55.1	4.29	13.9	6.2	0.88	75.6	13.7
46	5	56.67	6413	119	385.0	63.0	4.75	20.9	8.0	1.11	77.6	13.9
47	8, 9	56.67	6211	118	381.9	63.7	4.74	24.1	8.8	1.19	76.6	15.1
48	11	56.67	5309	250	367.0	61.2	4.65	24.5	9.1	1.20	65.8	11.7
49	10	56.67	5799	186	356.0	59.3	4.57	21.9	8.2	1.14	68.6	13.0
50	4	56.67	5680	167	391.2	65.3	4.83	25.4	9.2	1.23	76.4	14.2
51	3	56.5	6316	136	348.5	58.1	4.53	17.4	6.7	1.01	70.6	12.2
52	6, 7	56.0	6186	126	372.0	62.0	4.69	23.2	8.4	1.17	75.3	14.6
53	6, 7	54.33	6246	154	328.5	54.8	4.46	16.0	6.2	0.98	66.9	11.3
54	3	54.0	6273	156	318.0	53.0	4.43	13.1	5.3	0.90	65.1	10.4
55	7	43.43	4813	467	254.4	42.4	4.44	11.4	4.3	0.94	51.8	7.9
56	2	42.0	4789	369	275.0	45.9	4.68	11.0	4.7	0.94	54.5	8.3
57	3	42.0	4786	372	274.8	45.8	4.67	11.0	4.8	0.94	54.3	8.2
58	1	42.0	5551	247	247.8	41.3	4.43	7.6	3.8	0.78	53.4	7.9
59	5	41.67	4846	340	297.0	48.6	4.87	12.2	5.1	0.99	58.4	9.2
60	11	41.67	4475	468	279.0	46.5	4.72	14.5	5.9	1.08	54.1	8.6
61	8, 9	41.67	4800	340	282.6	47.1	4.75	13.0	5.5	1.02	56.3	9.2
62	10	41.67	4314	546	278.0	46.3	4.72	13.3	5.7	1.03	52.9	8.8

Table 2.4.1 Dimensions and Primary Properties -- Wrought Iron Sections 1873-1900

Designation	Mill Ref	Wt. per ft lb	Area	Depth	Web Thickness	Flange Width	Average Flange Thickness	Distance	Distance	Compact Section Criteria		
			A in.2	D in.	tw in.	bf in.	tf in.	T in.	k in.	bf/2tf	h/tw	Fy" ksi
63	4	41.67	12.33	12.25	0.470	4.790	0.782	8.745	1.753	3.06	18.6	-
64	6, 7	40.0	11.95	12.00	0.453	4.797	0.774	8.830	1.585	3.10	19.5	-
65	4	40.0	11.73	12.00	0.430	4.750	0.782	8.495	1.753	3.04	19.8	-
66	11	33.33	10.00	12.00	0.438	4.438	0.563	9.143	1.429	3.94	20.9	-
67	9	32.0	9.60	12.00	0.375	4.500	0.610	9.268	1.366	3.69	24.7	-
68	7	29.83	8.95	12.00	0.344	5.000	0.508	9.695	1.153	4.92	28.2	-
69	7, 8	53.67	16.06	10.50	0.719	5.500	0.891	7.289	1.606	3.09	10.1	-
70	6	45.0	13.96	10.50	0.530	5.000	0.938	6.913	1.794	2.67	13.0	-
71	11	45.0	13.50	10.50	0.531	5.000	0.891	7.039	1.731	2.81	13.3	-
72	9	45.0	13.50	10.50	0.500	5.000	0.938	6.934	1.783	2.67	13.9	-
73	10	45.0	13.50	10.50	0.500	5.000	0.882	7.411	1.545	2.83	14.8	-
74	3	45.0	13.50	10.50	0.695	4.945	0.735	7.759	1.370	3.36	11.2	-
75	2	45.0	13.50	10.50	0.790	4.920	0.625	7.893	1.304	3.94	10.0	-
76	7	45.0	13.45	10.50	0.656	5.125	0.735	7.663	1.419	3.49	11.7	-
77	4, 5	45.0	13.36	10.50	0.470	5.000	0.954	6.433	2.034	2.62	13.7	-
78	7, 8	44.67	13.44	10.50	0.469	5.250	0.891	7.289	1.606	2.95	15.5	-
79	3	40.0	12.00	10.50	0.550	4.800	0.735	7.759	1.370	3.27	14.1	-
80	7, 8	36.33	10.91	10.50	0.531	4.688	0.641	7.955	1.273	3.66	15.0	-
81	7, 8	36.0	10.83	10.50	0.406	4.875	0.735	7.663	1.419	3.32	18.9	-
82	6	35.0	10.96	10.50	0.410	4.500	0.813	7.163	1.669	2.77	17.5	-
83	3	35.0	10.57	10.50	0.512	4.642	0.625	7.893	1.304	3.71	15.4	-
84	9	35.0	10.50	10.50	0.440	4.500	0.704	7.558	1.471	3.20	17.2	-
85	10	35.0	10.50	10.50	0.500	4.438	0.627	7.921	1.290	3.54	15.8	-
86	11	35.0	10.50	10.50	0.500	4.375	0.719	7.079	1.711	3.04	14.2	-
87	4, 5	35.0	10.44	10.50	0.375	4.500	0.782	6.871	1.815	2.88	18.3	-
88	2, 3	31.5	9.50	10.50	0.410	4.540	0.625	7.893	1.304	3.63	19.3	-
89	6	30.0	9.24	10.50	0.340	4.375	0.703	7.310	1.595	3.11	21.5	-
90	9	30.0	9.00	10.50	0.375	4.375	0.641	7.746	1.377	3.41	20.7	-
91	10	30.0	9.00	10.50	0.438	4.125	0.555	8.065	1.218	3.72	18.4	-
92	11	30.0	9.00	10.50	0.406	4.125	0.672	7.267	1.617	3.07	17.9	-
93	5	30.0	8.90	10.50	0.313	4.500	0.688	7.121	1.690	3.27	22.8	-
94	7, 8	29.67	8.94	10.50	0.344	4.500	0.641	7.955	1.273	3.51	23.1	-
95	3	50.0	15.00	10.00	0.740	4.990	0.895	6.575	1.712	2.79	8.9	-
96	4	45.67	13.95	10.00	0.750	4.875	0.782	7.122	1.439	3.12	9.5	-
97	2	45.0	13.50	10.00	0.770	4.770	0.719	7.143	1.429	3.32	9.3	-
98	3	42.0	12.60	10.00	0.500	4.750	0.895	6.575	1.712	2.65	13.2	-
99	3	41.0	12.30	10.00	0.590	4.650	0.780	7.019	1.490	2.98	11.9	-
100	1	38.0	11.40	10.00	0.625	4.125	0.705	7.465	1.268	2.93	11.9	-
101	4	37.33	11.17	10.00	0.500	4.625	0.782	7.122	1.439	2.96	14.2	-
102	3	36.0	10.80	10.00	0.440	4.500	0.780	7.019	1.490	2.88	16.0	-
103	4	35.3333	10.80	10.00	0.500	4.531	0.719	7.414	1.293	3.15	14.8	-
104	5	35.0	10.50	10.00	0.500	4.625	0.688	7.206	1.397	3.36	14.4	-
105	3	35.0	10.50	10.00	0.520	4.460	0.675	7.259	1.370	3.30	14.0	-
106	1	30.0	9.00	10.00	0.500	3.875	0.572	7.931	1.035	3.39	15.9	-
107	4	30.0	9.04	10.00	0.344	4.375	0.719	7.414	1.293	3.04	21.6	-
108	2	30.0	9.00	10.00	0.320	4.320	0.719	7.143	1.429	3.00	22.3	-
109	5	30.0	9.00	10.00	0.438	4.375	0.594	7.456	1.272	3.68	17.0	-
110	3	30.0	9.00	10.00	0.370	4.310	0.675	7.259	1.370	3.19	19.6	-
111	9	50.0	15.00	9.00	0.600	5.375	1.032	5.413	1.794	2.61	9.0	-
112	2	50.0	15.00	9.00	0.910	5.100	0.813	5.789	1.606	3.14	6.4	-
113	3	50.0	15.00	9.00	0.840	5.090	0.875	5.408	1.796	2.91	6.4	-
114	2	45.0	13.50	9.00	0.750	4.940	0.813	5.789	1.606	3.04	7.7	-
115	4	41.67	12.42	9.00	0.570	4.500	0.888	5.899	1.551	2.53	10.3	-
116	5	41.67	12.33	9.00	0.570	4.500	0.969	4.954	2.023	2.32	8.7	-
117	7	40.67	12.33	9.00	0.750	4.719	0.703	6.060	1.470	3.36	8.1	-
118	8	40.13	12.18	9.00	0.750	5.094	0.626	6.204	1.398	4.07	8.3	-
119	3	38.5	11.60	9.00	0.460	4.710	0.875	5.442	1.779	2.69	11.8	-
120	3	38.0	11.40	9.00	0.714	4.474	0.660	6.279	1.361	3.39	8.8	-
121	2	33.0	9.90	9.00	0.580	4.330	0.625	6.393	1.304	3.46	11.0	-
122	8	30.23	9.08	9.00	0.406	4.750	0.626	6.204	1.398	3.80	15.3	-
123	7	30.0	9.07	9.00	0.406	4.375	0.703	6.060	1.470	3.11	14.9	-
124	10	30.0	9.00	9.00	0.563	4.438	0.468	6.739	1.131	4.74	12.0	-

Table 2.4.1 Dimensions and Primary Properties -- Wrought Iron Sections 1873-1900

Designation	Mill Ref	Wt. per ft lb	X1 ksi	X2 x 106 (1/ksi) ²	Elastic Properties						Plastic Modulus	
					lx in.4	Sx in.3	rx in.	ly in.4	Sy in.3	ry in.	Zx in.3	Zy in.3
63	4	41.67	4593	399	288.0	48.0	4.83	11.5	4.8	0.97	56.2	8.7
64	6, 7	40.0	4580	405	272.9	45.5	4.78	12.2	5.1	1.01	54.0	8.7
65	4	40.0	4431	418	281.3	46.9	4.90	16.8	7.1	1.19	53.2	8.4
66	11	33.33	3792	983	218.0	36.3	4.66	8.7	3.9	0.94	41.4	5.5
67	9	32.0	3967	876	201.7	33.6	4.58	7.6	3.4	0.89	42.1	6.1
68	7	29.83	3106	2014	204.1	34.0	4.78	9.0	3.6	1.00	39.5	6.1
69	7, 8	53.67	6754	91	265.8	50.6	4.07	22.2	8.1	1.18	60.6	13.7
70	6	45.0	6721	96	227.0	43.2	4.10	16.1	6.4	1.09	54.5	11.1
71	11	45.0	5944	133	239.0	45.5	4.17	17.9	7.2	1.15	52.7	10.5
72	9	45.0	6296	104	240.6	45.8	4.23	16.7	6.7	1.11	54.0	11.2
73	10	45.0	5541	177	239.0	45.5	4.21	19.1	7.6	1.19	52.0	11.6
74	3	45.0	6077	155	215.7	41.1	4.00	11.6	4.7	0.93	49.6	9.5
75	2	45.0	6562	134	201.0	38.3	3.86	10.7	4.3	0.89	47.2	8.3
76	7	45.0	5865	171	219.5	41.8	4.04	14.8	5.8	1.04	50.1	9.9
77	4, 5	45.0	6367	102	233.7	44.5	4.18	15.8	6.3	1.09	54.0	11.1
78	7, 8	44.67	5762	146	241.6	46.0	4.24	19.0	7.2	1.19	53.8	11.9
79	3	40.0	5341	234	201.7	38.4	4.10	12.0	5.0	1.00	45.6	8.5
80	7, 8	36.33	4909	346	180.4	34.4	4.07	9.6	4.1	0.94	40.8	7.1
81	7, 8	36.0	4772	319	195.4	37.2	4.25	12.5	5.1	1.07	43.2	8.4
82	6	35.0	5585	198	182.0	34.6	4.16	9.2	4.1	0.94	43.3	7.6
83	3	35.0	4815	374	174.8	33.3	4.07	8.7	3.8	0.91	39.5	6.6
84	9	35.0	5008	309	175.4	33.4	4.09	9.0	4.0	0.93	40.0	6.9
85	10	35.0	4550	457	176.0	33.5	4.09	9.7	4.4	0.96	38.2	6.8
86	11	35.0	5303	243	176.0	33.5	4.08	9.5	4.4	0.95	40.9	6.6
87	4, 5	35.0	5081	252	185.6	35.4	4.22	9.4	4.2	0.95	41.5	7.3
88	2, 3	31.5	4349	511	165.0	31.4	4.17	8.0	3.5	0.92	36.7	6.1
89	6	30.0	4637	378	163.0	31.0	4.26	8.0	3.6	0.94	37.0	6.1
90	9	30.0	4355	492	158.7	30.2	4.20	7.6	3.5	0.92	35.6	5.9
91	10	30.0	4015	751	151.0	29.0	4.00	7.0	3.4	0.88	32.4	5.2
92	11	30.0	4800	359	151.0	29.0	4.12	7.4	3.6	0.90	35.6	5.4
93	5	30.0	4474	400	164.0	31.2	4.29	8.1	3.6	0.95	36.7	6.3
94	7, 8	29.67	4111	583	162.3	30.9	4.26	8.3	3.7	0.97	35.7	6.2
95	3	50.0	7436	65	218.8	43.8	3.82	16.2	6.5	1.04	53.0	11.4
96	4	45.67	6962	91	198.6	39.7	3.77	13.2	5.4	0.97	48.4	9.7
97	2	45.0	6968	97	187.0	37.5	3.73	11.3	4.7	0.91	45.8	8.7
98	3	42.0	6314	107	198.8	39.8	3.97	13.7	5.8	1.04	47.0	9.7
99	3	41.0	6132	139	183.1	36.6	3.86	11.2	4.8	0.96	43.8	8.4
100	1	38.0	5458	216	173.0	34.6	3.90	8.3	4.0	0.85	38.6	6.8
101	4	37.33	5741	166	173.6	34.7	3.94	10.6	4.6	0.98	42.1	8.1
102	3	36.0	5467	195	170.6	34.1	3.97	10.0	4.5	0.96	40.1	7.5
103	4	35.3333	5328	232	166.0	33.2	3.92	9.5	4.2	0.94	39.3	7.2
104	5	35.0	5320	236	161.0	32.2	3.92	11.1	4.8	1.03	38.8	7.0
105	3	35.0	5322	244	158.3	31.7	3.88	8.4	3.8	0.89	37.7	6.6
106	1	30.0	4184	601	141.5	28.3	3.97	6.4	3.3	0.84	30.7	4.8
107	4	30.0	4813	305	148.3	29.7	4.05	8.1	3.7	0.95	35.4	6.5
108	2	30.0	4710	323	150.0	30.0	4.09	7.9	3.7	0.94	34.6	6.2
109	5	30.0	4580	432	139.0	27.8	3.93	8.3	3.8	0.96	32.8	5.4
110	3	30.0	4645	363	145.8	29.2	4.03	7.4	3.4	0.91	34.0	5.9
111	9	50.0	8430	33	189.1	42.0	3.55	23.2	8.6	1.24	51.3	14.5
112	2	50.0	9024	33	169.0	37.5	3.34	15.7	6.2	1.02	46.2	11.2
113	3	50.0	8906	33	173.2	38.5	3.40	16.8	6.6	1.06	47.1	11.7
114	2	45.0	7928	51	159.0	35.3	3.42	14.0	5.7	1.01	42.9	10.0
115	4	41.67	7191	69	150.8	33.5	3.48	11.2	5.0	0.95	39.9	9.6
116	5	41.67	7721	50	150.8	33.5	3.50	11.2	5.0	0.95	41.8	9.2
117	7	40.67	7571	66	141.4	31.4	3.39	11.1	4.7	0.95	38.3	8.4
118	8	40.13	7248	80	139.5	31.0	3.38	12.3	4.8	1.01	37.9	8.6
119	3	38.5	6863	74	150.1	33.4	3.61	12.8	5.5	1.05	39.4	9.1
120	3	38.0	7149	85	129.4	28.8	3.65	8.8	3.9	0.88	35.1	7.1
121	2	33.0	6078	153	117.0	26.0	3.44	7.1	3.3	0.85	31.3	5.9
122	8	30.23	5191	235	118.5	26.3	3.63	9.7	4.1	1.03	30.9	6.8
123	7	30.0	5614	168	118.8	26.4	3.62	8.4	3.9	0.96	31.3	6.5
124	10	30.0	5100	321	106.0	23.6	3.42	7.4	3.3	0.91	26.9	5.2

Table 2.4.1 Dimensions and Primary Properties -- Wrought Iron Sections 1873-1900

Designation	Mill Ref	Wt. per ft lb	Area	Depth	Web Thickness	Flange Width	Average Flange Thickness	Distance	Distance	Compact Section Criteria		
			A	D	tw	bf	tf	T	k	bf/2tf	h/tw	Fy" ksi
			in.2	in.	in.	in.	in.	in.	in.			
125	11	30.0	9.00	9.00	0.500	4.375	0.641	6.184	1.408	3.41	12.4	-
126	1	30.0	9.00	9.00	0.625	4.000	0.454	6.767	1.117	4.41	10.8	-
127	7	29.33	8.93	9.00	0.500	4.328	0.578	6.310	1.345	3.74	12.6	-
128	8	28.73	8.74	9.00	0.500	4.437	0.539	6.549	1.225	4.12	13.1	-
129	3	28.5	8.60	9.00	0.400	4.160	0.660	6.279	1.361	3.15	15.7	-
130	6	28.33	8.67	9.00	0.410	3.875	0.719	5.872	1.564	2.69	14.3	-
131	5	28.33	8.50	9.00	0.375	4.500	0.657	5.830	1.585	3.43	15.5	-
132	10	28.33	8.50	9.00	0.438	4.250	0.557	6.561	1.220	3.82	15.0	-
133	11	28.33	8.50	9.00	0.438	4.250	0.657	6.122	1.439	3.24	14.0	-
134	4	28.33	8.32	9.00	0.380	4.000	0.634	6.407	1.297	3.15	16.9	-
135	3	28.0	8.40	9.00	0.489	4.109	0.560	6.519	1.240	3.67	13.3	-
136	9	28.0	8.40	9.00	0.400	4.000	0.719	5.621	1.690	2.78	14.1	-
137	8	23.51	7.06	9.00	0.313	4.250	0.539	6.549	1.225	3.94	20.9	-
138	3	23.5	7.10	9.00	0.340	3.960	0.560	6.519	1.240	3.54	19.2	-
139	2	23.5	7.00	9.00	0.260	4.010	0.625	6.393	1.304	3.21	24.6	-
140	6	23.33	7.26	9.00	0.320	3.500	0.688	5.996	1.502	2.54	18.7	-
141	10	23.33	7.00	9.00	0.375	4.125	0.442	6.791	1.105	4.67	18.1	-
142	11	23.33	7.00	9.00	0.375	4.000	0.579	6.246	1.377	3.46	16.7	-
143	5	23.33	7.00	9.00	0.300	4.000	0.594	6.080	1.460	3.37	20.3	-
144	1	23.33	7.00	9.00	0.438	3.750	0.415	6.845	1.078	4.52	15.6	-
145	9	23.33	7.00	9.00	0.310	3.500	0.625	6.080	1.460	2.80	19.6	-
146	7	23.33	6.98	9.00	0.297	4.125	0.578	6.310	1.345	3.57	21.2	-
147	4	23.33	6.53	9.00	0.300	3.500	0.550	6.575	1.213	3.18	21.9	-
148	3	40.0	12.00	8.00	0.728	4.728	0.775	4.939	1.531	3.05	6.8	-
149	6	36.67	11.09	8.00	0.750	4.625	0.657	5.351	1.325	3.52	7.1	-
150	2	35.0	10.50	8.00	0.790	4.290	0.594	5.622	1.189	3.61	7.1	-
151	3	34.0	10.20	8.00	0.500	4.500	0.775	4.939	1.531	2.90	9.9	-
152	3	31.0	9.30	8.00	0.562	4.242	0.660	5.319	1.340	3.21	9.5	-
153	6	27.0	8.14	8.00	0.375	4.250	0.657	5.351	1.325	3.24	14.3	-
154	7	27.0	8.10	8.00	0.375	4.500	0.625	5.184	1.408	3.60	13.8	-
155	3	27.0	8.10	8.00	0.410	4.090	0.660	5.319	1.340	3.10	13.0	-
156	1	27.0	8.10	8.00	0.625	3.750	0.447	5.781	1.110	4.19	9.2	-
157	5	26.67	8.36	8.00	0.370	4.125	0.719	4.872	1.564	2.87	13.2	-
158	4	26.67	8.03	8.00	0.375	4.500	0.610	5.142	1.429	3.69	13.7	-
159	8, 9	26.67	8.00	8.00	0.500	4.156	0.563	5.246	1.377	3.69	10.5	-
160	6	25.0	7.65	8.00	0.438	4.125	0.563	5.372	1.314	3.67	12.3	-
161	3	25.0	7.60	8.00	0.463	3.843	0.560	5.680	1.160	3.43	12.3	-
162	2	22.0	6.60	8.00	0.310	3.810	0.594	5.622	1.189	3.21	18.1	-
163	5	21.67	6.63	8.00	0.310	4.000	0.563	5.372	1.314	3.56	17.3	-
164	6	21.67	6.53	8.00	0.313	4.000	0.563	5.372	1.314	3.56	17.2	-
165	7	21.67	6.50	8.00	0.380	4.000	0.532	5.434	1.283	3.76	14.3	-
166	9	21.67	6.50	8.00	0.313	4.000	0.594	5.246	1.377	3.37	16.8	-
167	8	21.67	6.50	8.00	0.313	4.000	0.563	5.246	1.377	3.55	16.8	-
168	4	21.67	6.37	8.00	0.300	4.000	0.547	5.477	1.262	3.66	18.3	-
169	3	21.5	6.50	8.00	0.330	3.710	0.560	5.680	1.160	3.31	17.2	-
170	1	21.5	6.45	8.00	0.375	3.375	0.557	5.961	1.020	3.03	15.9	-
171	7	29.33	8.94	7.00	0.750	4.125	0.547	4.706	1.147	3.77	6.3	-
172	7	29.33	8.84	7.00	0.750	4.125	0.532	4.768	1.116	3.88	6.4	-
173	3	25.0	7.50	7.00	0.509	3.949	0.580	4.680	1.160	3.40	9.2	-
174	2	25.0	7.50	7.00	0.530	3.910	0.563	4.748	1.126	3.48	9.0	-
175	8	23.0	6.90	7.00	0.375	4.000	0.625	4.289	1.356	3.20	11.4	-
176	3	22.0	6.60	7.00	0.380	3.820	0.580	4.680	1.160	3.29	12.3	-
177	7	21.93	6.58	7.00	0.438	3.813	0.547	4.706	1.147	3.49	10.7	-
178	10	21.67	6.50	7.00	0.453	3.563	0.547	4.706	1.147	3.26	10.4	-
179	9	21.67	6.50	7.00	0.438	3.563	0.527	5.021	0.990	3.38	11.5	-
180	3	21.0	6.30	7.00	0.389	3.649	0.545	4.740	1.130	3.35	12.2	-
181	6	20.0	6.00	7.00	0.400	3.500	0.547	4.706	1.147	3.20	11.8	-
182	1	20.0	6.00	7.00	0.438	3.375	0.476	5.123	0.939	3.55	11.7	-
183	4	20.0	5.84	7.00	0.375	3.500	0.492	5.091	0.955	3.56	13.6	-
184	5	18.33	5.50	7.00	0.300	3.750	0.501	4.611	1.194	3.75	15.4	-
185	8	18.33	5.50	7.00	0.350	3.500	0.563	4.539	1.231	3.11	13.0	-
186	10	18.33	5.50	7.00	0.328	3.438	0.563	4.477	1.262	3.06	13.6	-
187	9	18.33	5.50	7.00	0.313	3.438	0.495	4.885	1.058	3.47	15.6	-

Table 2.4.1 Dimensions and Primary Properties -- Wrought Iron Sections 1873-1900

Designation	Mill Ref	Wt. per ft lb	X1 ksi	X2 x 106 (1/ksi) ²	Elastic Properties						Plastic Modulus	
					lx in.4	Sx in.3	rx in.	ly in.4	Sy in.3	ry in.	Zx in.3	Zy in.3
125	11	30.0	5966	154	110.0	24.4	3.50	8.2	3.7	0.95	30.8	6.1
126	1	30.0	4798	321	120.0	26.7	3.65	7.6	3.8	0.92	25.8	4.4
127	7	29.33	5493	219	108.5	24.1	3.49	6.7	3.1	0.87	28.7	5.4
128	8	28.73	5214	273	106.1	23.6	3.48	6.8	3.1	0.88	28.0	5.3
129	3	28.5	5283	225	110.3	24.5	3.59	6.8	3.3	0.89	28.7	5.5
130	6	28.33	5965	154	104.5	23.3	3.50	6.3	3.3	0.87	28.8	5.2
131	5	28.33	5309	209	111.9	24.9	3.63	7.4	3.3	0.93	30.0	5.9
132	10	28.33	4678	385	107.5	23.9	3.56	7.7	3.6	0.95	26.8	5.4
133	11	28.33	5689	174	107.0	23.8	3.54	7.6	3.6	0.94	29.7	5.8
134	4	28.33	4901	306	106.5	23.7	3.58	5.6	2.8	0.82	26.9	5.4
135	3	28.0	5274	263	101.4	22.5	3.47	5.3	2.6	0.80	26.9	4.7
136	9	28.0	5687	155	110.9	24.7	3.63	6.3	3.1	0.86	29.4	5.4
137	8	23.51	4234	513	94.7	21.1	3.66	5.9	2.8	0.91	24.3	4.6
138	3	23.5	4470	438	92.3	20.5	3.62	4.6	2.3	0.81	23.9	4.1
139	2	23.5	4482	370	97.5	21.7	3.73	5.5	2.7	0.88	24.8	4.6
140	6	23.33	5426	219	89.0	19.8	3.56	3.6	2.0	0.71	24.6	4.0
141	10	23.33	3874	833	89.0	19.8	3.56	5.7	2.7	0.90	21.8	4.0
142	11	23.33	5424	243	83.0	18.4	3.45	5.4	2.7	0.88	25.2	4.4
143	5	23.33	4581	369	93.9	20.9	3.66	4.9	2.5	0.84	24.5	4.3
144	1	23.33	3373	1034	105.8	23.5	3.89	5.3	2.8	0.87	20.7	3.3
145	9	23.33	4904	327	87.0	19.3	3.53	3.6	2.1	0.72	22.9	3.6
146	7	23.33	4503	391	94.4	21.0	3.68	5.6	2.7	0.89	24.6	4.6
147	4	23.33	4163	575	85.6	19.0	3.62	3.5	2.0	0.73	20.9	3.5
148	3	40.0	8605	36	111.7	27.9	3.05	11.9	5.0	1.00	33.9	8.8
149	6	36.67	8167	48	100.4	25.1	3.01	9.8	4.2	0.94	30.6	7.5
150	2	35.0	8450	48	90.4	22.6	2.94	7.0	3.2	0.82	28.0	6.1
151	3	34.0	7239	62	102.0	25.5	3.16	10.0	4.5	0.99	30.3	7.5
152	3	31.0	6858	87	89.0	22.3	3.09	7.1	3.3	0.87	26.7	5.9
153	6	27.0	5845	142	83.9	21.0	3.21	7.2	3.4	0.94	24.6	5.7
154	7	27.0	5755	150	84.4	21.1	3.23	7.7	3.4	0.98	24.9	5.9
155	3	27.0	6008	131	82.5	20.6	3.19	6.3	3.1	0.88	24.3	5.2
156	1	27.0	5619	183	82.0	20.5	3.18	5.4	2.9	0.82	20.6	3.8
157	5	26.67	6714	90	81.5	20.4	3.19	7.0	3.4	0.94	25.5	5.7
158	4	26.67	5668	159	83.9	21.0	3.23	7.6	3.4	0.97	24.5	5.7
159	8, 9	26.67	6180	134	77.0	19.3	3.10	6.6	3.2	0.91	23.2	4.7
160	6	25.0	5711	173	75.9	19.0	3.15	5.7	2.7	0.86	22.4	4.7
161	3	25.0	5669	190	73.0	18.3	3.10	4.2	2.2	0.74	21.4	4.1
162	2	22.0	5046	246	69.9	17.5	3.25	4.6	2.4	0.83	20.3	4.0
163	5	21.67	4997	255	71.0	17.7	3.30	5.0	2.5	0.88	20.4	4.2
164	6	21.67	5089	241	69.2	17.3	3.25	5.0	2.5	0.88	20.4	4.2
165	7	21.67	5116	240	68.5	17.1	3.25	4.6	2.3	0.84	20.4	4.0
166	9	21.67	5378	191	69.0	17.3	3.26	5.8	2.9	0.95	21.2	4.4
167	8	21.67	5224	222	68.0	17.0	3.26	5.8	2.9	0.95	20.4	4.1
168	4	21.67	4873	288	67.4	16.9	3.25	4.6	2.3	0.85	19.8	4.0
169	3	21.5	4997	282	66.2	16.5	3.20	4.0	2.1	0.78	19.3	3.6
170	1	21.5	4494	389	69.0	17.3	3.27	4.0	2.4	0.79	18.4	3.4
171	7	29.33	9010	35	59.7	17.1	2.58	5.7	2.7	0.80	21.1	5.1
172	7	29.33	8964	37	58.8	16.8	2.58	5.6	2.7	0.79	20.8	5.0
173	3	25.0	6899	83	55.6	15.9	2.72	5.2	2.6	0.83	19.0	4.5
174	2	25.0	7005	83	54.3	15.5	2.69	4.9	2.5	0.81	18.7	4.4
175	8	23.0	6517	87	55.7	15.9	2.84	5.4	2.7	0.89	19.0	4.7
176	3	22.0	6080	123	51.9	14.8	2.80	4.6	2.4	0.83	17.4	4.0
177	7	21.93	6328	114	49.8	14.2	2.75	4.2	2.2	0.79	17.2	3.9
178	10	21.67	6440	112	48.0	13.7	2.72	4.1	2.3	0.79	16.5	3.4
179	9	21.67	5515	189	50.5	14.4	2.79	4.7	2.7	0.85	16.0	3.6
180	3	21.0	5956	143	47.9	13.7	2.76	3.5	1.9	0.75	16.2	3.5
181	6	20.0	6163	128	45.0	12.9	2.74	3.2	1.8	0.73	15.8	3.3
182	1	20.0	5858	191	41.3	11.8	2.62	3.1	1.8	0.72	14.5	3.0
183	4	20.0	5124	266	44.5	12.7	2.76	3.1	1.7	0.72	14.6	3.2
184	5	18.33	5266	211	44.3	12.7	2.84	3.9	2.1	0.84	14.9	3.3
185	8	18.33	6015	124	44.2	12.6	2.83	3.3	1.9	0.77	15.7	3.3
186	10	18.33	5976	133	43.0	12.3	2.80	3.5	2.0	0.80	15.2	3.1
187	9	18.33	4871	293	44.0	12.6	2.83	3.8	2.2	0.84	13.9	3.1

Table 2.4.1 Dimensions and Primary Properties -- Wrought Iron Sections 1873-1900

Designation	Mill Ref	Wt. per ft lb	Area	Depth	Web Thickness	Flange Width	Average Flange Thickness	Distance	Distance	Compact Section Criteria		
			A in.2	D in.	tw in.	bf in.	tf in.	T in.	k in.	bf/2tf	h/tw	Fy" ksi
188	2	18.0	5.40	7.00	0.230	3.610	0.563	4.748	1.126	3.21	20.6	-
189	3	18.0	5.40	7.00	0.260	3.520	0.545	4.740	1.130	3.23	18.2	-
190	7	17.13	5.14	7.00	0.234	3.609	0.532	4.768	1.116	3.40	20.4	-
191	8	41.0	12.30	6.00	0.750	5.375	0.844	2.411	1.794	3.18	3.2	-
192	6	40.0	12.66	6.00	0.750	5.250	0.907	2.161	1.919	2.90	2.9	-
193	5	40.0	11.84	6.00	0.625	5.250	0.907	2.245	1.878	2.90	3.6	-
194	8	38.5	11.55	6.00	0.625	5.250	0.844	2.411	1.794	3.11	3.9	-
195	8	32.53	9.76	6.00	0.625	5.000	0.688	2.787	1.606	3.64	4.5	-
196	8	30.33	9.00	6.00	0.500	4.875	0.688	2.787	1.606	3.55	5.6	-
197	6	30.0	9.04	6.00	0.570	4.875	0.589	3.097	1.452	4.14	5.4	-
198	5	30.0	8.70	6.00	0.500	5.000	0.657	2.745	1.628	3.81	5.5	-
199	8	27.87	8.24	6.00	0.750	4.313	0.532	3.161	1.419	4.06	4.2	-
200	7	21.0	6.50	6.00	0.625	3.375	0.501	3.161	1.419	3.37	5.1	-
201	7	21.0	6.41	6.00	0.625	3.375	0.485	3.225	1.387	3.48	5.2	-
202	8	18.97	5.65	6.00	0.500	3.750	0.406	3.475	1.262	4.62	7.0	-
203	8	18.5	5.47	6.00	0.281	3.844	0.532	3.161	1.419	3.62	11.3	-
204	2	18.0	5.40	6.00	0.460	3.460	0.438	4.102	0.949	3.95	8.9	-
205	3	18.0	5.40	6.00	0.350	3.540	0.515	3.816	1.092	3.44	10.9	-
206	7	16.67	5.04	6.00	0.406	3.156	0.501	3.830	1.085	3.15	9.4	-
207	6	16.67	5.00	6.00	0.390	3.500	0.406	4.263	0.869	4.31	10.9	-
208	9	16.67	5.00	6.00	0.310	3.500	0.532	3.413	1.294	3.29	11.0	-
209	10	16.67	5.00	6.00	0.313	3.438	0.465	3.945	1.028	3.70	12.6	-
210	11	16.67	5.00	6.00	0.406	3.281	0.453	3.789	1.106	3.62	9.3	-
211	4	16.67	4.91	6.00	0.300	3.500	0.516	3.748	1.126	3.39	12.5	-
212	3	16.0	4.80	6.00	0.250	3.440	0.515	3.816	1.092	3.34	15.3	-
213	3	15.5	4.70	6.00	0.340	3.340	0.435	4.117	0.942	3.84	12.1	-
214	2, 3	13.5	4.10	6.00	0.240	3.240	0.438	4.102	0.949	3.70	17.1	-
215	1	13.5	4.05	6.00	0.250	2.750	0.483	4.109	0.946	2.85	16.4	-
216	7	13.33	4.08	6.00	0.250	3.000	0.485	3.894	1.053	3.10	15.6	-
217	6	13.33	4.03	6.00	0.270	2.938	0.426	4.223	0.889	3.45	15.6	-
218	4	13.33	4.01	6.00	0.250	3.000	0.469	3.767	1.117	3.20	15.1	-
219	10	13.33	4.00	6.00	0.250	3.375	0.366	4.143	0.929	4.61	16.6	-
220	11	13.33	4.00	6.00	0.250	3.125	0.454	3.851	1.075	3.45	15.4	-
221	9	13.33	4.00	6.00	0.250	2.750	0.469	3.663	1.169	2.93	14.7	-
222	8	13.33	3.96	6.00	0.219	3.469	0.406	3.977	1.012	4.27	18.2	-
223	8	13.6	4.08	5.00	0.480	3.280	0.300	3.573	0.713	5.47	7.4	-
224	7	13.6	4.07	5.00	0.440	3.320	0.325	3.513	0.743	5.11	8.0	-
225	3	13.5	4.05	5.00	0.370	3.050	0.405	3.237	0.882	3.77	8.7	-
226	6	13.33	4.09	5.00	0.438	2.969	0.375	3.373	0.813	3.96	7.7	-
227	10	13.33	4.00	5.00	0.313	3.000	0.439	3.397	0.802	3.42	10.9	-
228	11	13.33	4.00	5.00	0.375	2.938	0.407	3.247	0.876	3.61	8.7	-
229	5	13.33	4.00	5.00	0.410	2.875	0.422	3.247	0.876	3.41	7.9	-
230	4	13.33	3.90	5.00	0.313	3.000	0.454	3.060	0.970	3.31	9.8	-
231	2	13.0	3.90	5.00	0.405	2.910	0.375	3.457	0.772	3.88	8.5	-
232	9	12.0	3.60	5.00	0.300	3.000	0.422	3.457	0.772	3.55	11.5	-
233	3	12.0	3.60	5.00	0.280	2.960	0.405	3.237	0.882	3.65	11.6	-
234	1	12.0	3.60	5.00	0.219	2.375	0.563	3.149	0.926	2.11	14.4	-
235	3	11.5	3.45	5.00	0.320	2.940	0.360	3.457	0.772	4.08	10.8	-
236	6	11.33	3.38	5.00	0.313	2.844	0.375	3.373	0.813	3.79	10.8	-
237	3	10.0	3.00	5.00	0.230	2.850	0.360	3.457	0.772	3.96	15.0	-
238	9	10.0	3.00	5.00	0.250	2.750	0.375	3.519	0.741	3.67	14.1	-
239	5	10.0	3.00	5.00	0.230	2.750	0.344	3.561	0.719	4.00	15.5	-
240	10	10.0	3.00	5.00	0.188	2.750	0.407	3.247	0.876	3.38	17.3	-
241	2	10.0	3.00	5.00	0.225	2.730	0.375	3.457	0.772	3.64	15.4	-
242	4	10.0	2.99	5.00	0.250	2.750	0.375	3.248	0.876	3.67	13.0	-
243	6	10.0	2.94	5.00	0.219	2.750	0.375	3.206	0.897	3.67	14.6	-
244	7	9.9	2.97	5.00	0.220	3.100	0.325	3.513	0.743	4.77	16.0	-
245	8	9.9	2.97	5.00	0.260	3.060	0.300	3.573	0.713	5.10	13.7	-
246	8	12.67	3.95	4.00	0.500	3.000	0.391	2.206	0.897	3.84	4.4	-
247	7	12.33	3.94	4.00	0.313	3.000	0.500	1.706	1.147	3.00	5.5	-
248	5	12.33	3.66	4.00	0.313	3.000	0.469	1.998	1.001	3.20	6.4	-
249	9	11.1	3.33	4.00	0.440	2.820	0.330	2.366	0.817	4.27	5.4	-

Table 2.4.1 Dimensions and Primary Properties -- Wrought Iron Sections 1873-1900

Designation	Mill Ref	Wt. per ft lb	X1 ksi	X2 x 106 (1/ksi) ²	Elastic Properties						Plastic Modulus	
					lx in.4	Sx in.3	rx in.	ly in.4	Sy in.3	ry in.	Zx in.3	Zy in.3
188	2	18.0	5209	196	45.8	13.1	2.91	3.7	2.1	0.83	15.0	3.4
189	3	18.0	5270	203	44.2	12.6	2.86	3.3	1.9	0.78	14.6	3.1
190	7	17.13	5090	223	43.1	12.3	2.89	3.4	1.9	0.82	14.4	3.2
191	8	41.0	12825	6	65.5	21.8	2.30	14.7	5.5	1.09	26.8	12.0
192	6	40.0	13592	5	66.5	22.2	2.29	19.3	7.3	1.23	27.4	12.1
193	5	40.0	12621	6	64.9	21.6	2.34	18.6	7.1	1.25	26.9	11.9
194	8	38.5	11953	8	63.2	21.1	2.34	19.1	7.3	1.28	25.7	11.3
195	8	32.53	10817	13	51.8	17.3	2.30	11.8	4.7	1.09	21.6	8.4
196	8	30.33	9543	19	51.4	17.1	2.38	11.7	4.8	1.14	20.4	7.9
197	6	30.0	8541	31	51.2	17.1	2.38	10.7	4.4	1.09	18.9	7.4
198	5	30.0	9279	22	49.8	16.6	2.39	10.8	4.3	1.11	20.2	7.5
199	8	27.87	10944	15	41.7	13.9	2.25	6.4	3.0	0.88	17.1	5.3
200	7	21.0	10112	22	32.0	10.7	2.22	2.8	1.7	0.66	13.2	3.1
201	7	21.0	10059	23	31.4	10.5	2.21	2.8	1.6	0.66	12.9	3.0
202	8	18.97	7968	52	29.6	9.9	2.28	3.2	1.7	0.74	11.9	3.0
203	8	18.5	6906	65	33.3	11.1	2.46	4.3	2.2	0.88	12.9	3.7
204	2	18.0	6801	96	28.4	9.5	2.30	2.5	1.5	0.68	11.4	2.6
205	3	18.0	6501	95	30.8	10.3	2.39	3.2	1.8	0.76	12.1	3.0
206	7	16.67	7058	79	26.9	9.0	2.31	2.2	1.4	0.65	11.2	2.5
207	6	16.67	5253	225	29.0	9.7	2.41	2.7	1.6	0.74	10.6	2.7
208	9	16.67	6539	87	29.7	9.8	2.43	2.8	1.6	0.75	12.0	2.9
209	10	16.67	5613	169	29.0	9.7	2.42	3.4	2.0	0.82	10.9	2.9
210	11	16.67	6704	96	27.0	9.0	2.33	2.7	1.6	0.73	10.8	2.4
211	4	16.67	6295	101	29.0	9.7	2.43	2.7	1.6	0.75	11.7	2.9
212	3	16.0	5886	126	29.0	9.7	2.46	2.9	1.7	0.77	11.2	2.8
213	3	15.5	5730	169	26.3	8.8	2.37	2.2	1.3	0.69	10.3	2.3
214	2, 3	13.5	5108	235	24.5	8.2	2.46	2.0	1.2	0.70	9.4	2.1
215	1	13.5	5879	168	21.4	7.1	2.30	1.6	1.2	0.63	8.9	1.9
216	7	13.33	5687	154	24.1	8.0	2.43	1.8	1.2	0.66	9.6	2.0
217	6	13.33	4943	290	23.2	7.7	2.40	1.7	1.2	0.65	8.8	1.9
218	4	13.33	5576	170	23.5	7.8	2.42	1.6	1.1	0.64	9.3	1.9
219	10	13.33	4421	426	24.0	8.0	2.45	2.6	1.5	0.80	8.7	2.2
220	11	13.33	5502	172	24.0	8.0	2.44	2.2	1.4	0.74	9.5	2.1
221	9	13.33	5731	178	21.7	7.2	2.33	1.3	0.9	0.56	8.7	1.6
222	8	13.33	4830	275	24.6	8.2	2.47	2.4	1.4	0.77	9.3	2.3
223	8	13.6	7472	74	14.3	5.7	1.87	1.6	1.0	0.62	6.9	1.7
224	7	13.6	7063	88	14.6	5.8	1.89	1.5	0.9	0.60	7.1	1.9
225	3	13.5	6938	82	15.3	6.1	1.94	1.6	1.1	0.63	7.3	1.8
226	6	13.33	7486	68	14.7	5.9	1.90	1.4	1.0	0.59	7.1	1.7
227	10	13.33	6114	119	16.0	6.4	1.99	2.0	1.4	0.71	7.3	2.1
228	11	13.33	6554	91	16.0	6.4	1.94	1.8	1.2	0.66	7.1	1.7
229	5	13.33	7463	61	15.1	6.0	1.95	1.5	1.0	0.60	7.3	1.8
230	4	13.33	7040	69	15.4	6.2	1.99	1.7	1.1	0.66	7.5	2.0
231	2	13.0	6998	86	14.2	5.7	1.91	1.3	0.9	0.59	6.9	1.6
232	9	12.0	6036	118	14.9	6.0	2.04	1.7	1.2	0.70	7.1	1.9
233	3	12.0	6062	123	14.4	5.8	2.00	1.5	1.0	0.64	6.7	1.7
234	1	12.0	9417	34	11.0	4.4	1.75	0.8	0.7	0.47	6.8	1.6
235	3	11.5	5943	146	13.4	5.4	1.97	1.3	0.9	0.61	6.4	1.5
236	6	11.33	6055	132	13.4	5.3	1.99	1.2	0.9	0.60	6.3	1.5
237	3	10.0	5156	225	12.5	5.0	2.04	1.2	0.8	0.62	5.8	1.4
238	9	10.0	5345	195	12.4	5.0	2.03	1.1	0.8	0.61	5.9	1.4
239	5	10.0	4665	329	12.7	5.1	2.06	1.2	0.8	0.62	5.5	1.3
240	10	10.0	5863	143	12.0	4.8	2.00	1.4	1.0	0.68	5.9	1.4
241	2	10.0	5276	209	12.3	4.9	2.03	1.1	0.8	0.60	5.7	1.3
242	4	10.0	5771	151	12.1	4.8	2.01	1.0	0.8	0.59	5.9	1.4
243	6	10.0	5374	182	12.5	5.0	2.06	1.1	0.8	0.60	5.7	1.3
244	7	9.9	4707	323	12.5	5.0	2.05	1.4	0.9	0.68	5.7	1.5
245	8	9.9	4612	354	12.5	5.0	2.05	1.2	0.8	0.64	5.6	1.3
246	8	12.67	10451	17	9.0	4.6	1.51	1.6	1.1	0.63	5.5	1.8
247	7	12.33	10287	16	9.2	4.6	1.58	1.7	1.2	0.69	5.9	2.0
248	5	12.33	9324	21	9.2	4.6	1.59	1.7	1.2	0.69	5.7	2.0
249	9	11.1	9255	29	7.6	3.8	1.51	0.9	0.7	0.52	4.6	1.4

Table 2.4.1 Dimensions and Primary Properties -- Wrought Iron Sections 1873-1900

Designation	Mill Ref	Wt. per ft lb	Area	Depth	Web Thickness	Flange Width	Average Flange Thickness	Distance	Distance	Compact Section Criteria		
			A in.2	D in.	tw in.	bf in.	tf in.	T in.	k in.	bf/2tf	h/tw	Fy" ksi
250	4	11.0	3.30	4.00	0.355	2.855	0.375	2.397	0.802	3.81	6.8	-
251	7	10.0	3.09	4.00	0.300	2.625	0.407	2.247	0.876	3.23	7.5	-
252	10	10.0	3.00	4.00	0.250	2.750	0.407	2.435	0.783	3.38	9.7	-
253	2	10.0	3.00	4.00	0.380	2.630	0.328	2.581	0.710	4.01	6.8	-
254	11	10.0	3.00	4.00	0.438	2.500	0.284	2.707	0.647	4.40	6.2	-
255	12	10.0	3.00	4.00	0.422	2.438	0.344	2.497	0.751	3.54	5.9	-
256	5	10.0	2.91	4.00	0.250	2.750	0.375	2.248	0.876	3.67	9.0	-
257	4	9.6	2.90	4.00	0.250	2.750	0.375	2.397	0.802	3.67	9.6	-
258	8	9.33	2.90	4.00	0.250	2.750	0.391	2.373	0.813	3.52	9.5	-
259	3	9.0	2.70	4.00	0.330	2.650	0.300	2.637	0.682	4.42	8.0	-
260	1	9.0	2.70	4.00	0.250	2.500	0.361	2.553	0.724	3.46	10.2	-
261	9	8.2	2.46	4.00	0.320	2.460	0.275	2.673	0.663	4.47	8.4	-
262	9	8.2	2.45	4.00	0.220	2.600	0.330	2.533	0.733	3.94	11.5	-
263	2	8.0	2.40	4.00	0.230	2.460	0.328	2.581	0.710	3.75	11.2	-
264	11	8.0	2.40	4.00	0.313	2.250	0.276	2.723	0.639	4.08	8.7	-
265	12	8.0	2.40	4.00	0.313	2.250	0.344	2.497	0.751	3.27	8.0	-
266	8	7.2	2.23	4.00	0.250	2.328	0.297	2.623	0.688	3.92	10.5	-
267	3	7.0	2.10	4.00	0.180	2.500	0.300	2.637	0.682	4.17	14.7	-
268	8	6.2	1.90	4.00	0.172	2.250	0.297	2.623	0.688	3.79	15.3	-
269	9	6.1	1.82	4.00	0.160	2.300	0.275	2.673	0.663	4.18	16.7	-
270	7	6.0	1.94	4.00	0.150	2.188	0.329	2.497	0.751	3.33	16.6	-
271	12	6.0	1.80	4.00	0.188	2.125	0.329	2.497	0.751	3.23	13.3	-
272	11	6.0	1.80	4.00	0.188	2.125	0.251	2.773	0.614	4.23	14.8	-
273	10	6.0	1.80	4.00	0.200	2.000	0.282	2.707	0.647	3.55	13.5	-
274	3	6.0	1.80	4.00	0.180	2.180	0.251	2.773	0.614	4.34	15.4	-
275	6	6.0	1.77	4.00	0.188	2.000	0.282	2.707	0.647	3.55	14.4	-
276	3	11.0	3.35	3.00	0.460	2.810	0.405	1.337	0.832	3.47	2.9	-
277	4	9.53	2.86	3.00	0.438	2.688	0.344	1.497	0.751	3.91	3.4	-
278	3	9.5	2.90	3.00	0.310	2.660	0.405	1.337	0.832	3.28	4.3	-
279	2	9.0	2.70	3.00	0.400	2.580	0.345	1.517	0.742	3.74	3.8	-
280	1	9.0	2.70	3.00	0.390	2.520	0.360	1.519	0.741	3.50	3.9	-
281	32	9.0	2.65	3.00	0.370	2.560	0.345	1.517	0.742	3.71	4.1	-
282	5	8.9	2.67	3.00	0.440	2.620	0.310	1.573	0.713	4.23	3.6	-
283	6	8.0	2.46	3.00	0.453	2.406	0.282	1.623	0.688	4.27	3.6	-
284	4	7.67	2.25	3.00	0.250	2.500	0.344	1.497	0.751	3.63	6.0	-
285	3	7.25	2.23	3.00	0.335	2.375	0.285	1.697	0.652	4.17	5.1	-
286	3	7.25	2.20	3.00	0.220	2.410	0.345	1.517	0.742	3.49	6.9	-
287	4	7.23	2.21	3.00	0.313	2.406	0.305	1.561	0.719	3.95	5.0	-
288	1	7.0	2.10	3.00	0.190	2.320	0.360	1.519	0.741	3.23	8.0	-
289	5	6.8	2.04	3.00	0.320	2.360	0.265	1.774	0.613	4.45	5.5	-
290	5	6.7	2.01	3.00	0.220	2.400	0.311	1.573	0.713	3.86	7.2	-
291	6	6.67	2.03	3.00	0.313	2.250	0.282	1.623	0.688	4.00	5.2	-
292	4	5.67	1.71	3.00	0.156	2.250	0.305	1.561	0.719	3.69	10.0	-
293	2	5.5	1.70	3.00	0.160	2.220	0.285	1.697	0.652	3.89	10.6	-
294	6	5.33	1.72	3.00	0.188	2.125	0.297	1.623	0.688	3.58	8.6	-
295	5	5.2	1.56	3.00	0.160	2.200	0.265	1.774	0.613	4.15	11.1	-

Table 2.4.1 Dimensions and Primary Properties -- Wrought Iron Sections 1873-1900

Designation	Mill Ref	Wt. per ft lb	X1 ksi	X2 x 106 (1/ksi) ²	Elastic Properties						Plastic Modulus	
					lx in.4	Sx in.3	rx in.	ly in.4	Sy in.3	ry in.	Zx in.3	Zy in.3
250	4	11.0	8115	42	8.1	4.0	1.56	1.2	0.9	0.61	4.8	1.5
251	7	10.0	8147	40	7.6	3.8	1.59	1.1	0.8	0.60	4.6	1.3
252	10	10.0	7592	49	7.6	3.8	1.59	1.1	0.8	0.61	4.6	1.4
253	2	10.0	8010	49	7.0	3.5	1.53	0.9	0.7	0.54	4.2	1.2
254	11	10.0	7980	51	7.0	3.5	1.53	0.8	0.7	0.53	3.9	1.1
255	12	10.0	8840	33	7.0	3.5	1.50	0.8	0.7	0.52	4.2	1.1
256	5	10.0	7230	59	7.5	3.8	1.61	1.1	0.8	0.62	4.4	1.3
257	4	9.6	7131	64	7.5	3.7	1.61	1.0	0.8	0.60	4.4	1.3
258	8	9.33	7125	59	7.7	3.9	1.63	1.2	0.9	0.63	4.5	1.4
259	3	9.0	7046	79	6.5	3.3	1.55	0.8	0.6	0.54	3.9	1.0
260	1	9.0	6334	100	7.0	3.5	1.61	1.0	0.8	0.61	4.0	1.2
261	9	8.2	6819	95	5.8	2.9	1.53	0.5	0.4	0.46	3.5	0.9
262	9	8.2	6108	115	6.4	3.2	1.62	0.8	0.7	0.59	3.8	1.1
263	2	8.0	6126	118	6.2	3.1	1.61	0.7	0.6	0.55	3.6	0.9
264	11	8.0	5597	158	6.5	3.3	1.66	0.6	0.5	0.50	3.2	0.8
265	12	8.0	7919	51	5.6	2.8	1.53	0.6	0.5	0.51	3.7	0.9
266	8	7.2	6102	130	5.6	2.8	1.58	0.6	0.5	0.50	3.3	0.8
267	3	7.0	5224	197	5.7	2.9	1.65	0.7	0.5	0.57	3.3	0.9
268	8	6.2	5269	199	5.1	2.6	1.65	0.5	0.4	0.51	3.0	0.7
269	9	6.1	4893	269	4.9	2.5	1.65	0.5	0.4	0.52	2.8	0.7
270	7	6.0	5803	141	5.1	2.6	1.68	0.5	0.4	0.50	3.0	0.7
271	12	6.0	6698	92	4.4	2.2	1.56	0.4	0.4	0.47	3.1	0.7
272	11	6.0	5390	276	4.0	2.0	1.50	0.4	0.4	0.48	2.6	0.6
273	10	6.0	5533	200	4.4	2.2	1.56	0.3	0.3	0.42	2.7	0.5
274	3	6.0	4641	380	4.6	2.3	1.61	0.4	0.3	0.45	2.6	0.6
275	6	6.0	5267	228	4.5	2.3	1.59	0.3	0.3	0.42	2.6	0.5
276	3	11.0	13497	6	4.2	2.8	1.13	1.3	0.9	0.62	3.5	1.6
277	4	9.53	11987	9	3.7	2.5	1.14	1.0	0.8	0.59	3.0	1.3
278	3	9.5	11279	11	3.9	2.6	1.17	1.1	0.8	0.81	3.1	1.3
279	2	9.0	11194	12	3.5	2.4	1.15	0.9	0.7	0.56	2.9	1.1
280	1	9.0	11414	11	3.5	2.4	1.15	0.8	0.7	0.56	2.9	1.1
281	32	9.0	11078	13	3.4	2.3	1.14	0.8	0.7	0.56	2.8	1.1
282	5	8.9	11675	11	3.4	2.3	1.13	0.6	0.5	0.49	2.8	1.1
283	6	8.0	12143	10	3.1	2.0	1.11	0.6	0.5	0.49	2.5	0.9
284	4	7.67	9013	23	3.3	2.2	1.21	0.8	0.6	0.59	2.6	1.0
285	3	7.25	9232	26	3.0	2.0	1.15	0.6	0.5	0.50	2.3	0.8
286	3	7.25	8812	26	3.1	2.1	1.20	1.0	0.8	0.46	2.5	0.9
287	4	7.23	9412	23	3.0	2.0	1.17	0.6	0.5	0.53	2.4	0.9
288	1	7.0	8702	26	3.1	2.1	1.21	0.6	0.5	0.55	2.4	0.9
289	5	6.8	8754	33	2.7	1.8	1.15	0.4	0.4	0.46	2.2	0.7
290	5	6.7	8138	36	2.9	2.0	1.21	0.6	0.5	0.53	2.3	0.9
291	6	6.67	8814	29	2.8	1.9	1.18	0.5	0.4	0.48	2.2	0.7
292	4	5.67	7273	50	2.7	1.8	1.25	0.5	0.4	0.53	2.1	0.7
293	2	5.5	6835	69	2.5	1.7	1.24	0.4	0.4	0.52	1.9	0.7
294	6	5.33	7530	49	2.5	1.7	1.21	0.4	0.4	0.49	2.0	0.6
295	5	5.2	6405	89	2.4	1.6	1.23	0.4	0.4	0.51	1.8	0.6

Table 2.4.2 Torsion Properties -- Wrought Iron Sections 1873-1900

Designation	Torsional Constant	Warping Constant	(ECw/GJ) ^{1/2}	Normalized Warping Constant	Warping Statical Moment	Statical Moment	Statical Moment
	J	Cw		a	Wno	Sw	Qf
	in.4	in.6	in.	in.2	in.4	in.3	in.3
1	10.66	4128	31.7	31.8	62.1	33.0	100
2	10.07	4626	34.5	33.1	63.7	33.0	98.5
3	4.64	2505	37.4	29.9	40.2	23.7	72.3
4	4.94	2418	35.6	28.6	40.2	24.6	74.1
5	12.52	2001	20.3	21.5	39.6	21.8	68.9
6	9.58	1983	23.2	20.5	31.9	18.5	61.6
7	10.20	1247	17.8	20.4	33.5	19.4	63.4
8	10.57	1851	21.3	21.0	37.8	21.8	64.9
9	9.93	1459	19.5	20.3	30.4	17.6	61.3
10	10.86	1378	18.1	19.3	32.0	19.2	63.8
11	9.83	1644	20.8	21.0	32.4	18.3	62.2
12	9.38	1615	21.1	20.8	32.1	18.3	61.3
13	6.86	1282	22.0	19.8	27.2	16.6	54.9
14	6.73	1239	21.8	19.4	27.7	17.6	54.0
15	6.18	1092	21.4	19.4	23.4	14.5	51.8
16	7.08	1010	19.2	17.3	25.1	17.6	52.8
17	7.24	1339	21.9	19.7	30.4	19.1	56.6
18	7.03	1349	22.3	20.1	32.1	20.0	57.2
19	4.77	1678	30.2	19.6	24.7	15.8	49.1
20	5.58	1512	26.5	19.6	28.5	18.0	53.6
21	7.14	1152	20.4	18.6	28.2	18.4	55.2
22	6.88	1390	22.9	20.1	29.8	18.3	55.1
23	4.64	1015	23.8	19.0	19.0	12.2	46.0
24	6.34	1366	23.6	19.9	29.1	18.3	53.4
25	6.10	1341	23.9	19.8	28.8	18.3	52.5
26	4.06	1011	25.4	21.6	19.5	11.2	45.3
27	5.09	1132	24.0	19.1	25.3	16.6	49.2
28	4.12	941	24.3	18.4	20.1	13.6	45.0
29	3.54	736	23.2	17.9	19.9	14.3	43.1
30	3.66	780	23.5	17.9	20.2	14.6	43.5
31	3.23	776	24.9	17.9	19.1	13.6	41.1
32	2.43	827	29.7	17.9	16.9	12.2	37.6
33	2.66	879	29.2	17.8	17.2	12.4	38.8
34	2.69	927	29.9	17.8	17.4	12.6	38.4
35	3.18	679	23.5	16.8	17.4	13.1	40.3
36	3.12	614	22.6	15.9	15.5	12.3	38.6
37	3.29	843	25.8	18.1	20.3	14.5	41.3
38	1.71	608	30.3	18.1	15.2	11.2	34.3
39	1.64	675	32.7	17.5	14.0	10.4	33.2
40	1.88	522	26.8	16.5	14.0	11.0	33.8
41	1.48	793	37.3	20.2	17.0	11.3	33.9
42	7.42	827	17.0	15.8	21.9	12.9	41.6
43	5.77	554	15.8	14.6	16.8	10.7	36.9
44	5.80	488	14.8	14.3	14.2	9.05	35.4
45	7.07	402	12.1	12.1	16.9	12.7	37.8
46	5.79	658	17.2	14.7	19.9	13.3	38.9
47	5.74	724	18.1	15.1	21.4	13.9	38.4
48	3.87	770	22.7	15.1	15.8	10.3	32.9
49	4.34	685	20.2	14.9	16.1	10.4	34.3
50	5.12	817	20.3	15.6	20.8	13.5	38.3
51	4.94	538	16.8	14.4	16.2	10.7	35.4

Table 2.4.2 Torsion Properties -- Wrought Iron Sections 1873-1900

Designation	Torsional Constant	Warping Constant	$(EC_w/GJ)^{1/2}$	Normalized Warping Constant	Warping Statical Moment	Statical Moment	Statical Moment
	J	Cw		a	Wno	Sw	Qf
	in.4	in.6	in.	in.2	in.4	in.3	in.3
52	5.43	705	18.3	15.2	20.2	12.9	37.7
53	4.43	504	17.2	14.5	14.4	9.43	33.5
54	4.26	412	15.8	13.8	13.3	9.01	32.6
55	2.01	376	22.0	15.3	10.4	6.80	25.9
56	2.39	346	19.4	13.0	11.8	9.05	27.3
57	2.38	346	19.4	13.0	11.7	9.01	27.2
58	2.60	234	15.2	11.1	10.1	8.85	26.7
59	2.68	397	19.6	13.5	13.6	10.3	29.3
60	2.16	460	23.5	13.7	12.3	9.05	27.1
61	2.55	406	20.3	13.3	12.8	9.68	28.2
62	1.99	423	23.4	13.2	11.4	8.71	26.4
63	2.46	379	20.0	13.7	12.9	9.68	28.2
64	2.27	385	21.0	13.5	12.5	9.43	27.0
65	2.30	527	24.4	13.3	12.4	9.47	26.7
66	1.18	286	25.0	12.7	7.9	6.43	20.8
67	1.15	247	23.5	12.8	8.79	7.16	21.1
68	0.78	297	31.5	14.4	9.12	6.80	19.8
69	4.54	513	17.1	13.2	16.2	10.2	30.4
70	3.77	368	15.9	12.0	14.0	10.0	27.4
71	3.38	413	17.8	12.0	13.4	9.56	26.4
72	3.84	382	16.0	12.0	14.0	10.1	27.1
73	2.94	442	19.7	12.0	13.3	9.54	26.0
74	2.88	275	15.7	12.1	11.0	7.63	24.8
75	2.92	261	15.2	12.1	9.34	6.37	23.6
76	2.79	352	18.1	12.5	11.8	8.01	25.1
77	3.75	360	15.8	11.9	14.2	10.3	27.1
78	3.26	439	18.7	12.6	14.7	10.2	26.9
79	2.19	286	18.4	11.7	10.3	7.63	22.8
80	1.63	234	19.3	11.6	8.68	6.57	20.5
81	1.82	297	20.6	11.9	10.65	8.01	21.6
82	2.13	217	16.2	10.9	10.0	8.05	21.8
83	1.52	212	19.0	11.5	8.31	6.37	19.8
84	1.66	217	18.4	11.0	8.72	7.00	20.1
85	1.38	237	21.1	11.0	7.62	6.09	19.1
86	1.88	228	17.7	10.7	8.41	6.81	20.5
87	1.93	223	17.3	10.9	9.61	7.83	20.8
88	1.22	195	20.3	11.2	7.95	6.37	18.4
89	1.40	191	18.8	10.7	8.24	6.95	18.6
90	1.20	185	20.0	10.8	7.56	6.32	17.8
91	0.94	173	21.8	10.3	5.87	5.09	16.2
92	1.34	178	18.5	10.1	7.02	6.14	17.9
93	1.37	195	19.2	11.0	8.54	7.06	18.4
94	1.13	203	21.6	11.1	8.00	6.57	17.9
95	4.40	336	14.1	11.4	12.7	8.66	26.6
96	3.42	280	14.6	11.2	10.7	7.43	24.2
97	3.16	243	14.1	11.1	9.49	6.67	23.0
98	3.13	285	15.4	10.8	11.5	8.66	23.6
99	2.56	239	15.6	10.7	9.72	7.30	22.0
100	1.95	179	15.4	9.59	6.97	5.73	19.3
101	2.22	226	16.2	10.7	9.63	7.43	21.1
102	2.01	213	16.6	10.4	9.10	7.30	20.1

Table 2.4.2 Torsion Properties -- Wrought Iron Sections 1873-1900

Designation	Torsional Constant	Warping Constant	$(EC_w/GJ)^{1/2}$	Normalized Warping Constant	Warping Statical Moment	Statical Moment	Statical Moment
	J	C _w		a	W _{no}	S _w	Q _f
	in.4	in.6	in.	in.2	in.4	in.3	in.3
103	1.81	205	17.2	10.5	8.56	6.72	19.7
104	1.74	240	18.9	10.8	8.56	6.60	19.5
105	1.69	183	16.7	10.4	7.83	6.20	18.9
106	0.97	142	19.5	9.13	5.06	4.55	15.4
107	1.41	174	17.9	10.2	7.98	6.72	17.7
108	1.38	171	17.9	10.0	7.78	6.67	17.3
109	1.12	184	20.6	10.3	6.68	5.50	16.5
110	1.28	162	18.1	10.0	7.31	6.20	17.0
111	5.21	368	13.5	10.7	14.8	9.81	25.7
112	4.76	263	12.0	10.4	10.8	7.00	23.2
113	4.89	277	12.1	10.3	11.5	7.55	23.6
114	3.62	235	13.0	10.1	10.1	6.97	21.5
115	2.92	185	12.8	9.13	9.12	7.08	19.9
116	3.39	181	11.8	9.03	9.85	7.65	21.1
117	2.86	191	13.2	9.79	8.12	5.79	19.2
118	2.58	216	14.7	10.7	8.50	5.69	19.0
119	2.83	212	13.9	9.57	9.86	7.55	19.8
120	2.32	154	13.1	9.33	6.89	5.17	17.6
121	1.57	125	14.4	9.07	6.13	4.91	15.7
122	1.28	170	18.5	9.94	7.39	5.69	15.5
123	1.51	145	15.8	9.07	6.98	5.79	15.7
124	1.00	135	18.6	9.47	4.92	3.87	13.4
125	1.47	143	15.9	9.14	6.41	5.19	15.4
126	1.14	139	17.8	8.55	3.88	3.27	12.9
127	1.23	119	15.8	9.11	5.70	4.66	14.4
128	1.08	122	17.1	9.39	5.61	4.49	14.0
129	1.22	118	15.9	8.67	5.95	5.17	14.4
130	1.39	109	14.2	8.02	5.59	5.16	14.5
131	1.28	128	16.1	9.39	6.93	5.65	15.1
132	0.92	136	19.6	8.97	5.31	4.48	13.4
133	1.35	132	16.0	8.86	6.18	5.22	14.9
134	1.01	97.8	15.8	8.37	5.30	4.80	13.4
135	1.05	94.7	15.3	8.67	4.99	4.28	13.5
136	1.47	108	13.8	8.28	5.95	5.36	14.8
137	0.70	105	19.7	8.99	5.15	4.49	12.1
138	0.74	82.6	17.0	8.36	4.63	4.28	12.0
139	0.84	96.1	17.2	8.40	5.26	4.91	12.4
140	0.99	61.3	12.7	7.27	4.38	4.55	12.3
141	0.52	104	22.6	8.83	4.02	3.55	10.9
142	0.89	95.2	16.7	8.42	4.87	4.42	12.6
143	0.82	86.9	16.6	8.41	4.99	4.62	12.3
144	0.56	97.7	21.2	8.05	3.13	2.95	10.3
145	0.80	63.5	14.3	7.33	4.01	4.17	11.5
146	0.80	99.1	17.9	8.69	5.18	4.66	12.3
147	0.60	62.5	16.5	7.39	3.56	3.72	10.5
148	3.00	155	11.6	8.54	7.82	5.60	17.0
149	2.36	132	12.0	8.49	6.45	4.67	15.3
150	2.17	95.4	10.7	7.94	5.06	3.85	14.0
151	2.08	131	12.7	8.13	7.09	5.60	15.2
152	1.57	95.1	12.5	7.78	5.45	4.46	13.4
153	1.15	97.5	14.8	7.80	5.44	4.67	12.3

Table 2.4.2 Torsion Properties -- Wrought Iron Sections 1873-1900

Designation	Torsional Constant	Warping Constant	$(EC_w/GJ)^{1/2}$	Normalized Warping Constant	Warping Statical Moment	Statical Moment	Statical Moment
	J	C _w		a	W _{no}	S _w	Q _f
	in.4	in.6	in.	in.2	in.4	in.3	in.3
154	1.14	105	15.4	8.30	5.83	4.75	12.5
155	1.18	84.9	13.6	7.51	5.06	4.46	12.2
156	1.02	77.0	14.0	7.08	2.97	2.64	10.3
157	1.40	92.8	13.1	7.51	5.57	4.91	12.8
158	1.10	103	15.6	8.31	5.70	4.65	12.3
159	1.10	91.3	14.6	7.73	4.52	3.83	11.7
160	0.96	78.3	14.6	7.67	4.45	3.86	11.2
161	0.88	57.8	13.1	7.15	3.85	3.52	10.7
162	0.74	62.7	14.8	7.05	3.99	3.85	10.2
163	0.74	69.6	15.6	7.44	4.18	3.86	10.2
164	0.74	69.4	15.6	7.44	4.18	3.86	10.2
165	0.74	63.9	15.0	7.47	3.97	3.59	10.2
166	0.83	79.9	15.8	7.41	4.40	4.05	10.6
167	0.76	80.3	16.6	7.44	4.19	3.86	10.2
168	0.66	63.2	15.7	7.45	4.08	3.77	9.94
169	0.65	54.7	14.7	6.90	3.58	3.52	9.68
170	0.58	55.4	15.7	6.28	2.95	3.11	9.22
171	1.66	58.9	9.60	6.65	3.75	2.98	10.6
172	1.60	58.3	9.71	6.67	3.66	2.90	10.4
173	1.00	53.2	11.7	6.34	3.63	3.20	9.52
174	0.98	50.5	11.5	6.29	3.46	3.06	9.37
175	0.97	55.1	12.1	6.38	3.98	3.61	9.52
176	0.77	47.2	12.6	6.13	3.40	3.20	8.73
177	0.77	43.2	12.1	6.15	3.21	2.98	8.64
178	0.75	42.8	12.2	5.75	2.80	2.74	8.26
179	0.61	49.5	14.6	5.77	2.71	2.67	8.01
180	0.66	36.5	12.0	5.89	2.93	2.87	8.12
181	0.66	32.8	11.4	5.65	2.70	2.74	7.92
182	0.50	33.0	13.1	5.50	2.21	2.28	7.24
183	0.45	32.3	13.6	5.69	2.45	2.50	7.30
184	0.51	41.2	14.5	6.09	2.86	2.81	7.45
185	0.65	33.9	11.6	5.63	2.77	2.85	7.85
186	0.61	36.4	12.4	5.53	2.68	2.82	7.64
187	0.43	40.6	15.7	5.59	2.38	2.52	6.95
188	0.54	38.5	13.6	5.81	2.95	3.06	7.53
189	0.51	34.2	13.2	5.68	2.72	2.87	7.33
190	0.48	35.9	14.0	5.84	2.80	2.90	7.23
191	3.98	97.7	7.97	6.93	7.86	5.03	13.4
192	4.47	125	8.50	6.69	7.95	5.19	13.8
193	3.93	121	8.92	6.69	7.95	5.34	13.5
194	3.43	127	9.80	6.77	7.50	5.03	12.9
195	2.23	83.2	9.83	6.64	5.71	3.99	10.8
196	1.85	82.7	10.7	6.47	5.43	3.99	10.2
197	1.47	78.3	11.7	6.59	4.73	3.43	9.43
198	1.70	77.0	10.8	6.68	5.48	3.95	10.1
199	1.75	48.1	8.42	5.90	3.38	2.59	8.55
200	1.11	21.4	7.05	4.64	1.96	1.89	6.60
201	1.08	21.1	7.11	4.65	1.90	1.84	6.49
202	0.68	24.6	9.66	5.24	2.00	1.85	5.94
203	0.67	32.3	11.2	5.26	2.68	2.59	6.44
204	0.48	19.4	10.2	4.81	1.82	1.83	5.72

Table 2.4.2 Torsion Properties -- Wrought Iron Sections 1873-1900

Designation	Torsional Constant	Warping Constant	$(EC_w/GJ)^{1/2}$	Normalized Warping Constant	Warping Statical Moment	Statical Moment	Statical Moment
	J	C _w		a	W _{no}	S _w	Q _f
	in.4	in.6	in.	in.2	in.4	in.3	in.3
205	0.51	23.8	10.9	4.85	2.21	2.25	6.08
206	0.50	16.3	9.21	4.34	1.71	1.89	5.61
207	0.32	21.4	13.1	4.89	1.74	1.77	5.29
208	0.51	20.9	10.2	4.78	2.23	2.32	6.03
209	0.37	26.0	13.5	4.76	1.90	2.01	5.43
210	0.45	20.4	10.8	4.55	1.69	1.81	5.44
211	0.47	20.6	10.6	4.80	2.16	2.26	5.87
212	0.42	21.6	11.5	4.72	2.09	2.25	5.63
213	0.33	17.1	11.5	4.65	1.69	1.82	5.16
214	0.26	15.5	12.3	4.51	1.60	1.83	4.73
215	0.27	12.2	10.8	3.79	1.26	1.67	4.46
216	0.32	13.7	10.5	4.14	1.50	1.84	4.80
217	0.23	13.1	12.3	4.09	1.28	1.58	4.38
218	0.30	12.3	10.4	4.15	1.46	1.78	4.69
219	0.20	20.3	16.4	4.75	1.47	1.61	4.35
220	0.30	17.1	12.1	4.33	1.54	1.81	4.74
221	0.27	9.56	9.61	3.80	1.23	1.62	4.37
222	0.25	18.9	14.1	4.85	1.71	1.85	4.68
223	0.28	8.62	8.97	3.85	0.95	0.99	3.47
224	0.26	8.09	8.99	3.88	1.05	1.09	3.56
225	0.28	8.50	8.90	3.50	1.08	1.25	3.65
226	0.29	7.70	8.23	3.43	0.96	1.10	3.56
227	0.24	10.61	10.7	3.42	1.13	1.35	3.67
228	0.27	9.23	9.33	3.37	1.01	1.20	3.56
229	0.31	7.60	7.90	3.29	1.00	1.19	3.66
230	0.30	8.68	8.64	3.41	1.16	1.39	3.75
231	0.25	7.17	8.55	3.36	0.92	1.09	3.44
232	0.22	9.12	10.3	3.43	1.09	1.30	3.55
233	0.21	7.71	9.65	3.40	1.02	1.25	3.37
234	0.30	3.89	5.82	2.63	0.88	1.35	3.38
235	0.18	6.84	9.82	3.41	0.90	1.09	3.19
236	0.19	6.47	9.37	3.29	0.88	1.10	3.17
237	0.14	6.19	10.8	3.31	0.85	1.09	2.91
238	0.15	5.94	10.2	3.18	0.82	1.08	2.95
239	0.12	6.23	11.8	3.20	0.76	1.01	2.73
240	0.16	7.33	10.7	3.16	0.88	1.20	2.98
241	0.14	5.78	10.3	3.16	0.81	1.09	2.88
242	0.16	5.56	9.40	3.18	0.82	1.08	2.95
243	0.15	5.83	9.93	3.18	0.82	1.10	2.88
244	0.12	7.43	12.9	3.62	0.91	1.09	2.88
245	0.11	6.74	12.5	3.60	0.83	0.99	2.79
246	0.36	5.18	6.11	2.71	0.79	0.88	2.76
247	0.35	5.33	6.24	2.63	0.98	1.18	2.98
248	0.31	5.42	6.69	2.65	0.93	1.11	2.85
249	0.23	3.10	5.88	2.59	0.60	0.72	2.32
250	0.20	3.98	7.13	2.59	0.69	0.85	2.41
251	0.19	3.45	6.80	2.36	0.63	0.85	2.30
252	0.17	3.65	7.35	2.47	0.69	0.91	2.33
253	0.16	2.93	6.82	2.41	0.52	0.68	2.11
254	0.16	2.87	6.76	2.32	0.41	0.54	1.96
255	0.20	2.74	5.97	2.23	0.47	0.63	2.11

Table 2.4.2 Torsion Properties -- Wrought Iron Sections 1873-1900

Designation	Torsional Constant	Warping Constant	$(EC_w/GJ)^{1/2}$	Normalized Warping Constant	Warping Statical Moment	Statical Moment	Statical Moment
	J	C _w		a	W _{no}	S _w	Q _f
	in.4	in.6	in.	in.2	in.4	in.3	in.3
256	0.16	3.65	7.74	2.49	0.64	0.85	2.20
257	0.15	3.42	7.69	2.49	0.64	0.85	2.20
258	0.16	3.81	7.81	2.48	0.67	0.88	2.26
259	0.12	2.70	7.60	2.45	0.49	0.64	1.95
260	0.11	3.31	8.69	2.27	0.51	0.74	1.98
261	0.10	1.84	6.95	2.29	0.39	0.55	1.74
262	0.10	2.83	8.62	2.39	0.51	0.72	1.88
263	0.09	2.39	8.13	2.26	0.46	0.67	1.80
264	0.09	2.05	7.85	2.09	0.33	0.50	1.62
265	0.13	1.94	6.27	2.06	0.40	0.61	1.84
266	0.08	1.92	7.86	2.16	0.37	0.57	1.64
267	0.07	2.29	9.33	2.31	0.43	0.64	1.65
268	0.06	1.68	8.50	2.08	0.35	0.57	1.49
269	0.05	1.70	9.38	2.14	0.34	0.55	1.42
270	0.07	1.52	7.47	2.01	0.36	0.61	1.53
271	0.08	1.35	6.81	1.95	0.34	0.58	1.54
272	0.04	1.48	9.74	1.99	0.27	0.46	1.29
273	0.05	1.07	7.32	1.86	0.26	0.47	1.34
274	0.04	1.26	9.11	2.04	0.28	0.47	1.30
275	0.05	1.07	7.49	1.86	0.26	0.47	1.32
276	0.27	2.14	4.51	1.82	0.52	0.62	1.75
277	0.19	1.78	4.89	1.78	0.41	0.51	1.52
278	0.19	1.78	5.00	1.73	0.46	0.62	1.58
279	0.17	1.50	4.82	1.71	0.38	0.50	1.45
280	0.17	1.46	4.76	1.66	0.38	0.51	1.45
281	0.15	1.46	5.00	1.70	0.38	0.50	1.42
282	0.17	1.14	4.20	1.76	0.36	0.45	1.40
283	0.15	1.09	4.28	1.64	0.28	0.37	1.26
284	0.11	1.36	5.71	1.66	0.36	0.51	1.31
285	0.09	1.03	5.35	1.61	0.27	0.39	1.17
286	0.10	1.76	6.85	1.60	0.33	0.50	1.25
287	0.10	1.11	5.33	1.62	0.30	0.43	1.21
288	0.10	0.96	5.10	1.53	0.32	0.51	1.22
289	0.08	0.80	5.18	1.61	0.25	0.37	1.10
290	0.08	1.03	5.84	1.61	0.30	0.46	1.16
291	0.09	0.87	5.13	1.53	0.24	0.37	1.09
292	0.06	0.87	6.11	1.52	0.26	0.43	1.03
293	0.05	0.81	6.51	1.51	0.24	0.40	0.98
294	0.06	0.77	5.85	1.44	0.23	0.39	0.99
295	0.04	0.75	6.88	1.50	0.22	0.37	0.92

2.4.3 Beams - Wrought Iron

Depth	Reference	20	15	12	10 1/2	10	9	8	7	6	5	4	3
	Mill Year	Mill Year	Mill Year	Mill Year	Mill Year	Mill Year	Mill Year	Mill Year	Mill Year	Mill Year	Mill Year	Mill Year	Mill Year
1	NJ 1885 NJ 1885 NJ 1891	CK 1873	CK 1873	CK 1873	CK 1873	CK 1873	CK 1873	CK 1873	CK 1873	CK 1873	CK 1873	CK 1873	CK 1873 CK 1884
2	PH 1888 CB 1884	CB 1884	CB 1884	CB 1884	CB 1884	CB 1884	CB 1884	CB 1881 CB 1884	CB 1881 CB 1884	CB 1884	CB 1881 CB 1884	CB 1881 CB 1884	CP 1889 CP 1890 CP 1892
3		CP 1889 CP 1890 CP 1892	CP 1889 CP 1890 CP 1892	CP 1889 CP 1890 CP 1892	CP 1889 CP 1890 CP 1892	CP 1889 CP 1890 CP 1892	CP 1889 CP 1890 CP 1892	CP 1889 CP 1890 CP 1892	CP 1889 CP 1890 CP 1892	CP 1889 CP 1890 CP 1892	CP 1889 CP 1890 CP 1892	CP 1889 CP 1890 CP 1892	CP 1892 CP 1892
4		NJ 1874 NJ 1885 NJ 1889 NJ 1891	NJ 1874 NJ 1885 NJ 1889 NJ 1891	NJ 1874 NJ 1885 NJ 1889 NJ 1891	PE 1887 NJ 1874	PE 1887 NJ 1874	NJ 1874 NJ 1885 NJ 1889 NJ 1891	NJ 1874 NJ 1885 NJ 1889 NJ 1891	NJ 1874 NJ 1885 NJ 1889 NJ 1891	NJ 1874 NJ 1885 NJ 1889 NJ 1891	NJ 1874 NJ 1885 NJ 1889 NJ 1891	CP 1892 CP 1892	PE 1887
5		NJ 1889 NJ 1891	PA 1884 NJ 1889 NJ 1891	PA 1884 NJ 1889 NJ 1891	NJ 1885 NJ 1889 NJ 1891	PO 1887 NJ 1885 NJ 1889 NJ 1891	NJ 1885 NJ 1889 NJ 1891	PA 1884 NJ 1885 NJ 1889 NJ 1891	NJ 1885 NJ 1889 NJ 1891	NJ 1885 NJ 1889 NJ 1891	PA 1884 NJ 1885 NJ 1889 NJ 1891	NJ 1874 NJ 1885 NJ 1889 NJ 1891	PE 1888 PE 1889 PE 1891
6		PA 1884	PE 1887 PE 1888	PE 1887 PE 1888	PA 1884	PA 1884	PA 1884	PE 1887 PE 1888 PE 1891	PA 1884	PA 1884	PE 1887	NJ 1885 NJ 1889 NJ 1891	PO 1887
7		PE 1887 PE 1888	PE 1891	PE 1891	PE 1887		PE 1887 PE 1888 PE 1889	PH 1885 PH 1890	PE 1887 PE 1888 PE 1891	PE 1887	PE 1888 PE 1889	PA 1884	
8		PE 1888 PE 1889 PE 1891	PH 1885	PH 1885	PE 1888 PE 1889		PE 1891	PO 1885 PO 1887	PH 1885 PH 1888 PH 1890	PH 1885 PH 1888 PH 1889	PE 1891	PE 1887	
9		PE 1891	PH 1888 PH 1890	PH 1888 PH 1890	PH 1885 PH 1888		PH 1885 PH 1888 PH 1890	PO 1887	PO 1885 PH 1885 PH 1888 PH 1890	PH 1885 PH 1888 PH 1889	PH 1885 PH 1890	PE 1888 PE 1889	
10		PH 1885 PH 1888 PH 1890	PO 1885	PO 1885	PO 1885		PO 1885	PO 1885	PO 1887	PO 1885	PO 1885	PH 1885 PH 1888 PH 1889	PH 1885 PH 1888 PH 1890
11		PH 1888 PH 1890	PO 1887	PO 1887	PO 1887		PO 1887	PO 1887	PO 1887	PO 1888	PO 1887	PO 1885	PO 1885
12		PO 1885										PO 1887	
13		PO 1887											

Chapter 3

EVALUATION OF EXISTING STRUCTURES

3.1 Introduction

Evaluation of structures for potential rehabilitation can be required for many reasons. Some of the more common are as follows:

- Change in building use.
- General renovation or upgrade.
- Expansion, either vertical or horizontal.
- Deterioration of members, such as in old timber structures.
- Damage from fire or explosion.
- Historic preservation.
- Verification of design loadings or code requirements.
- Rehab or build-new decisions.
- Seismic damage.
- Change in seismic code requirements.

Regardless of the reasons, evaluation must proceed in a carefully organized manner appropriate to the situation. Although load testing may be required in some cases, evaluation will usually rely on a structural analysis of the existing structure. As indicated in Section 3.3, all dimensions used in the evaluation (spans, column heights, member spacings, bracing locations, cross section dimensions, thicknesses, connection details, etc.) should be determined from a field survey. Dimensions can also be obtained from project plans or drawings, where available, with field verification of critical values. The design strength of members and connections can then be determined from the provisions of the *Specification*.

3.2 Evaluation Methods

As suggested above, the first step in planning rehabilitation work is a careful evaluation of the existing structure. Fortunately, several references are available to help organize this process for both gravity loads and seismic loads as indicated below. Methods of structural enhancement and rehab are reviewed in Section 4.

3.2.1 Gravity Loads

Evaluation of the strength and stiffness of existing structures under vertical static loads (i.e.

gravity loads) are treated in the 1999 AISC LRFD *Specification*, Chapter N, “Evaluation of Existing Structures.” Evaluation by structural analysis and/or load tests is included. Material property considerations are also treated. Chapter N and its Commentary are reproduced below in Section 3.3.

Pertinent information is also provided in AWS D1.1, particularly Chapter 8, “Strengthening and Repairing Existing Structures.” (See 5.2.1: AWS, 1996.) Subjects covered include suitability of the base metal for welding, design for strengthening and repair (design process, stress analysis, fatigue history, restoration or replacement, loading during operations, existing connections, and use of existing fasteners), fatigue life enhancement, workmanship and technique, and quality.

3.2.2 Seismic Loads

For seismic rehabilitation, reference should be made to the publications of FEMA. The FEMA publications provide an excellent source of material for understanding many important aspects of building rehabilitation, particularly as related to seismic damage. The information provided therein has been used to update the AISC *Seismic Provisions for Structural Steel Buildings* and the building codes.

A summary of each of the following FEMA references is provided in Section 5.2.3:

Federal Emergency Management Agency (FEMA), *Interim Guidelines: Evaluation, Repair, Modification and Design of Welded Steel Moment Frame Structures*, FEMA 267, August 1995; and *Interim Guidelines Advisory No. 2*, FEMA 267B, June 1999.

Federal Energy Management Agency (FEMA), *NEHRP Guidelines for the Seismic Rehabilitation of Buildings*, No. 273, FEMA, Washington, D.C., 1997.

Federal Energy Management Agency (FEMA), *NEHRP Commentary on the Guidelines for the Seismic Rehabilitation*

of Buildings, No. 274, FEMA, Washington, D.C., 1997.

Federal Energy Management Agency (FEMA), *Recommended Seismic Design Criteria for New Moment Resisting Steel Frames*, No. 350, FEMA, Washington, D.C., July 2000.

Federal Energy Management Agency (FEMA), *Recommended Seismic Evaluation and Upgrade Criteria for Existing Welded Steel Moment-Resisting Frame Construction*, No. 351, FEMA, Washington, D.C., July 2000.

Federal Energy Management Agency (FEMA), *Recommended Post-Earthquake Evaluation and Repair Criteria for Existing Welded Steel Frame Structures*, No. 352, FEMA, Washington, D.C., July 2000.

Federal Energy Management Agency (FEMA), *Recommended Quality Assurance Guidelines for Moment-Resisting Steel Frame Construction*, No. 353, FEMA, Washington, D.C., July 2000.

Federal Energy Management Agency (FEMA), *Recommended Specifications for Moment-Resisting Steel Frames for Seismic Applications*, No. 354, FEMA, Washington, D.C., July 2000.

Federal Emergency Management Agency (FEMA), *Seismic Evaluation & Upgrade Criteria for Existing Welded Steel Moment-Resisting Frame Structures*, SAC Joint Venture Report No. SAC-2000-02-b, Sacramento, CA, 2000.

3.3 Chapter N, AISC LRFD Specification

3.3.1. Specification Provisions

The following is excerpted from the *AISC Load and Resistance Factor Design Specification for Structural Steel Buildings* (AISC, 1999.)

This chapter applies to the evaluation of the strength and stiffness under static vertical (gravity) loads of existing structures by structural analysis, by load tests, or by a combination of structural analysis and load tests when specified by the Engineer of

Record or in the contract documents. For such evaluation, the steel grades are not limited to those listed in A3.1. This chapter does not address load testing for the effects of seismic loads or moving loads (vibrations).

N1. GENERAL PROVISIONS

These provisions shall be applicable when the evaluation of an existing steel structure is specified for (a.) verification of a specific set of design loadings or (b.) determination of the design strength of a load resisting member or system. The evaluation shall be performed by structural analysis (Section N3), by load tests (Section N4), or by a combination of structural analysis and load tests, as specified in the contract documents. Where load tests are used, the Engineer of Record shall first analyze the structure, prepare a testing plan, and develop a written procedure to prevent excessive permanent deformation or catastrophic collapse during testing.

N2. MATERIAL PROPERTIES

1. Determination of Required Tests

The Engineer of Record shall determine the specific tests that are required from Section N2.2 through N2.6 and specify the locations where they are required. Where available, the use of applicable project records shall be permitted to reduce or eliminate the need for testing.

2. Tensile Properties

Tensile properties of members shall be considered in evaluation by structural analysis (Section N3) or load tests (Section N4). Such properties shall include the yield stress, tensile strength, and percent elongation. Where available, certified mill test reports or certified reports of tests made by the fabricator or a testing laboratory in accordance with ASTM A6/A6M or A568/A568M, as applicable, shall be permitted for this purpose. Otherwise, tensile tests shall be conducted in accordance with ASTM A370 from samples cut from components of the structure.

3. Chemical Composition

Where welding is anticipated for repair or modification of existing structures, the chemical composition of the steel shall be determined for use in preparing a welding procedure specification (WPS). Where available, results from certified mill test reports or certified reports of tests made by the fabricator or a testing laboratory in accordance with ASTM procedures shall be permitted for this purpose. Otherwise, analyses shall be conducted in accordance with ASTM A751 from the samples used to determine tensile properties, or from samples taken from the same locations.

4. Base Metal Notch Toughness

Where welded tension splices in heavy shapes and plates as defined in Section A3.1c are critical to the performance of the structure, the Charpy V-notch toughness shall be determined in accordance with the provisions of Section A3.1c. If the notch toughness so determined does not meet the provisions of A3.1c, the Engineer of Record shall determine if remedial actions are required.

5. Weld Metal

Where structural performance is dependent on existing welded connections, representative samples of filler metal shall be obtained. Chemical analyses and mechanical tests shall be made to characterize the filler metal. A determination shall be made of the magnitude and consequences of imperfections. If the requirements of AWS D1.1 are not met, the Engineer of Record shall determine if remedial actions are required.

6. Bolts and Rivets

Representative samples of bolts shall be inspected to determine markings and classifications. Where bolts can not be properly identified visually, representative samples shall be removed and tested to determine tensile strength in accordance with ASTM F606 or ASTM F606M and the bolt classified accordingly. Alternatively, the assumption that the bolts are A307 shall be permitted. Rivets shall be assumed to be A502, Grade 1, unless a higher grade is

established through documentation or testing.

N3. EVALUATION BY STRUCTURAL ANALYSIS

1. Dimensional Data

All dimensions used in the evaluation, such as spans, column heights, member spacings, bracing locations, cross section dimensions, thicknesses, and connection details, shall be determined from a field survey. Alternatively, when available, it shall be permitted to determine such dimensions from applicable project plans or drawings with field verification of critical values.

2. Strength Evaluation

Forces (load effects) in members and connections shall be determined by structural analysis applicable to the type of structure evaluated. The load effects shall be determined for the loads and load combinations stipulated in Section A4.

The design strength of members and connections shall be determined from applicable provisions of Chapters B through K of this *Specification*.

3. Serviceability Evaluation

Where required, the deformations at service loads shall be calculated and reported.

N4. Evaluation by Load Tests

1. Procedure for Determination of Live Load Rating by Testing

To determine the live load rating of an existing floor or roof structure by testing, a test load shall be applied incrementally in accordance with the Engineer of Record's plan. The structure shall be visually inspected for signs of distress or imminent failure at each load level. Appropriate measures shall be taken if these or any other unusual conditions are encountered.

The tested design strength of the structure shall be taken as the maximum applied test load plus the in-situ dead load. The live load rating of a floor structure shall be determined by setting the tested design

strength equal to $1.2D + 1.6L$, where D is the nominal dead load and L is the nominal live load rating for the structure. The nominal live load rating of the floor structure shall not exceed that which can be calculated using applicable provisions of the *Specification*. For roof structures, L_r , S , or R as defined in the Symbols, shall be substituted for L . More severe load combinations shall be used where required by applicable building codes.

Periodic unloading shall be considered once the service load level is attained and after the onset of inelastic structural behavior is identified to document the amount of permanent set and the magnitude of the inelastic deformations. Deformations of the structure, such as member deflections, shall be monitored at critical locations during the test, referenced to the initial position before loading. It shall be demonstrated, while maintaining maximum test load for one hour, that the deformation of the structure does not increase by more than 10 percent above that at the beginning of the holding period. It is permissible to repeat the sequence if necessary to demonstrate compliance.

Deformations of the structure shall also be recorded 24 hours after the test loading is removed to determine the amount of permanent set. Because the amount of acceptable permanent deformation depends on the specific structure, no limit is specified for permanent deformation at maximum loading. Where it is not feasible to load test the entire structure, a segment or zone of not less than one complete bay, representative of the most critical conditions, shall be selected.

2. Serviceability Evaluation

When load tests are prescribed, the structure shall be loaded incrementally to the service load level. Deformations shall be monitored for a period of one hour. The structure shall then be unloaded and the deformation recorded.

N5. EVALUATION REPORT

After the evaluation of an existing structure has been completed, the Engineer of Record shall prepare a report documenting the

evaluation. The report shall indicate whether the evaluation was performed by structural analysis, by load testing or by a combination of structural analysis and load testing. Furthermore, when testing is performed, the report shall include the loads and load combination used and the load-deformation and time-deformation relationships observed. All relevant information obtained from design drawings, mill test reports, and auxiliary material testing shall also be reported. Finally, the report shall indicate whether the design strength of the structure, including all members and connections, is adequate to withstand the load effects.

3.3.2. Commentary

The following is excerpted from the Commentary on the AISC *Load and Resistance Factor Design Specification for Structural Steel Buildings* (AISC, 1999).

N1. GENERAL PROVISIONS

The load combinations referred to in this chapter reflect gravity loading because it is the most prevalent condition encountered. If other loading conditions are a consideration, such as lateral loads, the appropriate load combination from ASCE 7 (ASCE, 1998) or from the applicable building code should be used. Guidelines for seismic evaluation are available in other publications (FEMA, 1997a and FEMA, 1997b). The Engineer of Record for a project is generally established by the owner.

N2. MATERIAL PROPERTIES

1. Determination of Required Tests

The extent of tests required depends on the nature of the project, the criticality of the structural system or member evaluated, and the availability of records pertinent to the project. Thus, the Engineer of Record is required to determine the specific tests required and the locations from which specimens are to be obtained.

2. Tensile Properties

Samples required for tensile tests should be removed from regions of reduced stress, such as at flange tips at beam ends and

external plate edges, to minimize the effects of the reduced area. The number of tests required will depend on whether they are conducted to merely confirm the strength of a known material or they are conducted to establish the strength of some other steel. Guidance on the appropriate minimum number of tests is available (FEMA, 1997a).

It should be recognized that the yield stress determined by standard ASTM methods and reported by mills and testing laboratories is somewhat greater than the *static* yield stress because of dynamic effects of testing. Also, the test specimen location may have an effect. These effects have already been accounted for in the nominal strength equations in the *Specification*. However, when strength evaluation is done by load testing, this effect should be accounted for in test planning because yielding will tend to occur earlier than otherwise anticipated. The static yield stress, F_{ys} , can be estimated from that determined by routine application of ASTM methods, F_y , by the following equation (Galambos, 1978 and 1998):

$$F_{ys} = R(F_y - 4) \quad (\text{C-N2-1})$$

where

- F_{ys} = static yield stress, ksi (MPa)
- F_y = reported yield stress, ksi (MPa)
- R = 1.00 for tests taken from flange specimens
- R = 0.95 for tests taken from web specimens

The R factor in Equation C-N2-1 accounts for the effect of the coupon location on the reported yield stress. Prior to 1997, certified mill test reports for structural shapes were based on specimens removed from the web, in accordance with ASTM A6/A6M. Subsequently the specified coupon location was changed to the flange. During 1997-1998, there was a transition from web specimens to flange specimens as the new provisions of ASTM A6/ A6M were adopted.

4. Base Metal Notch Toughness

The Engineer of Record shall specify the location of samples. Samples shall be cored, flame cut, or saw cut. The Engineer of Record will determine if remedial actions

are required, such as the possible use of bolted splice plates.

5. Weld Metal

Because connections typically have a greater reliability index than structural members, strength testing of weld metal is not usually necessary. However, field investigations have sometimes indicated that complete-joint-penetration welds, such as at beam-to-column connections, were not made in accordance with AWS D1.1 (AWS, 1998). The specified provisions in Section N2.4 provide a means for judging the quality of such a weld. Where feasible, any samples removed should be obtained from compression splices rather than tension splices, because the effects of repairs to restore the sampled area are less critical.

6. Bolts and Rivets

Because connections typically have a greater reliability index than structural members, removal and strength testing of fasteners is not usually necessary. However, strength testing of bolts is required where they cannot be properly identified otherwise. Because removal and testing of rivets is difficult, assuming the lowest rivet strength grade simplifies the investigation.

N3. EVALUATION BY STRUCTURAL ANALYSIS

2. Strength Evaluation

Resistance factors reflect variations in determining strength of members and connections, such as uncertainty in theory and variations in material properties and dimensions. If an investigation of an existing structure indicates that there are variations in material properties or dimensions significantly greater than those anticipated in new construction, the Engineer of Record should consider the use of more conservative values.

N4. EVALUATION BY LOAD TESTS

1. Determination of Live Load Rating by Testing

Generally, structures that can be designed according to the provisions of the

Specification need no confirmation of calculated results by test. However, special situations may arise when it is desirable to confirm by tests the results of calculations. Minimal test procedures are provided to determine the live load rating of a structure. However, in no case is the live load rating determined by test to exceed that which can be calculated using the provisions of the *Specification*. This is not intended to preclude testing to evaluate special conditions or configurations that are not adequately covered by the *Specification*.

It is essential that the Engineer of Record take all necessary precautions to ensure that the structure does not fail catastrophically during testing. A careful assessment of structural conditions before testing is a fundamental requirement. This includes accurate measurement and characterization of the size and strength of members, connections, and details. All safety regulations of OSHA and other pertinent bodies must be strictly adhered to. Shoring and scaffolding should be used as required in the proximity of the test area to mitigate against unexpected circumstances. Deformations must be carefully monitored and structural conditions must be continually evaluated. In some cases it may be desirable to monitor strains as well.

The Engineer of Record must use judgment to determine when deflections are becoming excessive and terminate the tests at a safe level even if the desired loading has not been achieved. Incremental loading is specified so that deformations can be accurately monitored and the performance of the structure carefully observed. Load increments should be small enough initially so that the onset of significant yielding can be determined. The increment can be reduced as the level of inelastic behavior increases, and the behavior at this level carefully evaluated to determine when to safely terminate the test. Periodic unloading after the onset of inelastic behavior will help the Engineer of Record determine when to terminate the test to avoid excessive permanent deformation or catastrophic failure.

It must be recognized that the margin of safety at the maximum load level used in the test may be very small, depending on such

factors as the original design, the purpose of the tests, and the condition of the structure. Thus, it is imperative that all appropriate safety measures be adopted. It is recommended that the maximum live load used for load tests be selected conservatively. It should be noted that experience in testing more than one bay of a structure is limited.

Criteria limiting increases in deformations for a period of one hour have been given to ensure that the structure is stable at the loads evaluated.

A detailed discussion of reliability-based condition assessment of existing structures has been provided by Ellingwood (1996).

2. Serviceability Evaluation

In certain cases serviceability criteria must be determined by load testing. It should be recognized that complete recovery (i.e., return to initial deflected shape) after removal of maximum load is unlikely because of phenomena such as local yielding, slip at the slab interface in composite construction, creep in concrete slabs, localized crushing or deformation at shear connections in slabs, slip in bolted connections, and effects of continuity. Because most structures exhibit some slack when load is first applied, it is appropriate to project the load-deformation curve back to zero load to determine the slack and exclude it from the recorded deformations. Where desirable, the applied load sequence can be repeated to demonstrate that the structure is essentially elastic under service loads and that the permanent set is not detrimental.

N5. Evaluation Report

Extensive evaluation and load testing of existing structures is often performed when appropriate documentation no longer exists or when there is considerable disagreement about the condition of a structure. The resulting evaluation is only effective if well documented, particularly when load testing is involved. Furthermore, as time passes, various interpretations of the results can arise unless all parameters of the structural performance, including material properties, strength, and stiffness, are well documented.

References

American Society of Civil Engineers (ASCE) (1998), *Minimum Design Loads for Buildings and Other Structures*, ASCE7-98, New York, NY.

Ellingwood, B. R. (1996), "Reliability-Based Condition Assessment and LRFD for Existing Structures," *Structural Safety*, Vol. 18, No. 2/3, 1996.

Federal Energy Management Agency (FEMA) (1997a), *NEHRP Guidelines for the Seismic Rehabilitation of Buildings*, No. 273, FEMA, Washington, D.C.

Federal Energy Management Agency (FEMA) (1997b), *NEHRP Commentary on the Guidelines for the Seismic Rehabilitation of Buildings*, No. 274, FEMA, Washington, D.C.

Galambos, T. V. (ed.) (1998), *Guide to Stability Design Criteria for Metal Structures*, Structural Stability Research Council, 5th Edition, John Wiley & Sons, 1998.

Galambos, T. V. and M. K. Ravindra (1978), "Properties of Steel for Use in LRFD," *Journal of the Structural Division*, ASCE, Vol. 104, No. ST9, September 1978.

Chapter 4

ENHANCEMENT OF EXISTING STRUCTURAL SYSTEMS

4.1 Gravity Systems

In building rehabilitation, the structural engineer is often required to increase the strength and stiffness of an existing floor system. Some important general considerations are as follows.

- Carefully assess required design live loads. What were the original design values for floor live loads? Has there been a change in type of occupancy since the original construction? This type of change may result in a change in live load distribution factors such that the design value of the floor live load is less than anticipated. (See 5.2.1: Thornton, 1991. See 5.2.2: Thornton, "Vertical", 1991 and "Thornton, "Vintage", 1991.)
- Evaluate the feasibility of dead load reduction. What is the composition of the existing floor? Many old floor systems were constructed with cinder fills. If the dead load can be reduced by the elimination of such materials, more capacity is left for live loads. Also, old floor slabs in poor condition can be replaced with lightweight concrete to reduce dead load. (See 5.2.2: Lundeen, 1994 and Anon., "Historic", 1992.)
- Use the AISC *LRFD Specification* to determine existing capacity. If the original design followed ASD rules, a re-evaluation under LRFD rules will likely result in a greater capacity, especially when evaluating composite construction. (See 5.2.1: Miller, 1996, Ruddy, 1987. See 5.2.2: Thayer, 1991, Torrelo, 1990.)

4.1.1 Floors

Some general considerations for floor systems are as follows.

- Evaluate the feasibility of intermediate supports. Is the existing clear span needed for the planned usage? If not, it may be less costly to add an intermediate floor

beam and columns than to increase the flexural strength of the floor system.

- Evaluate the feasibility of inserting extra beams, parallel to the existing ones. This option would mainly be considered when a rather large increase in capacity is required. (See 5.2.2: Marquardt, 1999.)

Several methods of structural enhancement are available if it is determined that the strength or stiffness must be increased. Experience will often suggest the most economical approach. In other cases, it may be necessary to make preliminary designs and compare alternatives. Some methods that have been used are as follows.

- Add steel reinforcement. If the bottom flanges of existing steel beams are accessible, cover plates or bars can be welded to them. Alternatively, structural sections (C, WT, or W sections) can be welded to the bottom flanges, particularly if the main desire is to increase stiffness. (See 5.2.1: Miller, 1996, Ruddy, 1987. See 5.2.2: Nelson, 1991.)
- Add steel cables. Cables can be added to steel beams and pre-tensioned to increase capacity. (See 5.2.1: Koesis, 1997.)
- Add shear connectors. Perhaps the original concrete floor was not designed for composite action, or was designed for partial composite action. A hole in the slab above the steel beam can be created by core drilling or other means, shear connectors can be welded on, and the void repaired with concrete. (See 5.2.1: Ricker, 1988. See 5.2.2: Torrelo, 1990.)
- Encase with concrete. Perhaps there is a desire to enclose the existing steel beams to provide fire protection. Under certain conditions, if the enclosure is cast integrally with the slab, natural bond may be assumed. In other cases, it may be

necessary to add shear connectors before encasing the beam. Requirements are set forth in the AISC *Specification*.

4.1.2 Columns

Columns may also have to be reinforced to accommodate greater loads. Generally this can be accomplished by welding on plates or other sections. Numerous examples of column reinforcement can be cited. (See 5.2.2: Anon., "Pacific . . .," 2000; Gordy, 1997; Punch, 1994; Isbell, 1990.)

It is often necessary to make such column reinforcements while they are loaded, although the loading can usually be reduced. Several authors have addressed design considerations for this condition, but a consensus is not evident. Some have contended that the geometry of the reinforcement and the initial load can affect column capacity. (See 5.2.1: Brown, 1988 and Ricker, 1988.) However, a well-known authority has stated that the strength of columns reinforced under load and reinforced under no load is identical. (See 5.2.1: Tall, 1989.) Tide apparently felt that the approaches of Brown and Ricker were overly conservative and did not reflect actual conditions. (See 5.2.1: Tide, 1990.) Tide also offered the following list of items that should be considered as part of the design process:

- Nature of current and future loads, static or cyclic.
- Ratio of in-situ load and original design load.
- Type and condition of steel.
- Possibility of local buckling.
- Effect of member stability on overall system stability.
- Safety factor required during reinforcing operation.

As an alternative to adding plates, columns can also be encased in concrete. Refer to the AISC *LRFD Specification* for the requirements for composite columns.

4.2 Lateral Systems

In rare cases, enhancement of lateral systems has been required in existing buildings because of excessive flexibility under wind loads. However, upgrades of lateral systems are more often required when seeking improved seismic performance. Methods to increase strength and

stiffness, and reduce force and deformation demands at existing connections, include:

- Adding bracing in existing frames.
- Adding additional moment or braced frames.
- Adding shear walls with infills of steel plate, concrete or masonry.
- Reducing building height.

Additional moment frames can be developed by upgrading simple beam-to-column connections to PR or FR connections. This also has the advantage of providing a more dispersed lateral resistance. Frames can also be added to the exterior of the building.

An alternative strategy is to reduce demand on the existing structure by installing devices such as the following: (See 5.2.3: Weissberg, 1991. See 5.2.2, Fierro, 1992.)

- Base isolation devices.
- Supplemental damping devices
- Active control devices.

Enhancement of lateral systems will often require modification to seismic moment connections to provide increased ductility. Methods to accomplish this are discussed in 4.3.3.

Rehabilitation methods for various frame types are suggested by FEMA 273 as discussed in the following paragraphs.

4.2.1 Fully Restrained Moment Frames

The compatibility of new and existing components and/or elements must be checked at displacements consistent with the performance level chosen for design. FEMA 273 offers the following guidelines:

- Add steel braces to one or more bays of each story to form concentric or eccentric braced frames. Braces significantly increase the stiffness of steel frames. Care should be taken when designing the connections between the new braces and the existing frame. The connection should carry the maximum probable brace force, which may be approximated as 1.2 times the expected strength of the brace.
- Add concrete or masonry shear walls or infill walls to one or more bays of each story. This greatly increases the stiffness

and strength of the structure. Do not introduce torsional stress into the system.

- Attach new steel frames to the exterior of the building. This scheme has been used in the past and has been shown to be very effective under certain conditions. Since this will change the distribution of stiffness in the building, the seismic load path must be carefully checked. The connections between the new and existing frames are particularly vulnerable. This approach may be structurally efficient, but it changes the architectural appearance of the building. The advantage is that the rehabilitation may take place without disrupting the use of the building.
- Reinforce the moment-resisting connections to force plastic hinge locations in the beam material away from the joint region. The idea behind this concept is that the stresses in the welded connection will be significantly reduced, thereby reducing the possibility of brittle fractures. This may not be effective if weld material with very low toughness was used in the full-pen connection. Strain hardening at the new hinge location may produce larger stresses at the weld than expected. Also, many fractures during past earthquakes are believed to have occurred at stresses lower than yield. Various methods, such as horizontal cover plates, vertical stiffeners, or haunches, can be employed. Other schemes that result in the removal of beam material may achieve the same purpose. Modification of all moment-resisting connections could significantly increase (or decrease, in the case of material removal) the structure's stiffness; therefore, recalculation of the seismic demands may be required. Modification of selected joints should be done in a rational manner that is justified by analysis.
- Adding damping devices may be a viable rehabilitation measure for FR frames.

4.2.2 Partially Restrained Moment Frames

FEMA 273 defines partially restrained moment frames as those for which deformation of the beam-to-column connections contributes more than 5 percent of the story drift, or those where the strength of the connection is less than the

strength of the weaker of the two members being joined. Rehab measures include adding bracing or adding infills. Connections can be upgraded by replacing rivets with high-strength bolts, adding supplemental welding, and adding stiffening elements.

4.2.3 Concentrically Braced Frames

Concentrically braced frames are those where the working lines of the members intersect at a point, or within the width of the members if accounted for in design. Rehab methods for moment frames may be applicable to these frames as well. Other measures include replacing or modifying braces, increasing the strength of connections, and reinforcing columns or encasing them in concrete.

4.2.4 Eccentrically Braced Frames

Eccentrically braced frames are those where the working lines of the braces do not intersect at the working line of the beam. The distance between the brace working lines, where they intersect the beam working line, is the eccentricity e and the beam segment over that distance is known as the link beam. Beams, columns, and braces can be reinforced as required. The strength of the link beam may be increased by adding cover plates, by adding doubler plates or stiffeners to the web, or by changing the brace configuration.

4.3 Connections

4.3.1 Connection Types

If beams or other members are strengthened, their connections must also be evaluated. When a connection must be strengthened, it is prudent to review and understand its intended design function. For many years connections have been associated with three types of construction defined in the AISC *Specification*. Type 1, commonly designated as rigid-frame or continuous, assumes that end connections of members have sufficient rigidity such that the original angles between members remained virtually unchanged. Thus, they are designed for both moment and shear. Type 2, conventional or simple framing, assumes that the ends of members are connected for shear only and are free to rotate. Type 3, semi-rigid or partially restrained framing, assumes that the connection of members possessed a dependable and known moment capacity, intermediate between Types 1 and 2. It is recognized that Type 2 and Type 3

construction may result in some non-elastic, but self-limiting deformation, particularly at connections. Thus, such connections must have sufficient inelastic rotation capacity to avoid overloading fasteners or welds.

More recently the AISC *LRFD Specifications* has used the terms Type FR (instead of Type 1) and PR (instead of Type 3). When rotational restraint is ignored, the term “simple framing” is used (instead of Type 2). However, It has long been recognized that “simple” framing connections do possess some degree of rotational restraint.

Design requirements of connections are given in the applicable specifications. It is important that the characteristics of the connection match those assumed in the design of the members. In general, in a rehab project, it is wise to keep the same type of connection as in the original design unless another type is specifically called for and has been considered in the design of the members affected.

The various types of connections may be found in diverse forms. Some of the more widespread types are as follows.

Type 1 (FR) Connections. The most common type encountered is a beam-to-column connection in which the beam flanges are field-welded to the column faces. The shear plates are generally shop-welded to the column and field-bolted to the beam. End-plate connections, with the plate extending over at least the full depth of the beam, also fall into this category.

Type 2 (Simple) Connections. There are several types of these connections, but most may be generally classified as either framing or seated connections. In their simplest form, **framing connections** join the webs of beams running at right angles to each other. Examples include double angle, single angle, tee, and shear plate connections. Generally the angles or plates are welded to one member and bolted (or riveted) to the other. An end-plate connection, welded to the end face of one beam (but not extending over the full beam depth) and bolted to another, may also be included in this category. **Seated connections** are often used to connect beams to column webs. They may be in the form of (a.) an unstiffened seat, where the beam rests on an angle attached to the column in the shop, or (b.) a stiffened seat, where a vertical stiffener (one or two angles, or a plate) supports the seat. In both cases, a top angle or web angle must be added to provide stability. End-plate shear connections, in which the end-

plate extends over less than the full depth of the beam, are also classified as simple connections.

Type 3 (PR) Connections. These are usually beam-to-column connections. Particularly in old construction, the beam flanges are joined to the column flanges with bolted (or riveted) angles or T-stubs. The beam web is also joined to the column in this fashion. In more recent construction, the beam flange angles may be replaced with plates, bolted to the beam and welded to the column. Similarly, the web angles may be replaced with a shear plate, field-bolted to the beam web and shop-welded to the column.

4.3.2 Typical Methods of Reinforcement

Although it may be possible to completely remove the original connection material and replace it, it is generally preferable to reinforce the existing connection. This can be accomplished in various ways, depending upon the new design requirements and the existing details. Typical methods that have been used are reviewed below. (See 5.2.1: Ricker, 1988.) Special considerations for seismic moment connections are treated in 4.3.3.

- In all types of riveted and bolted connections, old rivets or common (A307) bolts can be removed and replaced with A325 or A490 bolts. If necessary, the old holes can be reamed and larger diameter bolts inserted. It may not be necessary to remove all of the rivets. A325 and A490 bolts tightened to the requirements for slip-critical connections can be considered to share the load with the rivets. The strength of A307 bolts used in combination with rivets or high-strength bolts should be ignored.
- In all types of riveted and bolted connections, welds can be added around the periphery of the connection material. Existing rivets and high-strength bolts tightened to the requirements for slip-critical connections are permitted to carry the loads present at the time of the alteration, and the welds can be designed for the additional strength needed. The strength of A307 bolts used in combination with welds should be ignored.
- In fillet welded connections, increase the fillet weld size by welding over the

existing weld. Thoroughly clean the existing weld first.

- In moment connections, FR or PR, where riveted or bolted T-stubs are used to join the beam flanges to the column, the tees can be replaced with connector plates, fillet welded to the flanges and groove welded to the column. Use the most current approved weld details and materials for the type of loading involved. (See 5.2.2: Andrews, 1991.)
- In framing connections, the existing angles or shear plate can be extended by welding an additional length to the beam and adding additional bolts (or welds) to the column (Fig. 4.3.2.1). If the angle or plate is only on one side of the beam, one can be added on the other side. If the existing one-side angle is bolted or riveted to the web, weld it to the web before removing the existing fasteners, then replace the fasteners with new high-strength bolts (Fig. 4.3.2.2).
- Alternatively, in framing connections where riveted or bolted angles are used, fillet welds can be added around the edge of the angles, subject to the design limitations discussed above (Fig. 4.3.2.3). Another approach is to add an angle seat under the beam (Fig. 4.3.2.4). (See 5.2.2: Nelson, 1991).
- In seated connections, web framing angles can be added and attached by welding (Fig. 4.3.2.5). A stiffener can be added to strengthen an unstiffened seat (Fig. 4.3.2.6). The beam web must be checked for yielding and crippling.
- Where additional rotational strength or stiffness is needed in simple connections, add additional connection material and/or welding to create a PR connection. For example, if the original connection was a seat angle connection, a top angle and framing angles can be added and attached with fillet welds, and reinforcing welds can be added to the bottom angle (Fig. 4.3.2.7). Similarly, a PR connection can be upgraded to an FR connection. As in all cases, the member design must be compatible with the connection design.

4.3.3 Rehab of Seismic Moment Connections

AISC Design Guide No. 12 provides guidance for the rehabilitation of existing welded steel moment frame buildings to improve their seismic resistance in future earthquakes. Retrofit concepts include a reduced beam section, a welded haunch, and a bolted bracket approach. These modification alternatives resulted from a joint research effort between the National Institute for Science and Technology and AISC. (See 5.2.3: Gross et al, 1999, "Modification of Existing Steel Welded Moment Frame Connections for Seismic Performance," *Design Guide No. 12*, AISC.) Several FEMA publications referenced in 5.2.3 provide additional information.

As stated in Guide No. 12, the seismic design of welded steel moment frames assumes that in a severe earthquake, frame members will be stressed beyond the elastic limit. Such inelastic action is permitted with the assumption that the behavior will be ductile and energy will be dissipated. The deformation demands at connections subjected to seismic loadings are much greater than for other connections, and it is important that the welds and bolts do not fracture prematurely. The beam-to-column moment connections must be designed for the strength of the beam in flexure or the moment corresponding to the joint panel zone shear strength.

As discussed in Section 4.2, force and deformation demands at existing connections can be reduced by providing additional bracing, shear walls, or moment frames. Simple beam-to-column connections can be upgraded to PR connections to provide a more dispersed lateral resistance. Measures such as base isolation, supplemental damping devices, or active control devices can be employed to reduce demands. (See 5.2.3: Weissberg, 1991. See 5.2.2, Fierro, 1992.)

The repair of existing fractured elements is covered in FEMA 267 and 267B. (Federal Emergency Management Agency (FEMA), *Interim Guidelines: Evaluation, Repair, Modification and Design of Welded Steel Moment Frame Structures*, FEMA 267, August 1995; and *Interim Guidelines Advisory No. 2*, FEMA 267B, June 1999.)

The concepts and main elements of the reduced beam section, welded haunch, and bolted bracket approaches are summarized below. For detailed design information, refer to AISC Design Guide No. 12. The use of welded cover plates is noted. An alternative approach, weld metal replacement, is also reviewed, as well

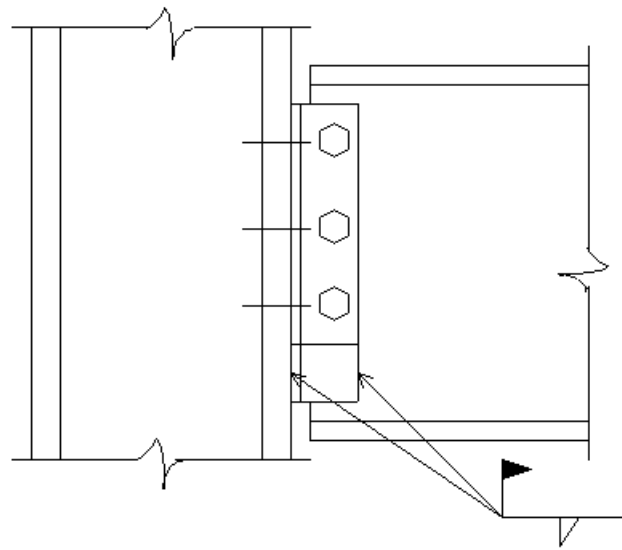

Figure 4.3.2.1 Framing Angle Extension

Rev.
5/1/03

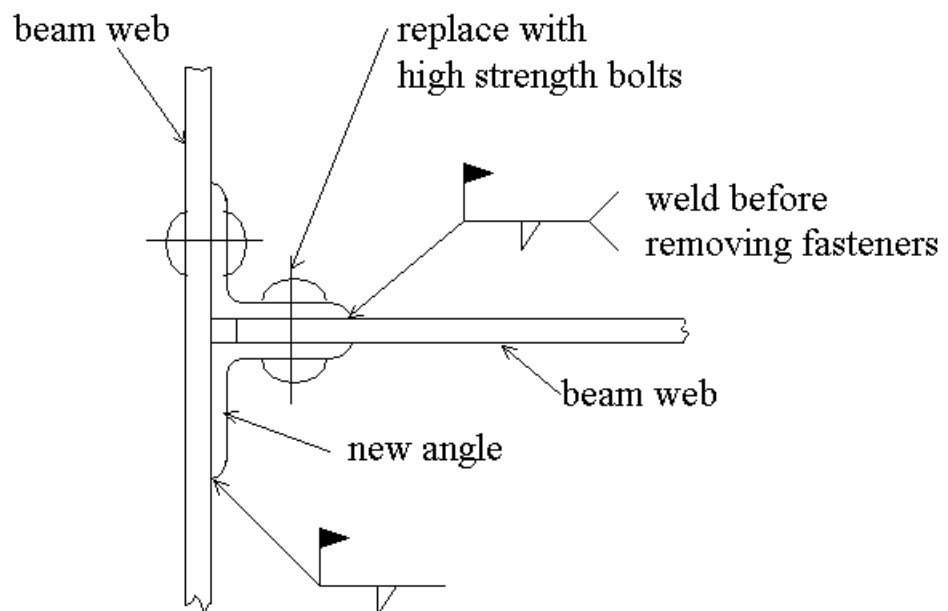

Figure 4.3.2.2 Adding Second Framing Angle

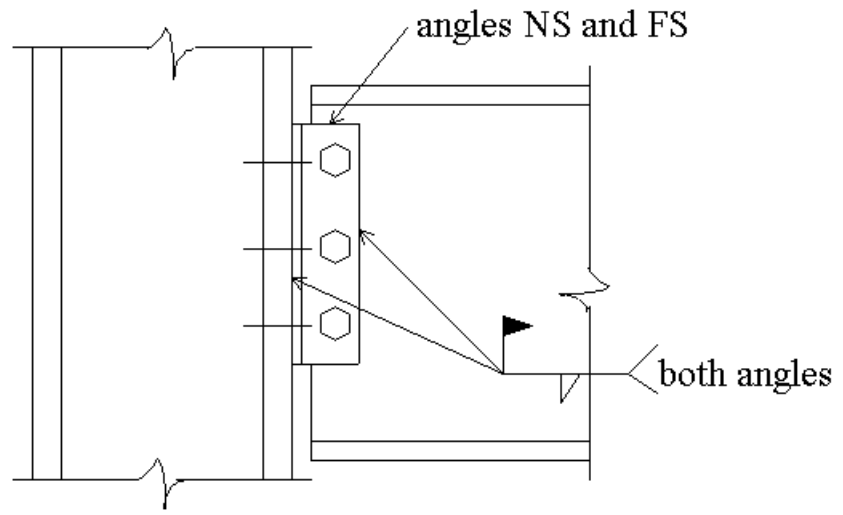

Figure 4.3.2.3 Fillet Weld Reinforcement

Rev.
5/1/03

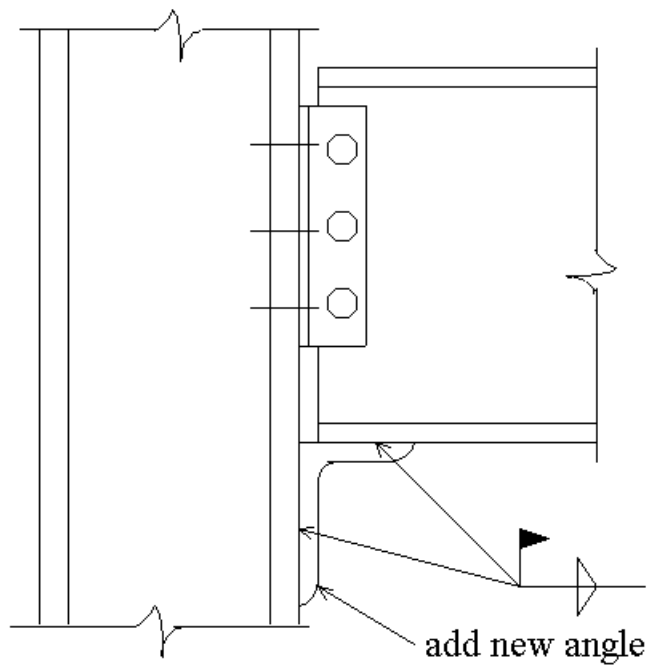

Figure 4.3.2.4 Seat Angle Addition

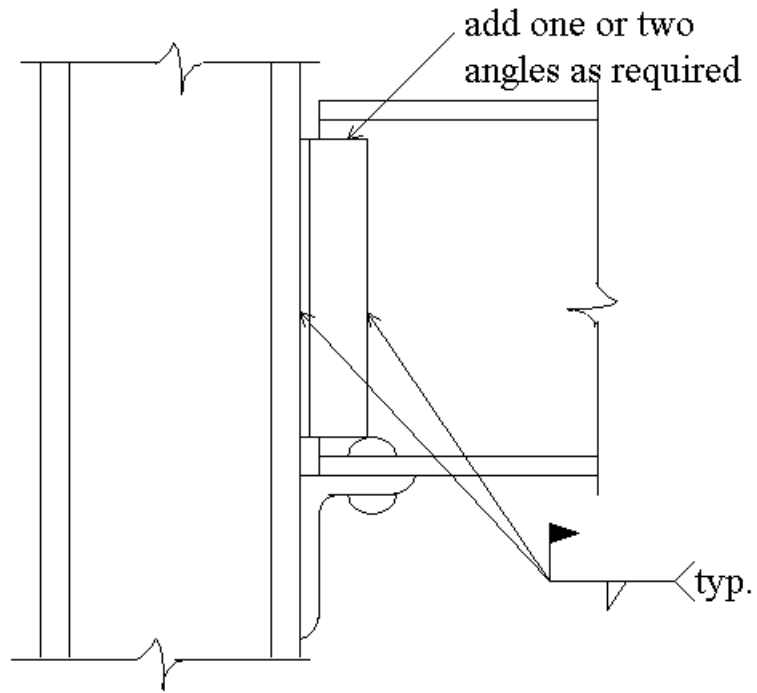

Figure 4.3.2.5 Framing Angle Addition

Rev.
5/1/03

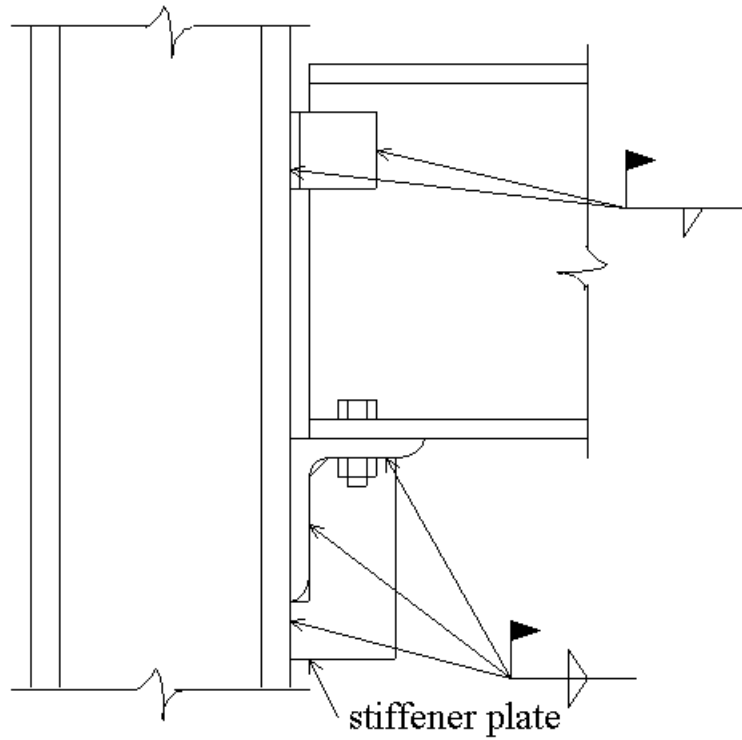

Figure 4.3.2.6 Strengthening an Unstiffened Seat Angle

Rev.
5/1/03

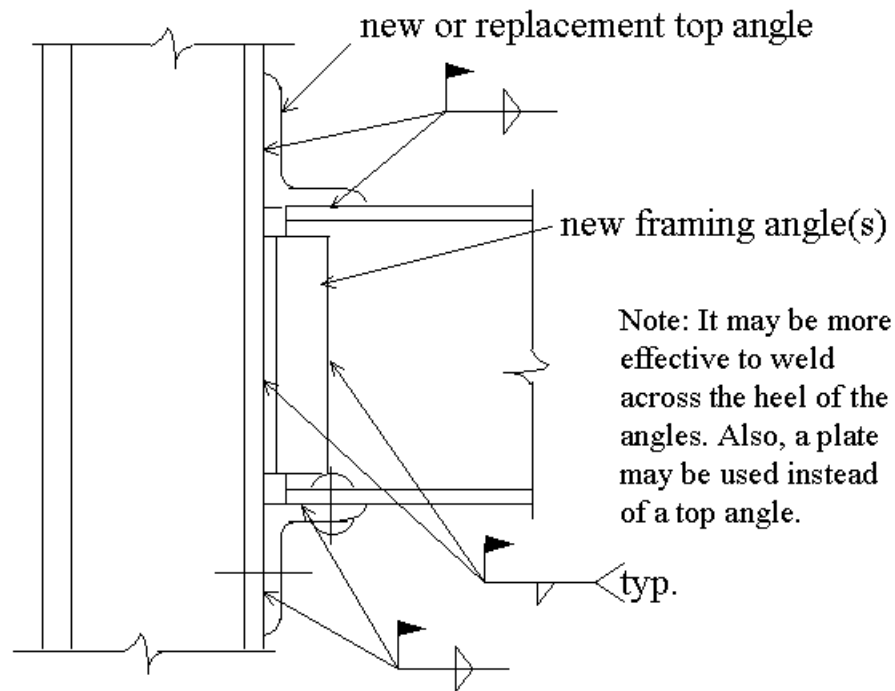

Figure 4.3.2.7 Upgrade of Unstiffened Seated Connection to PR Type

as a promising weld overlay approach. These discussions mostly focus on moment transfer and means for achieving flexural ductility. Beam shears can be transferred by conventional means such as shear plates.

Reduced Beam Section. With the reduced beam section (RBS) scheme, the beam flanges near the column are reduced in cross section, thereby weakening the beam in flexure (Fig. 4.3.3.1). The intent is to force a plastic hinge to form in the reduced section. Thus, the reduced section acts as a structural “fuse” and reduces the demand on the complete joint penetration welds that join the beam flanges to the column. In most cases, the reduction in beam strength is acceptable because drift limitations govern frame design. (See 5.2.3: Zekioglu, 1997.)

Various profiles can be used for the reduced flange section such as a radius cut, tapered cut, or constant width cut (Fig. 4.3.3.2). In new construction, cuts are made in both top and bottom flanges. However, when modifying existing connections, cutting the top flange may prove difficult if a concrete slab is present. AISC Design Guide 12 recommends as a minimum, that the following three modifications be made:

- Provide an RBS cut in the beam bottom flange.
- Replace the existing top and bottom beam flange CJP groove welds with high toughness weld metal.
- Remove the bottom flange steel backing, weld top flange steel backing to face of column, and remove weld tabs at both the top and bottom flange welds. Thus, remove notches that would act as stress risers in areas of high or multi-directional stress.

Welded Haunch. Welding a tapered haunch with a T cross section to the bottom flange has been shown to be very effective for enhancing cyclic performance (Fig. 4.3.3.3). Further improvements could be made by welding haunches to both flanges, but that would require the removal of the floor slab in that area. The addition of the haunch moves the plastic hinge zone away from the column face and reduces demand on the welds to the column face. The haunch acts as a strut and changes the force transfer mechanism. (See 5.2.3: Uang, 1996.)

The haunch can be cut from a W section or welded from plate. The haunch web is fillet welded to the beam and column flanges and the

haunch flanges then groove welded to the column flanges.

FEMA 351 recommends that, for special moment frame (SMF) applications, if the weld of the top flange to the column was made with weld metal with low or unclassified notch toughness, the top flange must be gouged out and replaced with high toughness weld metal. For ordinary moment frame (OMF) applications, this requirement does not apply.

Bolted Bracket. The bolted bracket is an alternative to the welded haunch in which high-strength bolts rather than welds are used to attach the bracket. AISC Design Guide recommends as a minimum modification, attaching a haunch bracket to the bottom flange and a single angle bracket to the bottom flanges. Modification of the CJP groove welds at the top and bottom flanges is not required. Other options include using a haunch bracket for both flanges, or a haunch bracket for the bottom flange and a double angle bracket for the top flange. As with the other reinforcement schemes discussed, the bolted brackets force the inelastic action in the beam outside the reinforced region.

Various details have been developed for the bracket. The *haunch bracket* is fabricated from plate and consists of a vertical stiffener with a shop-welded horizontal and vertical leg; the legs are bolted to the beam and column flanges (Fig. 4.3.3.4). The *angle bracket* is fabricated from a short length of relatively heavy wide flange section by cutting off one of the projecting flanges; the web forms the horizontal leg bolted to the beam and the flange forms the vertical leg bolted to the column (Fig. 4.3.3.5). For light beams, a hot rolled angle may be sufficient instead.

When bolting the bracket from one side of the flange, a horizontal washer plate on the opposite side of the flange enhances ductility (see Fig. 4.3.3.4). Also, a thin brass shim between the bracket and the beam flange helps prevent noise and galling associated with any interface slip that might occur.

Welded Flange Plates. A connection can be upgraded by fillet welding plates to both the top and bottom flanges of the existing beams. The plates must be attached to the columns with CJP welds. FEMA 351 recommends that, for special moment frame (SMF) applications, if the welds to the column were made with weld metal with low or unclassified notch toughness, they must be gouged out and replaced with high toughness

Rev.
5/1/03

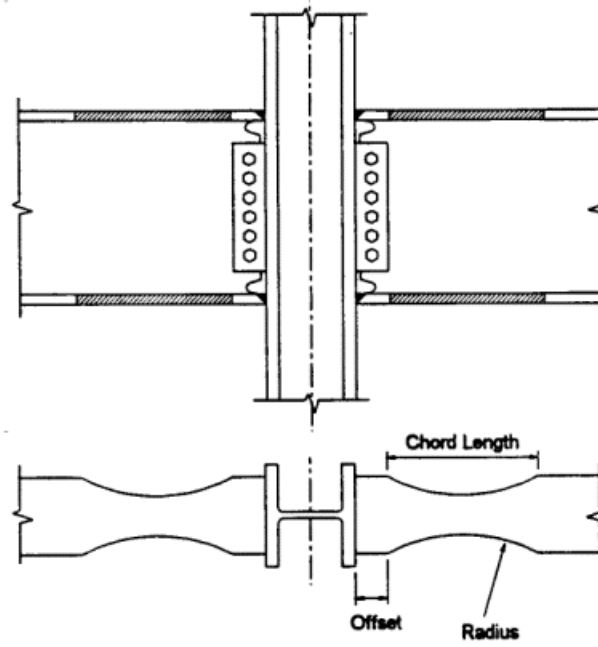

Fig. 4.3.3.1 Reduced Beam Section (RBS) Connection

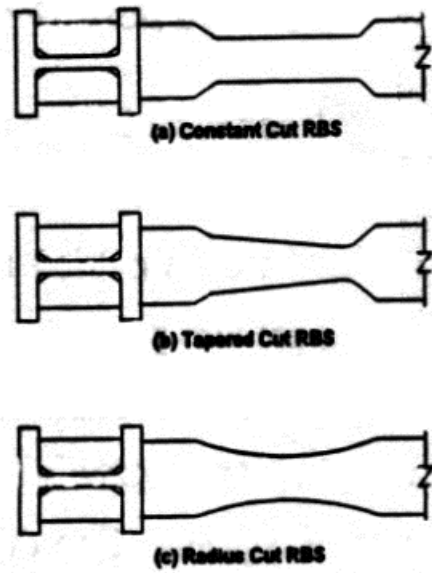

Fig. 4.3.3.2 Contour Detail for RBS Connection

Rev.
5/1/03

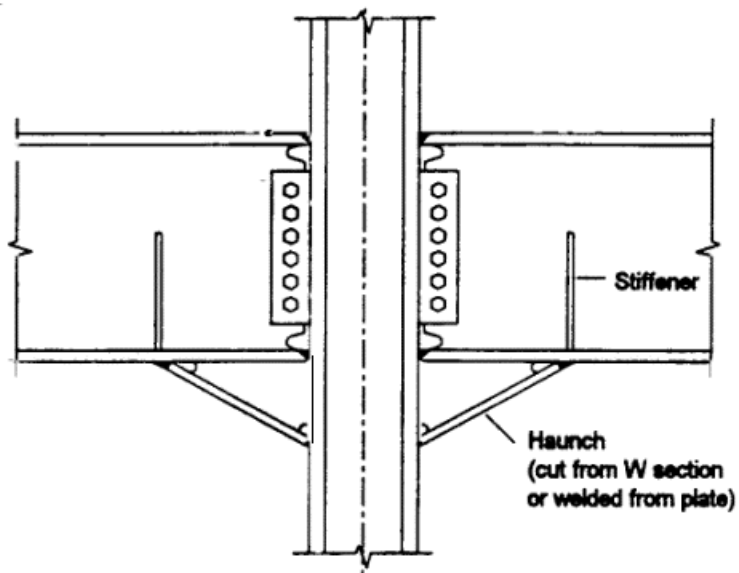

Fig. 4.3.3.3 Welded Haunch Connection

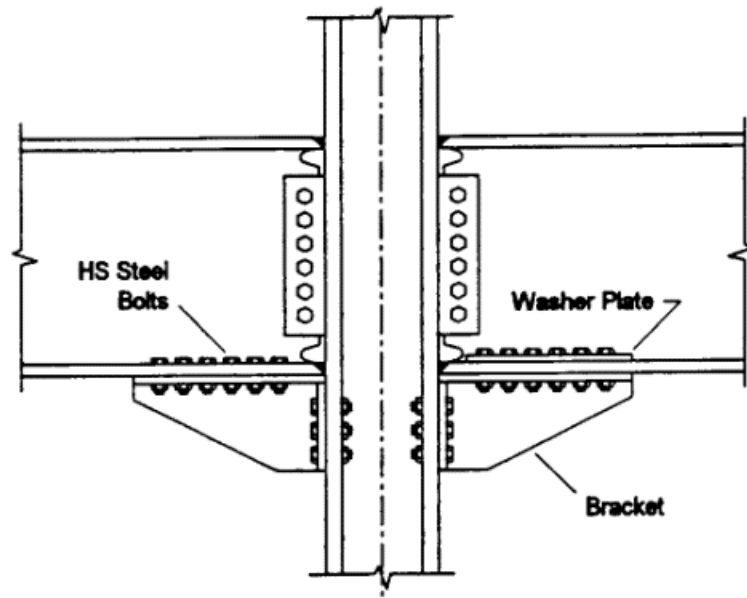

Fig. 4.3.3.4 Bolted Bracket Connection, Haunch Type

Rev.
5/1/03

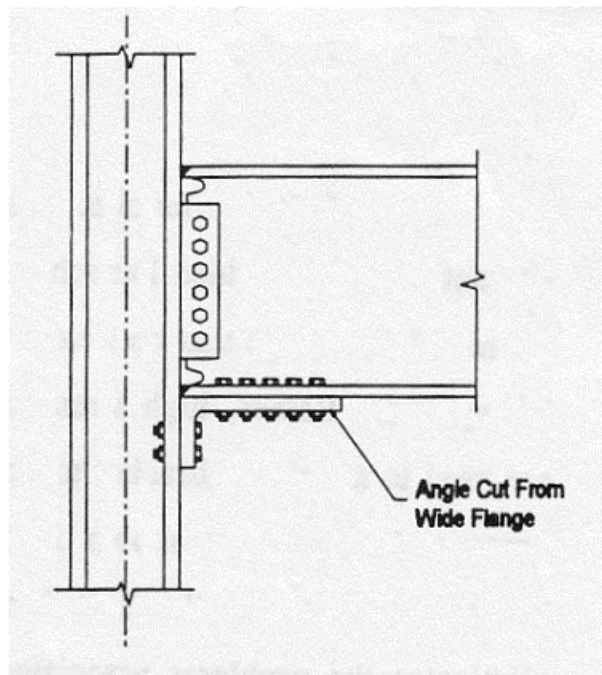

Fig. 4.3.3.5 Bolted Bracket Connection, Angle Type

weld metal. For ordinary moment frame (OMF) applications, this requirement does not apply.

Weld Replacement Approach. Full scale tests conducted at Lehigh University have shown that, in lieu of the three approaches discussed above, ductile behavior can be achieved in welded moment connections by removing existing welds (damaged welds) and re-welding the flanges with tougher electrodes. Improved detailing is also required, such as removing back-up bars and weld tabs. Bolted shear tabs reinforced with fillet welds on three sides behave similar to a fully welded web. The addition of the welds delays web buckling and improves the force transfer mechanism. (See 5.2.3: Xue, 1996.)

Weld Overlay Approach. A separate study has indicated that earthquake-damaged connections can sometimes be restored to their original condition by depositing a higher-grade weld overlay that resists fracture. The DLW Task Group conducted both small and large-scale tests to verify overall elastic and ductile behavior. Additional tests are planned to extend the proposed repair method to retrofit applications. (See 5.2.3: Anon., 1998 and Simon, 1999.)

Proprietary Designs. Some proprietary designs have also been developed and tested. The slotted beam connection described by Richard et al, which was used in a 20-story building, is one example (Fig. 4.3.3.6). (See 5.2.3: Richard, 1998.)

4.4 Welding to Existing Members

Although welding to existing members is commonly done in retrofit projects, it requires careful consideration of numerous factors. A summary of items that must be addressed is presented below. (See 5.2.1: Ricker, 1988.)

Determine Weldability. Where welding is anticipated, the chemical composition should be determined and a welding procedure specification (WPS) established. In some cases it may be possible to identify the steel grade from markings on the members and certified mill test reports may be available. In other cases, samples will have to be taken from the members and laboratory analyses made. The need for preheat and low hydrogen electrodes will depend on the chemical composition and the geometrical restraint of the detail. Reference should be made to AWS D1.1 for guidance in preparing the

WPS. If the material is identified as wrought iron or cast iron, it is advisable to avoid welding.

Select and Design the Weld. Consider the following general principles when planning the welding:

- Fillet welds are usually preferable to groove welds.
- Where there is a choice, make the welds in the flat or horizontal position.
- Avoid cutting across stress lines with the weld where practical.
- Avoid biaxial and triaxial stress conditions near welds.
- Avoid over welding, causing excessive shrinkage and distortion.
- Avoid abrupt geometric discontinuities at welds.
- For groove welds, a joint design with the least weld volume is usually preferable.
- Where appropriate, use partial joint penetration welds instead of complete joint penetration (CJP) groove welds, such as for column splices.
- Where appropriate, use intermittent fillet welds instead of continuous fillet welds, particularly for static loads.
- Use standard weld symbols per AWS D1.1 on drawings.
- Orient welds so contraction strains are imposed on the base metal in a longitudinal direction, to diminish the possibilities of lamellar tearing.
- Matching filler metal as defined by AWS D1.1 is required for CJP welds stressed in tension normal to the weld area. Filler metal with a strength equal to or less than matching is permitted for other welds.
- Avoid arc strikes in highly stressed areas and weld splatter.

Heavy Sections. Special requirements apply to Group 4 and Group 5 rolled shapes, and to plates over 2-in. thick, subjected to primary tensile stress and spliced by welding. Such requirements also apply when CJP welded joints through the thickness are used for connections subjected to primary tensile stress. Supplementary requirements for these conditions as given in AISC *Specifications* involve Charpy V-notch (CVN) impact testing of material, weld access hole geometry, and grinding. These requirements should be followed in rehab work where heavy material subject to tensile stress is encountered.

Rev.
5/1/03

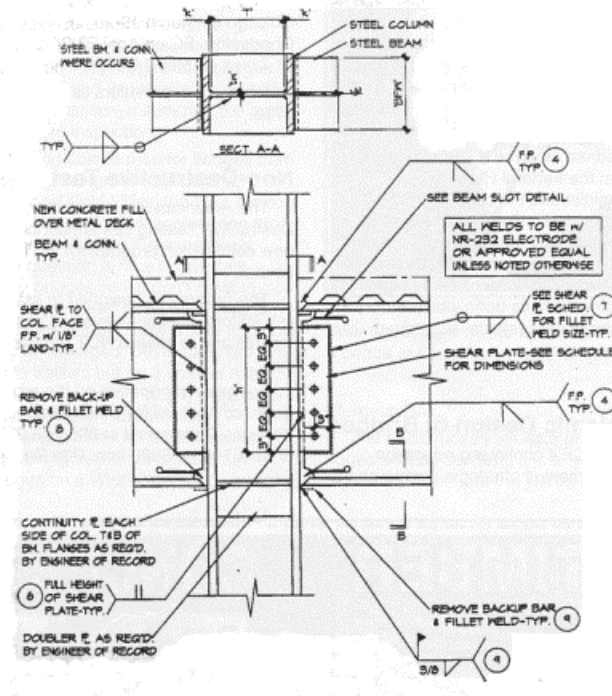

Fig. 4.3.3.6 Proprietary Slotted Beam Connection

Weld Position. Of the four weld positions – flat, horizontal, vertical, and overhead – flat and horizontal are the most economical and usually result in the best quality welds. Thus, the design modifications should be planned so that the weld can be made in the flat or horizontal position whenever possible. For example, suppose cover plates are to be added to the top and bottom flanges of a beam that is accessible from the top. Make the top cover plates narrower than the beam flange and the bottom cover plates wider than the beam flange. With this detail, both plates can be fillet welded to the beam in the horizontal welding position.

Surface Conditions. Surface contaminants such as paint, oil, and grease should be removed before welding. If the steel is galvanized, remove it in the vicinity of the weld by grinding. Severely corroded steel should be cleaned to bare metal. Grind or thermal cut any corroded edges to provide a proper surface for welding.

Weather Conditions. The following weather related cautions should be noted:

- Do not weld if the steel temperature is below 0°F.
- For temperatures between 0°F and 32°F, preheat and maintain the steel at 70°F except where a greater temperature is required by the WPS.
- Do not weld on wet or frost-covered surfaces.
- In frigid weather, review the need for post-heating to slow the cooling rate and let harmful gases escape.
- Provide protection from wind.
- Avoid artificial cooling.
- Protect electrodes from adverse moisture conditions.

Service Load Conditions. The nature of the service loads acting on the structure should be considered when designing reinforcement. For fatigue loadings, the stress range at service loads will depend on the detail selected. Although it is always good practice to avoid notch-like details, this is especially important where impact or fatigue loadings are involved. In general, it is considered good practice to avoid transverse welding on highly stressed members.

Loads During Retrofit. The Engineer should also determine the extent to which a member will

be permitted to carry loads while heating, welding, or thermal cutting. The local and general instability of the member should be investigated, considering the effect of the elevated temperatures over parts of the cross section caused by such operations. Where necessary, loads on beams can be relieved by shoring. (See 5.2.1: AWS, 1996.) Elevated temperatures tend to decrease both the modulus of elasticity, the yield stress, and the tensile strength. It has been suggested that a reasonable approach is to assume that for relatively thin members, an area of steel along each weld, 1-in. wide by the material thickness, is temporarily ineffective during welding. Properties of the original member with this area removed can be calculated and used to assess the need for load reduction. In many common cases, no load reduction will be needed. (See 5.2.1: Tide, 1988.)

Fire Hazards. It is important to follow all governing fire codes, regulations, and safety rules to avoid fires. Welding, thermal cutting, grinding, arc-air gouging and other operations can cause sparks or droplets of molten metal to fall. All precautions must be taken to avoid contact of such with combustible materials.

4.5 Thermal Cutting of Existing Members

Thermal cutting of existing members is sometimes required to remove damaged material or make alterations. In such cases, the basic quality control requirements set forth in the AISC LRFD *Specification* (see Art. M2.2) should be followed. This includes reference to appropriate provisions of AWS D1.1 and limits on surface roughness, gouges, and notches, as well as requirements for contours at re-entrant corners, beam copes, and weld access holes. Additionally, for beam copes and weld access holes in ASTM A6/A6M Group 4 and 5 shapes and welded built-up shapes with material thickness greater than 2 in. (50 mm), a preheat temperature of not less than 150-F (66C) is required prior to thermal cutting.

Whenever the section of a structural member is reduced by removal of material, the effects on structural integrity must be carefully reviewed by the Engineer. If thermal cutting is done while the member is loaded, an evaluation of the strength of the reduced section member must be made under the loads acting. See the discussion in Section 4.4 above under “Loads During Retrofit.”

4.6 Drilling Holes in Existing Members

Holes such as required for bolting on reinforcing material can be drilled, provided the strength of the member is not compromised. The effect of such holes on strength depends on the type of member – tension, compression, or flexural – and is covered in the *AISC Specification*. Evaluations must be made for the final member loading, as well as for any loads present at the time the holes are drilled. Large holes in members, such as for access holes, or for pipe runs or air ducts, should be carefully reviewed to determine possible need for local reinforcing.

Chapter 5

REFERENCES ON REHABILITATION AND RETROFIT

5.1 Reference List

Summaries of the following articles are provided in 5.2.1 General Retrofit, 5.2.2 Case Studies, or 5.2.3 Seismic Retrofit, as indicated below.

- Andrews, William A., "Renovating for the Future," *Modern Steel Construction*, AISC, January 1991. (See 5.2.2)
- Anon., "Pacific Place, San Francisco, California," *Modern Steel Construction*, AISC, March 2000. (See 5.2.2)
- Anon., "Carmel High School, Carmel, Indiana," *Modern Steel Construction*, AISC, March 2000. (See 5.2.2)
- Anon., "University of Northern Iowa Air Dome Retrofit, Cedar Falls, Iowa," *Modern Steel Construction*, AISC, June 1999. (See 5.2.2)
- Anon., "Economic Seismic Connection Repairs: Weld Overlays," *Modern Steel Construction*, AISC, January 1998. (See 5.2.3)
- Anon., "Bombs Away," *Modern Steel Construction*, AISC, February 1998. (See 5.2.2)
- Anon., "Top-Down Construction Renews Historic Construction," *Modern Steel Construction*, AISC, January 1993. (See 5.2.2)
- Anon., "Special Design Isolates Vibration," *Modern Steel Construction*, AISC, January 1992. (See 5.2.2)
- Anon., "Historic Expansion," *Modern Steel Construction*, AISC, March 1992. (See 5.2.2)
- Anon., "Updating a Sports Institution," *Modern Steel Construction*, AISC, March 1992. (See 5.2.2)
- Anon., "Schoolroom Expansion," *Modern Steel Construction*, AISC, October 1991. (See 5.2.2)
- Avent, R. Richard, "Designing Heat Straightening Repairs," *Modern Steel Construction*, AISC, 1995. (See 5.2.1.)
- Avent, R. Richard, "Engineered Heat Straightening Comes of Age," *Proceedings of the National Steel Construction Conference*, AISC, Las Vegas, NV, 1992. (See 5.2.1.)
- American Welding Society (AWS), "Structural Welding Code - Steel," ANSI/AWS D1.1-96, 1996. (See 5.2.1.)
- de Boer, Cornelis J., "Trinity Church Good for Another 250 Years!," *Modern Steel Construction*, AISC, Number 1, 1989. (See 5.2.2)
- Bouffard, Thomas A., "Urban Transformation," *Modern Steel Construction*, AISC, April 1993. (See 5.2.2)
- Brown, J. H., "Reinforcing Loaded Steel Compression Members," *Engineering Journal*, Vol. 25, No. 4, AISC, 1988. (See 5.2.1)
- Buell, Ethan and Carroll, David, "Rebuilding Wood Trusses with Steel," *Modern Steel Construction*, AISC, January 1998. (See 5.2.2)
- Chhibber, KulBhushan L., "New Roof Enclosure Extends Plant Life," *Modern Steel Construction*, AISC, December 1992. (See 5.2.2)
- Conway, Geoff, "Yale Music Library Addition," *Modern Steel Construction*, AISC, January 2000. (See 5.2.2)

- Ennis, Marie, "Steel Revives Historic Structure," *Modern Steel Construction*, AISC, January 2001. (See 5.2.2)
- Federal Emergency Management Agency (FEMA), *Interim Guidelines: Evaluation, Repair, Modification and Design of Welded Steel Moment Frame Structures*, FEMA 267, August 1995; and *Interim Guidelines Advisory No. 2*, FEMA 267B, June 1999. (See 5.2.3)
- Federal Energy Management Agency (FEMA), *NEHRP Guidelines for the Seismic Rehabilitation of Buildings*, No. 273, FEMA, Washington, D.C., 1997. (See 5.2.3)
- Federal Energy Management Agency (FEMA), *NEHRP Commentary on the Guidelines for the Seismic Rehabilitation of Buildings*, No. 274, FEMA, Washington, D.C., 1997. (See 5.2.3)
- Federal Energy Management Agency (FEMA), *Recommended Seismic Design Criteria for New Moment Resisting Steel Frames*, No. 350, FEMA, Washington, D.C., July 2000. (See 5.2.3)
- Federal Energy Management Agency (FEMA), *Recommended Seismic Evaluation and Upgrade Criteria for Existing Welded Steel Moment-Resisting Frame Construction*, No. 351, FEMA, Washington, D.C., July 2000. (See 5.2.3)
- Federal Energy Management Agency (FEMA), *Recommended Post-Earthquake Evaluation and Repair Criteria for Existing Welded Steel Frame Structures*, No. 352, FEMA, Washington, D.C., July 2000. (See 5.2.3)
- Federal Energy Management Agency (FEMA), *Recommended Quality Assurance Guidelines for Moment-Resisting Steel Frame Construction*, No. 353, FEMA, Washington, D.C., July 2000. (See 5.2.3)
- Federal Energy Management Agency (FEMA), *Recommended Specifications for Moment-Resisting Steel Frames for Seismic Applications*, No. 354, FEMA, Washington, D.C., July 2000. (See 5.2.3)
- Federal Emergency Management Agency (FEMA), *Seismic Evaluation & Upgrade Criteria for Existing Welded Steel Moment-Resisting Frame Structures*, SAC Joint Venture Report No. SAC-2000-02-b, Sacramento, CA, 2000. (See 5.2.3)
- Fierro, Eduardo; Perry, Cynthia L.; and Varner, Thomas R., "Damping System Aids Seismic Retrofit," *Modern Steel Construction*, AISC, July 1992. (See 5.2.2)
- Goldberg, Nancy B., "Monumental Stair Design," *Modern Steel Construction*, AISC, December 1991. (See 5.2.2)
- Gordy, Howell A., "South Shore Plaza," *Modern Steel Construction*, AISC, August 1997. (See 5.2.2)
- Greco, Adam, "Renovation Creates New Landmark," *Modern Steel Construction*, AISC, December 1997. (See 5.2.2)
- Gregorian, Zareh B. and Gregorian, Garen B., "Converting a Warehouse," *Modern Steel Construction*, AISC, January 2000. (See 5.2.2)
- Gregorian, Zareh B., "Steel Bracing Stabilizes Concrete Building," *Modern Steel Construction*, AISC, January 1997. (See 5.2.2)
- Gross, John L., Englehardt, Michael D., Uang, Chia-Ming, Kasai, Kazuhiko, and Iwankiw, Nestor R., "Modification of Existing Steel Welded Moment Frame Connections for Seismic Performance," *Design Guide No. 12*, AISC, 1999. (See 5.2.3)
- Hanagan, Linda M. and Murray, Thomas M., "Experimental Implementation of Active Control to Reduce Annoying Floor Vibrations," *Engineering Journal*, Vol. 35, No. 4, AISC, 1998. (See 5.2.1)
- Hill, R., Conroy, R. D., and Hutchinson, J., "Welding Solutions for Turbine

- Generator Plant Repair, Upgrade, and Life Extension,” Conference Publication No. 401, IEE, 1994. (See 5.2.1)
- Isbell, John E. and Krol, Ted, “Complex Supports for Steel-Girded Skyway,” *Modern Steel Construction*, AISC, January-February 1990. (See 5.2.2)
- Johnston, Michael, “Windows of Opportunity,” *Modern Steel Construction*, AISC, April 1992. (See 5.2.2)
- Kennedy, D. Scott, “Public Market to Ballroom,” *Modern Steel Construction*, AISC, January 2001. (See 5.2.2)
- Kennedy, Scott, “Rebuilding After Northridge,” *Modern Steel Construction*, AISC, November 1997. (See 5.2.2)
- Keyes, Charles D., “Theatrical Renovation,” *Modern Steel Construction*, AISC, February 1993. (See 5.2.2)
- Koesis, Peter, Discussion of paper by Miller, John P., “Strengthening of Existing Composite Beams Using LRFD Procedures,” *Engineering Journal*, Vol. 34, No. 3, AISC, 1997. (See 5.2.1)
- Kestner, James W., “Vertical Expansion Adapts to Changing Needs,” *Modern Steel Construction*, AISC, June 1993. (See 5.2.2)
- Kouyoumdjian, Hratch, “Renovating Concrete,” *Modern Steel Construction*, AISC, March 1999. (See 5.2.2)
- Lundeen, Terry; Perbix, Todd; and Schwartz, John, “Renovation of a Historic Steam Generating Plant for Biotechnical Research Use,” *Proceedings of the National Steel Construction Conference*, AISC, Pittsburgh, PA, 1994. (See 5.2.2)
- Lahti, Michael A., “Transfer Truss Supports Renovation,” *Modern Steel Construction*, AISC, September 1996. (See 5.2.2)
- Louie, Jason J. C. and Mladjov, R. V., “Sculptural Steel,” *Modern Steel Construction*, AISC, December 1997. (See 5.2.2)
- Marquardt, Daniel F. and Levy, Elyse G., “Steel Pays Off for Payroll Producer,” *Modern Steel Construction*, AISC, January 1999. (See 5.2.2)
- Merovitch, Andrew T., “Seismic Upgrade for A Concrete Frame,” *Modern Steel Construction*, AISC, March 1999. (See 5.2.2)
- Messinger, David L., Cohen, Jeff, and Chun, Kearny, “Strengthening Behind the Scenes,” *Modern Steel Construction*, AISC, January 1991. (See 5.2.2)
- Miller, John P., “Strengthening of Existing Composite Beams Using LRFD Procedures,” *Engineering Journal*, Vol. 33, No. 2, AISC, 1996. (See 5.2.1)
- Nelson, Ben, “Gym Infill Requires Structural Strengthening,” *Modern Steel Construction*, AISC, April 1991. (See 5.2.2)
- Nagaraja Ras, N.R. and Tall, Lambert, “Columns Reinforced Under Load,” *Welding Journal*, Vol. 42, AWS, April 1963. (See 5.2.1)
- Peterman, Mark B., “Rebuilding a Landmark,” *Modern Steel Construction*, AISC, February 1996. (See 5.2.2)
- Punch, Steve and Wall, Sidney S., “Constant Growth,” *Modern Steel Construction*, AISC, July 1994. (See 5.2.2)
- McIntyre, Brian, “Renovation Expands Seattle Supersonic’s Home Court,” *Modern Steel Construction*, AISC, September 1997. (See 5.2.2)
- Popovic, Predrag L., “Structural Repairs and Strengthening of a 360,000 Square Foot Warehouse,” *Proceedings of the National Steel Construction Conference*, AISC, Las Vegas, NV, 1987. (See 5.2.2)

- Rabun, J. Stanley, *Structural Analysis of Historic Buildings*, John Wiley & Sons, Inc., 2000.
- Rajagopaian, K. S. and Williams, Robert G., "New Skin Profile Made Possible with Welded Trusses," *Modern Steel Construction*, AISC, No. 4, 1989. (See 5.2.2)
- Richard, Ralph M., Allen, C. Jay, and Partridge, James E., "Proprietary Slotted Beam Connection Designs," *Modern Steel Construction*, AISC, March 1997. (See 5.2.3)
- Ricker, David T., "Field Welding to Existing Steel Structures," *Engineering Journal*, Vol. 25, No. 1, AISC, 1988. (See 5.2.1)
- Ricker, David T., "Field Welding to Existing Steel Structures," *Proceedings of the National Engineering Conference and Conference of Operating Personnel*, AISC, New Orleans, LA, 1987. (No summary given. Similar to above cited EJ article.)
- Robinson, Keith and Ames, Debbie, "Library Seismic Upgrade," *Modern Steel Construction*, AISC, January 2000. (See 5.2.2)
- Roloff, Steven J., "Matching Heights," *Modern Steel Construction*, AISC, July 1994. (See 5.2.2)
- Ruddy, John L., "Reinforcing In-Plane Structural Elements," *Proceedings of the National Engineering Conference and Conference of Operating Personnel*, AISC, New Orleans, LA, 1987. (See 5.2.1)
- Sadeghpour, David H., "Vertical Expansion," *Modern Steel Construction*, AISC, June 1996. (See 5.2.2)
- Simon, Warner et al, "Repair of Existing Steel Moment Frame Buildings Damaged from Earthquakes Using Fracture Tough Weld Overlays," *Engineering Journal*, Vol. 36, No. 4, AISC, 1999. (See 5.2.3)
- Sopko, Stephen J. and Benjamin, Susan, "Vertical Steel Addition Cures Hospital's Space Woes," *Modern Steel Construction*, AISC, July-August 1990. (See 5.2.2)
- Spraragen, W. and Grapnal, S.L., "Reinforcing Structures Under Load," *Welding Journal*, Vol. 23, Research Supplement 65-S, Feb. 1944. (See 5.2.1)
- Tall, Lambert, "The Reinforcement of Steel Columns," *Engineering Journal*, Vol. 26, No. 2, AISC, 1989. (See 5.2.1)
- Thayer, Gary E. and Rim, Kurt K., "Preserving Cleveland's History," *Modern Steel Construction*, AISC, June 1991. (See 5.2.2)
- Thayer, Gary E. and Rim, Kurt K., "Historic Bank Renovation at Society Center – Cleveland, Ohio," *Proceedings of the National Steel Construction Conference*, AISC, Washington, DC, 1991. (No summary, similar to above "Preserving Cleveland's History".)
- Thornton, Charles H., Hungsproke, Udom, and DeScenza, Robert P., "Vertical Expansion of Vintage Buildings," *Modern Steel Construction*, AISC, June 1991. (See 5.2.1)
- Thornton, Charles H., Hungsproke, Udom, and DeScenza, Robert P., "Vertical Expansion to Add 235,000 Sq. Ft.," *Modern Steel Construction*, AISC, June 1991. (See 5.2.2)
- Thornton, Charles H., et al, "Economic Upgrading of Vintage Buildings," *Modern Steel Construction*, AISC, July 1991. (See 5.2.2)
- Tide, R. H. R., "Integrity of Structural Steel After Exposure to Fire," *Engineering Journal*, Vol. 35, No. 1, AISC, 1998. (See 5.2.1)
- Tide, R. H. R., "Reinforcing Steel Members and the Effects of Welding," *Engineering Journal*, Vol. 2, No. 4, AISC, 1990. (See 5.2.1)

- Tide, Raymond H. R., "Basic Considerations When Reinforcing Existing Steel Structures," *Proceedings of the National Engineering Conference and Conference of Operating Personnel*, AISC, New Orleans, LA, 1987. (See 5.2.1)
- Timler, Peter A. and Sherstobitoff, John G., "Seismic Retrofit for the British Columbia Institute of Technology," *Proceedings of the National Steel Construction Conference*, AISC, Pittsburgh, PA, 1994. (See 5.2.2)
- Timler, Peter A. and Sherstobitoff, John G., "External Bracing Provides Seismic Support," *Modern Steel Construction*, AISC, 1995. (No summary, similar to above "Seismic Retrofit for the British Columbia Institute of Technology".)
- Torrelo, George Jr. and Epstein, Howard I., "Composite Action Crucial for Renovation," *Modern Steel Construction*, AISC, May-June 1990. (See 5.2.2)
- Totten, Craig, "Portland Airport Expansion," *Modern Steel Construction*, AISC, January 2000. (See 5.2.2)
- Uang, Chia-Ming and Bondad, Duane, "Improving the Seismic Performance of Pre-Northridge Steel Moment Frame Connections with Haunches," *Proceedings of the National Steel Construction Conference*, AISC, Phoenix, AZ, 1996. (See 5.2.3)
- Vincent, John F., Corley, Gene, and Kosel, Hans C., "Do Not Disturb," *Modern Steel Construction*, AISC, February 1993. (See 5.2.2)
- Wathne, John M., "Practical Thermal Prestressing," *Modern Steel Construction*, AISC, February 1996. (See 5.2.2)
- Ward, Bruce A. and Noel, Paul D., "Adaptive Reuse Adds Technical Center," *Modern Steel Construction*, AISC, December 1995. (See 5.2.2)
- Weissberg, Stephen M.; Van Volkinburg, David R.; Mayes, Ronald L.; and Jones, Lindsay R., "An Alternative for Earthquake Design," *Modern Steel Construction*, AISC, January 1991. (See 5.2.3)
- Wolfe, John; Mar, David; and Tipping, Steve, "Propped Shear Walls," *Modern Steel Construction*, AISC, January 2001. (See 5.2.3)
- Wyllie, Loring A.; Dal Pino, John A.; and Cohen, Jeff, "Seismic Upgrade Preserves Architecture," *Modern Steel Construction*, AISC, January 1991. (See 5.2.2)
- Xue, Ming; Kaufmann, Eric J.; Lu, Le-Wu; and Fisher, John W., "Achieving Ductile Behavior of Moment Connections," Part I, *Modern Steel Construction*, AISC, January 1996; Part II, *Modern Steel Construction*, AISC, June 1996. (See 5.2.2)
- Zekioglu, Atila, et al "Designing After Northridge," *Modern Steel Construction*, AISC, March 1997. (See 5.2.3)

5.2 Summaries of References

5.2.1 General Retrofit

Avent, R. Richard, "Designing Heat Straightening Repairs," *Modern Steel Construction*, AISC, 1995. (See 5.2.1.)

Summary: Based on completed analytical and experimental studies on heat straightening, basic concepts are presented and heating patterns recommended for repairs. Limitations on temperatures and jacking forces are given. Examples of bridge repairs and cost savings are cited.

Avent, R. Richard, "Designing Heat Straightening Repairs," *Proceedings of the National Steel Construction Conference*, AISC, Las Vegas, NV, 1992.

Summary: Experiments were conducted on heavily damaged steel plates and rolled shapes subjected to heat straightening. Effects of the repair process on tensile properties and residual stresses were determined. Design guidelines

were developed regarding the use and limitations of heat straightening with regard to degree of damage, repetitive damage, detrimental effects of steel properties caused by certain heating patterns, and analytical prediction of movement.

American Welding Society (AWS), "Structural Welding Code - Steel," ANSI/AWS D1.1-96, 1996.

Summary: Retrofit is addressed in Chapter 8, "Strengthening and Repairing Existing Structures." Subjects covered include suitability of the base metal for welding, design for strengthening and repair, fatigue life enhancement, workmanship and technique, and quality.

Brown, J. H., "Reinforcing Loaded Steel Compression Members," *Engineering Journal*, Vol. 25, No. 4, AISC, 1988. (See 5.2.1)

Summary: A method is developed for calculating the ultimate capacity of a column reinforced under load based on rational analysis but not substantiated by testing. The paper treats the reinforced column as a frame with two members, the reinforcement and the un-reinforced column, joined to each other by rigid links. It is shown that both the geometry of the reinforcement and the initial load can affect column capacity.

Hanagan, Linda M. and Murray, Thomas M., "Experimental Implementation of Active Control to Reduce Annoying Floor Vibrations," *Engineering Journal*, Vol. 35, No. 4, AISC, 1998.

Summary: When excessive levels of floor vibration disturb the occupants or impair the function of a facility, repair measures are often sought. This paper discusses the role of damping and the application of active control in reducing unacceptable floor motion. The practical implementation of active control, using an electro-magnetic force actuator in a computer control velocity feedback loop, is also described. Finally, experimental results for two temporary installations, an office floor and a chemistry laboratory floor, are presented to illustrate the effectiveness of the active control scheme.

Hill, R., Conroy, R. D., and Hutchinson, J., "Welding Solutions for Turbine Generator Plant Repair, Upgrade, and Life Extension," Conference Publication No. 401, IEE, 1994.

Summary: Opportunities are presented to power generation plant operators and manufacturers by the development of methods for the repair and refurbishment of turbines and ancillary plant equipment. The philosophy and experiences of the authors are presented to demonstrate the important role that welding plays in the provision of cost effective solutions for ensuing plant availability, improvement of operational integrity, and life extension.

Koesis, Peter, Discussion of paper by Miller, John P., "Strengthening of Existing Composite Beams Using LRF D Procedures," *Engineering Journal*, Vol. 34, No. 3, AISC, 1997.

Summary: The method presented by Miller requires sufficient headroom to add the reinforcement below the existing beam. However, Koesis presents an alternative method using steel cables located within the beam profile instead.

Miller, John P., "Strengthening of Existing Composite Beams Using LRF D Procedures," *Engineering Journal*, Vol. 33, No. 2, AISC, 1996.

Summary: Often the capacity of an existing composite steel floor beam must be increased, such as to accommodate a change in occupancy. One of the many advantages of a steel framed structure is the relative ease and economy with which this retrofit can be made. This paper describes a procedure for the rapid direct solution for the required steel reinforcement to be added to resist a given bending moment in such cases. A design aid and example hand calculations are given, using a flat plate or a WT for reinforcement. The procedure is LRF D based but may be used for LRF D or ASD, and with solid concrete slabs or slabs on metal deck. (See discussion by Koesis, Peter, *Engineering Journal*, Vol. 34, No. 3, AISC, 1997.

Nagaraja Ras, N.R. and Tall, Lambert, "Columns Reinforced Under Load," *Welding Journal*, Vol. 42, AWS, April 1963.

Summary: Tests were conducted on a W8x31 column with a slenderness ratio of 48. The tests showed that welding on reinforcing flange plates, while the column was subjected to a 91.2 kip load, resulted in an ultimate strength no less than the same column reinforced under no load. It was

seen that the column strength could be increased by the beneficial effects of an improved residual stress distribution.

Rabun, J. Stanley, *Structural Analysis of Historic Buildings*, John Wiley & Sons, Inc., 2000.

Summary: This text addresses restoration, preservation, and adaptive reuse applications for architects and engineers. Included are the following chapters:

1. Assessment Methodology: Material Chronology, Early Building Laws, and Loads
2. Foundation Systems of American Historic Buildings
3. Historic American Building Systems: Walls and Columns
4. Historic American Floor Systems: Beams
5. Historic American Roof Systems: Lateral Bracing of Buildings
6. The Historic material Assessment

The author states the following: "The designer in charge of the work must exercise professional judgment in deciding how much analysis is to be done. The recommended approach is to use the modern methods of analysis, the historic member section properties (its geometric properties), and the allowable stresses of the period. This method is still conservative and may require the designer to modify allowable stresses in cases where good engineering judgment permits. For instance, early structural steel allowable stresses were specified at 50 percent of the yield stress of the material. We have been utilizing two-thirds of the yield value since the 1950s, with remarkable success. Specific design dimensions, character of end conditions, bearing, among other factors, require that certain modifications of allowable stresses be made and engineering judgment is again required."

Ricker, David T., "Field Welding to Existing Steel Structures," *Engineering Journal*, Vol. 25, No. 4, AISC, 1988.

Summary: Field welding to existing members is becoming increasingly common. During the recycling of older structures, new performance requirements often necessitate the addition of reinforcing material to increase load carrying capacity, to restore areas eroded by corrosion, to strengthen fire-weakened members, or perhaps to alter the appearance of a member by changing its

shape for aesthetic reasons. One of the many advantages of a steel frame structure is that it can be reworked more readily than structures using other materials. Field conditions are often far from ideal and it is necessary to ascertain the effects of the fieldwork on the existing structure, especially the common method of attachment - welding. Safety, economic considerations, and the endless search for understanding and refinement require us to seek deeper into the subject of field welding to existing steel structures. The following items merit attention: weldability of existing and new steel, selection and design of welds, anatomy of welds, heat input, position of weld, surface conditions, weather conditions, nature of the load, nature of the reinforcing, shoring and stress relieving, reinforcing connections, effect of field alterations on entire structure, fire hazards and precautions, and testing and inspection.

Ruddy, John L., "Reinforcing In-Plane Structural Elements," *Proceedings of the National Engineering Conference and Conference of Operating Personnel*, AISC, New Orleans, LA, 1987.

Summary: This paper examines the various alternatives available to a structural engineer when confronted with the problem of reinforcing the beams and girders of an existing floor. The floor was analyzed by both methods, Allowable Stress Design (ASD) and Load and Resistance Factor Design (LRFD).

Four different types of bottom cover plates were tried using the following approaches:

1. Maintain the extreme fiber stress at or below the specified allowable, recognizing dead load (ASD).
2. Shore to relieve dead load stresses and maintain the extreme fiber stresses below specified allowable stresses (ASD).
3. Neglect the existing dead load stress and ensure the plastic moment capacity of the section is adequate (LRFD).

The paper discusses the results of the study and the significance of the assumption in each of the solutions.

Spraragen, W. and Grapnal, S.L., "Reinforcing Structures Under Load," *Welding Journal*, Vol. 23, Research Supplement 65-S, Feb. 1944.

Summary: This early article suggests that a safe condition exists in a reinforced member as long as the maximum stress in the original member does not exceed 4/3 of the average stress in the combined section. The average stress in the combined section is limited to the usual allowable stress for the member.

Tall, Lambert, “The Reinforcement of Steel Columns,” *Engineering Journal*, Vol. 26, No. 2, AISC, 1989.

Summary: The author addresses the reinforcement of columns under load. Methods include the addition of cover plates, changing the residual stress distribution across the column cross section, or both. For columns carrying design loads, reinforcement is both possible and safe. The strength of columns reinforced under load and reinforced under no load is identical. The maximum effect of reinforcement is obtained when the reinforcing weld is as close as possible to the edge of the flange of the base shape.

Thornton, Charles H., Hungspreke, Udom, and DeScenza, Robert P., “Vertical Expansion of Vintage Buildings,” *Modern Steel Construction*, AISC, June 1991.

Summary: An understanding of the design practices employed in the past can greatly simplify a renovation project. Review of as-built drawings, field observations and measurements, and comparison of analysis methods and codes used at the time of construction with present requirements, are all important. The writers divide the 20th century into six vintage periods and characterize design practices.

Tide, R. H. R., “Integrity of Structural Steel After Exposure to Fire,” *Engineering Journal*, Vol. 35, No. 1, AISC, 1998.

Summary: This paper describes procedures for evaluating steel structures exposed to fires. The writer confirms in his conclusions that, if a member is still straight after a fire, the steel is ok.

Tide, R. H. R., “Reinforcing Steel Members and the Effects of Welding,” *Engineering Journal*, Vol. 2, No. 4, AISC, 1990.

Summary: The author reviews and disagrees with several papers that propose methods for designing reinforcement for columns under load.

The author suggests that the following questions should be addressed in the design of reinforcement: 1. Are current and future loads static or cyclically applied? 2. What is the ratio between the in-situ load and the original design load? 3. What is the type and condition of the steel? 4. Is local buckling a possibility? 4. How does the stability of each individual compression member affect the overall stability of the whole system? 5. What safety factor must be maintained during the reinforcing operation?

Tide, Raymond H. R., “Basic Considerations When Reinforcing Existing Steel Structures,” *Proceedings of the National Engineering Conference and Conference of Operating Personnel*, AISC, New Orleans, LA, 1987.

Summary: This paper discusses the key issues that must be considered to arrive at a solution that is practical and safe to implement, and at the same time reasonably economical. Field conditions often present a less than ideal working environment and limitations on the length of shutdown time may also be a factor. Attaching reinforcement components by welding to existing members poses several problems. The pertinent items to be considered when retrofitting existing structures are identified. An evaluation of the distribution of forces in both the original member and new components is discussed.

5.2.2 Retrofit Case Studies

Andrews, William A., “Renovating for the Future,” *Modern Steel Construction*, AISC, January 1991.

Summary: An eight-story building in Oakland, California was damaged by the Loma Prieta earthquake. It had been constructed in two phases, beginning in the 1920s with a three-story concrete frame and shear wall structure. In 1956, an eight-story steel frame structure was built adjacent to the existing structure, with two stories extending over and supported on the old concrete structure. For compatibility, a concrete shear wall was added in the bottom three stories of the steel building. To provide lateral bracing for the penthouse, x-braces of hollow structural sections were welded to the existing framing. Some beam-to-column connections were strengthened by fillet welding plates to the beam flanges and complete penetration welding to the column. Various other retrofits were also made

to bring the lateral system up to 1988 UBC requirements.

Anon., "Pacific Place, San Francisco, California," *Modern Steel Construction*, AISC, March 2000.

Summary: This project was a major reconstruction and seismic upgrade of a Category 1 historic building. When built in 1908, it was the largest concrete office building in the United States. The structure was a ten story non-ductile concrete frame, 192 x 144 ft in plan, with columns on a 16 x 16 ft grid. To provide prime retail space, the lower four stories were completely demolished and three floors reconstructed in their place. Of the original 86 columns, 74 were removed, 12 were strengthened, and 15 new ones were added. Concrete shear walls and steel braced frames were mixed in the seismic upgrade. Friction dampers were added, utilizing sandwiched brass shims, pre-tensioned bolts and slotted holes. This project was a National Winner in AISC's Engineering Awards of Excellence program.

Anon., "Carmel High School, Carmel, Indiana," *Modern Steel Construction*, AISC, March 2000.

Summary: A durable steel-framed system was selected to replace a deteriorating wood bowstring truss roof structure over a gymnasium. Curved W36x170 beams were erected 10 ft above the existing roof to achieve a tied arch configuration over a 176 ft span. Construction was carefully planned so that the basketball season was unaffected. This project was a Merit Winner in AISC's Engineering Awards of Excellence program.

Anon., "University of Northern Iowa Air Dome Retrofit, Cedar Falls, Iowa," *Modern Steel Construction*, AISC, June 1999.

Summary: The UNI-Dome, completed in 1975, was the first indoor stadium with a full-size, air-supported fabric roof system. Removal of heavy snowfalls from such domes has proven to be a major drawback and, in this case, led to a rip in the fabric and deflation. The retrofit consisted of a system of arch trusses with tensioning cables. There are four main arches, 400-ft long, and 16 secondary arches, 107 ft long. The structure's periphery was prestressed with post-tensioning cables to form a tension ring. This project was a

Merit Winner in AISC's Engineering Awards of Excellence program.

Anon., "Bombs Away," *Modern Steel Construction*, AISC, February 1998.

Summary: This radical renovation included a seismic update and a complete cosmetic makeover to an existing 50-year-old, one-story un-reinforced masonry building near downtown Los Angeles. The unusual design called for deactivated World War II bombs that appeared to penetrate glass windows without visible support. Unusual steel space frames were key parts of the renovation.

Anon., "Top-Down Construction Renews Historic Construction," *Modern Steel Construction*, AISC, January 1993.

Summary: Converting a deteriorated office building into a new parking facility while retaining its elegant brick bearing wall exterior required the coordination of the entire building team. This five-story 1868 Syracuse office building was converted into six levels of parking while the exterior was restored to its original condition. To accomplish this, they decided to remove one bay around the periphery of the structure and replace it with a steel frame, then remove and replace the rest of the structure. To keep the exterior wall braced, they threaded columns through the roof, inserted beams through window openings, and built the outside bay from the top down while continuously keeping the rest of the internal wood structure intact.

Anon., "Special Design Isolates Vibration," *Modern Steel Construction*, AISC, January 1992.

Summary: Almost all of the construction for a large expansion of a hospital surgery building in Illinois was to occur over occupied space while the hospital remained fully functional. To eliminate noise and vibration to the space below, the designers developed a special stub column consisting of a hollow structural section topped with a neoprene pad. These short columns were installed directly over the existing concrete columns and the new steel columns were erected on top.

Anon., "Historic Expansion," *Modern Steel Construction*, AISC, March 1992.

Summary: The conversion of a former Albany, New York museum to office space required the addition of mezzanines to increase occupiable space and improve acoustics. The five-story 1908 building is distinguished by a 520-ft long, load-bearing Corinthian colonnade, reportedly the world's largest. In this project, the fifth floor, which had been a museum for many years, was converted to office space. Mezzanines were inserted into each of the three exhibit wings to increase usable space. To support them, columns were extended and outriggers attached. Heavy non-structural concrete floors were removed and replaced with lightweight concrete to reduce dead weight. To reduce vibrations, weight was added to the mezzanines at critical locations.

Anon., "Renovation Without Disruption," *Modern Steel Construction*, AISC, March 1992.

Summary: A walkway connection between the ninth floor of an existing building and two new buildings had to be constructed with minimal worker disturbance. It was determined that an opening could be made in the end walls of the existing building, but vertical bracing was needed for seismic Zone 2 compliance. This included adding bracing between the ninth and tenth floors to form hat trusses running the width of the building to increase overturning resistance. The final solution utilized bolted Vierendeel trusses.

Anon., "Updating a Sports Institution," *Modern Steel Construction*, AISC, March 1992.

Summary: The renovation of Madison Square Garden included adding sky-boxes and a sky-lobby, constructing a mezzanine over a taxi plaza, and enlarging a theater. This had to be accomplished without disrupting the many scheduled events. The Garden's design features a 425-ft diameter cable supported roof, which was designed with a larger safety factor than current codes require. Therefore, to provide column-free space, it was possible to hang the new sky-boxes and sky-lobby from the existing cable structure. The new mezzanine was also hung but, in this case, from existing overhead girders.

Anon., "Schoolroom Expansion," *Modern Steel Construction*, AISC, October 1991.

Summary: A steel-framed high school built in the 1960s was easily expanded to accommodate large science classrooms. The school district

wanted to convert several small classrooms into larger laboratory spaces. The plan was to add six 20 x 32 ft bays to the first floor and leave the second floor alone. The solution was to fabricate trusses from hollow structural sections, weld them to the existing line of columns, then remove every other column in the first floor wall.

DeBartolo, Jack Jr., and Moson, Frank B., "On-Site Development Optimizes Hospital Efficiency," *Modern Steel Construction*, AISC, No. 2, 1980.

Summary: The original buildings of this hospital in Tucson were constructed before 1880 and were the first such facility in Arizona. Expansion called for four new stories with a connection to the old hospital. The second story of the addition was planned to facilitate the mechanicals. The interstitial space was contained between the top and bottom chords of steel trusses, fabricated with wide-flange chords and hollow-structural-section webs.

de Boer, Cornelis J., "Trinity Church Good for Another 250 Years!," *Modern Steel Construction*, AISC, No. 1, 1989.

Summary: A heavy timber frame building built in 1726 was reinforced with steel. The work had to be completed without on-site welding due to the fire hazard. After rehabilitation, the wood frame had to carry only its self-weight, as the new steel frame resisted the wind loads.

Bouffard, Thomas A., "Urban Transformation," *Modern Steel Construction*, AISC, April 1993.

Summary: An addition to a nearly half-century old department store allowed the creation of a modern urban mall in Silver Spring, Md. The final design utilized the lower four stories of the existing concrete structure for retail space and the upper two stories for office space. Also, a large five-story horizontal addition was erected with retail space and a theater. Steel was chosen as the structural system because of the flexibility it offered in design.

Buell, Ethan and Carroll, David, "Rebuilding Wood Trusses with Steel," *Modern Steel Construction*, AISC, January 1998.

Summary: Moisture damage to structural elements required an innovative solution to preserve a historic structure. The original wood

trusses in the 1909 administration building at Kentucky State University were creeping and deflecting, causing large cracks in the drywall of the second floor and ceiling. The retrofit included new steel trusses, built inside the chords of the existing trusses, one at a time. The new members were inserted through small temporary openings in the finished roof.

Chhibber, KulBhushan L., “New Roof Enclosure Extends Plant Life,” *Modern Steel Construction*, AISC, December 1992.

Summary: Putting a new roof on top of an existing boiler plant superstructure reduced life cycle costs. The original roofs were suspended 200 ft above grade from a superstructure and leakage was causing deterioration. In the retrofit, the superstructures were enclosed with new steel roof framing, standing seam metal roofing, and partial siding.

Conway, Geoff, “Yale Music Library Addition,” *Modern Steel Construction*, AISC, January 2000.

Summary: In this innovative expansion project, an interior courtyard was converted to an attractive three-floor space for library facilities. The architectural focal point of the new addition was the roof structure erected over the old courtyard. It was designed to resemble the gothic window and arch shapes in the original building. Six, 10-ton exposed arch-trusses, with bottom chords made up of tapered and curved plates, were designed to span the 53 ft courtyard.

Ennis, Marie, “Steel Revives Historic Structure,” *Modern Steel Construction*, AISC, January 2001.

Summary: This article describes the restoration and adaptive use of Montezuma Castle, a 90,000 sq. ft structure near Las Vegas, NM. This was a load bearing masonry structure with wood framing. In a key part of the project, steel trusses with bolted field splices were installed to sandwich existing deteriorated timber trusses spanning 60 ft.

Fierro, Eduardo; Perry, Cynthia L.; and Varner, Thomas R., “Damping System Aids Seismic Retrofit,” *Modern Steel Construction*, AISC, July 1992.

Summary: The first commercial application of the “Added Damping and Stiffness Element” in

the U.S. proved successful in retrofitting a bank building in San Francisco. A study made after the Loma Prieta earthquake indicated that the 1967 two-story non-ductile concrete building could be vulnerable in a major seismic event such as the 8+ level 1906 San Francisco earthquake. The building had shown some damage as a result of the Loma Prieta earthquake. Also, the combination of shear walls and moment frames, and restraint of frame action afforded by mezzanine floor, caused a significant torsion problem. Typical alternatives such as adding new shear walls or steel braces were not practical because they would interfere with below-grade parking. Instead a system was designed that employs force-limiting energy dissipation devices in conjunction with steel chevron braces. The patented elements consist of 50 ksi steel plates cut in an hourglass shape that bends in double-curvature when subjected to lateral loading.

Goldberg, Nancy B., “Monumental Stair Design,” *Modern Steel Construction*, AISC, December 1991.

Summary: When new tenants moved into this three-year-old 60-story building in Philadelphia, they decided to have two large stairways added to visually and functionally connect three floors. The addition of the new stairs required reinforcing the existing structure and accessing existing connections, both facilitated by the original frame being steel.

Gordy, Howell A., “South Shore Plaza,” *Modern Steel Construction*, AISC, August 1997.

Summary: This paper describes the vertical expansion and rehabilitation of a 40-year-old shopping mall in Braintree, Ma. on a fast-track schedule. Some existing columns were plated to increase capacity, some replaced with heavier sizes, and some left as is. The work was complicated by the need to keep shopping areas open and the absence of accurate plans for the initial construction.

Greco, Adam, “Renovation Creates New Landmark,” *Modern Steel Construction*, AISC, December 1997.

Summary: A seismic renovation turned an old parking garage into an eye-catching landmark in Berkeley, Ca. The garage was selected for a seismic upgrade to minimize future risk.

Concrete columns and a brick masonry veneer were the main concerns. An exterior steel bracing system was deemed to provide the best solution for strengthening. The result provided a new architectural image for the building as well.

Gregorian, Zareh B. and Gregorian, Garen B., "Converting a Warehouse," *Modern Steel Construction*, AISC, January 2000.

Summary: This paper describes the conversion of a warehouse into an office building. Constructed in 1914, the building featured brick bearing walls on the periphery with wood girders, joists, and floor decking. Some of the brick walls and wood structural elements had deteriorated. One of the major changes was the addition of 32 large windows in a brick-bearing wall that had no openings. An internal steel reinforcing system was chosen to restore lateral load carrying capacity to the wall. Angle assemblies, including top angles to act as lintels, were anchored to the brick inside the opening, then welded to form a rectangular frame in each opening. Steel X-bracing was used to strengthen the building in the short direction.

Gregorian, Zareh B., "Steel Bracing Stabilizes Concrete Building," *Modern Steel Construction*, AISC, January 1997.

Summary: Conversion of a 1920 era concrete parking structure to a high-tech manufacturing facility required removal of part of the existing floor slab and the addition of lateral bracing. The purpose of the Boston University retrofit was to create a state-of-the-art facility for graduate studies in manufacturing engineering. A high-bay area was developed in the center of the two-story building to accommodate an overhead crane and the perimeter of the building was adapted to house various machines. Steel beams were installed at the first floor ceiling to tie exterior and interior columns where the slab was cut to form the high bay area.

Isbell, John E. and Krol, Ted, "Complex Supports for Steel-Girded Skyway," *Modern Steel Construction*, AISC, January-February 1990.

Summary: Steel reinforcement was added to a 1912 building to provide support for a new pedestrian skyway. Some of the problems addressed are, limited working space for installing the reinforcement, upgrading a column,

and lamellar tearing where new welds were made on existing steel.

Johnston, Michael, "Windows of Opportunity," *Modern Steel Construction*, AISC, April 1992.

Summary: A dramatic sloped atrium created a new identity for a 1927 Oklahoma City building. The U-shaped landmark structure was built with the first three stories enclosed, while the upper nine stories were built around an open-air atrium. In the retrofit, the third-floor roof was removed and a full-height sloped-glass atrium was created that extended from a setback over the street-level entry upwards 12 stories to the roof. The lower floors were designated for retail space and the upper for office space. Crosswalks through the atrium supported on an exposed tubular framework connected opposing building wings. The framework also supported the glazing and acted as a diaphragm to transfer loads.

Kennedy, D. Scott, "Public Market to Ballroom," *Modern Steel Construction*, AISC, January 2001.

Summary: This article addresses the means by which the transfer of existing column loads to a new second floor level in the historical 1920 Sacramento Public Market Building was economically, safely, and simply achieved. Columns were removed so that the floor below could be converted into a large ballroom. The architect for the original structure was Julia Morgan, designer of the Hearst Castle, the Fairmont Hotel, and others.

Kennedy, Scott, "Rebuilding After Northridge," *Modern Steel Construction*, AISC, November 1997.

Summary: In order to rebuild a severely damaged parking structure on schedule, the project team turned to a steel design. Initially it was assumed that the concrete parking structure, damaged by the Northridge earthquake, would be replaced with a similar structure. However, a steel proposal was selected because it minimized construction time and reduced costs by 20 percent. The attractive new design featured concentric lateral bracing, hollow structural sections for columns, and wide flange shapes for beams.

Kestner, James W., "Vertical Expansion Adapts to Changing Needs," *Modern Steel Construction*, AISC, June 1993.

Summary: A two-story addition allowed a growing hospital in Green Bay, Wisconsin to add needed outpatient space. The original four-story structure was framed with 5-ft deep trusses spanning 40.5 ft. However, the addition was framed with W section beams and girders designed for partial composite action, because this provided more space for mechanicals and was easier to fireproof. Lateral loads were handled by moment frames in one direction and x-bracing in the other. A heavy truss with Group 4 shapes was designed to span over a "notch" in the original building.

Keyes, Charles D., "Theatrical Renovation," *Modern Steel Construction*, AISC, February 1993.

Summary: The interior of an old arena was completely gutted to make way for a glamorous new theater. The arena was initially constructed around 1900 and, beginning in the 1940s, four adjacent structures were added. All five were joined together in 1991 when a pavilion featuring a suspended floor and atrium roof structure was constructed along with the arena conversion. The old structural system was modified from a three-hinge arch to a three-bay frame with the addition of a series of columns. The renovation made the Denver Arts Center a world-class facility.

Kouyoumdjian, Hratch, "Renovating Concrete," *Modern Steel Construction*, AISC, March 1999.

Summary: Structural steel moment frames are proving to be an attractive alternative for retrofitting concrete structures in seismic areas. Traditionally, the retrofitting scheme has been the introduction of new concrete shear walls within existing spaces and connecting new walls to existing elements to develop a new lateral-load resisting system. To overcome various disadvantages in such a system, structural steel moment frames can be used instead to provide the required lateral strength and stiffness. The gravity load resisting system generally remains the same. An example is the administration building at San Francisco State University. This was a six-story building constructed in 1970 with concrete waffle slabs, and concrete moment resisting frames along both grid lines and a few

limited capacity shear walls. A complete steel framing system was erected along the building exterior with connections to the original frame. A representative full-scale section of the new frame moment connection was successfully tested to verify its performance.

Lahti, Michael A., "Transfer Truss Supports Renovation," *Modern Steel Construction*, AISC, September 1996.

Summary: In New York's Penn Station, which opened in the early 1960's, 11 columns had to be removed to provide for a platform extension. One of the columns was part of a viaduct carrying West 33rd Street. A truss was designed to pick up the column load and transfer it to new columns. A large plate girder was deemed impractical because of construction space constrictions.

Louie, Jason J. C. and Mladjov, R. V., "Sculptural Steel," *Modern Steel Construction*, AISC, December 1997.

Summary: Exposed steel and aluminum structures found expression as environmental art in a spectacular San Francisco renovation. Three existing office buildings were visually joined with an atrium between them. The centerpiece of the atrium is an 11 story exposed structural framework sculpture known as the Lattice Pavilion. A new hexagonal skylight was installed directly above.

Lundeen, Terry; Perbix, Todd; and Schwartz, John, "Renovation of a Historic Steam Generating Plant for Biotechnical Research Use," *Proceedings of the National Steel Construction Conference*, AISC, Pittsburgh, PA, 1994.

Summary: The Lake Steam Plant was built in three phases from 1914 to 1920, operated by Seattle City Light Company until 1983, and is listed as a historic landmark. The 305 by 90 ft concrete structure with riveted steel trusses is founded on timber piles over the edge of a lake. Renovation consisted of demolition of the heavy concrete main floor and adding 142,000 sq. ft of new floors and roofs. Steel framing was selected for most of the new space because of various project restraints. The new floor system is concrete filled metal deck with composite steel beams. The beams are connected to the concrete columns with high capacity expansion anchors. The trusses were strengthened to accommodate

greater loads. The new lateral bracing system consisted of steel braced frames epoxy anchored to existing columns.

Marquardt, Daniel F. and Levy, Elyse G.,
“Steel Pays Off for Payroll Producer,”
Modern Steel Construction, AISC, January
1999.

Summary: Structural reinforcement made it possible to convert an office building to a facility with heavy live loads. The six-story building utilized a cast-in-place structural system with the “wideslab” floor system. The new usage of the building, for data processing operations and storage of large paper rolls, required live loads more than double the original design loads. To reinforce the existing one-way slab, two steel floor beams were located at the third points of each slab section to create a three-span condition. These beams were supported on girders parallel to the slab span and bolted to the existing concrete columns. Tight headroom required long beam copes and beam web penetrations.

Merovitch, Andrew T., “Seismic Upgrade for A Concrete Frame,” *Modern Steel Construction*, AISC, March 1999.

Summary: Four steel buttress towers were added to a concrete-framed building to bring it up to current standards. The non-ductile five-story concrete frame building was built in Palo Alto the early 1960s. The major deficiencies were a lack of ductility and a lack of column strength. After reviewing many alternatives in both steel and concrete, the decision was made to add four braced steel towers to the exterior. The size of the towers was such that it added 10 percent more usable space to the facility. Light weight, ease of erection, rigidity, ductility, and flexibility for window placement were cited as reasons for the final selection.

Messinger, David L., Cohen, Jeff, and Chun, Kearny, “Strengthening Behind the Scenes,” *Modern Steel Construction*, AISC, January 1991.

Summary: Classified as a “poor seismic risk,” structural strengthening of this 1915 University of California at Berkeley building was necessary to improve its seismic resistance and provide life safety. The steel framed building was built as a square doughnut and had reinforced concrete floors. The exterior granite faced walls were

adequate but the inner court walls were not. The solution was to reinforce the inner walls and tie the perimeter spaces. A diamond shaped bracing system was introduced within the existing steel beams and columns. Tubular sections were used as they were found to be the most efficient steel section and used the least wall space.

McIntyre, Brian, “Renovation Expands Seattle Supersonic’s Home Court,” *Modern Steel Construction*, AISC, September 1997.

Summary: The original Seattle Center Coliseum, built in 1962, was functionally obsolete and deteriorating. The roof, which had leaked from the beginning, was a double-curved hyperbolic paraboloid with aluminum sandwich panels. The retrofit called for replacing the existing roof with a rigid roof matching the original geometry, increased seating capacity, and providing for roof supported rigging loads for shows. It was decided to lower the floor by 35 ft to create a new seating bowl and concourses. For the roof, economical straight steel trusses were used extensively, oriented along the straight-line generators of the original shape, with only four curved trusses. The four main triangular trusses in the original roof spanning 340 ft were saved.

Nelson, Ben, “Gym Infill Requires Structural Strengthening,” *Modern Steel Construction*, AISC, April 1991.

Summary: An athletic center had to be constructed as part of an existing complex but space was limited. The solution was to build about a third of the center on top of an existing pedestrian bridge. Where possible, existing steel beams were strengthened by coverplates added to the bottom flange. Where needed, a WT was welded to the bottom flange instead. Connections of beams to columns were strengthened by adding stiffened seats, adding shear plates, or extending the length of double angle connections. Steel’s flexibility, both in its ability to be readily strengthened and its light weight, resulted in substantial cost savings for the owner.

Peterman, Mark B., “Rebuilding a Landmark,” *Modern Steel Construction*, AISC, February 1996.

Summary: A three-story Texas courthouse built in 1890 was severely damaged by fire. The walls were of load-bearing limestone, the floors of both timber and steel, and the roof framing was

of wood. The fire destroyed the entire roof and attic, much of the third floor, and most of the central portion of the second floor. Of the few steel beams used in the floor framing, most were concrete encased and survived the fire. In the reconstruction effort, the damaged wood floor deck and framing was replaced, using steel beams and bar joists, metal form deck, and a concrete slab. Also, a distinctive tower extending above the roof was framed with steel members.

Popovic, Predrag L., “Structural Repairs and Strengthening of a 360,000 Square Foot Warehouse,” *Proceedings of the National Steel Construction*, AISC, Las Vegas, NV, 1992.

Summary: A single-story, 15-year-old warehouse had experienced numerous roof failures and wall distress. The roof system consisted of roofing supported by steel decking on steel joists that bear on the perimeter masonry walls and steel beam and column framing. Expansion joints were located in the roof and in masonry walls. Inspection and analysis revealed various problems including inadequate lateral resistance of masonry walls and pilasters, inadequate lateral bracing in general, and no lateral support at interior beam-to-column connections. Repairs included the addition of steel vertical wind bracing, modification of expansion joint details, addition of stiffeners, repair of joist defects and reinforcement of pilasters by adding steel columns.

Punch, Steve and Wall, Sidney S., “Constant Growth,” *Modern Steel Construction*, AISC, July 1994.

Summary: Although built only two years ago, rapid growth required a two-floor addition to this hospital near Milwaukee. The addition of one of the floors had been anticipated in the original design. The other was to be floor four in a new multi-story tower. However, the lower floors (as well as the upper floors) were not to be constructed at this time, only the supporting columns for the fourth floor. The floors were designed with composite beam construction, and composite deck with lightweight concrete. Stability was provided by concrete shear walls. To provide fire protection and reduce the slenderness ratio, the long unbraced columns were encased in concrete with blockouts for future connections. However, as the project was nearing completion, it was decided to add nine new floors to the tower. The versatility of steel

made it possible to meet project demands and maintain continuous hospital operations.

Rajagopalan, K. S. and Williams, Robert G., “New Skin Profile Made Possible with Welded Trusses,” *Modern Steel Construction*, AISC, No. 4, 1989.

Summary: The new owner of this 15-story office building charged the design team with (1) creating a new look, (2) stopping water penetration through the curtain wall, and (3) doing the rehab without disrupting daily operations. The building had post-tensioned concrete beams and slabs with reinforced concrete columns. The new profile developed involved moving the plane of the curtain wall forward in line with the projecting pilaster-like covers at the existing columns, thus creating a large eccentricity. In the scheme selected, welded steel box trusses 30 to 36 ft long were erected between the old and new skin, spanning between column pilasters.

Robinson, Keith and Ames, Debbie, “Library Seismic Upgrade,” *Modern Steel Construction*, AISC, January 2000.

Summary: The original 1937 structure was a cast-in-place concrete frame with pan joist floors framing to rectangular concrete girders and columns. The building was clad with granite skirts supported by un-reinforced clay brick. To preserve the existing finishes, the engineers designed an innovative steel shear wall system and strengthened many existing architectural elements. The plates were sized to be lifted by two workers without heavy equipment. With the steel shear wall system, it was possible to avoid relocation of the library contents and keep it open during construction. If concrete had been used, moisture generated by concrete construction could have harmed historic documents. To strengthen inaccessible concrete columns that had weak tension re-bar splices, 40-ft long cores were drilled so that high-strength, threaded reinforcing bars could be installed and post-tensioned to pre-compress the columns.

Roloff, Steven J., “Matching Heights,” *Modern Steel Construction*, AISC, July 1994.

Summary: A vertical addition to a Milwaukee hospital had to match floor-to-floor heights with an adjacent building while accommodating massive mechanical ducts. Three floors were to be added to the existing two-story building while

planning for four more floors in the future. Tight floor-to-floor height restrictions to match adjacent construction complicated the design. Stub-girder systems and deep beams with web cut-outs were investigated but did not prove feasible. Instead, trusses with Vierendeel panels were chosen to accommodate the mechanical requirements. To provide lateral resistance, some of the trusses were included in rigid frames.

Sopko, Stephen J. and Benjamin, Susan, "Vertical Steel Addition Cures Hospital's Space Woes," *Modern Steel Construction*, AISC, July-August 1990.

Summary: A plan was developed to add a four-story vertical addition to an 8-year old steel-framed three-story hospital. The tight site, tight timetable, and need to minimize heights made steel the obvious choice. In one area, the structural system was not adequate to support a vertical expansion, so the addition there had to be cantilevered. The most complicated aspect of the project was incorporating a bracing system to resist wind and seismic forces. A scheme of eccentric compression bracing along with inverted V-bracing was used to avoid mechanical runs, doors, and windows.

Sadeghpour, David H., "Vertical Expansion," *Modern Steel Construction*, AISC, June 1996.

Summary: The owners of an office-garage complex in Houston were faced with a shortage of parking spaces. After reviewing alternatives, it was decided that the most time and cost effective solution would be a vertical expansion. The existing four-story garage was a 1962 cast-in-place concrete frame with single-tee flooring and a double-tier, two-way traffic configuration. After careful analysis it was determined that by strengthening the existing columns and some footings, enough capacity could be acquired to support a six-story steel structure on top of the existing garage. Composite construction with light-weight concrete and metal deck floors was adopted.

Thayer, Gary E. and Rim, Kurt K., "Preserving Cleveland's History," *Modern Steel Construction*, AISC, June 1991.

Summary: The interior of this landmark was completely rebuilt above the second floor to create modern office space. This 12-story 1888 building at one time was the tallest building

between New York and Chicago. After studying alternatives, it was decided remove the entire structure above the second floor while preserving the facade. Although the original columns were shown as circular cast iron sections on the drawings, they were actually built-up steel Z-sections and plates, and nearly equivalent to A36 steel in strength and chemistry. A large transfer truss system was used at the second floor level to reduce the number of columns from 14 to 6. The use of LRFD design for the new floor system saved 12 percent in weight over an initial ASD design.

Thornton, Charles H., Hungsproke, Udom, and DeScenza, Robert P., "Vertical Expansion to Add 235,000 Sq. Ft.," *Modern Steel Construction*, AISC, June 1991.

Summary: This 1906-1913 building is a historic landmark occupying an entire block in New York City. While most of the original building is nine stories and a portion 13 stories, a planned addition would result in a 20-story building. Various changes in design and construction methods over the years made it possible to avoid reinforcing the columns in the lower six floors and enabled this vertical expansion. In the early 1900s the allowable stress was 16 ksi but with present standards, the allowable would be 22 ksi (0.66 x 33 ksi for A7 steel). Also, the current New York City code uses live loads of 50 and 75 psf for certain occupancies instead of the original 125 psf. Further, a live load reduction factor of up to 60 percent is applicable in some areas. The added floors would feature a steel frame with composite slab and metal decking, and new columns located directly above the old ones.

Thornton, Charles H., et al, "Economic Upgrading of Vintage Buildings," *Modern Steel Construction*, AISC, July 1991.

Summary: The structural quality of older buildings often means that major changes in building use, load path or gross square footage, can be accommodated with only minor changes to the structural frame – if the structural engineer understands how to discover the "hidden" capacity of the structure. Two east coast projects are reviewed to illustrate different techniques in the structural rehabilitation of existing buildings. One is a 70-story building constructed in the 1930s in New York's Rockefeller Center, and the second is a 19-story Philadelphia hotel built in 1904.

Timler, Peter A. and Sherstobitoff, John G.,
“Seismic Retrofit for the British Columbia
Institute of Technology,” *Proceedings of the
National Steel Construction Conference*,
AISC, Pittsburgh, PA, 1994.

Summary: The ductile braced, externally mounted steel frame for the seismic retrofit of the four-story BCIT SW1 Main Building presented unique design and erection constraints for both the consultant and steel contractor. The new seismic provisions of the Canadian CAN/CSA-S16.1-M89 code, evoked on the cross-bracing system, incorporated HSS diagonals and wide flange beams and columns providing a member capacity limited frame. As the original structure had significant lateral resistance deficiencies from its overall aspect ratio and construction type, the retrofit limited the deflections of the existing facilities to ensure non brittle performance to the internal lightly reinforced concrete stairwells by absorbing the full effects of the credible earthquake forces. The main structure is part of a four building complex arranged in a rectangular pattern forming a courtyard. The retrofit of these structures used the courtyard as the optimum location for strengthening. Minimizing window coverage and providing a visually unobtrusive retrofit and erectable system within three summer months while meeting the specific ductility requirements for the members and connections necessitated both the design and detailing of all the connections within the frame and to the existing structures by the consultant. Access limitations, coordination of foundation and steel construction schedules, sequence of erection, and some variations between original facilities, design drawings, and actual site conditions presented challenges to the steel contractor in completing the project prior to the Institute’s opening for another semester.

Torrelo, George Jr. and Epstein, Howard I.,
“Composite Action Crucial for Renovation,”
Modern Steel Construction, AISC, May-
June 1990.

Summary: It was necessary to increase the floor live load capacity in the renovation of a hospital department in New Haven. The old floor system was composite construction, but had various deficiencies including two un-bonded slab layers resulting from interrupted concrete placement. Also, the underside of the steel beams was inaccessible. However, using the AISC LRFD Specification, it was determined that the desired

capacity could be obtained by adding 55 new shear studs and tying together two slab layers with 550 shear pins.

Totten, Craig, “Portland Airport Expansion,”
Modern Steel Construction, AISC, January
2000.

Summary: As part of a major airport expansion and renovation, structural steel was selected for a four-level parking garage addition erected over an existing precast concrete structure. According to the author, structural steel was selected because it was lightweight, did not need to be waterproofed, was easy to erect, and esthetically complimented other airport facilities. The use of steel supported the fast-track schedule and was easier to erect than cast-in-place or precast concrete.

Vincent, John F., Corley, Gene, and Kosel,
Hans C., “Do Not Disturb,” *Modern Steel
Construction*, AISC, February 1993.

Summary: A retrofit of an Indiana school’s exterior walls was carried out before and after school hours to minimize disruption. Cracking and displacement were discovered in a 20-year-old southern Indiana school building. The mostly single-story building contained two structural systems: un-reinforced bearing walls with steel roof joists and non-bearing masonry cavity walls with a pre-engineered structural steel frame. An investigation revealed various structural deficiencies including inadequate lateral load resisting systems. The retrofit included the addition of horizontal trusses around the building just above ceiling level to transfer wind-induced reactions from the tops of the walls to the building columns. Also, pilasters were installed along the exterior walls by saw-cutting the brick to create a cavity, bolting steel W sections to the new trusses, and encasing them in concrete.

Ward, Bruce A. and Noel, Paul D., “Adaptive
Reuse Adds Technical Center,” *Modern
Steel Construction*, AISC, December 1995.

Summary: Rather than construct a new building, a Maine paper mill opted to renovate part of an existing mill. The renovation included built-in-place trusses spanning from a wall to new support columns. The trusses were fabricated from WT’s and all connections were welded.

Wathne, John M., "Practical Thermal Prestressing," *Modern Steel Construction*, AISC, February 1996.

Summary: A firm was retained to investigate how to reinforce a heavily loaded roof system for even greater loads. This industrial building had a long span joist roof system and some members were overloaded. Furthermore, it was necessary to reinforce them under load. A system was developed for applying thermally pre-elongated and pre-shortened steel reinforcement to the loaded tension and compression chords and struts, allowing their stresses to equalize with their temperatures. Examples are given of how to apply this principle and various real world problems are discussed.

Wyllie, Loring A.; Dal Pino, John A.; and Cohen, Jeff, "Seismic Upgrade Preserves Architecture," *Modern Steel Construction*, AISC, January 1991.

Summary: University Hall in Berkeley, California underwent major seismic strengthening as part of a general program of seismic upgrades. This was a seven-story concrete framed building constructed in 1957. In the original design, lateral forces were resisted by the exterior perimeter frame and three interior transverse shear walls. The retrofit design called for X-braced steel frames placed within the existing bays of the projecting concrete columns. This system was chosen over others because it was the most economical and created the least disruption to building occupants. Also, some concrete columns with weak ties were strengthened by epoxy bonding steel plates on both sides.

5.2.3 Seismic Retrofit

Anon., "Economic Seismic Connection Repairs: Weld Overlays," *Modern Steel Construction*, AISC, January 1998.

Summary: A new study indicates that earthquake-damaged connections can sometimes be restored to their original condition by depositing a higher-grade weld overlay that resists fracture. The DLW Task Group conducted both small and large-scale tests to verify overall elastic and ductile behavior. Additional tests are planned to extend the proposed repair method to retrofit applications.

Federal Emergency Management Agency (FEMA), *Interim Guidelines: Evaluation, Repair, Modification and Design of Welded Steel Moment Frame Structures*, FEMA 267, August 1995; and *Interim Guidelines Advisory No. 2*, FEMA 267B, June 1999.

Summary: These documents are the first of a series of reports prepared for FEMA by the SAC Joint Venture, a partnership of researchers and practicing engineers from three groups: the Structural Engineers Association of California (SEAOC), the Applied Technology Council (ATC), and the California Universities for Research in Earthquake Engineering (CUREe). FEMA 267B is a supplement and update to FEMA 267; it supercedes an earlier update, FEMA 267A. For recommended criteria from Phase II of the project, see FEMA 350 through 353. This work was instigated by the Northridge, California earthquake of January 17, 1994, in which over 100 steel buildings with welded moment-resisting frames experienced beam-to-column connection fractures. Although the connection fractures did not result in any casualties or collapses, the incidence of damage in regions of strong ground motion caused widespread concern.

FEMA 267 and 267B provide interim guidelines that apply to welded steel moment frame structures subject to large inelastic demands from earthquakes. Included are recommended methods for: "determining which buildings should be subjected to detailed post-earthquake evaluations; developing a program for post-earthquake visual and non-destructive inspections of buildings suspected to have damage; evaluating the effect of discovered damage on residual building safety; identifying appropriate strategies for continued occupancy, structural repair and/or modification of damaged buildings; and designing and constructing new buildings."

The general findings from the FEMA program are stated in FEMA 267B as follows:

"As a result of these and supplemental studies conducted by the SAC Joint Venture, as well as independent research conducted by others, it is now known that a large number of factors contributed to the damage sustained by steel frame buildings in the Northridge earthquake. These included:

- design practice that favored the use of relatively few frame bays to resist lateral seismic demands, resulting in much larger member and connection geometries than had previously been tested;
- standard detailing practice which resulted in the development of large inelastic demands at the beam to column connections;
- detailing practice that often resulted in large stress concentrations in the beam-column connection, as well as inherent stress risers and notches in zones of high stress;
- the common use of welding procedures that resulted in deposition of low toughness weld metal in the critical beam flange to column flange joints;
- relatively poor levels of quality control and assurance in the construction process, resulting in welded joints that did not conform to the applicable quality standards;
- excessively weak and flexible column panel zones that resulted in large secondary stresses in the beam flange to column flange joints;
- large [upward] variations in the strengths of rolled shape members relative to specified values;
- an inherent inability of material to yield under conditions of high tri-axial restraint such as exist at the center of the beam flange to column flange joints.”

“With the identification of these factors it was possible for FEMA 267 to present a recommended methodology for the design and construction of moment-resisting steel frames to provide connections capable of more reliable seismic performance. This methodology included the following recommendations:

- proportion the beam-column connection such that inelastic behavior occurs at a distance remote from the column face, minimizing demands on the highly

restrained column material and the welded joints;

- specify weld filler metals with rated toughness values for critical welded joints;
- detail connections to incorporate beam flange continuity plates, to minimize stress concentrations;
- remove backing bars and weld tabs from critical joints to minimize the potential for stress risers and notch effects and also to improve the reliability with which flaws at the weld root can be observed and repaired;
- qualify connection configurations through a program of full-scale inelastic testing of representative beam-column assemblies, fabricated in the same manner as is proposed for use in the structure;
- increased participation of the design professional in the specification and surveillance of welding procedures and the quality assurance process for welded joints.”

FEMA 267 and 267B are organized into the following chapters:

1. Introduction
2. Definitions, Abbreviations & Notation
3. Classification and Implications of Damage
4. Post-Earthquake Evaluation
5. Post-Earthquake Inspection
6. Post-Earthquake Repair and Modification
7. New Construction
8. Metallurgy & Welding
9. Quality Control/Quality Assurance
10. Visual Inspection
11. Nondestructive Testing
12. References

For the most recent recommendations see FEMA 350 through 353.

Federal Energy Management Agency (FEMA), NEHRP Guidelines for the

Seismic Rehabilitation of Buildings, No. 273, FEMA, Washington, D.C., 1997.

Summary: The systematic seismic rehabilitation of buildings is described in this reference. General requirements are presented and linear and nonlinear analysis procedures are treated. Rehabilitation measures for steel components in particular are reviewed in Chapter 5. Included are a historical perspective, information on material properties and condition assessment, a discussion of the attributes of steel moment frames and braced frames, and engineering properties of diaphragms. Chapters on concrete and masonry are included, and steel frames with concrete or masonry in-fills are discussed. Also included are foundations, wood framing, and light metal framing.

Federal Energy Management Agency (FEMA), *NEHRP Commentary on the Guidelines for the Seismic Rehabilitation of Buildings*, No. 274, FEMA, Washington, D.C., 1997.

Summary: This commentary to the preceding reference provides expanded information on the guidelines for rehabilitation of buildings.

Federal Energy Management Agency (FEMA), *Recommended Seismic Design Criteria for New Moment Resisting Steel Frames*, No. 350, FEMA, Washington, D.C., July 2000.

Summary: This publication presents recommended design and detailing criteria for moment resisting steel frames intended for seismic applications. It is directed at new construction but should be useful in rehab work as well. Chapter 1 provides an introduction as well as the following overview of the remainder of the contents: "Chapter 2: General Requirements. This chapter, together with Chapter 3, is intended to indicate recommended supplements to the building code requirements for design of steel moment-frame buildings. These chapters include discussion of referenced codes and standards; design performance objectives; selection of structural systems; configuration of structural systems; and analysis of structural frames to obtain response parameters (forces and deflections) used in the code design procedures. Also included is discussion of an alternative, performance-based design approach that can be used at the engineer's option, to design for superior or more

reliable performance than is attained using the code-based approach. Procedures for implementation of the performance-based approach are contained in Chapter 4.

Chapter 3: Connection Qualification. Steel moment frames can incorporate a number of different types of beam-column connections. Based on research conducted as part of this project, a number of connection details have been determined to be capable of providing acceptable performance for use with different structural systems. These connections are termed prequalified. This chapter provides information on the limits of this prequalification for various types of connections and specific design and detailing recommendations for these prequalified connections. In some cases it may be appropriate to use connection details and designs which are different than the prequalified connections contained in this chapter, or to use one of the prequalified connection details outside the range of its prequalification. This chapter provides recommended criteria for project-specific qualification of a connection detail in such cases, as well as recommended procedures for new prequalifications for connections for general application. Reference to several proprietary connection types that may be utilized under license agreement with individual patent holders is also provided. When proprietary connections are used in a design, qualification data for such connections should be obtained directly from the licensor.

Chapter 4: Performance Evaluation. This chapter presents a simplified analytical performance evaluation methodology that may be used, at an engineer's option, to determine the probable structural performance of regular, welded steel moment-frame structures, given the site seismicity. These procedures allow the calculation of a level of confidence that a structure will have less than a desired probability of exceeding either of two performance levels, an Immediate Occupancy level or a Collapse Prevention level. If the calculated level of confidence is lower than desired, a design can be modified and reevaluated for more acceptable performance, using these same procedures.

Appendix A: Detailed Procedures for Performance Evaluation. This appendix provides criteria for implementation of the detailed analytical performance evaluation procedures upon which the simplified procedures of Chapter 4 are based. Implementation of these procedures can permit more certain evaluation of the performance of a building to be determined than is possible using the simplified methods of

Chapter 4. Engineers may find the application of these more detailed procedures beneficial in demonstrating that building performance is better than indicated by Chapter 4. Use of these procedures is required when a performance evaluation is to be performed for a building employing connections that have not been prequalified, or for a building that is irregular, as defined in *FEMA-273*.”

Federal Energy Management Agency (FEMA), *Recommended Seismic Evaluation and Upgrade Criteria for Existing Welded Steel Moment-Resisting Frame Construction*, No. 351, FEMA, Washington, D.C., July 2000.

Summary: This publication provides recommendations for methods to evaluate the probable performance of existing steel frame structures in future earthquakes and to retrofit such structures for improved seismic performance. Chapter 1 provides an introduction as well as the following overview of the remainder of the contents:

“Chapter 2: Evaluation Overview. This chapter provides an historic perspective of the development of steel moment-frame design and construction practice in the United States. It also includes discussion of the performance of welded steel moment-frame construction in recent earthquakes and the causes for much of the damage observed in this construction. Guidelines for collection of basic data on the configuration, and the details and materials of construction of a building, needed to conduct an evaluation, are presented, as is a brief introduction into the types of evaluation that may be conducted.

Chapter 3: Performance Evaluation. This chapter presents simplified analytical procedures for determining the probable structural performance of regular, welded, steel moment-frame buildings, given the site seismicity. These procedures allow the calculation of a level of confidence (say, 95%) that an existing structure will achieve a stipulated performance level (e.g., a Collapse Prevention level) for a specified earthquake hazard (e.g., a 2% probability of exceedence in 50 years). If the calculated level of confidence is unacceptably low, then the structure can be upgraded and re-evaluated for more acceptable performance, using these same procedures.

Chapter 4: Loss Estimation. This chapter presents a simplified procedure for estimating the probable post-earthquake repair

costs for existing, welded, steel moment-frame buildings using basic information on the building's configuration and age, and the intensity of ground shaking at the site.

Chapter 5: Seismic Upgrade. This chapter presents recommendations for two approaches to seismic upgrade of existing, welded, steel moment-frame buildings. The first approach, termed simplified upgrade, consists of modification of individual moment-resisting connections to reduce their susceptibility to ground-shaking-induced brittle fracture. The second method is a detailed procedure in which the performance of the structure is first evaluated, using the procedures of Chapter 3, an upgrade approach is conceived and designed in a preliminary manner, and the performance of the upgraded structure is evaluated for acceptability. This process is repeated until a suitable level of confidence of acceptable performance is obtained. Upgrades in this second method may consist of connection upgrades, as in the simplified upgrade approach, but may also include modification of the structural system, such as introduction of braces, or energy dissipation devices.

Chapter 6: Connection Qualification. This chapter presents modeling recommendations and performance data for different types of beam-column connections.

Appendix A: Detailed Procedures for Performance Evaluation. This appendix provides recommendations for the implementation of the detailed analytical performance evaluation procedures upon which the simplified procedures of Chapter 3 are based. Implementation of these procedures can permit more certain evaluation of the performance of a building to be determined than is possible using the simplified methods of Chapter 3. Engineers may find the application of these more detailed procedures beneficial in demonstrating that building performance is better than indicated by Chapter 3. Use of these more detailed procedures is required for the performance evaluation of structures with certain irregularities, as indicated in Chapter 3.

Appendix B: Detailed Procedures for Loss Estimation. This appendix provides procedures for developing building-specific, vulnerability (and loss) functions for steel moment-frame buildings. These vulnerability and loss functions are compatible with *HAZUS*, a nationally applicable computer program developed by FEMA that permits estimation of earthquake losses on a building-specific basis, or community or regional basis. These vulnerability and loss

functions may also be used with other loss-modeling software and methodologies.”

Federal Energy Management Agency (FEMA), *Recommended Post-Earthquake Evaluation and Repair Criteria for Existing Welded Steel Frame Structures*, No. 352, FEMA, Washington, D.C., July 2000.

Summary: This publication provides recommendations for performing post-earthquake inspections to detect damage in steel frame structures following an earthquake, evaluating the damaged structures to determine their safety in the post-earthquake environment, and repairing damaged structures. Chapter 1 provides an introduction as well as the following overview of the remainder of the contents:

“Chapter 2: Inspection and Classification of Damage. This chapter provides an overview of the different types of structural damage that may be anticipated to occur in welded steel moment-frame buildings, together with a discussion of their significance. This chapter also introduces a damage classification system that is referenced throughout the remaining chapters.

Chapter 3: Preliminary Post-earthquake Assessment. This chapter provides screening criteria that can be used to determine if there is sufficient likelihood that a welded steel moment-resisting frame structure has experienced significant damage to warrant further investigation. This Chapter also provides a preliminary evaluation procedure that may be rapidly performed to determine if the building presents imminent safety hazards. Building officials may use the screening criteria to determine which buildings should be subjected to inspections by the Building Department using the Preliminary Evaluation Procedures. While these preliminary evaluation procedures should permit the identification of structures with damage so severe that imminent hazards have been created, they will typically not be sufficient to determine if more moderate levels of damage have occurred. Chapters 4 and 5 provide procedures for more detailed evaluations, necessary to make such determination.

Chapter 4: Level 1 Detailed Post-earthquake Evaluations. Except for those structures that have experienced partial or total collapse, or that exhibit significant permanent interstory drift, the results of a preliminary evaluation conducted in accordance with Chapter 3 are likely to be inconclusive with regard to the post-earthquake condition of the structure. This

chapter provides procedures for conducting more detailed evaluations of the building to confirm its post-earthquake condition and develop recommendations for occupancy and repair of the structure as appropriate. It includes performing inspections of the fracture-susceptible connections in the structure, to determine their condition, and calculation of a damage index. Recommendations for occupancy restriction and repair are provided, based on the calculated value of the damage index. This level of evaluation is too lengthy to be conducted as part of the rapid post-earthquake assessments typically conducted by building departments and is anticipated to be implemented by engineers engaged by the building owner.

Chapter 5: Level 2 Detailed Post-earthquake Evaluations. If a building has experienced many connection fractures, and other types of structural damage, as revealed by a level 1, detailed evaluation, then it may be advisable to restrict occupancy of the building until it can be repaired. Decisions to restrict occupancy can result in a large economic burden, both for the building owner and the tenants and some engineers may be reluctant to advise such action unless analytical evaluation indicates the presence of significant safety hazards. This chapter provides an analytical methodology for estimating the probability of earthquake-induced collapse of a damaged building that can be used to supplement occupancy decisions suggested by the evaluation procedures of Chapter 4.

Chapter 6: Post-earthquake Repair. This chapter provides recommendations for repair of the most common types of damage encountered in welded steel moment-frame construction. It does not include guidelines for structural upgrade. Often, the most logical time to conduct a structural upgrade is during the time that earthquake damage is being repaired. In addition, some jurisdictions require upgrade of buildings that have sustained extensive damage as a matter of policy. Criteria for performing structural upgrade may be found in a companion publication, *FEMA-351 -Recommended Seismic Evaluation and Upgrade Criteria for Existing Welded Steel Moment-Frame Buildings*.

Appendix A: Detailed Procedures for Performance Evaluation. This appendix describes in detail the basis of the reliability-based evaluation methods presented in Chapter 5. It may be used to obtain more certain estimates of structural capacity and must be used for that purpose, instead of the procedures of Chapter 5, for irregular structures.

Appendix B: Sample Placards. This appendix contains sample placards that may be used to post buildings following preliminary post-earthquake evaluations conducted in accordance with Chapter 3 (from ATC, 1995).

Appendix C: Sample Inspection Forms. This appendix contains a series of forms that may be used to record damage detected in beam-column connections as part of a detailed post-earthquake inspection program conducted in accordance with Chapter 4.”

Federal Energy Management Agency (FEMA), *Recommended Quality Assurance Guidelines for Moment-Resisting Steel Frame Construction*, No. 353, FEMA, Washington, D.C., July 2000.

Summary: This publication provides recommendations to engineers and building officials for methods to ensure that steel frame structures are built with adequate construction quality to perform as intended when subjected to severe earthquake loading. It is divided into two parts: Part I – Recommended Specifications and Part II – Quality Assurance Guidelines. As noted in the document, many of the specification recommendations contained in Part I have already been adopted in industry specifications and in building codes. The introduction provides the following overview:

“Part I -Recommended Specifications

Chapter 1: General. This chapter provides definitions for use throughout Part I. It also contains provisions pertaining to submittal of information regarding material, material certifications, procedures, personnel records, quality control plan, and samples. The use of a pre-fabrication, pre-erection conference is also established.

Chapter 2: Products. This chapter lists the applicable material specifications, both generic and specific, for structural steel, welding material, bolting material, and shear connectors.

Chapter 3: Execution. This chapter provides generic and specific recommendations for the fabrication and erection of the structural steel frames, bolting, and welding. Included are several specific recommendations regarding welding operations that are not currently in the welding codes.

Chapter 4: Welded Joint Details. This chapter provides detailing and welding recommendations for specific types of welded joints, including backing bars, weld tabs,

reinforcing fillet welds, weld access holes, web connections, doubler plates, continuity plates, cover-plated connections, welded overlay connections, and haunched connections.

Chapter 5: Fabrication Details. This chapter provides detailing and quality recommendations for steel fabrication, welding, cutting, bolting, and repairs. Quality recommendations for beam-flange-to-column-flange moment-connection welds are provided in this chapter.

Chapter 6: Quality Control and Quality Assurance. This chapter lists governing specifications and practices, the requirements and recommendations for a Written Practice for quality assurance and nondestructive testing, inspector qualifications, nondestructive testing technician qualifications, and a detailed list of quality control and quality assurance tasks for welding, bolting, and shear connector inspection. Specific recommendations for nondestructive testing for various joints are included.

Appendices. Several appendices are provided with details for various recommended test procedures for welding material, welding personnel qualification, and nondestructive testing technician qualification. Recommended provisions for magnetic particle testing procedures are also provided.

Part II - Quality Assurance Guidelines

Chapter I: General. This chapter provides discussion of various terms relating to the process of ensuring that workmanship and materials conform to the applicable standards. In addition it describes the various phases of the quality process and the recommended role of various participants in these phases.

Chapter 2: Contractor Qualifications and Quality Tasks. This chapter describes methods for determining whether contractors have adequate qualifications to perform the work, and also provides recommended contractor responsibilities in the quality process.

Chapter 3: Quality Assurance Agency Qualifications and Quality Assurance Tasks. This chapter describes methods for determining whether inspection agencies and testing laboratories that perform quality control and assurance tasks, and their personnel engaged in these tasks, have adequate qualifications for this work. It also includes recommendations for inspection agency work scope as part of the quality process.

Chapter 4: Structural Steel. This chapter provides recommendations for procedures to ensure that structural steel materials meet the applicable standards. Checklists for assisting in the verification of steel quality are included.

Chapter 5: Welding. This chapter presents recommended methods for ensuring that welded joints meet the applicable materials and workmanship standards. Included in this chapter is a description of the basis for determining the quality assurance category for a welded joint, used in Part I of these *Recommendations* as an index to recommended quality assurance measures.

Chapter 6: Bolting. This chapter presents recommended procedures for determining whether bolted joints meet the applicable materials and workmanship requirements.”

Federal Energy Management Agency (FEMA), *Recommended Specifications for Moment-Resisting Steel Frames for Seismic Applications*, No. 354, FEMA, Washington, D.C., July 2000.

Summary: This guideline specification provides engineers, building officials, inspectors and contractors with a uniform series of specifications for the construction of moment-resisting steel frames designed for resistance to earthquake ground shaking.

Federal Emergency Management Agency (FEMA), *Seismic Evaluation & Upgrade Criteria for Existing Welded Steel Moment-Resisting Frame Structures*, SAC Joint Venture Report No. SAC-2000-02-b, Sacramento, CA, 2000.

Summary: This publication was written in response to the 1994 Northridge Earthquake. The intent is to provide engineers and building officials with guidelines for evaluating the probable earthquake performance of existing buildings and structures of welded moment-resisting steel frame (WMSF) construction and for designing upgrades to such structures to improve their probable performance.

Gross, John L., Englehardt, Michael D., Uang, Chia-Ming, Kasai, Kazuhiko, and Iwankiw, Nestor R., “Modification of Existing Steel Welded Moment Frame Connections for

Seismic Performance,” *Design Guide No. 12*, AISC, 1999.

Summary: Guidance is provided for the rehabilitation of existing welded steel moment frame buildings to improve their seismic resistance in future earthquakes. Retrofit concepts with reduced beam section, welded haunch, and bolted bracket modifications are presented. The modification alternatives resulted from a joint research effort between the National Institute for Science and Technology and AISC.

Richard, Ralph M., Allen, C. Jay, and Partridge, James E., “Proprietary Slotted Beam Connection Designs,” *Modern Steel Construction*, AISC, March 1997.

Summary: After comprehensive elastic, plastic, and buckling analyses using finite element models coupled with testing, a proprietary beam-to-column connection was developed for new construction or retrofit. The connection features horizontal beam web slots near the flanges, a welded and bolted single plate shear tab, and a beam web to column flange weldment. The stress concentration factor at the beam-to-column interface is reduced from about 5 to a typical value of 1.4. The design allows beam flanges and the web to buckle independently and circumvent distress from lateral-torsional buckling. The connections were used in a 20-story building in Salt Lake City.

Simon, Warner et al, “Repair of Existing Steel Moment Frame Buildings Damaged from Earthquakes Using Fracture Tough Weld Overlays,” *Engineering Journal*, Vol. 36, No. 4, AISC, 1999.

Summary: This paper reports the first phase of a research and testing effort by a volunteer group of metallurgists, structural engineers, testing engineers, and welding engineers who have developed methods of repairing existing earthquake damaged steel moment frame connections using fracture tough weld overlays. This work was inspired by the well-reported damage to steel moment frame buildings observed following the January 17, 1994 Northridge Earthquake. Subject to more research and testing, the methods may eventually prove suitable for modification of existing steel moment frame buildings and new construction, along with application in other industries.

Uang, Chia-Ming and Bondad, Duane,
“Improving the Seismic Performance of Pre-Northridge Steel Moment Frame Connections with Haunches,” *Proceedings of the National Steel Construction Conference*, AISC, Phoenix, AZ, 1996.

Summary: The 1994 Northridge earthquake resulted in unexpected damage to steel frame buildings. Four identical full-size moment connections (UCSD-1, UCSD-3, UCSD-4, and UCSD-5), which were designed and constructed per pre-Northridge practice, were tested cyclically at the University of California, San Diego. Specimens UCSD-1 and UCSD-3 were tested statically per ATC-24 testing protocol. Both specimens failed in the flange groove welded joint, either in the top or bottom flange. Significant panel zone yielding was observed. Specimens UCSD-4 and UCSD-5 were tested dynamically in order to simulate the loading rate effects. Again, the beam flange groove-welded joint fractured; the beam web shear plate also suffered significant damage. The plastic rotation capacities fell in the lower range of those tested statically. Unlike UCSD-1 and UCSD-3, the fractures propagated into the column flange for the two dynamically tested specimens, which made them more difficult to repair. All four damaged specimens were repaired with a triangular haunch on the bottom flange and retested, either statically or dynamically. The repaired specimens performed much better than the previous specimens and succeeded in pushing the beam plastic hinging outside of the haunch.

Weissberg, Stephen M.; Van Volkinburg, David R.; Mayes, Ronald L.; and Jones, Lindsay R., “An Alternative for Earthquake Design,” *Modern Steel Construction*, AISC, January 1991.

Summary: A seismic isolation system provides an economical alternative for the seismic design of new structures or the rehabilitation of existing buildings and other structures. Basic system elements include (1) a flexible support (spring) so that the fundamental period of vibration is lengthened sufficiently to reduce the force response, (2) a damper or energy dissipator to limit the relative deflections across the flexible support to a practical level, and (3) rigidity at low (service) load levels. These elements are discussed as well as economic considerations including construction costs, earthquake insurance, and the effect of business disruption.

Wolfe, John; Mar, David; and Tipping, Steve,
“Propped Shear Walls,” *Modern Steel Construction*, AISC, January 2001.

Summary: A propped shear wall is a unique steel and concrete lateral bracing system for retrofit seismic strengthening of existing buildings, which combines friction damping with the best aspects of steel braces and concrete shear walls. It consists of a tall slender concrete shear wall that is propped with braces that extend diagonally from a point near the top of the shear wall to ground level. During large earthquakes, the slotted bolted friction connections of the steel props, along with flexural yielding at the base of the shear wall, provide seismic energy dissipating mechanisms. This article describes several recent applications of the system, which has been used for twenty buildings in the San Francisco Bay area.

Xue, Ming; Kaufmann, Eric J.; Lu, Le-Wu; and Fisher, John W., “Achieving Ductile Behavior of Moment Connections,” Part I, *Modern Steel Construction*, AISC, January 1996; Part II, *Modern Steel Construction*, AISC, June 1996.

Summary: As part of the research resulting from the 1994 Northridge earthquake, five full scale beam-to-column moment connections were tested. The results provided confirmation that ductile behavior can be achieved in welded moment connections if electrodes with mandatory toughness requirements are used and detailing is improved. Connections with fractured beam flange welds can be repaired by removing the damaged welds and re-welding with tougher electrodes. Bolted shear tabs reinforced with fillet welds behave similar to a fully welded web.

Zekioglu, Atila, et al “Designing After Northridge,” *Modern Steel Construction*, AISC, March 1997.

Summary: As a result of the 1994 Northridge earthquake, connections in steel moment resisting frames were redesigned before construction to enhance seismic performance. It was decided to use a reduced beam flange area near the columns by flame cutting a tapered profile. Welded web shear plates and rib plates between the beam and column flanges were also used. The results of several large-scale tests and finite element correlations are described. The

connections were used for a four-story hospital building in Los Angeles County.

Also see the following references to seismic rehab under 5.2.2, Case Studies:

Andrews, William A., “Renovating for the Future,” *Modern Steel Construction*, AISC, January 1991.

Anon., “Pacific Place, San Francisco, California,” *Modern Steel Construction*, AISC, March 2000.

Anon., “Bombs Away,” *Modern Steel Construction*, AISC, February 1998.

Anon., “Renovation Without Disruption,” *Modern Steel Construction*, AISC, March 1992.

Fierro, Eduardo; Perry, Cynthia L.; and Varner, Thomas R., “Damping System Aids Seismic Retrofit,” *Modern Steel Construction*, AISC, July 1992.

Greco, Adam, “Renovation Creates New Landmark,” *Modern Steel Construction*, AISC, December 1997.

Kouyoumdjian, Hratch, “Renovating Concrete,” *Modern Steel Construction*, AISC, March 1999.

Merovitch, Andrew T., “Seismic Upgrade for A Concrete Frame,” *Modern Steel Construction*, AISC, March 1999.

Messinger, David L., Cohen, Jeff, and Chun, Kearny, “Strengthening Behind the Scenes,” *Modern Steel Construction*, AISC, January 1991.

Robinson, Keith and Ames, Debbie, “Library Seismic Upgrade,” *Modern Steel Construction*, AISC, January 2000.

Sopko, Stephen J. and Benjamin, Susan, “Vertical Steel Addition Cures Hospital’s Space Woes,” *Modern Steel Construction*, AISC, July-August 1990.

Timler, Peter A. and Sherstobitoff, John G., “Seismic Retrofit for the British Columbia Institute of Technology,” *Proceedings of the National Steel Construction Conference*, AISC, Pittsburgh, PA, 1994.

Timler, Peter A. and Sherstobitoff, John G., “External Bracing Provides Seismic Support,” *Modern Steel Construction*, AISC, 1995. (No summary, similar to above “Seismic Retrofit for the British Columbia Institute of Technology”.)

Wyllie, Loring A.; Dal Pino, John A.; and Cohen, Jeff, “Seismic Upgrade Preserves Architecture,” *Modern Steel Construction*, AISC, January 1991.

Appendix A1

HISTORICAL REVIEW OF AISC SPECIFICATIONS – 1923 TO 1999

Table A1 provides a chronology of the various editions of AISC specifications and supplements thereof. A description of the changes made in the various revisions follows. No attempt is made to explain the specification revisions. Symbols used are not always defined but should generally be

intuitive. Reference should be made to the original specifications for complete details of the changes. Developments through 1978 were taken from a detailed set of notes compiled by the late Frank W. Stockwell, Jr.

Table A1
Chronology of AISC Specification Development

Date	Action
A. ASD Specifications	
June 1, 1923	Adopted first <i>Specification</i>
Nov. 1, 1928	Revision
Jan. 1934	Revision
June 1936	Revision
June 1937	Revision (Editorial)
July 1941	Revision
Feb. 1946	Revision
June 23, 1949	Revision
Nov. 30, 1961	New version with major reorganization.
Apr. 17, 1963	Revision
Feb. 12, 1969	Revision
Nov. 1, 1970	Adopted Supplement No.1 to 1969 <i>Specification</i>
Dec. 8, 1971	Adopted Supplement No.2 to 1969 <i>Specification</i>
June 12, 1974	Adopted Supplement No.3 to 1969 <i>Specification</i>
Nov. 1, 1978	Revision
March 11, 1986	Adopted Supplement No. 1 to 1978 <i>Specification</i>
January 1, 1989	Adopted Supplement No. 2 to 1978 <i>Specification</i>
June 1989	Revision
B. LRFD Specifications	
September 1, 1986	Adopted first LRFD <i>Specification</i>
January 1, 1989	Adopted Supplement No. 1 to 1986 <i>Specification</i>
December 1, 1993	Adopted second LRFD <i>Specification</i>
January 30, 1998	Adopted Supplement No. 1 to 1993 <i>Specification</i>
December 27, 1999	Adopted third LRFD <i>Specification</i>

June 1,1923 Adoption of first specification.

November 1,1928 Revision

SECTION 5. ALLOWABLE STRESSES

(a) Tension. Added second paragraph on rivets (13,500 psi allowable).

SECTION 13. RIVETS AND BOLTS

Added paragraph (e).

SECTION 20. WORKMANSHIP

Revised paragraph (g) on riveting and (i) on flame cutting.

SECTION 21. PAINTING

(a) Added "riveted surfaces shall not be painted."

January 1934 Revision

SECTION 3. MATERIAL

Added A7 steel for bridges.

SECTION 5. ALLOWABLE STRESSES

(d) Shearing. Changed definition of "h" to clear distance between flanges

SECTION 7. BEAMS AND GIRDERS

Revised paragraph (c) on web splices.

SECTION 8. COLUMN BASES

Revised paragraph (b).

SECTION 12. NET SECTIONS

Clarified paragraph (b).

SECTION 15. CONNECTIONS

Revised minimum number of rivets (a) and reworded paragraph (e).

SECTION 16. LATTICE

Reworded paragraph (c).

SECTION 19 .ADJUSTABLE MEMBERS

Reworded section.

SECTION 20. WORKMANSHIP

Reworded paragraph (g) on rivets and paragraph (h) on compression joints.

June 1936 Revision

The format was changed, dividing the specification into eight separate Parts with 28 Sections. Many sections were reorganized, renumbered, rearranged and reworded for clarity. However, sections are not listed below unless they were new or significantly revised.

SECTION 2. PLANS AND DRAWINGS

New section taken in part from the Code of Standard Practice.

SECTION 3. MATERIAL

(b) Rivet Steel. Specified ASTM A141

(c) Other Metals. Added section for ASTM metals

(d) Stock Material. New section regarding classification.

SECTION 6. COMBINED STRESSES

(a) Axial and Bending. Introduced the interaction formula, $\frac{f_a}{F_a} + \frac{f_b}{F_B} \leq 1$.

(b) Rivets. New paragraph.

(c) Wind and other Forces. Clarified 33-1/3% increase from Section 5 (f) of the previous specification.

SECTION 8. COMPOSITE BEAMS

New section permitting composite behavior for beams with top (compression) flanges encased.

SECTION 9. EFFECTIVE SPAN LENGTH

New section covering (a) simple spans and (b) end restraint.

SECTION 10. ALLOWABLE UNIT STRESSES

(a) Structural Steel and Rivet Steel.

Tension. Structural Steel from 18,000 to 20,000
Rivets from 13,500 to 15,000

Compression. For $l/r < 120$ $F_a = 17,000 - 0.485 \frac{l^2}{r^2}$
For $l/r > 120$ $F_a = \frac{18,000}{1 + \frac{l^2}{18,000r^2}}$

Added 20,000 psi for plate girder stiffeners and 24,000 psi for toe of fillet, rolled section webs.

Bending. Increased maximum allowable stress from 18,000 to 20,000 psi.
Revised allowable for lateral buckling to

$$F_b = \frac{22,500}{1 + \frac{l^2}{1800b^2}} \text{ for } l/b < 40.$$

Pin allowable stress, increased from 27,000 to 30,000 psi.

Shearing. Rivets etc. in reamed holes, increased from 13,500 to 15,000 psi.
Webs of beams and plate girders, increased from 12,000 to 13,000 psi.

Bearing. Allowable bearing values (except for expansion rollers and rockers) increased by 20 to 33-1/3%.

(b) Cast Steel. Compression and Bending as above; other stresses 75% of allowable for Structural Steel

(c) Masonry. New section added, "Bearing," giving allowable bearing values for various types of masonry.

SECTION 11. SLENDERNESS RATIO

Graph added showing F_a vs. l/r for axially loaded columns.

SECTION 12. UNSUPPORTED COMPRESSION FLANGES

(a) Tabulated F_b for values of $l/b \geq 40$ (per Sect. 10a).

SECTION 16. CONNECTIONS

Two new paragraphs on (e) Restrained Members and (g) Splices.

SECTION 17. RIVETS AND BOLTS

(e) Use of rivets -specified cases where rivets must be used (e.g., column splices in all tier structures 200 feet or more in height).

SECTION 18. RIVET SPACING

(f) New paragraph on minimum edge distances.

SECTION 19. PLATE GIRDERS AND ROLLED BEAMS

Extensive revision; significant changes as follows:

Plate girder web, minimum thickness from $h/160$ to $h/170$.

Stiffener requirement, from $h/t = 60$ to $h/t = 70$.

Stiffener spacing changed to $d = \frac{270,000t}{v} \sqrt[3]{\frac{vt}{h}} \leq 84$ in.

(h) Web Crippling of Beams. New paragraph introducing following limits for compressive stress at concentrated loads:

$$\text{Interior Loads} \quad \frac{R}{t(N + 2k)} \leq 24,000 \text{ psi}$$

$$\text{End Reactions} \quad \frac{R}{t(N + k)} \leq 24,000 \text{ psi}$$

SECTION 24. ANCHOR BOLTS

New one-sentence section.

SECTION 25. WORKMANSHIP

All references to hand-driven rivets (obsolete) were dropped.

SECTION 27. ERECTION

Two new paragraphs were added on (f) Turned Bolts and (g) Field Painting.

June 1937 **Revision (Editorial)**

July 1941 **Revision**

SECTION 1.

(a) Added definition of "Structural Steel."

SECTION 3. MATERIAL

Deleted ASTM A9 Steel.

SECTION 4.

Clarified paragraph (d), Impact, and added paragraph (e), Crane Runways.

SECTION 10.

(a) Added allowable tension (12,000 psi) for bolts, etc.

SECTION 11.

Added $l/r = 300$ limit for tension members other than rods.

SECTION 12. DEPTH RATIOS

New section added giving limits for depth of beams for (a) Simple Spans and (b) Restrained and Continuous Spans.

SECTION 14. MINIMUM THICKNESS OF MATERIAL

(a) Main Members. Paragraph revised
(c) Flanges. New paragraph.
Deleted paragraphs (c) Angles and (e) Corrosion.

SECTION 16. EXPANSION

Added coefficient of expansion for structural steel (0.0000065/ °F/ unit length).

SECTION 18. RIVETS AND BOLTS

Added new paragraph (c) on Double and Single Shear Bearing and deleted paragraph (g) on Main Members.

SECTION 21. SEPARATORS

New section for separators tying two or more beams together.

SECTION 24. CAMBER

New section on truss, beam and girder camber requirements, incorporating provisions of previous Section 22, Adjustable Members.

February 1946 Revision

The format was changed from eight to five Parts with 34 Sections. Most changes were caused by the introduction of welding. Major changes were as noted below.

SECTION 1. TYPES OF CONSTRUCTION

Defined three basic types of construction -Type 1, Rigid Frame; Type 2, - Simple Framing; Type 3, Semi-Rigid Framing

SECTION 2. DEFINITIONS AND NOMENCLATURE, WELDED CONSTRUCTION

New section.

SECTION 3. PLANS AND DRAWINGS

Revised first part of section and added (c) Notations for Welding and (d) Symbols for Welding, referenced to A.W.S.

SECTION 5. WELDING

New section including paragraphs (a) Welding and (b) Rivets and Bolts Used in Combination with Welds.

SECTION 6. TURNED BOLTS

New section with shank and hole requirements specified as well as tolerance and head requirements per American Standard B 18.2-1941.

SECTION 7. ERECTION

(e) Where previous specification required rivets under certain conditions (e.g. column splices in tier buildings over 200 ft.), revised to permit welds as alternate.
(g) New section, Field Welding.

SECTION 9. MATERIAL

(e) New section, Filler Metal.

SECTION 11. MEMBERS SUBJECT TO REVERSAL OF STRESS

Revised and introduced Cyclic Loading.

SECTION 12. COMBINED STRESSES.

Provisions for Shear with Tension or Compression expanded to include welds.

SECTION 15. ALLOWABLE UNIT STRESSES

(a) Structural Steel, Rivets, Bolts and Weld Metal.

Tension. Increased allowable stresses for rivets (15,000 to 20,000 psi) and Bolts and Other Threaded Parts (12,000 to 20,000 psi).

Added allowable stress for fillet welds (20,000 psi through throat).

Compression. Added butt welds (20,000 psi through throat).

Bending. Allowable stresses for rolled sections, plate girders, and built-up members:

$$\frac{ld}{bt} \leq 600 \quad F_b = 20,000 \text{ psi}$$

$$\frac{ld}{bt} > 600 \quad F_b = \frac{12,000,000}{\frac{ld}{bt}} \text{ psi}$$

Added increase in allowable stress (20%) over supports for continuous beams.

Added $F_b = 24,000$ psi for column subjected to axial and bending stresses.

Shearing. Added values for fillet, plug or slot, and butt welds.

Bearing. Added (f) Effective Areas of Weld Metal.

SECTION 16. SLENDERNESS RATIO

Main compression members.

Upper limit of l/r was changed from 120 to 200, provided that f_a does not exceed

$$F_a \text{ (from 15 (a) 1) times } 1.6 - \frac{l}{200r}.$$

Plot of F_a vs. l/r deleted.

Tension members other than rods. $l/r = 300$ was revised to $l/r = 240$ for main members and $l/r = 300$ for bracing and secondary members.

SECTION 17. DEPTH RATIOS

Revised to include (c) Secondary Tension Members.

SECTION 18. MINIMUM THICKNESS OF MATERIAL

Revised sections (c) Projecting Elements Under Compression and (d) Compression Members.

SECTION 21. CONNECTIONS

Minimum Connections. Revised to include bolting and welding.

(c) Placement of Rivets and Welds. Added weld provisions.

(d) Unrestrained Members. Added horizontal displacement formulas:

$$e = 0.007d \quad \text{or} \quad e = fL/3,625,000$$

SECTION 23. SPACING OF RIVETS

Minimum pitch revised to 3 times rivet diameter.

SECTION 24. WELDS

New sections added as follows: Types of Welds, Qualification of Weld Details, Minimum Size of Fillet Welds, Maximum Effective Size of Fillet Welds, Length of Fillet Welds, End Returns of Fillet Welds, and Plug and Slot Welds.

SECTION 25. SPACING OF WELDS

New section added as follows: Longitudinal Fillet Welds, Intermittent Fillet Welds, Lap Joints, Slot Welds, and Stitch Welds.

SECTION 26. PLATE GIRDERS AND ROLLED BEAMS

Section extensively revised; welded plate girders were included.

(e) Stiffeners. Where $h/t \geq 70$, intermediate stiffeners required at all points where

$$\frac{h}{t} = \frac{8000}{\sqrt{v}}.$$

$$\text{Revised spacing, } d = \frac{11,000t}{\sqrt{v}} \leq 84 \text{ in.}$$

$$\text{Added } I_s = 0.00000016h^4.$$

SECTION 29. LACING

Deleted previous specification paragraph (c) Minimum Properties and added paragraph (d) Perforated Cover Plates.

SECTION 30. CAMBER

Deleted paragraph (f) Initial Stress.

SECTION 33. WORKMANSHIP

Deleted section (c) Heating, and added (h), (l), (m), and (n), all on workmanship related to welded construction.

SECTION 34. SHOP PAINTING

Added (e) Surfaces to be Field Welded.

SECTION 35. ADMINISTRATIVE PROVISIONS

New section added.

June 23, 1949 Revision

SECTION 18. MINIMUM THICKNESS OF MATERIAL

Deleted minimum thickness requirements for interior members and revised requirements for exterior steelwork.

November 30, 1961 New version with major reorganization

The *Specification* was organized into Part 1, covering traditional allowable stress design, and Part 2, covering plastic design. A *Commentary* was included for the first time, which included design aids for C_m and K values. Also, an appendix was added that listed constants for $F_y = 33,000$ psi to $F_y = 50,000$ psi as well as tables for F_a , F_e' and h/t vs. a/h for stiffeners.

Major revisions included in Part 1 were as follows:

SECTION 1.4 MATERIAL

- 1.4.1 Structural Steel. Added ASTM A373, A36, A440, A441, and A242.
- 1.4.2 Other Metals. Added ASTM A27 (Grade 65-35), A148 (Grade 80-50), A235 (Class C1, F and G), and A237 (Class A).
- 1.4.3 Rivets. Added ASTM A191 and A406.
- 1.4.4 Bolts. Added ASTM A325, A354 (Grade BC) and A307.
- 1.4.5 Filler Metal for Welding. Electrode classification extended to include E70 series of ASTM A233

SECTION 1.5 ALLOWABLE UNIT STRESSES

All formulas were revised and expressed as a function of F_y .

1.5.1.1 Tension. $F_t = 0.60 F_y$ or $0.45 F_y$ (pin holes, etc.).

1.5.1.2 Shear. $F_v = 0.40 F_y$

1.5.1.3 Compression. Introduced Formulas (1), (2) and (3):

$$\text{when } l/r < C_c \quad F_a = \frac{\left[1 - \frac{(l/r)^2}{2C_c^2} \right] F_y}{\frac{5}{3} + \frac{3(l/r)}{8C_c} - \frac{(l/r)^3}{8C_c^3}} \text{ psi} \quad (1)$$

$$\text{where } C_c = \sqrt{\frac{2\pi^2 E}{F_y}}$$

$$\text{when } l/r > C_c \quad F_a = \frac{149,000,000}{(l/r)^2} \text{ psi} \quad (2)$$

$$\text{Bracing, etc., when } l/r > 120 \quad F_{as} = \frac{F_a}{1.6 - \frac{l}{200r}} \quad (3)$$

Gross area of plate girder stiffeners. $F_a = 0.60 F_y$

Web of rolled shapes at toe of fillet. $F_a = 0.75 F_y$

1.5.1.4 Bending. Introduced the compact section for which $F_b = 0.66F_y$ and allowed a 10% moment redistribution.

Basic bending stress $F_b = 0.60F_y$.

Added Formula (4) below (Formula 5 was in previous specification). Use larger of (4) and (5) but not more than $0.60F_y$.

Neglect (4) when $l/r < 40$.

$$F_b = \left[1.0 - \frac{(l/r)^2}{2C_c^2 C_b} \right] 0.60F_y \quad (4)$$

where the bending coefficient is

$$C_b = 1.75 - 1.05 \left(\frac{M_1}{M_2} \right) + 0.3 \left(\frac{M_1}{M_2} \right)^2 \leq 2.3$$

$$F_b = \frac{12,000,000}{ld / A_f} \quad (5)$$

1.5.1.5 Bearing. Allowable listed in terms of F_y .

1.5.2 Rivets and Bolts. Stresses tabulated in Table 1.5.2.1. For the first time, the specification reflected a one for one substitution of high-strength bolts for rivets.

1.5.3 Welds. Added 15,800 allowable for E70 electrodes.

1.5.5 Masonry Bearing. Revised for bearing on concrete:

$$\text{On full area of support} \quad F_p = 0.25f'_c$$

$$\text{On one-third area} \quad F_p = 0.375f'_c$$

SECTION 1.6 COMBINED STRESSES

1.6.1 Axial Compression and Bending. Revised formulas to include a bending

coefficient, C_m , and an amplification factor, $1 - \frac{f_a}{F'_e}$.

$$\text{When } f_a / F_a \leq 0.15 \quad \frac{f_a}{F_a} + \frac{f_b}{F_b} \leq 1.0 \quad (6)$$

$$\text{When } f_a / F_a > 0.15 \quad \frac{f_a}{F_a} + \frac{C_m f_b}{\left(1 - \frac{f_a}{F'_e} \right) F_b} \leq 1.0 \quad (7a)$$

$$\text{And at braced points} \quad \frac{f_a}{0.60F_y} + \frac{f_b}{F_b} \leq 1.0 \quad (7b)$$

1.6.2 Shear and Tension. A major revision specifying interaction formulas for F_t and F_v for fasteners.

SECTION 1.7 MEMBERS & CONNECTIONS SUBJECT TO REPEATED VARIATION OF STRESS

Rules were expanded to cover four different cyclic ranges: to 10,000; 10,000 to 100,000; 100,000 to 2,000,000; and over 2,000,000.

SECTION 1.8 SLENDERNESS RATIOS

Revised to distinguish between *sidesway prevented* and *sidesway permitted*. The $l/r < 120$ restriction dropped for main compression members (Section 1.5.1.3).

SECTION 1.9 WIDTH-THICKNESS RATIOS

Limits revised and listed as a function of $\sqrt{F_y}$.

SECTION 1.10 PLATE GIRDERS AND ROLLED BEAMS

1.10.2 Web. Minimum web thickness liberalized

$$d \leq \frac{14,000,000}{\sqrt{F_y}(F_y + 16,500)} t$$

1.10.5 Stiffeners. Provisions liberalized to recognize tension field action (post-buckling strength or truss effect). Web shear limited to:

$$\text{when } C_v < 1.0 \quad F_v = \frac{F_y}{2.98} \left[C_v + \frac{1 - C_v}{1.15\sqrt{1 + (a/h)^2}} \right] \quad (8)$$

$$\text{when } C_v > 1.0 \quad F_v = \frac{F_y}{2.98} C_v < 0.4F_y \quad (9)$$

where C_v is a defined function of critical web stress.

Formula (10) added for stiffener area required for tension field action.

1.10.6 Reduction in Flange Stress.

Formula (11) added for flange stress reduction caused by portion of web in compression.

1.10.7 Combined Shear and Tension Stress.

Formula (12) added to limit tensile bending stress.

SECTION 1.11 COMPOSITE CONSTRUCTION

For the first time, shear connectors were recognized for composite construction, in addition to beam encasement. Formulas were added for S_{tr} , section modulus limit (transformed composite section) for construction without temporary shoring, and V_h , shear force to be resisted by shear connectors. Table 1.11.4 for various connector types.

SECTION 1.14 GROSS AND NET SECTIONS

Added 1.14.7 covering Effective Areas of Weld Metal.

SECTION 1.15 CONNECTIONS

Revised previous section and added the following new sections:

1.15.10 Rivets and Bolts in Combination with Welds

1.15.11 High-Strength Bolts (in Friction-Type Joints) in Combination with Rivets

1.15.12 Field Connections. A rewrite of previous specification Section 7 (e) with high-strength bolts added.

SECTION 1.17 WELDS

Added two new sections :

- 1.17.1 Welder and Welding Operator Qualifications
- 1.17.3 Submerged Arc Welding

SECTION 1.20 EXPANSION

Exact provisions regarding expansion were dropped and replaced with one, simple statement: "Adequate provision shall be made for expansion and contraction appropriate to the service conditions of the structure."

SECTION 1.23 FABRICATION

Added Table 1.23.6 on Minimum Preheat and Interpass Temperatures and added provisions for high-strength bolting.

SECTION 1.24 SHOP PAINTING

For the first time, steelwork to be concealed by interior building finish "need not be painted."

PART 2

For first time the Specification permitted plastic design for one and two-story rigid frames (Type 1 Construction). Part 2 was organized into the sections listed below.

SECTION 2.1 SCOPE

Load Factors were defined as follows:

- Simple and Continuous Beams, Live Loads and Dead Loads: 1.70
- Continuous Frames, Live Loads and Dead Loads: 1.85
- Continuous Frames, Wind and Seismic Forces: 1.40

SECTION 2.2 STRUCTURAL STEEL

Limited to A7, A373 and A36 steels.

SECTION 2.3 COLUMNS

SECTION 2.4 SHEAR

SECTION 2.5 WEB CRIPPLING

SECTION 2.6 MINIMUM THICKNESS (WIDTH-THICKNESS RATIOS)

SECTION 2.7 CONNECTIONS

SECTION 2.8 LATERAL BRACING

SECTION 2.9 FABRICATION

April 17, 1963 Revision

This was a minor revision that included editorial changes for clarity.

SECTION 1.5 ALLOWABLE UNIT STRESSES

- 1.5.1.3 Compression. K factors were inserted into formulas (1) and (2).
- 1.5.1.4 Bending. Definition of Compact Sections clarified in first paragraph.
- 1.5.4. Case Iron and Steel Forgings. Revised to be consistent with Section 1.5.1

SECTION 1.6 COMBINED STRESSES

- 1.6.1 Axial Compression and Bending. K inserted in definition of F_e' .
- 1.6.2 Axial Tension and Bending. New section added.

SECTION 1.8 SLENDERNESS RATIOS

Added K factors where appropriate

SECTION 1.13 DEFLECTIONS

Beam depth for flat roofs changed from $F_y/1,000,000$ times span length to $f_b/600,000$ times span length.

SECTION 2.3 COLUMNS

Formula (23) for single curvature was revised.

SECTION 2.5 WEB CRIPPLING

Editorial revisions for clarity and a formula for minimum web stiffener area, A_{st} , added.

APPENDIX

Modified to reflect specification changes.

February 12, 1969 **Revision**

This major revision included changes in formula constants because of standardization of units in kips and kips per square inch (ksi). Formulas were renumbered to reflect location in the *Specification*.

SECTION 1.4 MATERIAL

- 1.4.1 Structural Steel. Two steels were deleted, A7 and A373. Nine steels were added including A572, A588, and A514 steels. The latter plate steel extended the range of specified minimum yield stresses to 100 ksi. ASTM listings were also revised for Other Metals (1.4.2) and Rivets (1.4.3).
- 1.4.4 Bolts. A354 was deleted and A449 and A490 were added.
- 1.4.5 Filler Metal for Welding. Extensively revised to accommodate the changes in steels.

SECTION 1.5 ALLOWABLE STRESSES

- 1.5.1.4 Bending. Definition of Compact Section was clarified from a parenthetic statement to one meeting specific criteria (1.5.1.4.1- paragraphs "a" through "e").
- 1.5.1.4.2 Transition formula (1.5-5) was added.
- 1.5.1.4.3 Minor axis bending increased to $0.75F_y$.
- 1.5.1.4.6a Formula (4) for lateral buckling strength of beams was replaced by two expressions (1.5-6a) for $0.33F_y < F_b < 0.60 F_y$ and (1.5-6a) for $F_b < 0.33 F_y$.
- 1.5.2 Rivets, Bolts and Threaded Parts. Table 1.5.2.1 was revised.
- 1.5.3 Welds. Table 1.5.3 was added listing welding stresses relative to electrodes used and Matching Base Metal. Allowable weld stresses were increased by 1/3.

SECTION 1.6 COMBINED STRESSES

- 1.6.1 Axial Compression and Bending. Formulas (1.6-1a), (1.6-1b), and (1.6-2) were revised to reflect bending about both axes.
- 1.6.3 Shear and Tension. Formulas were revised to reflect new fastener specifications and new units (kips, etc.).

SECTION 1.7 MEMBERS AND CONNECTIONS SUBJECT TO REPEATED VARIATION OF STRESS (FATIGUE)

Fatigue provisions were greatly expanded and moved from the main body of the specification to Appendix B.

SECTION 1.9 WIDTH-THICKNESS RATIOS

Constants changed to reflect F_y in ksi. Members with elements with b/t that exceed limits for fully effective elements are referenced to Appendix C for design stress reduction.

SECTION 1.10 PLATE GIRDERS AND ROLLED BEAMS .

Formula (1.10-6) for a reduced bending stress, F_b' , was added for hybrid members.

SECTION 1.11 COMPOSITE CONSTRUCTION

Major change was to allow for incomplete composite action based on a reduced transformed section modulus (Formula 1.11-1) and the addition of Formula (1.11-6) to check connector spacing, N_2 , in high concentrated load area.

SECTION 1.13 DEFLECTIONS, VIBRATION AND PONDING

- 1.13.2 Vibration. New paragraph. Detail provided in the *Commentary*.
- 1.13.3 Ponding. New paragraph giving formulas for minimum roof stiffnesses.

SECTION 1.17 WELDS

- 1.17.1 Revised to include operator qualifications for tackers
- 1.17.4 Electroslag and Electrogas Welding. New section.
- 1.17.5 Minimum size of Fillet Welds. Minimum weld size was reduced from 3/16 in. to 1/8 in. for material thicknesses to 1/4 in. Table 1.17.2 added showing welding process required for various base metals.

SECTION 1.23 FABRICATION

- 1.23.1 Straightening Material. Specifics added on method of straightening.
- 1.23.2 Oxygen Cutting. New section.
- 1.23.5 Riveted and High-Strength Bolted Construction – Assembling. Table 1.23.5 added showing minimum bolt tension for A325, A449, and A490 bolts. Also, washer requirements were revised.
- 1.23.6 Welded Construction. Revised section including a revision of Table 1.23.6 on Minimum Preheat and Interpass Temperature.

SECTION 1.26 QUALITY CONTROL

This section, previously titled "Inspection," was revised for clarity.

PART 2

SECTION 2.1 SCOPE

This section expanded to include design of braced multi-story rigid frames. Load factor revised to 1.70 for all conditions of gravity loading.

SECTION 2.2 STRUCTURAL STEEL

Plastic Design Limitation extended to steels of yield strength up to 65 ksi.

SECTION 2.3 VERTICAL BRACING SYSTEM

New section added.

SECTION 2.4 COLUMNS

All column formulas were revised to the more familiar form of Part 1.
A weak axis bending formula (2.4-4) was added.

SECTION 2.6 WEB CRIPPLING

Requirements modified to those in 1.15.5.

SECTION 2.7 MINIMUM THICKNESS (WIDTH-THICKNESS RATIOS)

Flange width-thickness ratio limits expressed in terms of F_y to provide for higher strength steels.
Web depth-thickness ratio limit redefined (Formulas 2.7-1a and 2.7-1b).

SECTION 2.9 LATERAL BRACING

Laterally unsupported distance was redefined (Formulas 2.9-1a and 2.9-1b) to reflect the significance of moment gradient.

APPENDIX A

Completely revised to facilitate using the increased number of steel strengths available.

APPENDIX B - FATIGUE

Section greatly expanded.

APPENDIX C - SLENDER COMPRESSION ELEMENTS

New section for designing members with elements not meeting the provisions of 1.9.

COMMENTARY

Completely rewritten to help explain the reasons for the revisions.

November 1, 1970 Adopted Supplement No. 1

This supplement revised the following sections in Part 1:

1.4.1.1	Deleted provisions for structural shapes and tubing of ASTM A514 strength level, and added standard ASTM A618 for HSLA tubing.
1.4.6 Shear Stud Connectors.	New section added to cover these materials.
1.5.1.3.1	Revised wording in reference to the column formula.
1.5.1.4.1	Revised subparagraph "d." related to depth-thickness ratio for webs of compact sections, replacing Formulas (1.5-4) with (1.5-4a) and (1.5-4b).
1.5.1.4.2	Changed Formula (1.5-5) to (1.5-5a) for allowable bending stress.
1.5.1.4.3	Added second paragraph and Formula (1.5-5b), a weak axis transition formula.
1.5.1.4.6a, 1.5.1.4.6b.	Reworded language related to bending strength formulas.
1.11.2.2	Reworded fourth paragraph on design assumptions for composite construction without temporary shoring.
1.15.5 Restrained Members (Connections).	Revised wording.
1.23.1 Cambering, Curving, and Straightening.	Changed title from "Straightening Material" and revised text.
1.23.6 Welded Construction.	Revised Table 1.23.6.

December 8, 1971 Adopted Supplement No. 2

This supplement revised the following sections in Part 1 and Appendix C:

- 1.4.1.1 Deleted ASTM A375 and added ASTM A606 and A607.
- 1.8.4 Maximum Ratios. Deleted "K" for tension members.
- 1.9.2.2 Stiffened Elements under Compression.
Revised wording.
- 1.10.2 Web. Reworded first paragraph.
- 1.10.5.3 Stiffeners. Revised first and third paragraphs.
- 1.10.8 Splices. Reworded first sentence.
- 1.11.2. Design Assumptions (Composite Construction).
In 1.11.2.2, revised second paragraph.
- 1.11.4 Shear Connectors. Revised third paragraph and added Table 1.11.4A. Fourth and final paragraphs also revised.
- 1.14.5 Size of Holes. Completely revised.
- 1.15.4 Unrestrained Members.
Second paragraph completely revised.
- 1.16.5 Minimum Edge Distance.
Revised Table 1.16.5 to include oversized and slotted holes.
- 1.18.2 Compression Members.
Reworded sixth sentence of 1.18.2.6.
- 1.23.5 Riveted and High-Strength Bolted Construction - Assembling.
Deleted fourth paragraph on cold driven rivets and revised fifth paragraph to permit certain coatings.
- 1.23.6. Welded Construction.
Revised eighth paragraph.

Appendix C:

SECTION C2.

Revised first sentence, sentence following Formula (C2-2), and Table C1.

SECTION C 3.

Revised definition of *f*.

June 12, 1974 Adopted Supplement No. 3

This supplement revised the following sections:

Part 1.

- 1.2 Types of Construction. Deleted "tier" from "tier buildings" in paragraph eight.
- 1.3.3 Impact. Redefined live load and added impact factor for pendant operated cranes (10%)
- 1.3.4 Crane Runway Horizontal Forces.
Modified load distribution at top of rails.
- 1.4.1.1 Deleted ASTM A440 and added reference to A568 in last paragraph.
- 1.4.4 Bolts. Deleted ASTM A449 bolts
- 1.4.6 Stud Shear Connectors.
Revised AWS reference.
- 1.5 Allowable Stresses. Added reference to Appendix D
- 1.5.1.4.1 Revised (b.) and (d.) on element slenderness criteria for compactness. Revised (e.) on lateral support and added (f.) for lateral support length limit for box sections.
- 1.5.1.4.2 Revised (1.5-5a) to agree with new flange width-thickness limits.
- 1.5.1.4.3 Revised (1.5-5b) to agree with new flange width-thickness limits.
- 1.5.1.4.4 Revised wording and included treatment of box sections with depth less than 6 times width.

1.5.1.4.6a	Revised footnote marked **, reworded definition of l (distance between brace points), revised criteria for determining C_b , and added footnote marked ***.
1.5.1.5.1	Revised first sentence
1.5.2.1	Deleted A449 from Table 1.5.2.1
1.5.3 Welds.	Revised format of Table 1.5.3, Allowable Stress.
1.5.5 Masonry Bearing.	Revised allowable bearing values on concrete
1.5.6 Wind and Seismic Stresses.	Reworded so as to include all except members and joints covered in Appendix B, Fatigue. Added footnote marked *.
1.6.3 Shear and Tension.	Deleted A449 bolts and added two paragraphs on 1/3 increase for wind or seismic.
1.10.6 Reduction in Flange Stress.	Revised definition of A_w .
1.10.10.2	Revised last two paragraphs on stress computation for web crippling.
1.11.2.2	Added sentence to first paragraph and revised second paragraph. Completely reworked paragraph containing Formula (1.11-2).
1.11.3 End Shear.	Changed "dead and live load" to "reaction."
1.11.4 Shear Connectors.	Added footnote to Formula (1.11-3) regarding reinforcing steel. Revised Table 1.11.4 and reworded paragraph above. Revised Table 1.11.4A and added Formula (1.11-7) with explanation. Last paragraph expanded.
1.11.5 Special Cases.	New section added.
1.14.7 Effective Areas of Weld Metal.	End of last paragraph revised
1.15.5 Restrained Members.	At end of first paragraph, deleted "when the member is fully loaded."
1.15.10 Rivets and Bolts in Combination with Welds.	Reworded last part of first paragraph.
1.16.1 High-Strength Bolts.	Deleted A449 bolts
1.17 Welds.	Revised references to AWS Code in 1.17.1 - 1.17.5. Added footnote to Table 1.17.5; revised footnotes to Table 1.17.2.
1.18.2.3	Revised next to last sentence to include welds.
1.23.4 Riveted and Bolted Construction – Holes.	Revised first sentence on oversized and slotted holes.
1.23.5 Riveted and High-Strength Bolted Construction – Assembling.	Deleted A449 in first and last sentence of last paragraph and in Table 1.23.5.
1.23.6 Welded Construction.	Revised AWS references in paragraph six and in last two paragraphs.
1.26.4 Inspection of Welding.	Revised AWS reference.
1.26.5 Identification of Steel.	Completely revised and new section title.

Part 2.

- 2.1 Scope. Revised first two paragraphs to include unbraced frames.
2.3 Vertical Bracing System. Retitled and revised to include 2.3.1 Stability of Braced Frames and 2.3.2 Stability of Unbraced Frames.

APPENDIX A. Tables for Section 1.5.1.4 Bending were revised for new flange slenderness, web slenderness, and box section unbraced lengths. Revised tables for Formula (1.5-5a) and (1.5-5b).

APPENDIX B – FATIGUE. Revised first paragraph of B2; deleted "C's" from Table B2.

APPENDIX D – TAPERED MEMBERS. New section added.

ADDENDA TO THE COMMENTARY. Sections revised were as follows:

- 1.5 Allowable Stresses
 - 1.5.1 Structural Steel
 - 1.5.1.3 Compression
 - 1.5.1.4 Bending
 - 1.8 Stability and Slenderness Ratios
- Appendix D Tapered Members

November 1, 1978 Revision

All provisions of Supplements 1, 2 and 3 were incorporated, and numerous sections were revised as listed below.

- 1.1.4 Standard Symbols and Nomenclature. Added Deep Longspan Steel Joists.
- 1.4.4 Bolts.
 - Added A449 in bearing-type connections with diameters over 1-1/2 in. and for anchor bolts or threaded rods
- 1.4.5 Filler Metal and Flux for Welding.
 - Changed format, added AWS A5.23 and deleted ref. to AWS Sect. 1.17.3
- 1.4.6 Stud Shear Connectors.
 - Changed reference to AWS D1.1-77.
- 1.5.1.1 Tension. Added reference to Sect. 1.14, revised wording and introduced term, "effective net area."
- 1.5.1.2 Shear. Divided into 1.5.1.2.1, previously covered in 1.5.1.2, and 1.5.1.2.2, block shear provisions.
- 1.5.1.4.1 Deleted "Tapered members" and revised format
- 1.5.1.4.3 Added paragraph after Formula (1.5-5b) on rectangular tubular sections.
- 1.5.1.4.5 Paragraph 1 was previously designated as 1.5.1.4.5. Paragraph 2 was previously designated as 1.5.1.4.6a. Paragraph 3 was previously designated as 1.5.1.4.6b.
- 1.5.2.1 First sentence reworded so area based on nominal diameter. Table 1.5.2.1 revised for higher allowable stresses, inclusion of provisions for oversized and slotted holes, and A449 added.
- 1.5.1.5.3 Previously listed as 1.5.2.2. Wording revised. Allowable bearing stress changed from $1.35F_y$ to $1.5F_y$.
- 1.5.2.2 New section for fatigue on bolts, referred to Appendix B3.
- 1.5.3 Welds. Table 1.5.3 clarifications and updated reference to AWS D1.1-77.
- 1.5.6 Wind and Seismic Stresses. Added "stress increase" to last sentence for clarity.

- 1.6.3 Shear and Tension. Revised wording and format.
Table 1.6.3 added for F_t based on higher allowable stresses, F_v also based on higher allowable stresses plus provisions for slotted and oversized holes.
- 1.8.1 General. In first paragraph, added a new sentence on significant load effects.
- 1.8.4 Maximum Ratios. Slenderness ratio for tension members changed from kl/r to l/r . Changed "Bracing" to "lateral bracing member" in last line.
- 1.9.2.3. New Section for circular tubular members
- 1.10.5.2 "Tapered members" deleted from last paragraph
- 1.10.5.4 In paragraph five, first two sentences (previously one sentence) rewritten.
- 1.11.2.2 In first sentence of second paragraph after "composite sections" wording, "subject to negative bending moment" was deleted.
In definition of S_{tr} below Formula (1.11-1), "based upon maximum permitted effective width of the concrete flange (Sect. 1.11.1) inches³" was added.
In the paragraph below Formula (1.11-2), "in the negative moment area" was added in the last sentence.
- 1.11.4 Shear Connectors. Formula designations (1.11-6) and (1.11-7) were reversed.
- 1.11.5 Composite Beams or Girders with Formed Steel Deck. New section added.
- 1.11.6 Special Cases. Previously designated as 1.11.5.
- 1.14 Gross and Net Areas. Previously titled, "Gross and Net Sections."
- 1.14.1 Definitions. Changed "section" to "area" twice; changed section references.
- 1.14.2 Net Area and Effective Net Area.
Previously 1.14.3, "Net Section"; Old 1.14.2, "Application," was deleted.
- 1.14.2.1 Previously 1.14.3. Changed "section" to "area" in two places. Reference to 85% of gross area was moved to 1.14.2.3.
- 1.14.2.2 New section introducing A_e and C_r .
- 1.14.2.3 Relocation of $0.85A_g$ limit; see 1.14.2.1 above
- 1.14.3 Angles. Previously designated as 1.14.4.
- 1.14.4 Size of Holes. Previously 1.14.5.
- 1.14.5 Pin Connected Members. Previously 1.14.6.
Net "section" changed to net "area" throughout.
Three paragraphs reworded.
- 1.14.6 Effective Area of Weld Metal.
Previously 1.14.7. Format changed to separate fillet and groove welds into different sub-sections (1.14.6.1 and 1.14.6.2). Reworded to agree with AWS D1.1-77, and Tables 1.14.6.1.2 and 1.14.6.1.3 added.
- 1.15.3 Placement of Rivets, Bolts, and Welds.
Added reference to members subject to fatigue loading.
- 1.15.5 Restrained Members.
Section completely revised so that formulas are based on actual force (times a load factor) whereas previously formulas were based on a "fully loaded" flange force.
- 1.15.7 Connection of Tension and Compression Members in Trusses.
Phrase beginning with "based upon the kind of stress. ..." was added to the end of the paragraph.
- 1.15.10 Rivets and Bolts in Combination with Welds.
Provision stating bolts in friction-type connection be installed prior to welding was deleted from first paragraph.
- 1.16.1 High-Strength Bolts.
Second paragraph on A449 bolts added.

- 1.16.4 Minimum Spacing. Previously "Minimum Pitch." Revised to permit oversized and slotted holes; Table 1.16.4.2 added.
- 1.16.5 Minimum Edge Distance.
Section changed to permit oversized and slotted holes.
Table 1.16.5.2 added; Table 1.16.5.1 was previously designated as 1.16.5.
Formula (1.16-3) added to cover case where a reaction might tend to tear thru end of beam web.
- 1.16.6 Maximum Edge Distance.
Previously designated as 1.16.7.
- 1.17.1 Length of Fillet Welds.
Previously Sections 1.17.1 thru 1.17.4; old Table 1.17.2 deleted.
- 1.17.2 Minimum Size of Fillet Welds and Partial-Penetration Welds.
Previously designated as 1.17.5.
Revised Table 1.17.2A (previous designated 1.17.5), upper limit of "over 3/4" was previously "over 6."
Partial penetration groove welds and new Table 1.17.2B added.
- 1.17.3 Maximum Size of Fillet Welds.
Previously designated as 1.17.6. First sentence deleted and "fillet welds" inserted in second (now first) sentence.
- 1.17.4 through 1.17.9 renumbered. Previously 1.17.8 through 1.17.12.
- 1.23.4 Riveted and Bolted Construction - Holes.
Extensively revised to include oversized and slotted holes.
Table 1.23.4 added.
- 1.23.5 Riveted and High-Strength-Bolted Construction – Assembling.
Surfaces listed as (1), (2) and (3) after the fourth paragraph were replaced with a reference to Appendix E.
- 1.23.6 Welded Construction.
Thirteen paragraphs and Table 1.23.6 were deleted and replaced with reference to AWS D1.1-77, Section 3 and 4.
- 1.23.7 Compression Joints.
Reworded; previously titled "Finishing."
- 1.23.8 Dimensional Tolerances.
Five paragraphs replaced with reference to Section 6.4 of *AISC Code of Standard Practice*.
- 1.24.2 Inaccessible Surfaces.
Reworded for clarity.
- 1.24.3 Contact Surfaces. Added exception for Appendix E special surfaces and expanded.
- 1.24.4 Finished Surfaces. Changed "easily removed" to "removed" in second line.
- 1.24.5 Surfaces Adjacent to Field Welds.
Changed "objectional fumes" to "toxic fumes" in second line.
- 1.25.1 Bracing. Reference to *Code of Standard Practice* revised.
- 1.25.4 Fit of Column Compression Joints. New section.
- 1.25.5 and 1.25.6 renumbered. Previously 1.25.4 and 1.25.5.

APPENDIX A

This Appendix was extensively revised. Total number of pages reduced by concentrating on two steel yield points, 36 and 50 ksi, and by changing the format.

APPENDIX B - FATIGUE

BI – LOADING CONDITIONS Table B2 was revised to agree with latest AASHTO fatigue provisions and Figure B1 revised accordingly.

B3 – PROVISIONS FOR MECHANICAL FASTENERS

New section added.

APPENDIX C – SLENDER COMPRESSION ELEMENTS

Title changed and final paragraph added for circular tubular members.

APPENDIX D – WEB-TAPERED MEMBERS

Editorial changes throughout.

D4 – COMBINED STRESSES Last sentence regarding $(Kl/r) \geq Cc$ added.

APPENDIX E – ALLOWABLE SHEAR STRESSES IN FRICTION-TYPE CONNECTIONS

New section recognizing nine classes of commercially practical surface conditions (Classes A through I).

COMMENTARY

Revised to document and explain *Specification* changes.

March 11, 1986 Supplement No. 1

- 1.15.12 Field Connections. Following the list of connections where fully-tensioned high-strength bolts or welds must be used, the section was revised to: “In all other cases, connections may be made with high-strength bolts tightened to the snug-tight condition or with A307 bolts.”
- 1.23.5 Riveted and High-Strength Bolted Construction- Assembling. Added provisions for snug-tight bolting.
- 1.26.6 Inspection of Bolting. New section dealing with inspection of snug-tight bolting.

January 1, 1989 Supplement No. 2

- 1.4.1.3 New section giving testing requirements (toughness) for ASTM A6 Group 4 and 5 shapes spliced with welds and welded plates exceeding 2-in. thickness subject to primary tensile stresses due to tension or flexure.
- 1.15.13 Splices in Heavy Sections. New section giving weld requirements for Group 4 and 5 shapes and plates exceeding 2-in. thickness subject to primary tensile stresses due to tension or flexure.
- 1.15.14 Beam Copes and Weld Access Holes New section giving specifications for making beam copes and weld access holes.
- 1.17.10 Mixed Weld Metal. New section.
- 1.17.11 Preheat for Heavy Shapes. New section specifying preheat of at least 350°F when groove welding splices of Group 4 and 5 shapes or plates more than 2-in. thick.
- 1.23.2 Thermal Cutting. Reworded with revisions.

June 1989 Revision

In this edition, the material was completely reorganized with new chapter and section designations to parallel those in Chapters A through M of the 1986 LRFD *Specification*. In the 1989 AISC *Manual*, 9th Ed., a table on pages 5-2 through 5-9 cross references the new sections to the old ones. The revisions made in Supplements 1 and 2 to the previous edition were included in the new *Specification*, except for Section 1.26.6, which was deleted. The following listing only includes sections where the content was substantially reworded or changed technically. Designations for the old sections they replace are indicated in parentheses.

CHAPTER A - GENERAL PROVISIONS

- | | | |
|-------|--|---|
| A1 | SCOPE | |
| A2 | LIMITS OF APPLICABILITY | |
| A2.1 | Structural Steel Defined. | New section. |
| A3 | MATERIAL | |
| A3.1 | Structural Steel | |
| A3.1a | ASTM designations (1.4.1.1) | Updated approved ASTM specifications for structural steel.
A709 and A852 added. |
| A3.4 | Bolts, Washers and Nuts (1.4.4) | Added Carbon and Alloy Steel Nuts, A563, and Hardened Steel Washers, F436. |
| A3.5 | Anchor Bolts and Threaded Rods | New section giving approved ASTM specifications for these items. |
| A4 | LOADS AND FORCES | |
| A4.3 | Crane Runway Horizontal Forces (1.3.4) | Revised wording in second paragraph.
Added sentence at end of section requiring design for crane stop forces. |
| A5 | DESIGN BASIS | |
| A5.1 | Allowable Stresses (1.5) | Reworded with no technical revisions |
| A5.3 | Structural Analysis | New section discussing loading and selection of analysis methods. |
| A5.4 | Design for Serviceability and Other Considerations | New section referring to Chapter L for design for serviceability. |
| A6 | REFERENCED CODES AND STANDARDS | New section specifying adoption dates of specific codes and standards referenced. |
| A7 | DESIGN DOCUMENTS | |
| A7.1 | Plans (1.1.1) | Changed “plans” to “design documents.”
Added that stiffener and bracing requirements must be included in the design documents. |
| A7.2 | Standard Symbols and Nomenclature (1.1.4) | Deleted reference to steel joists (last paragraph). |
| A7.3 | Notation for Welding (1.1.3) | Reworded slightly. |

CHAPTER B - DESIGN REQUIREMENTS

- B3 EFFECTIVE NET AREA (1.14.2.2, 1.14.2.3)
Completely revised with new reduction coefficient, U , and accompanying rules.
- B5 LOCAL BUCKLING
B5.1 Classification (1.9.1, 1.9.2, 1.5.1.4.1)
Tabulation of limiting width-thickness ratios for all types of compression elements. Inclusion of a new factor, k_c , in the limiting width-thickness ratio for noncompact flanges of I-shaped welded beams in flexure, and angles or plates projecting from girders, built-up columns or other compression members, including compression flanges of plate girders.
- B7 LIMITING SLENDERNESS RATIOS (1.8.4)
For compression members, “shall not” was replaced by “should not.” Added reminder that the allowable compressive strength cannot be exceeded.
For tension members, reference to secondary members deleted and maximum slenderness ratio, L/r , for main members given as 300. Rods are excluded.
- B10 PROPORTIONS OF BEAMS AND GIRDERS (1.10.1, 1.10.3, 1.10.4)
Old Section 1.10.1 revised extensively. The old rule whereby no deduction was made in section properties unless flange holes exceeded 15 percent of gross flange area, was replaced by new relationships involving the gross and net flange area and the yield and tensile strength of the material.
Deleted footnote to old Section 1.10.4 regarding cover plate termination.

CHAPTER C - FRAMES AND OTHER STRUCTURES

- C1 GENERAL
New section reminding the designer that deformation capacity and overall frame stability should be considered in addition to member strength and stiffness.

CHAPTER D - TENSION MEMBERS

- D1 ALLOWABLE STRESS (1.5.1.1)
Section 1.5.1.1 was divided between D1 and D3.1.
Added reminder that block shear strength shall be checked at end connections of tension members in accordance with J4.
Also added, “Eyebars shall meet the requirements of D3.1.”
Reference to threaded parts in tension is in the introduction to Chapter D.

- D2 BUILT-UP MEMBERS (1.18.3)
 Added connector spacing requirements for unpainted weathering steel subject to atmospheric corrosion: “The longitudinal spacing of connectors between elements in continuous contact consisting of a plate and a shape or two plates shall not exceed: 14 times the thickness of the thinner plate, nor 7 in. for unpainted members of weathering steel subject to atmospheric corrosion.”
 Increased the limiting slenderness ratio of either component between fasteners in built-up tension members separated by intermittent fillers from 240 to 300.
- D3 PIN-CONNECTED MEMBERS
- D3.1 Allowable Stress (1.5.1.1)
 Added reminder that the bearing stress on the projected area of the pin shall not exceed the stress allowed in Section J3 (Allowable Bearing Stress).
 Added allowable stress requirements for eyebars; $0.60F_y$ on the body area.
- D3.2 Pin-Connected Plates (portions of 1.14.5)
 Reworded and some clarification, e.g., “The distance used in calculations, transverse to the axis” and “For calculation purposes, the distance from the edge of the pin hole to the edge of the plate”
- D3.3 Eyebars (portions of 1.14.5)
 Reworded with the following new provision: “For calculation purposes, the distance from the hole edge to plate edge perpendicular to the direction of the applied load shall not be less than $2/3$ nor greater than $3/4$ times the width of the eyebar body.”
 Also revised the provision for steels with greater than 70 ksi yield stress, “...the hole diameter shall not exceed 5 times the plate thickness and the width of the eyebar shall be reduced accordingly.”
- CHAPTER E - COLUMNS AND OTHER COMPRESSION MEMBERS
- E1 EFFECTIVE LENGTH AND SLENDERNESS RATIO (portion of 1.8.1)
 Added reference to Section C2 for effective length factor, K.
- E2 ALLOWABLE STRESS
 Equation for allowable stress for bracing when $l/r > 120$ was eliminated.
- E3 FLEXURAL-TORSIONAL BUCKLING
 New section.
- E4 BUILT-UP MEMBERS (1.18.2)
 Add second paragraph referring to Section J3.10 for spacing and edge distance requirements for weathering steel members. Some rewording and clarification, e.g., in 4th paragraph, 3rd sentence, “In addition, for painted members and unpainted members not subject to corrosion where the outside component consists of a plate,”
 Revised provisions for spacing of intermittent fillers so the slenderness ratio, Kl/r , of either shape, between fasteners, does not exceed $3/4$ times the governing slenderness ratio of the

built-up member. Also limits the minimum number of intermediate connectors to two.
New provision states that, "All connections, including those at the ends, shall be welded or shall utilize high-strength bolts tightened to the requirements of Table J3.7." (fully-tightened)
Eliminated reference to secondary members.

E5 PIN-CONNECTED COMPRESSION MEMBERS

New section requiring these members to conform to Section D3 requirements.

CHAPTER F - BEAMS AND OTHER FLEXURAL MEMBERS

F1 ALLOWABLE STRESS: STRONG AXIS BENDING OF I-SHAPED MEMBERS AND CHANNELS

- F1.1 Members with Compact Sections (1.5.1.4.1)
Reworded. Also, upper limit for $F_b = 0.66F_y$ changed from 100 to 65 ksi.
- F1.2 Members with Noncompact Sections (1.5.1.4.2, 1.5.1.4.5(2b))
Added equation for allowable bending stress for braced built-up members with noncompact flanges.
Upper limit for F_b per Equation (1.5-5a) changed from 100 to 65 ksi.
- F1.3 Members with Compact or Noncompact Sections with Unbraced Length Greater than L_c (1.5.1.4.5(1 and 2a))
Reworded and added last sentence, "Section F1.3 does not apply to tee sections if the stem is in compression anywhere along the unbraced length. "

F2 ALLOWABLE STRESS: WEAK AXIS BENDING OF I-SHAPED MEMBERS, SOLID BARS AND RECTANGULAR PLATES

- F2.1 Members With Compact Sections (portion of 1.5.1.4.3)
Reworded with no technical revisions.
- F2.2 Members With Noncompact Sections (1.5.1.4.3, 1.5.1.4.5(2b))
Reworded with no technical revisions

F3 ALLOWABLE STRESS: BENDING OF BOX MEMBERS, RECTANGULAR TUBES AND CIRCULAR TUBES

- F3.1 Members With Compact Sections (portions of 1.5.1.4.1/3))
Reworded with no technical revisions.
- F3.2 Members With Noncompact Sections (1.5.1.4.4)
Reworded with no technical revisions.

F4 ALLOWABLE SHEAR STRESS (1.5.1.2.1, portions of 1.10.5.2)

Combined allowable shear stress provisions for rolled and built-up shapes into one section.
Added reminder to check block shear on coped beam ends.
Refers to Chapter G for maximum h/t_w limits.
Refers to Chapter G for tension field action design method for plate girders.

F5 TRANSVERSE STIFFENERS (portions of 1.10.5.3)

Reworded with no technical revisions.

CHAPTER G - PLATE GIRDERS

G2 ALLOWABLE BENDING STRESS (1.10.6)

The plate girder factor (old Equation (1.10-5)), now called R_{PG} , and the hybrid girder factor (old Equation (1.10-6)), R_e , were multiplied together in equation for maximum allowable bending stress in the compression flange (Equation (G2-1)). The definition of α was changed from F_{yw}/F_b to $0.6 F_{yw}/F_b \leq 1.0$.

G5 COMBINED SHEAR AND TENSION STRESS (1.10.7)

Slightly reworded.
Revised reference to A514 steel to 65 ksi.

CHAPTER H - COMBINED STRESSES

H1 AXIAL COMPRESSION AND BENDING (1.6.1)

Under the definition of C_m , for the third case, revised statements as follows:

“a. For members whose ends are restrained against rotation in the plane of bending . . .”

“b. For members whose ends are unrestrained against rotation in the plane of bending. . .”

H2 AXIAL TENSION AND BENDING (1.6.2)

Replaced text with Equation (H2-1); $0.60F_y$ was replaced with F_t in new equation.

Reworded last sentence to read:

“However the computed bending compressive stress arising from an independent load source relative to the axial tension, taken above, shall not exceed the applicable value required in Chapter F.”

CHAPTER I - COMPOSITE CONSTRUCTION

I1 DEFINITION (1.11.1)

Reworded and revised effective slab width definition as follows:

“The portion of the effective width of the concrete slab on each side of the beam centerline shall not exceed:

- a. One-eighth of the beam span, center-to-center of supports;
 - b. One-half the distance to the centerline of the adjacent beam;
- or
- c. The distance from the beam centerline to the edge of the slab.”

I2 DESIGN ASSUMPTIONS (1.11.2)

Old Equation (1.11-2) was replaced by the following: “For composite beams constructed without temporary shoring, stresses in the steel section shall not exceed $0.90F_y$.”

Also rewording.

I5 COMPOSITE BEAMS OR GIRDERS WITH FORMED STEEL DECK(1.11.5.2)

15.2 Deck Ribs Oriented Perpendicular to Steel Beam or Girder

The spacing of stud shear connectors along the length of a supporting beam or girder was increased to 36 in.

CHAPTER J - CONNECTIONS, JOINTS AND FASTENERS

- J1 GENERAL PROVISIONS
- J1.1 Design Basis
New section.
- J1.2 Simple Connections (1.15.4)
Reworded with no technical revisions.
- J1.3 Moment Connections (1.15.5.1)
Reworded with no technical revisions.
- J1.4 Compression Members with Bearing Joints (1.15.8)
Reworded with no technical revisions.
- J1.5 Connections of Tension and Compression Members in Trusses (1.15.7)
Revised to read:
“The connections at ends of tension or compression members in trusses shall develop the force due to the design load, but not less than 50% of the effective strength of the member, unless a smaller percentage is justified by engineering analysis that considers other factors including handling, shipping and erection.”
- J1.9 Placement of Welds, Bolts and Rivets (1.15.3)
Reworded with no technical revision.
- J1.10 Bolts in Combination with Welds (1.15.10)
The last paragraph pertaining to making welded alterations to structures was revised to read as follows:
“... existing rivets and high-strength bolts tightened to the requirements for slip- critical connections are permitted for carrying stresses resulting from loads present at the time of alteration, and the welding need be adequate to carry only the additional stress. “
- J1.11 High-Strength Bolts in Slip-Critical Connections in Combination with Rivets (1.15.11)
Revised wording.
- J2 WELDS (1.17.1)
Added Section 10 to the list of provisions of the AWS D1.1 which do not apply to work performed under this *Specification*.
- J2.1 Groove
- J2.1a Effective Area (1.14.6.1)
Revised first sentence of old Section 1.14.6.1.3 to read:
“The effective throat thickness of a flare groove weld when flush to the surface of a bar or 90° in a formed section shall be as shown in Table J2.2.”
- J2.1b Limitations (portions of 1.17.2)
Deleted last part of second sentence in old Section 1.17.2,
“...unless a larger size is required by calculated stress.”
- J2.2 Fillet Welds
- J2.2b Limitations (portions of 1.17.2 through 1.17.8)
Part was reworded for clarification
Added the following, pertaining to side or end fillet welds:
“For framing angles and simple end-plate connections which depend upon flexibility of the outstanding legs for connection flexibility, end returns shall not exceed four times the nominal size of the welds. Fillet welds which occur on opposite sides of a common plane shall be interrupted at the corner common to both welds.”
- J2.3 Plug and Slot Welds

J2.3b Limitations (1.17.9)
The provisions for hole diameter for a plug weld were revised to read as follows:
“... shall not be less than the thickness of the part containing it plus 5/16-in., rounded to the next larger odd 1/16-in., nor greater than the minimum diameter plus 1/8-in. or 2 1/4 times the thickness of the weld.”

J3 BOLTS, THREADED PARTS AND RIVETS

- J3.1 High-Strength Bolts (1.16.1)
Revised second paragraph of Section 1.16.1 as follows:
“If required to be tightened to more than 50% of their minimum specified tensile strength, ASTM A449 bolts in tension and bearing-type shear connections shall have an ASTM F436 hardened washer installed under the bolt head, and the nuts shall meet the requirements of ASTM A563.”
- J3.2 Size and Use of Holes (1.23.4.1 and portions of 1.23.4.2 through 1.23.4.5)
Added the following to discussion on standard holes:
“Finger shims up to 1/4 in. may be introduced into slip-critical connections designed on the basis of standard holes without reducing the allowable shear stress of the fastener.”
Added the following: “When A490 bolts over 1-in. dia. are used in slotted or oversize holes in external plies, a single hardened washer conforming to ASTM F436, except with 5/16-in. minimum thickness, shall be used in lieu of the standard washer.”
Remainder of section reworded and reference to rivets deleted.
- J3.3 Effective Bearing Area (1.16.2)
This section now includes threaded parts.
- J3.4 Allowable Tension and Shear (1.5.2.1 and 1.5.2.2)
Added the following two paragraphs:
“When specified by the designer, the nominal slip resistance for connections having special faying surface conditions may be increased to the applicable values in the *RCSC Specification for Structural Joints Using ASTM A325 or A490 Bolts.*”
“Finger shims up to 1/4-in. may be introduced into slip-critical connections designed on the basis of standard holes without reducing the allowable shear stress of the fastener to that specified for slotted holes.”
Revised allowable shear values for slip-critical connections given in the table of Allowable Stress on Fasteners (Table J3.2).
- J3.7 Allowable Bearing at Bolt Holes (1.5.1.5.3)
This section was completely revised.
- J3.8 Minimum Spacing (1.16.4)
Equation (J3-5) (old Equation 1.16-1) intended for bolt spacings less than 3d.
- J3.9 Minimum Edge Distance (1.16.5.1, 1.16.5.2, 1.16.5.4)
Equation (J3-6) (old Equation 1.16-2) intended for edge distances less than 1.5d.
Deleted Section 1.16.5.3 (end distance).
- J3.10 Maximum Edge Distance and Spacing (1.16.6)
Added provisions for unpainted steel made of weathering steel.

- J4 ALLOWABLE SHEAR RUPTURE (1.5.1.2.2)
Reworded and Equation (J4-2) added for tension acting along a perpendicular plane at beam end connections.
- J5 CONNECTING ELEMENT S
J5.2 Allowable Shear Rupture
New section referring back to Section J4.
- J9 COLUMN BASES AND BEARING ON MASONRY AND CONCRETE (1.5.5,1.21.1)
Revised definitions for A_1 and A_2 .
- J10 ANCHOR BOLTS (1.22)
Reworded.

CHAPTER K - SPECIAL DESIGN CONSIDERATIONS

K1 WEBS AND FLANGES UNDER CONCENTRATED FORCES

- K1.1 Design Basis (new)
New section outlining Chapter K and the application of its sections.
- K1.2 Local Flange Bending (portion of 1.15.5.3)
Equation (K1-1) (old Equation 1.15-3) is also applicable when a flange plate of a beam or girder frames into the member under consideration.
Following new provision added:
“If the length of loading measured across the member flange is less than $0.15b$, where b is the member flange width, Equation (K1-1) need not be checked.”
- K1.3 Local Web Yielding (1.10.10.1)
Changed unstiffened compressive stress at web toe of beam fillets resulting from concentrated loads to $0.66F_y$, and made corresponding revisions to equations.
- K1.4 Web Crippling (1.10.10.2)
Completely revised section.
- K1.5 Sidesway Web Buckling (new)
New section giving bearing stiffener provisions in webs of members with flanges not restrained against relative movement by stiffeners or lateral bracing and subject to concentrated compressive loads.
- K1.7 Compression Members with Web Panels Subject to High Shear
New section referring back to Section F4 for these types of members.
- K1.8 Stiffener Requirements for Concentrated Loads (1.10.5.1, 1.15.5.4, 1.15.5.2)
Reworded; Deleted Item 3 of Section 1.15.5.4.

- K2 PONDING (1.13.3)
Reworded.

- K3 TORSION
New section stating that torsion shall be considered.

CHAPTER L - SERVICEABILITY DESIGN CONSIDERATIONS

- L1 CAMBER (1.19)
Some rewording; in first paragraph, after “with the work of other trades”, deleted “as for the attachment of runs of sash.”

L3	DEFLECTION, VIBRATION AND DRIFT	
L3.2	Vibration (1.13.2)	After “sources of damping,” deleted “where transient vibration due to pedestrian traffic might not be acceptable.”
L4	CONNECTION SLIP	New section referring to Section J3.
L5	CORROSION	New section.
CHAPTER M - FABRICATION, ERECTION AND QUALITY CONTROL		
M1	SHOP DRAWINGS (1.1.2)	Added that shop drawings “shall clearly identify type of high-strength bolted connection (snug-tight or fully-tightened bearing, or slip-critical).”
M2	FABRICATION	
M2.1	Cambering, Curving and Straightening (1.23.1)	Modified and added as follows: “The temperature of heated areas, as measured by approved methods, shall not exceed 1050°F for A852 steel, 1100°F for A514 steel nor 1200°F for other steels. <u>The same limits apply for equivalent grades of A709 steels.</u> ”
M2.3	Planing of Edges (1.23.3)	Reworded without technical revisions.
M2.5	High-Strength Bolted Construction-Assembly (portions of 1.23.4.2 and 1.23.5)	Deleted “Holes that must be enlarged to admit the rivets or bolts shall be reamed.” Deleted two paragraphs on rivets. Added the following: “The orientations of fully inserted finger shims, with a total thickness of not more than 1/4-in. within a joint, is independent of the direction of application of the load.” “Burrs that would prevent solid seating of the connected parts in the snug-tight condition shall be removed.” “The use of high-strength bolts shall conform to the requirements of the RCSC <i>Specification for Structural Joints Using ASTM A325 or A490 Bolts.</i> “
M2.6	Compression Joints (1.23.7)	Deleted “to a common plane” in reference to “bearing surfaces of individual fabricated pieces prepared by milling, sawing or other suitable means”.
M2.8	Finishing of Column Bases (1.23.8)	Added: “The top surfaces of base plates with columns full-penetration welded need not be pressed or milled.”
M3	SHOP PAINTING	
M3.2	Inaccessible Surfaces (1.24.2)	“Design documents” replaced “job specifications”.
M3.3	Contact Surfaces (1.24.3)	Updated with new provisions for slip-critical connections.
M4	ERECTION	
M4.1	Alignment of Column Bases (1.21.2)	

		Provision for full bearing also now includes concrete, in addition to masonry.
M4.4	Fit of Column Compression Joints (1.25.4)	Groove-welded added in reference to “type of splice used” (replaced riveted).
M4.5	Field Welding (1.25.5)	Reworded.
M4.6	Field Painting (1.25.6)	In the text, “field-painting” replaced “general painting”, and “design documents” replaced “contract”.
M5	QUALITY CONTROL	
		“Design documents” replaced “information furnished to the bidders” throughout.
M5.3	Inspection of Welding (1.26.4)	Deleted “technique” in reference to acceptance of required nondestructive testing.
M5.4	Inspection of Slip-critical, High-Strength Bolted Connections	New section referring to the RCSC <i>Allowable Stress Design Specification for Structural Joints Using ASTM A325 or A490 Bolts</i> .
CHAPTER N - PLASTIC DESIGN		
		Minor editorial changes.
APPENDIX B - DESIGN REQUIREMENTS (Appendix C)		
B5	LOCAL BUCKLING	
B5.2a	Unstiffened Compression Elements	Equations for angles or plates projecting from columns or other compression members, and for projecting elements of compression flanges of beams and girders, were revised to include the k_c factor.
B5.2b	Stiffened Compression Elements	Reworded.
B5.2c	Design Properties	Reworded.
B5.2d	Combined Axial and Flexural Stress	Added the following: “The term $f_a/0.60F_y$ in Equations (HI-2) and (A- F7-13) shall be replaced by $f_a/0.60F_yQ$.”
APPENDIX F - BEAMS AND OTHER FLEXURAL MEMBERS (Appendix D)		
F7	WEB-TAPERED MEMBERS	
F7.1	General Requirements	Small l replaced by L and definition revised.
F7.2	Allowable Tensile Stress	New section referring to Section D1.
F7.4	Allowable Flexural Stress	Small l replaced by L in equations.
F7.5	Allowable Shear	New section referring to Section F4.

APPENDIX K - STRENGTH DESIGN CONSIDERATIONS (portion of 1.7.1 and Appendix B)

K4 FATIGUE

- K4.1 Loading Conditions; Type and Location of Material
Table A-K4.2 revised to include two new stress categories, B' and E'.
- K4.2 Allowable Stress Range
Table A-K4.3 revised to include two new stress categories, B' and E'.
- K4.3 Tensile Fatigue
New requirements given for A325 or A490 bolts subject to tensile fatigue loading due to combined applied load and prying forces: "... prying force shall not exceed 60% of the externally applied load."

NUMERICAL VALUES (Appendix A)

This section contains the tables previously in Appendix A.

September 1, 1986 Load and Resistance Factor Design Specification for Structural Steel Buildings

This was the first edition of a completely new specification in LRFD format. As indicated in the Commentary, "It involves explicit consideration of limit states, multiple load factors, and resistance factors, and implicit probabilistic determination of reliability."

January 1, 1989 Supplement No. 1 to LRFD Specification

This *Supplement* was issued in response to problems encountered with the use of heavy W-shapes in non-column applications. The new provisions covered material properties, splicing details, thermal cutting and welding of such shapes.

- A3.1a New section giving testing requirements (toughness) for ASTM A6 Group 4 and 5 shapes spliced with welds and welded plates exceeding 2-in. thickness subject to primary tensile stresses due to tension or flexure.
- J1.10 Splices in Heavy Sections
New section giving weld requirements for Group 4 and 5 shapes and plates exceeding 2-in. thickness subject to primary tensile stresses due to tension or flexure.
- J1.11 Beam Copes and Weld Access Holes
New section giving specifications for making beam copes and weld access holes.
- J2.7 Mixed Weld Metal.
New section regarding notch-tough weld metal.
- J2.8 Preheat for Heavy Shapes.
New section specifying preheat of at least 350°F when groove welding splices of Group 4 and 5 shapes or plates more than 2-in. thick.
- 1.23.2 Thermal Cutting.
Reworded with revisions.

December 1, 1993 Load and Resistance Factor Design Specification for Structural Steel Buildings

The contents of *Supplement No. 1* were included in the revised *Specification* and revisions were made as indicated below.

A2 LIMITS OF APPLICABILITY

- A2.2 Types of Construction.
Deleted reference to Section B4 for stability requirements.
Added that type of construction assumed in design be indicated on design documents.
Added documentation requirement for PR connections.

- A3 MATERIAL
- A3.1 Structural Steel
Divided into subparagraphs a, b, and c.
Deleted A441 and added A709 and A852 steels.
- A3.1c Heavy Shapes
Extended supplementary requirements for thick material to include certain welded joints.
- A3.3 Bolts, Washers, and Nuts
Added A194 nuts.
- A3.4 Anchor Bolts and Threaded Rods
Added A193 bolts and A572 steel.
Added that A449 material is acceptable for anchor bolts and threaded rods of any diameter.
- A4 LOADS AND LOAD COMBINATIONS
Made reference to ASCE 7 for loads in the absence of a code.
Made reference to the AISC Seismic Provisions for Structural Steel Buildings for the design of buildings in higher risk categories.
Load combinations listed per ASCE7 included some changes.
- A5 DESIGN BASIS
- A5.1 Required Strength at Factored Loads
The 1/10th reduction in negative moment was restricted to cases where the axial force did not exceed $0.15A_gF_y$.
- A6 REFERENCED CODES AND STANDARDS
General update with references added to *AISI Load and Resistance Factor Design Specification for Cold-Formed Steel Members*, *AISC Code of Standard Practice for Steel Buildings and Bridges*, *AISC Seismic Provisions for Structural Steel Buildings*, and *AISC Specification for Load and Resistance Factor Design of Single-Angle Members*.
- CHAPTER B – DESIGN REQUIREMENTS
- B1 GROSS AREA
Material regarding when deduction of area of holes in flexural members is required, rewritten and moved to B10.
- B2 NET AREA
Sentence deleted defining “critical net area.”
- B.3 EFFECTIVE NET AREA
This section was rewritten with many changes in the definition of the reduction coefficient U .
The equation $U = 1 - (x/L) \leq 0.9$ was introduced.
- B5 LOCAL BUCKLING
- B5.1 Classification of Steel Sections
In Table 5.1, Limiting Width-Thickness Ratios for Compression Elements, the factor, k_c , was introduced in certain definitions and other changes were made.
- B7 LIMITING SLENDERNESS RATIOS
Requirements changed for tension members subjected to “some compression.”
- B8 SIMPLE SPANS
New section defining span length for simple spans.
- B9 END RESTRAINT
New section permitting some inelastic deformation in restrained connections.

B10 PROPORTIONS OF BEAMS AND GIRDERS

The old rule (old B1) whereby no deduction was made in section properties unless flange holes exceeded 15 percent of gross flange area, was replaced by new relationships involving the gross and net flange area and the yield and tensile strength of the material.

Extensive rules for cover plates added.

CHAPTER C – FRAMES AND OTHER STRUCTURES

C1 SECOND ORDER EFFECTS

This section was changed from a one-sentence requirement that “second order effects shall be considered in the design of frames,” to a detailed set of requirements for determining second order effects of structures designed either on the basis of plastic analysis or elastic analysis. An equation was included that could be used to determine the required flexural strength from the results of a first-order elastic analysis using B_1 and B_2 factors. This material was previously covered in H1.2.

C2 FRAME STABILITY

C2.1 Braced Frames

Limitation added on axial force in structures designed on the basis of plastic analysis.

C2.2 Unbraced Frames

Requirement that K shall not be less than unity deleted, and consideration of certain destabilizing effects added.

CHAPTER D – TENSION MEMBERS

References added to other sections of the *Specification*.

D2 BUILT-UP MEMBERS

Limitations on spacing of connectors between elements moved to J3.5.

D3 PIN-CONNECTED MEMBERS AND EYEBARS

This section was rewritten.

The equation for nominal shear strength was expressed in terms of the tensile strength.

The equation for bearing strength was deleted and reference made to Section J8 instead.

CHAPTER E – COLUMNS AND OTHER COMPRESSION MEMBERS

References added to other sections of the *Specification* and to the *AISC Specification for Load and Resistance Factor Design of Single-Angle Members*.

E3 DESIGN COMPRESSIVE STRENGTH FOR FLEXURAL-TORSIONAL BUCKLING

Equations added for double-angle and box-shaped members with slender elements.

E4 BUILT-UP MEMBERS

Limitations on spacing of connectors between elements of weathering steel moved to J3.5.

Limitations on edge distance for such connectors deleted.

Revised provisions for spacing of intermittent fillers so the slenderness ratio, Kl/r , of either shape, between fasteners, does not exceed 3/4 times the governing slenderness ratio of the built-up member. Also limits the minimum number of intermediate connectors to two.

End connections must be welded or utilize high-strength bolts, fully-tensioned and with specified surfaces.

Equation for modified member Kl/r provided to replace previous two.

CHAPTER F – BEAMS AND OTHER FLEXURAL MEMBERS

Introductory inclusion statements modified, including references to other sections of the *Specification* and to the *AISC Specification for Load and Resistance Factor Design of Single-Angle Members*.

F1 DESIGN FOR FLEXURE

The first two paragraphs were deleted and subsections were renumbered and renamed.

F1.1 Yielding

New section with equations given for limit state of yielding.

- F1.2 Lateral-Torsional Buckling
 Rewritten from old F1.2 and 1.3 with clarifications; divided into 2a through 2d.
 Equation for C_b factor changed.
 C_b deleted from equation for critical moment of tees and double angles.
 Added equations for unbraced length for design by plastic analysis in section F1.2d.
- F2 DESIGN FOR SHEAR
 Introductory inclusion statements modified, including references to other sections of the *Specification*.
- F2.2 Design Shear Strength
 Revised shear strength equations, eliminating the coefficient k .
- F2.3 Transverse Stiffeners
 Old F3 deleted and stiffener design referred to Appendix F2.3.
- F4 BEAMS AND GIRDERS WITH WEB OPENINGS
 New section requiring effect of web openings on strength be considered and reinforcement added when necessary.
- CHAPTER G – PLATE GIRDERS
 This brief five-sentence chapter, which refers to the Appendix for design provisions, was modified to more clearly distinguish between various types of girders.
- CHAPTER H – MEMBERS UNDER COMBINED FORCES AND TORSION
- H1 SYMMETRIC MEMBERS SUBJECTED TO BENDING AND AXIAL FORCE
 H1.2 Doubly and Singly Symmetric Members in flexure and Compression
 Much of the material previously in this section was moved to C1.
- CHAPTER I – COMPOSITE BEAMS
- I5 SHEAR CONNECTORS
 I5.2 Horizontal Shear Force
 Added sentence on calculation of yield force for hybrid beams.
- CHAPTER J – CONNECTIONS, JOINTS, AND FASTENERS
- J1 GENERAL PROVISIONS
 Subsections rearranged and renumbered.
- J2 WELDS
 Listed specific exemptions from certain AWS D1.1 provisions.
- J2.2 Fillet Welds
 J2.2a Effective Area
 Deferred to AWS D1.1 for definition of effective area of fillet welds.
- J2.2b Limitations
 Revised *maximum size of fillets* to allow less than 1/16 in. between toe of weld and edge of base material where weld size is clearly verifiable, and to exempt flange-web fillet welds from the minimum weld size table.
 Added a provision for maximum effective length of fillet welds, forces parallel to leg, limited to 70 times leg size.
 Rewrote and expanded material now in *fillet weld terminations*, previously in *side or end fillet welds*.
- J2.4 Design Strength
 Added reference to Appendix J2.4 for alternative calculation of strength of fillet welds loaded in-plane.
- J3 BOLTS AND THREADED PARTS
 Some paragraph deletions and renumbering.
- J3.1 High-Strength Bolts
 Added provision to use “alternative design bolt” for providing required bolt tension.

- Added the following: “When A490 bolts over one inch in diameter are used in slotted or oversize holes in external plies, a single hardened washer conforming to ASTM F436, except with 5/16-in. minimum thickness, shall be used in lieu of the standard washer.”
(Moved from old J3.7e.)
Added requirement for bearing check for slip-critical connections with loading toward edge of connected part. (Repeated this in J3.2.)
- J3.2 Size and Use of Holes (old J3.7)
Some requirements relocated as indicated above.
- J3.3 Minimum Spacing (Old J3.9)
Requirements for spacing along a line of transmitted forces was revised and moved to J3.10.
- J3.4 Minimum Edge Distance (Old J3.10)
Requirements for edge distance along a line of transmitted forces revised and moved to J3.10.
- J3.5 Maximum Spacing and Edge Distance (Old J3.11)
Limitations on spacing of connectors between elements of weathering steel moved here from old E4, with limitations on edge distance for such connectors deleted.
Limitations for members not subject to corrosion added.
- J3.6 Design Tension or Shear Strength (Old J3.3)
Rewritten and clarified.
- J3.7 Combined Tension and Shear in Bearing-Type Connections (Old J3.4)
Interaction equations in Table J3.5 (old table J3.3) revised significantly.
- J3.8 High-Strength Bolts in Slip-Critical Connections (Old J3.5)
Rewritten and expanded to include design at either service loads (8a) or factored loads (8b). Provisions for the latter were referred to Appendix J3.8b.
Provisions for tension combined with shear moved to J3.9.
- J3.9 Combined Tension and Shear in Slip-Critical Connections (Part of Old J3.4)
Rewritten and expanded to include design at either service loads (9a) or factored loads (9b).
Provisions for the latter were referred to Appendix J3.9b.
- J3.10 Bearing Strength at Holes (Old J3.6)
Completely rewritten with several new equations, including bolts not at the nearest edge.
- J3.11 Long Grips (Old J3.8)
No changes.
- J4 DESIGN RUPTURE STRENGTH
Rewritten and expanded into three subsections (shear, tension, and block shear from old J5) with equations added.
- J5 CONNECTING ELEMENTS
- J5.2 Design Strength of Connecting Elements in Tension
Provisions for block shear moved to J4 and put in equation form.
Provisions for other connecting elements moved to J5.3 with changes.
- J5.3 Other Connecting Elements
New section moved from old J5.2 with changes in numerical coefficient and phi factor.
- J6 FILLERS
Added a provision whereby fillers $\frac{1}{4}$ to $\frac{3}{4}$ in. thick need not be developed if design shear strength of bolts is reduced by relationship given.
- J8 BEARING STRENGTH
Equation for bearing strength on milled surfaces revised to reduce strength.
Equations for bearing strength of rollers and rockers revised to reduce strength.
- J10 ANCHOR BOLTS AND EMBEDMENTS
Revised to eliminate technical content and instead refer to ACI or PCI criteria.

CHAPTER K - SPECIAL DESIGN CONSIDERATIONS

K1 WEBS AND FLANGES UNDER CONCENTRATED FORCES

- K1.1 Design Basis
Rewritten.
- K1.2 Local Flange Bending
Extended application to both “single-concentrated forces and the tensile component of double-concentrated forces.”
Specifically required stiffeners to be added when required strength exceeds that of the flange.
Added: “If the length of loading measured across the member flange is less than $0.15b$, where b is the member flange width, Equation (K1-1) need not be checked.”
Added provision to reduce strength when force is applied near beam end.
Added welding requirements for stiffeners.
- K1.3 Local Web Yielding
Extended application to both “single-concentrated forces and both components of double-concentrated forces.”
Specifically required stiffeners to be added when required strength exceeds that of the flange.
Added welding requirements for stiffeners.
- K1.4 Web Crippling
Extended application to both “single-concentrated forces and the tensile component of double-concentrated forces.”
Specifically required stiffeners to be added when required strength exceeds that of the flange.
For condition where force is applied near the member end, split into two cases and added new equation.
Added welding requirements for stiffeners.
- K1.5 Sidesway Web Buckling
Complete revision with new equations.
- K1.6 Compression Buckling of Web
Added applicability sentence and welding requirements for stiffeners.
- K1.7 Panel-Zone Web Shear
Complete revision with new strength equations.
- K1.8 Unframed Ends of Beams and Girders
Short section requiring stiffeners at certain unframed ends.
Much of old K1.8 was integrated back into the above sections and K1.9.
- K1.9 Additional Stiffener Requirements for Concentrated Forces.
New section providing details on stiffener design.
- K1.10 Additional Doubler Plate Requirements for Concentrated Forces.
New section providing details on doubler plate design.

K3 FATIGUE

- Old K3, Torsion, which referenced H2, was eliminated.
- New K3 same as old K4.

CHAPTER M - FABRICATION, ERECTION AND QUALITY CONTROL

M2 FABRICATION

- M2.1 Cambering, Curving and Straightening
Added that the temperature A852 steel should not exceed 1100°F .

M3 SHOP PAINTING

- M3.1 General Requirements
Revised to state that shop paint is not required unless specified in the contract.
- M3.3 Contact Surfaces
Updated with new provisions for slip-critical connections.

- M4 ERECTION
 - M4.5 Field Welding
Reworded.
- M5 QUALITY CONTROL
 - M5.3 Inspection of Welding
Exceptions to AWS noted.

APPENDIX B - DESIGN REQUIREMENTS

- B5 LOCAL BUCKLING
 - Divided into three subsections instead of two with renumbering.
 - B5.1 Classification of Steel Sections
 - New section with equations added for limit state of web local buckling.
 - B5.3a Unstiffened Compression Elements
 - Equations added for flanges, angles and plates projecting from built-up columns or other compression members.
 - Eliminated table for limiting proportions of unstiffened tee elements.
 - B5.3c Design Properties
 - Last part of section moved to new B5.3d.
 - B5.3d Design Strength
 - New section containing provisions for axially loaded members, previously in old B3c.

APPENDIX E – COLUMNS AND OTHER COMPRESSION MEMBERS

- E3 FLEXURAL-TORSIONAL BUCKLING
 - Revised introductory paragraph.

APPENDIX F - BEAMS AND OTHER FLEXURAL MEMBERS (Appendix D)

- F1 DESIGN FOR FLEXURE
 - Equation for C_b deleted with reference to main body for new equation.
 - Tables of nominal strength requirements include several revisions, addition of equations, etc.
- F2 DESIGN FOR SHEAR
 - New section with requirements for design shear strength of stiffened or unstiffened webs, and for transverse stiffeners.

APPENDIX G – PLATE GIRDERS

- G2 DESIGN FLEXURAL STRENGTH
 - Factor R_{pG} removed from equation for tension flange yielding.
 - Equation for C_b deleted with reference to main body for new equation.
- G4 TRANSVERSE STIFFENERS
 - Factor j used for calculating required moment of inertia of stiffeners moved to F2.3.

APPENDIX H – MEMBERS UNDER TORSION AND COMBINED FORCES

- H3 Definitions of terms for interaction equations now defined for (a) I-shaped members, with clarifications in equations, and (b) box-section members, new.

APPENDIX J – CONNECTIONS, JOINTS, AND FASTENERS

- Entirely new section with contents as follows.
- J2 WELDS
 - Alternative provisions for design strength of fillet welds.
- J3 BOLTS AND THREADED PARTS
 - Provisions for design of slip-critical connections using factored loads.

APPENDIX K - STRENGTH DESIGN CONSIDERATIONS

K3 FATIGUE (Old K4)

- K3.1 Loading Conditions; Type and Location of Material
Table A-K4.3 revised to include eyebars and pin plates.
Figure A-K3.1 revised to include eyebars and pin plates, details 28 and 29.

NUMERICAL VALUES

General update in line with *Specification* changes.

January 30, 1998 Supplement No. 1 to LRFD Specification

A3 MATERIAL

- A3.1a ASTM Designations
Added A913 steel, "High-Strength Low-Alloy steel Shapes of Structural Quality, Produced by Quenching and Self-Tempering Process (QST)."

CHAPTER B – DESIGN REQUIREMENTS

B5 LOCAL BUCKLING

- B5.1 Deleted footnote e in Table B5.1 regarding residual stresses and replaced it with "For members with unequal flanges, use h_p instead of h when comparing to λ_p ."
B5.1(b) Added definition for web depth h_p .

B10 PROPORTIONS OF BEAMS AND GIRDERS

Revised to refer to proportioning by the "flexural strength" of the gross section.
Net area rule clarified to pertain to tension flange.
Added that flexural strength shall be based on the elastic section modulus if the effective tension flange area is used.

CHAPTER I – COMPOSITE MEMBERS

I1 DESIGN ASSUMPTIONS

In the definition of elastic analysis, computation of stiffness, changed wording to "weighted average of the moments of inertia in the positive and negative moment region."
Added definitions for Encased Composite Column and Filled Composite Column.

I2 COMPRESSION MEMBERS

- I2.1 Limitations
Raised rebar maximum yield stress for composite columns from 55 to 60 ksi.

I3 FLEXURAL MEMBERS

- I3.3 Design Strength of Concrete-Encased Beams
Requirements added for design based on plastic stress distribution on the composite section.

I5 SHEAR CONNECTORS

- I5.6 Shear Connector Placement and Spacing
Revised wording regarding min. spacing with deck ribs perpendicular to beam.

CHAPTER J – CONNECTIONS, JOINTS, AND FASTENERS

J1 GENERAL PROVISIONS

- J1.9 Bolts in Combination with Welds
Revised to require calculations at factored loads.

J2 WELDS

- J2.2b Limitations
Revised limitation for lap joints to apply to joints that utilize transverse fillet welds only.
Rewrote rules for fillet weld terminations.

- J3 BOLTS AND THREADED PARTS
 - J3.8 High-Strength Bolts in Slip-Critical Connections
Moved service-load provisions to the Appendix and factored-load provisions to the main chapter.
 - J3.9 Combined Tension and Shear in Slip-Critical Connections
Moved service-load provisions to the Appendix and factored-load provisions to the main chapter.
 - J3.10 Bearing Strength at Bolt Holes
Significant revisions made in this section for consistency with the 1994 RCSC LRFD Specifications.

APPENDIX J – CONNECTIONS, JOINTS, AND FASTENERS

- J3 BOLTS AND THREADED PARTS
 - J3.8 High-Strength Bolts in Slip-Critical Connections
 - J3.8b Slip-Critical Connections Designed at Service Loads
Service-load provisions were moved to the Appendix from the main chapter and factored-load provisions were moved to the main chapter.
 - J3.9 Combined Tension and Shear in Slip-Critical Connections
 - J3.9b Slip-Critical Connections Designed at Service Loads
Service-load provisions were moved to the Appendix from the main chapter and factored-load provisions were moved to the main chapter.

December 27, 1999 Load and Resistance Factor Design Specification for Structural Steel Buildings

The contents of *Supplement No. 1* were included in the revised *Specification* and revisions were made as indicated below. Throughout the document, where traditional units were given in the text, metric equivalents were added, and equations that were unit dependant were expressed in dimensionless form or equivalent metric equations were added. Similarly, metric equivalents were added in all tables, or corresponding metric tables were inserted.

- A1 SCOPE
The scope was expanded to indicate that the *Specification* includes the symbol list, glossary, and appendices. Seismic design, single angle member design, and hollow structural sections (HSS) design was referred to separate AISC specifications. Also, material was moved here from old A2.1.
- A2 TYPES OF CONSTRUCTION
Renamed and old A2.1 moved to A1.
Added more detail on requirements for Type PR construction analysis and design.
Deleted statement on self-limiting deformation of PR construction.
- A3 MATERIAL
 - A3.1 Structural Steel
Added A992/A992M steel.
Added ASTM metric designations.
 - A3.2 Steel Castings and Forgings
Added ASTM metric designations.
 - A3.3 Bolts, Washers, and Nuts
Added Hardened Steel Washers, F436 and F436M; Direct Tension Indicators, F959 and F959M, and “Twist Off” Assemblies, F1852.
Added ASTM metric designations.
 - A3.4 Anchor Bolts and Threaded Rods
Added F1554 anchor bolts.
Added ASTM metric designations.
 - A3.5 Filler Metal and Flux for Welding

Added Electrodes for Electrode Gas Welding AWS A5.26/A5.26M; and Welding Shielding Gases, AWS A 5.32/A5.32M.
Added AWS metric designations.

- A4 LOADS AND LOAD COMBINATIONS
Deleted most of section by reference to applicable codes or ASCE 7 in the absence of a code.
- A6 REFERENCED CODES AND STANDARDS
General update with references added to numerous documents from various sources.

CHAPTER B – DESIGN REQUIREMENTS

- B3. EFFECTIVE NET AREA OF TENSION MEMBERS
Section reorganized; “bolts or rivets” changed to “fasteners or welds.”
- B5 LOCAL BUCKLING
B5.1 Classification of Steel Sections
In Table 5.1, Limiting Width-Thickness Ratios for Compression Elements, relationships written in terms of E to make them dimensionless.
Added provision for the width of HSS such that the wall thickness may be taken as 0.93 times the nominal wall when the design thickness is unknown.
- B9 END RESTRAINT
Section rewritten.
- B10 PROPORTIONS OF BEAMS AND GIRDERS
Rules for length of cover plate termination welds put in equation form.

CHAPTER C – FRAMES AND OTHER STRUCTURES

- C1 SECOND ORDER EFFECTS
Section divided into two parts; P_{e1} and P_{e2} redefined.
- C2 FRAME STABILITY
C2.1 Braced Frames
Limitation on axial force in structures designed on the basis of plastic analysis moved to C2.1a.
C2.2 Unbraced Frames
Limitation on axial force in structures designed on the basis of plastic analysis moved to C2.2a.
- C3 STABILITY BRACING
This is a new section added to give comprehensive provisions for bracing design.

CHAPTER D – TENSION MEMBERS

- D3 PIN-CONNECTED MEMBERS AND EYEBARS
This section was reorganized but technical provisions were unchanged.

CHAPTER E – COLUMNS AND OTHER COMPRESSION MEMBERS

- E4 BUILT-UP MEMBERS
This section was reorganized but technical provisions were unchanged.

CHAPTER G – PLATE GIRDERS

This brief five-sentence chapter, which refers to the Appendix for design provisions, was modified to more clearly distinguish between various types of girders.

CHAPTER I – COMPOSITE BEAMS

I2 COMPRESSION MEMBERS

I2.4 Load Transfer

Requirements added for design of shear connectors in composite columns.

CHAPTER J – CONNECTIONS, JOINTS, AND FASTENERS

J2 WELDS

Added requirement that “length and disposition of welds, including end returns shall be indicated on the design and shop drawings.”

J2.2 Fillet Welds

J2.2b Limitations

Revised *maximum effective length of fillet welds*, forces parallel to leg, from 70 times leg size to 100 times leg, with transition equation for up to 300 times leg, where the reduction factor is 0.60.

J2.4 Design Strength

In Table J2.5, Design Strength of Welds, added footnote providing alternative design provision (treat as partial-joint-penetration weld) for certain CJP welds (see J2.6 below) when weld metal without toughness requirements is used.

J2.6 Weld Metal Requirements

Added requirement for weld metal with Charpy V-notch toughness of 20 ft-lbs at 40°F for (a) CJP welds with backing left in place, tension normal to effective area, and (b) CJP welds, tension normal to effective area, Group 4 and 5 shapes and built-up shapes with plates over 2-in. thick.

J3 BOLTS AND THREADED PARTS

Added metric equivalents in all tables, or inserted corresponding metric table.

J3.2 Size and Use of Holes

Deleted redundant reference to J3.10.

J4 DESIGN RUPTURE STRENGTH

J4.3 Block Shear Rupture Strength

Added lower limit to both equations, based on ultimate strength along shear and tension areas.

J6 FILLERS

Provisions restated.

CHAPTER M - FABRICATION, ERECTION AND QUALITY CONTROL

M2 FABRICATION

M2.2 Thermal Cutting

Revised references to AWS.

CHAPTER N – EVALUATION OF EXISTING STRUCTURES

This is a new chapter that applies to evaluation of strength and stiffness by structural analysis, load tests, or a combination thereof, when specified by the Engineer of Record. It is restricted to static, gravity loads.

APPENDIX J – CONNECTIONS, JOINTS, AND FASTENERS

J3 BOLTS AND THREADED PARTS

J3.8 High-Strength Bolts in Slip-Critical Connections

Provisions for design at factored loads moved with revisions to main body, J3.8.

Provisions for design at service loads moved here with revisions from main body.

J3.9 Combined Tension and Shear in Slip-Critical Connections

Provisions for design at factored loads moved with revisions to main body, J3.9.

Provisions for design at service loads moved here with revisions from main body.

APPENDIX K – CONCENTRATED FORCES, PONDING, AND FATIGUE

K2 PONDING

Removed 0.95 factor from stress index equations.

K3 DESIGN FOR CYCLIC LOADING (FATIGUE)

This section was rewritten with rearrangement of subheadings (1 through 5) and significant revisions. Previously there were four loading conditions to select from, based on number of cycles. Then, the design stress range corresponding to eight stress categories (A, B, B', C, D, E, E', and F) was selected from a table for loading conditions 1 to 4. Under the revised provisions, the design stress range is calculated from an equation that typically involves a fatigue constant, C_f , and a threshold fatigue stress range, F_{TH} . These terms for each detail (stress category) are selected from a table. A new category C'' was added.

K3.5 Special Fabrication and Erection Requirements

This new section includes requirements related to backing bars, reinforcing fillets, surface roughness, re-entrant corners, run-off tabs, and fillet weld terminations.

Appendix A2

HISTORICAL REVIEW OF AISC MANUAL – 1927 TO 1995

Following is a summary of all printings of the AISC *Manual of Steel Construction*.

Edition and Printing*	Date	Date of Included AISC Specification	Date of Included AISC Code of Standard Practice
A. ASD Manuals			
1 st Ed., 1 st Printing	Dec. 1927	6-1-23	10-1-24
1 st Ed., 2 nd Printing	Mar. 1928	6-1-23	10-1-24
1 st Ed., 3 rd Printing	May 1928	6-1-23	10-1-24
1 st Ed., 4 th Printing	Dec. 1928	11-1-28	1928
1 st Ed., 5 th Printing	Apr. 1929	11-1-28	1928
1 st Ed., 6 th Printing	Jan. 1930	11-1-28	1928
1 st Ed., 7 th Printing	Apr. 1930	11-1-28	1928
1 st Ed., 8 th Printing	Dec. 1930	11-1-28	1928
1 st Ed., 9 th Printing	Jan. 1932	11-1-28	1928
1 st Ed., 10 th Printing	Oct. 1932	11-1-28	1928
2 nd Ed., 1 st Printing	Jan. 1934	1-34	1-34
2 nd Ed., 2 nd Printing	Jan. 1934	1-34	1-34
2 nd Ed., 3 rd Printing	May 1936	1-34	1-34
2 nd Ed., 4 th Printing	May 1936	1-34	1-34
3 rd Ed., 1 st Printing	Oct. 1937	1-37	1-37
3 rd Ed., 2 nd Printing	1939	1-37	1-37
3 rd Ed., 3 rd Printing	1940	1-37	1-37
3 rd Ed., 4 th Printing	1941	1-37	1-37
4 th Ed., 1 st Printing	1941	7-41	7-41
4 th Ed., 2 nd Printing	1942	7-41	7-41
4 th Ed., 3 rd Printing	1943	7-41	7-41
4 th Ed., 4 th Printing	1944	7-41	7-41
4 th Ed., 5 th Printing	1945	7-41	7-41
5 th Ed., 1 st Printing	1946	2-46	11-1-45
5 th Ed., 2 nd Printing	1947	2-46	12-1-46
5 th Ed., 3 rd Printing	1947	2-46	12-1-46
5 th Ed., 4 th Printing	1947	2-46	12-1-46
5 th Ed., 5 th Printing	1948	2-46	12-1-46
5 th Ed., 6 th Printing	1948	2-46	12-1-46
5 th Ed., 7 th Printing	1948	2-46	12-1-46
5 th Ed., 8 th Printing	1949	2-46	12-1-46

5 th Ed., 9 th Printing	1949	2-46	12-1-46
5 th Ed., 10 th Printing	1950	6-23-49	12-1-46
5 th Ed., 11 th Printing	1951	6-23-49	12-1-46
5 th Ed., 12 th Printing	1951	6-23-49	12-1-46
5 th Ed., 13 th Printing	1952	6-23-49	12-1-46
5 th Ed., 14 th Printing	1952	6-23-49	6-26-52
5 th Ed., 15 th Printing	1953	6-23-49	6-26-52
5 th Ed., 16 th Printing	1954	6-23-49	6-26-52
5 th Ed., 17 th Printing	1955	6-23-49	6-26-52
5 th Ed., 18 th Printing	1955	6-23-49	6-26-52
5 th Ed., 19 th Printing	1956	6-23-49	6-26-52
5 th Ed., 20 th Printing	1956	6-23-49	6-26-52
5 th Ed., 21 st Printing	1957	6-23-49	6-26-52
5 th Ed., 22 nd Printing	1957	6-23-49	6-26-52
5 th Ed., 23 rd Printing	1958	6-23-49	6-26-52
5 th Ed., 24 th Printing	1959	6-23-49	6-26-52
5 th Ed., 25 th Printing	1959	6-23-49	6-26-52
5 th Ed., 26 th Printing	1960	6-23-49	6-26-52
5 th Ed., 27 th Printing	1961	6-23-49	6-26-52
5 th Ed., 28 th Printing	1961	6-23-49	6-26-52
5 th Ed., 29 th Printing	1962	6-23-49	6-26-52
5 th Ed., 30 th Printing	1962	6-23-49	6-26-52
6 th Ed., 1 st Printing	July 1963	4-17-63	2-20-63
6 th Ed., 2 nd Printing	Aug. 1963	4-17-63	2-20-63
6 th Ed., 3 rd Printing	Dec. 1963	4-17-63	2-20-63
6 th Ed., 4 th Printing	Mar. 1964	4-17-63	2-20-63
6 th Ed., 1 st Revised P.	Apr. 1965	4-17-63	2-20-63
6 th Ed., 2 nd Revised P.	Nov. 1965	4-17-63	2-20-63
6 th Ed., 3 rd Revised P.	Mar. 1966	4-17-63	2-20-63
6 th Ed., 4 th Revised P.	Mar. 1967	4-17-63	2-20-63
7 th Ed., 1 st Printing	1970	2-12-69	6-1-70
7 th Ed., 1 st Revised P.	1973	2-12-69	10-1-72
		Supplement 1, 11-1-70	
		Supplement 2, 12-8-71	
8 th Ed., 1 st Printing	1980	11-1-78	9-1-76
		Supplement 1, 3-11-86	
		Supplement 2, 1-1-89	
8 th Ed., 2 nd thru 11 th Impressions	9-80 thru 4-84	Same as above.	9-1-76
8 th Ed., 1 st Revised P.	Nov. 1984	Same as above.	9-1-76
8 th Ed., 2 nd Revised P.	Sept. 1987	Same as above.	9-1-76
8 th Ed., 3 rd Revised P.	Mar. 1988	Same as above.	9-1-76
9 th Ed., 1 st Printing	July 1989	6-1-89	9-1-86
9 th Ed., 2 nd Impression	Sept. 1989	6-1-89	9-1-86
9 th Ed., 3 rd Impression	Jan. 1990	6-1-89	9-1-86
9 th Ed., 1 st Revision	Jan. 1991	6-1-89	9-1-86
9 th Ed., 2 nd Revision	Nov. 1995	6-1-89	9-1-86

B. LRFD Manuals

1st Ed., 1st Printing

Nov. 1986

9-1-86

9-1-86

Supplement 1, 1-1-89

2nd Ed., 1st Printing

1994

12-1-93

6-10-92

* "Edition" indicates general update for new Specification. "Printing" indicates changes made due to a *Supplement* issued to the *Specification* or to update or correct material in the *Manual*. "Impression" indicates reprinting with no or minor changes.

Appendix A3

HISTORICAL REVIEW OF RCSC SPECIFICATIONS – 1951 TO 2000

The review of specifications through 1988 is based on the paper, "History of the Development of High-Strength Bolting Specifications," by Robert F. Lorenz. The review of the specification for 2000 is based on an article by Charles J. Carter and Heath E. Mitchell, "Revised RCSC Specification: Simplified, Clarified, and Improved," *Modern Steel Construction*, April 2001.

Background. As early as 1934 in Great Britain, it was noted that bolts with higher yield strengths could prevent slip in connected steel material. In the United States, University of Illinois reported in 1938 that pre-tensioned high-strength bolts could achieve a fatigue life at least as good as a rivet. After World War II, many riveted railroad bridges required maintenance due to the intensive wartime service, particularly missing or defective rivets. It was also realized that compared to riveting, bolt substitution was safer, quicker, and more economical. This situation was the genesis of the development of the high-strength bolt.

The Research Council on Riveted and Bolted Structural Joints (RCRBSJ) was formed in 1947 to develop specifications for connections with high-strength bolts. In 1980 it was renamed the Research Council on Steel Connections (RCSC). Successive editions of the specifications developed are reviewed in the following paragraphs.

1951. The original rules for high-strength bolts were issued by the RCRBSJ in January 1951 as *Specifications for Assembly of Structural Joints Using High Tensile Steel Bolts*. This brief four-page document had five sections: 1. Scope, 2. Bolts, Nuts and Washers, 3. Bolted Parts, 4. Assembly, and 5. Inspection. There were three tables covering bolt lengths, bolt dimensions, and a tension-torque table. It identified the ASTM A325 high-strength bolt as equivalent to a hot driven ASTM 141 rivet.

1954. The document was revised and reissued in February 1954. With the addition of Appendix A and B, it was expanded to eight pages. Appendix A was merely a reworking of the nominal

dimensions for bolts but now included dimensions for the nut. Appendix B was extensive and was the forerunner of the current Commentary to the Specification. It covered ten technical issues:

- Interpretation of the rule covering substitution of one bolt for one rivet.
- Effect on compression members.
- Effect of external axial load on bolt tension.
- Low alloy and high-strength structural steels.
- Painted contact surfaces.
- Galvanized structural steel.
- Tightening beyond the minimum proof load.
- Wrenching the bolt head instead of the nut.
- Tension control by rotation of the nut.
- Use of high-strength bolts for fitting up.

1960. The third version had a new title, *Specification for Structural Joints Using ASTM A325 Bolts*. Issued in March 1960, it was expanded to 16 pages, including a ten page Commentary. In the scope, the designations of friction-type and bearing-type connections were introduced. This revision also included a new Section 4, Allowable Working Stresses, that brought in the concept of "basic design stress" from which applied tension, shear (threads included and excluded), and bearing design values were derived. Reference to bolt substitutions for rivets was completely eliminated, although the shear value for friction-type and bearing-type connections with threads included still matched the rivet value of 15 ksi. The section on Assembly was now titled Installation and the calibrated-wrench and turn-of-nut methods were described. Torque values were eliminated from the bolt tension table. Eleven technical references were listed at the end of the Commentary.

1962. The fourth revision was issued in March 1962. The term "prying action" was introduced under applied tension criteria and the 10-second

limit on impact wrench use was mentioned. Rules for use of washers were clarified and the technical reference list was tied to the text through footnotes.

1964. The March 1964 edition, *Specification for Structural Joints Using ASTM A325 or A490 Bolts*, marked the introduction of the ASTM A490 quenched and tempered alloy steel bolt. This increased the need for washers when the bolted-up material had a specified yield point less than 40 ksi. This also brought the need for a new table of allowable working stresses for fasteners. A490 bolts in tension were limited to static loading. The bearing limit for design was now designated as $1.35 F_y$ based on the yield point of the connected material.

1966. The sixth version issued September 1, 1966 had few changes but included an introductory message answering questions comparing the A490 bolt with the earlier ASTM A354, grade BC material, which was similar but not cited in the Specification. A490 bolt limits were reduced to lower values in both tension and friction-type shear.

1970. Important changes were included in the March 31, 1970 version. This included the introduction of enlarged and slotted holes with certain limitations. Three approved contact surfaces for friction-type connections were introduced, based on prescriptive rules. The Commentary recognized three types of A325 material, Types 1, 2, and 3. The use of galvanized A325 bolts was approved but was not recommended for A490 bolts.

1972. The eighth publication of the Specification was April 18, 1972. New specific terminology identified the oversize hole, the short slotted hole, and the long-slotted hole. The direct tension indicator method of installation was added.

1974. The major change in the May 8, 1974 version was an expansion of Table 4 to a 3 x 3 matrix of varying bolt lengths and bevels in determining the nut rotation for the turn-of-the nut method.

1976. Major changes marked the publication of the tenth revision dated February 4, 1976 and distributed in June of that year. All allowable stresses were increased from 10 to 40 percent based on research programs that recognized the true strength of the high-strength bolt rather than

a substitute fastener for a rivet. The bearing value of the bolted material was now made a function of tensile strength rather than yield strength, resulting in higher values. Specific strength values were assigned to oversize and slotted hole types. Limitations on reuse of bolts were introduced for friction type connections. Ten classes of surface condition of the bolted parts were recognized, each with prescribed working stresses for each hole type for both bolt grades, ASTM A325 and ASTM A490. Reductions in allowable stresses were now included based upon fatigue life.

1978. The eleventh re-issue of the bolt specification was made available on April 26, 1978. An important rule change here was the recognition that all friction connections needed to also be checked for bearing strength. Previously, when bearing limits were lower, it was presumed that the bearing stress check in friction connections could be omitted because of the high pretension present

1980. The twelfth version of the Specification was dated August 14, 1980 under the new name for the group, Research Council on Structural Connections. The inclusion of ASTM F436 introduced a new standard for hardened washers. Prying action was limited to 60 percent of the external tensile load, and there were new reductions of allowable tension based on fatigue life. The calibrated wrench method was dropped, and the need for the inspecting torque wrench was limited to arbitration situations. The Commentary listed a new section titled Connection Behavior, which emphasized design limits determined by new research information on "shear lag" and "web tearout".

1985. The thirteenth edition dated November 13, 1985, is the document that appeared in the 1989 *AISC Manual*, 9th Ed. This version included a preface that described the purpose and membership of the council. The language in the scope and the format of the entire document were improved. Approved materials for the bolted assembly were clarified, while paint and load indicating devices were mentioned. The use of the designations "friction-type" and "bearing-type" connections was discontinued. Rather, all connections were considered bearing (strength design) and certain of these might be required to be "slip-critical" (service design). A new section provided a design check for the slip-critical case. A significant change in installation procedures was the relaxation of the pretension requirement.

For those bolts not subject to tension loads, or loosening and fatigue due to vibration or load fluctuations, snug-tight tightening was sufficient. This was a positive breakthrough for bolted connection economy. Allowable loads for slip-critical connections were classified for contact surfaces rated as Class A (slip coefficient of 0.33), Class B (slip coefficient of 0.50), and Class C (slip coefficient of 0.40). For other conditions, Appendix A provided a test method to determine slip coefficients for other coatings or surfaces. The calibrated wrench method of installation was reinstated with modifications to achieve better control.

1988. A specification in LRFD format was approved June 8, 1988. In Section 4, Design of Bolted Connections, all tables, equations and terminology were revised from the allowable stress design approach to that of the LRFD method. This included a complete rewriting of the section on slip resistance to include procedures for the design of slip-critical bolts with either nominal (service) loads or factored (strength) load criteria. Other changes were mostly clarifications in the text, particularly, on the understanding as to whether shear/bearing connections would be snug-tight or fully pretensioned.

1994. New editions were issued in both ASD and LRFD formats. The revisions to the ASD Specification were only in Appendix A, "Testing Method to Determine the Slip Coefficient for Coatings Used in Bolted Joints," which was made consistent with the corresponding information in the LRFD Specification. The preface encouraged the use of the LRFD Specification, which had been updated to reflect new information. The numerous updates to the LRFD Specification included the following:

- ASCE 7-93 was referenced for load criteria.
- In accord with changes in the ASTM specifications, Type 2 bolts (low carbon martensitic steel) were dropped from both A325 and A490.
- Burrs that are acceptable for snug tight conditions were defined as 1/16 in. or less.
- The format for the limit state of combined tension and shear was revised by the introduction of a specific interaction equation. Previously, reductions in tension design strength in bearing connections were only made when the applied shear

force exceeded 1/3 the design shear strength.

- The equations for the bearing strength limit state were changed and stated in terms of the clear distance from the edge of the hole rather than from the center of the hole.
- In the equation for the nominal slip resistance of slip-critical joints designed at the nominal-load level, changes were as follows: D , the slip probability factor, was set at 0.80 (previously 0.81 to 0.86) and μ , the slip coefficient for Class C surfaces, was set at 0.35 (previously 0.40).
- Under washer requirements, it was specifically stated that a washer shall be installed over a slotted hole that occurs in an outer ply; a similar clause was previously under installation and tightening.
- For installation of bolts using direct tension indicator tightening, provisions for indicators other than those meeting ASTM F959 were deleted.
- Some minor changes were made in Appendix A, "Testing Method to Determine the Slip Coefficient for Coatings Used in Bolted Joints," based on experience with the method.

2000. This edition of the Council's *Specification for Structural Joints Using ASTM A325 or A490 Bolts* was significantly reorganized and revised from earlier editions. Major changes included the following:

- The previously separate LRFD and ASD versions of the Specification were unified, with LRFD as the basis in the main body and ASD as an alternative in Appendix B.
- Three sections were added: Symbols (nomenclature), Glossary, and an Index.
- Commentary information was placed immediately following its corresponding Specification provision to provide convenient reference to background and further explanation.
- A summary of the drawing information and approvals required from the Engineer of Record was added in Section 1.4.
- Requirements specific to fastener components have been grouped into Section 2. Explicit coverage of material and geometric requirements for washer-type indicating devices, twist-off-type tension-control bolt assemblies and

alternative design fasteners were added in Sections 2.6, 2.7, and 2.8, respectively.

- Requirements specific to the parts that are connected have been grouped into Section 3. Provisions allowing the thermal cutting of bolt holes with the approval of the Engineer of Record were added in Section 3.3. Requirements for the treatment of burrs were clarified and expanded in Section 3.4.
- New information was added in Section 4 to address the applicability and suitability of the various joint types: snug-tightened joints, pretensioned joints, and slip-critical joints. The requirements in this Section also serve to identify the applicable design, installation and inspection requirements for each of the joint types.
- Design requirements have been grouped into Section 5. Requirements were added to Section 5.1 to address the design implications of the presence of fillers or

shims. In Section 5.5, the limitation on prying force for applications that involve tensile fatigue was reduced from 60 percent of the total applied load to 30 percent.

- Washer requirements were simplified and clarified in Section 6.
- Provisions for pre-installation verification of fastener assemblies were clarified in Section 7, as invoked in Section 8.2 for pretensioned joints and slip-critical joints.
- Installation requirements were simplified and clarified significantly in Section 8.
- Inspection requirements in Section 9 were significantly expanded to clarify the intent and applicability.
- Arbitration provisions to be used in the case of a dispute were clarified in Section 10.

Appendix A4

HISTORICAL REVIEW OF AWS SPECIFICATIONS – 1934 TO 1999

The review of specifications through 1980 is based on notes entitled, “Welding History in AISC Manual,” by Robert F. Lorenz.

Background. When the 1927 *AISC Manual*, 1st Ed., was published, there was virtually no mention of welding as a technique for connecting structural steel members. All references to connecting steel parts was limited to rivets or common bolts. Information on welding first appeared in 1934 and accelerated rapidly after 1945.

1934. In the 1934 *AISC Manual*, 2nd Ed., a single page of information reprinted extracts from an American Welding Society document. This included a cautionary note on the importance of experience both in design and process. Limiting stresses from the American Welding Society (AWS) for the throat of the weld were listed as: Shear – 11,300 psi, Tension – 13,000 psi, and Compression – 15,000 psi. Much of the welding at this time used bare wire electrodes and the lack of protecting fluxes often resulted in brittle welds.

1939. The 1939 *AISC Manual*, 3rd Ed., changed the limiting stress for compression from 15,000 psi to 18,000 psi. Also, a second page was added showing welding nomenclature and notation. There were still no specified rules or guidance for welding in the *AISC Specification* and weld details for building construction was virtually non-existent.

1941. The 1941 *AISC Manual*, 4th Ed., included the welding information from the previous edition, but eliminated all mention of AWS limiting stresses. Apparently the years of the Great Depression did not allow for the technical development of welding, but this was soon to change.

1946. The knowledge of arc welding obtained during World War II eliminated many of the barriers to welding acceptance. Tentative rules for welding of structural steel were established in the 1946 *AISC Manual*, 5th Ed. Information on welding expanded to seven pages, made up of a single page of background text, three pages of tentative standard details, two pages of AWS welded joint descriptions, and a page on welding symbols.

More importantly, the 1946 *AISC Specification* now included guidance for welding of structural steel. Within the *Specification*, all references to welding pointed to AWS as a source (Section 2). Section 5 required qualification tests for operators and set criteria for welds in combination with rivets and bolts. Section 7(e) indicated that field connections were required to be made with rivets or welds. Section 9 mentioned six Electrode Classification Numbers to be specified, all in the 60 class. In section 15, Allowable Unit Stresses, compression and tension in butt welds was raised to 20,000 psi, while shear in a fillet or slot weld was limited to 13,600 psi and shear in a butt weld limited to 13,000 psi. The 50 percent increase in the tension value for butt welds (from 13,000 to 20,000 psi) opened the door for economical field welded moment connections. Sections 24 and 25 were completely devoted to welding details and limitations of geometry. Finally, in Section 33, rules of workmanship to obtain quality welded fabrication was specified.

1961-1963. The 1963 *AISC Manual*, 6th Ed., included the 1961 *AISC Specification* with changes that introduced many new opportunities for structural welding economy. Most important were the new steels. Two new carbon steels became available, A36 and A373. Both provided chemistry limits on carbon and manganese to enhance weldability. A373 was aimed at steel bridge applications, but ductility improvements in A36 eventually led to the discontinuance of A373. In addition to better weldability, the increased strength of A36 over A7 allowed for the use of E70 electrodes; this led to further economies because the shear value with E70 electrodes increased from 13,600 psi to 15,800 psi. Three new steels with higher yield points were included: A242, A440 (for riveted and bolted applications), and A441. Both A441 and A242 (certain grades) were intended for welding and low hydrogen electrodes were required.

1969-1974. The 1970 AISC *Manual*, 7th Ed., and the 1969 AISC *Specification* provided further information relating joint type to material and weld strengths. The *Specification* provided a table showing, for each of the many steels now included (A36 through A514), what electrodes should be used for each of four processes: shielded metal-arc, submerged arc, gas metal-arc, and flux cored-arc welded. Matching base metal was defined. Significantly, the *Specification* increased the allowable shear stress to a value equal to 0.3 times the nominal tensile strength of the weld metal. For E70 electrodes used with steels ranging from A36 to A588, this increased the allowable shear stress to 21 ksi, a 1/3 increase over the 15.8 ksi value. This edition also marked the introduction of the electroslog and electrogas welding processes. In 1974, Supplement No. 3 to the *Specification* permitted weld metal with a strength level equal to or less than matching base metal, except for tension members.

1980. The 1980 AISC *Manual*, 8th Ed. and the 1978 AISC *Specification* saw a reduction of specific language regarding welding. Instead, much of the information on process and weld detail was covered by reference to the AWS D.1.1 *Structural Welding Code*. However, design information and material compatibility information was retained and clarified.

1986. Load and resistance Factor Design was introduced in the 1986 AISC *Specification* – LRFD and the 1986 AISC *Manual* – LRFD, 1st Ed. Design strengths to be used with factored loads were specified instead of the past allowable stresses. Reliance on the AWS D.1.1 *Structural Welding Code* for information on process and weld detail continued.

1989. The 1989 AISC *Manual* – ASD, 9th Ed., and the 1989 AISC *Specification* – ASD, maintained the same allowable stresses as in the past and continued reliance on AWS D.1.1. A852 steel was introduced.

1999. The 1999 LRFD *Specification* generally maintained the same design strengths as the 1986 *Specification*. However, changes included a new length reduction factor for end-loaded (i.e., longitudinal) fillet welds longer than 100 times the weld size; updated details for fillet weld terminations; and filler metal toughness requirements for certain CJP groove welded T and corner joints and splices of heavy shapes and heavy built-up shapes with tension normal to the effective area.

Appendix A5

HISTORICAL REVIEW OF AISC CODE OF STANDARD PRACTICE – 1924 TO 2000

Table A3 provides a chronology of the various editions of the AISC document now known as the *Code of Standard Practice for Steel Buildings and Bridges*. A description of the changes made in most of the revisions follows. Reference should be made to the original codes for complete details. The description of

developments through 1976 was taken from notes compiled by the late Frank W. Stockwell, Jr. The review of the March 7, 2000 *Code* was abstracted from an article by Charles J. Carter, “What’s New in the Updated Code,” *Modern Steel Construction*, August 2000.

Table A3
Chronology of Development of AISC Code of Standard Practice

Date	Action
Oct. 1, 1924	Adopted first <i>Code</i>
1927	Revision
1928	Revision
Jan. 1934	Revision (Editorial)
June 1937	Revision
June 1937	Revision (Editorial)
July 1941	Revision (Editorial)
Nov. 1, 1945	Revision
Dec. 1, 1946	Revision
June 26, 1952	Revision
Feb. 20, 1963	Revision
Sept. 14, 1966	Revision
July 1, 1970	Revision
Oct. 1, 1972	Revision
Sept 1, 1976	Complete Revision
Sept. 1, 1986	Revision
June 10, 1992	Revision
March 7, 2000	Adopted New <i>Code</i>

June 1, 1923 Adoption of first code

At this time the title was *Code of Standard Practice for Buildings*.

January 1934 Revision

The following sections were revised: 1(b), 3(a), 4(a), 4(e), 5(g), and 7(c).

June 1937 Revision

Several “Standard Documents” were added.

Nov. 1, 1945 Revision

The title was changed to *Code of Standard Practice for Buildings and Bridges*.

SECTION 2. CLASSIFICATION

Retained Class A Structural Steel and deleted Classes B, C, and D.

Added the following new subsections:

1(e) Patented Devices

6(a) Test of Materials

6(h) Marking and Shipping of Material Sold on a Delivered Basis

7(q) Final Cleanup

Deleted 7(r) Ornamental Iron and Bronze.

June 26, 1952 Revision

SECTION 2. CLASSIFICATION

Class A redefined as "Structural Steel."

Deleted the following sections:

SECTION 8. DELAYS IN PROSECUTION OF WORK

SECTION 9. EXTRA WORK

SECTION 10. PROPOSALS AND CONTRACTS

Deleted "Standard Documents."

February 20, 1963 Revision

SECTION 2. DEFINITION OF STRUCTURAL STEEL

Field Connected Material. The requirement to furnish an additional 5% of the bolts to cover waste, when erection is not performed by the fabricator, was dropped. Wording changed on other items not to be furnished.

SECTION 6. INSPECTION AND DELIVERY

(b) Shop Painting. Disclaimer added for deterioration of shop prime coat.

SECTION 7. ERECTION

(h) Tolerances. Originally titled Tolerances, this section was extensively revised and expanded. Reference to ASTM A6 tolerances was added. Limitations added for displacement of building columns in addition to the 1:50 error.

Sept 14, 1966 Revision

Changes were made in the following:

SECTION 7. ERECTION

(i) Correction of Errors when Material is not Erected by the Fabricator

July 1, 1970 Revision

Changes were made in the following:

SECTION 1. GENERAL

(b) Plans and Specifications for Bidding

SECTION 2. DEFINITION OF STRUCTURAL STEEL

SECTION 3. CALCULATION OF WEIGHTS

SECTION 4. DRAWINGS AND SPECIFICATIONS

(a) Untitled

SECTION 6. INSPECTION AND DELIVERY

(b) Inspection

(c) Shop Painting

SECTION 7. ERECTION

(e) Supporting Bases, Weldments, Castings and Bearing Plates

(g) Working Space

(h) Tolerances

(i) Temporary Bracing

(j) Correction of Errors

(k) Field Assembling

(l) Cuts and Alterations

(m) Temporary Floors for Buildings

(n) Field Painting

(o) Final Cleaning Up

October 1, 1972 Revision

Changes were made in the following:

SECTION 2. DEFINITION OF STRUCTURAL STEEL

SECTION 3. CALCULATION OF WEIGHTS

(b) Untitled

SECTION 4. DRAWINGS AND SPECIFICATIONS

(d) Untitled

SECTION 6. INSPECTION AND DELIVERY

(a) Test of Materials

(b) Inspection

(d) Delivery of Materials

(e) Marking and Shipping of Materials

7. ERECTION

(h) Tolerances

Also, a commentary to 7(h) was added.

September 1, 1976 Complete Revision

This was a complete revision incorporating a new format and many new or revised provisions. It was organized into ten sections as follows:

SECTION 1. GENERAL PROVISIONS

SECTION 2. CLASSIFICATION OF MATERIALS

SECTION 3. PLANS AND SPECIFICATIONS

SECTION 4. SHOP AND ERECTION DRAWINGS

SECTION 5. MATERIALS

SECTION 6. FABRICATION AND DELIVERY

SECTION 7. ERECTION

SECTION 8. QUALITY ASSURANCE

SECTION 9. CONTRACTS

SECTION 10. ARCHITECTURALLY EXPOSED STRUCTURAL STEEL

A complete Commentary was also provided.

September 1, 1986 Revision

Organized into the same ten sections as the previous edition, but Section 10 was re-titled, Quality Control. A expanded preface was added and numerous revisions were made including the following:

SECTION 6. FABRICATION AND DELIVERY

6.3.3 Added requirement for high-strength bolts to be installed in accordance with the RCSC Specification.

SECTION 7. ERECTION

7.7.3(d) Required the fabricator to furnish back-up bars and run-off tabs when erection is by others.

7.7.5 Required field-installed shear connectors to be supplied by the applicator.

7.7.6 Required metal deck support angles to be furnished by the deck supplier.

7.11.3.2 Members Other Than Columns. Combined two related paragraphs on tolerances and expanded the provisions.

SECTION 8. QUALITY CONTROL

8.1 General. Expanded requirements, referenced the AISC Quality Certification Program, and divided into three subsections.

SECTION 9. CONTRACTS

9.1.4 Added stipulation for unit price contracts.

June 10, 1992 Revision

Organized into the same ten sections as the previous edition. Some new subsections were added and numerous revisions were made including the following:

SECTION 1. GENERAL PROVISIONS

1.5.2 Added verbiage to indicate that the fabricator is responsible for the structural design if a design/fabricate contract is entered into. Repeated clause from 1.5.1, "The fabricator is not responsible for the safety of erection if the structure is erected by others."

SECTION 3. PLANS AND SPECIFICATIONS

3.1.5 New subsection regarding non-self-supporting frames.

3.1.6 New subsection requiring camber to be shown when required.

3.1.7 New subsection regarding specification of painting requirements.

SECTION 4. SHOP AND ERECTION DRAWINGS

4.2.1 Expanded verbiage on approval of shop drawings.

SECTION 5. MATERIALS

5.1 Mill Materials. Added clauses to indicate that when the fabricator receives "released for construction" plans and specifications, the fabricator may immediately order materials.

SECTION 7. ERECTION

7.2 Site Conditions. Expanded discussion of responsibilities of parties.

7.4 Building Lines and Benchmarks. Added requirement for owner to establish offset building lines and reference elevations at each level for the use of the erector.

7.11.3.3(c) Added tolerance for location of the ends of abutting adjustable items.

SECTION 8. QUALITY ASSURANCE

8.5.5 Requires any reports by owners inspectors to be given to the fabricator and erector immediately so that any corrective work can be performed timely.

8.5.6 New subsection places restrictions on the owners inspectors approval of changes.

March 7, 2000 Adopted New Code

Overview. This edition of the *Code* was developed by a broad group of representatives from the entire steel design and construction team including structural engineers, architects, a general contractor, fabricators, a steel detailer, steel erectors and an attorney. From adding provisions for fast-track project delivery to clarifying the language relating to connection design responsibility, the new *Code* offers clear-cut document language for every steel project. The scope statement in Section 1.1 of the *Code* indicates "In the absence of specific instructions to the contrary in the contract documents, the trade practices that are defined in this *Code* shall govern the fabrication and erection of structural steel." Thus, the *Code* is the standard of custom and usage for structural steel fabrication and erection. Alternative and supplementary requirements may exist in the contract documents and would control; however, the corresponding commentary clarifies that there may be some cost associated with such requirements. The presentation is in dual-units format, with both U.S. customary units and metric units provided.

Commentary information, when applicable, has been placed in shaded boxes immediately following its corresponding section of the Code. The Commentary often provides guidance and insight into the issues that surround a particular Code provision or requirement. This additional information can often be invaluable when applying and interpreting the Code.

Use of the term "Owner" throughout the *Code* generally has been eliminated, where appropriate. As it used to be, the term "Owner" most often really meant the owner's representative, but it was just as often not clear whether this was the designer or the constructor. To eliminate this confusion in the new *Code*, one or both of the terms "Owner's Designated Representative for Design" and "Owner's Designated Representative for Construction" has been used. These terms and the term "Owner", which is still used when appropriate, remain general enough to allow for the normal range of contractual arrangements, but are specific enough so that the intent is clear.

The major changes are as follows:

Section 1.7 Requirements for existing structures have been added in Section 1.7 to cover issues in existing structures, such as demolition and shoring, protection against damage, surveying or field dimensioning, and hazardous materials. Although each of these considerations is not applicable to every project, their inclusion serves to highlight the associated issues. The default condition in the *Code* states that someone other than the fabricator and erector is responsible for these considerations.

Section 2.1 The classifications of materials in Section 2 have been editorially revised and expanded. Section 2.1 lists items that are considered to be structural steel and, therefore covered by the *Code*. Section 2.2 lists items that are not. For the most part, the items in Section 2.1 are produced in the fabrication shop or are directly related to those items. Other items and the items in Section 2.2 are not.

Section 3.3 Provisions for the resolution of discrepancies have been added. Essentially, the provisions require that discrepancies be reported when discovered, but do not obligate the fabricator to find discrepancies. For the case where a discrepancy is discovered after fabrication and/ or erection, an order of precedence of the various contract documents is maintained as well, although the order of precedence has been changed for simplicity and to better reflect current practices. In the new *Code*, the design drawings govern over the specifications for both buildings and bridges.

Section 3.5 The provisions for revisions have been clarified: "... all revisions, including those that are communicated through the annotation and/or erection drawings ..., shall be clearly and individually indicated in the contract documents." It is also required that the contract documents be dated and identified by revision number (and the same drawing number throughout the project). Also see Sections 3.5, 3.6, 4.4.2, and 9.4.1.

Section 3.6 Provisions for fast-track project delivery have been added. Fast-track is recognized as a great option among project delivery systems that has the potential to make steel the best (if not the only) choice for construction. On the other hand, it also highlights the risk the owner must accept for additional design and construction costs when the structural design, fabrication and/or erection is completed before other aspects, such as the architectural program and mechanical systems, have been completed.

Section 4 The responsibilities of the various entities involved in the shop and erection drawing approval process have been simplified and clarified.

Section 4.3 Issues regarding the use of design drawings by the fabricator and/or the erector are now covered. Permission is required for such use, since drawings represent intellectual property. Other more specific requirements apply as indicated.

Section 6.4.2 The permissible variation from theoretical curvature for a curved member is now covered. To do so, the ASTM A6/A6M tolerances for out-of-straightness for a straight member are applied relative to the theoretical line of curvature of the curved piece of equivalent length.

Section 6.4.5 Provisions have been added to cover permissible variations in camber for fabricated trusses. At specified points of camber in fabricated trusses, the tolerance on the camber ordinate is given as 1/800 times the distance from that point to the nearest point of support.

Section 6.5 This section has been editorially restructured and substantively modified to recognize that the majority of steel in building structures need not be primed or painted. Otherwise, the requirements are similar to those in past editions of the Code.

Section 7.7 Coverage of bearing devices has been revised. Installation of bearing devices is now covered in Section 7.6 and grouting is covered in Section 7.7. Mostly, this change emphasizes the importance of the timing of the grouting operation, which is now more specifically covered in the Code.

Section 7.10 Use of the terms self-supporting and non-self-supporting (in the old Section 7.9) has been eliminated and replaced with provisions for temporary support. Also, the loads that require consideration during erection have been revised.

Section 7.12 The intent of the provisions that address the accumulation of mill tolerances and fabrication tolerances and their relationship to the erection tolerances has been clarified. The accumulation of mill and fabrication tolerances is allowed, but subject to the limitation that the erection tolerances are not exceeded.

Section 8 Quality assurance provisions have been revised to recognize both the AISC Quality Certification program for fabricators and the AISC Erector Certification program.

Section 10.2.5 Architecturally Exposed Structural Steel (AESS) requirements for welds have been clarified. In the absence of other criteria, the visual criteria in AWS D1.1 apply.

Section 10.2.8 AESS requirements for HSS weld seams have been added. It is required that weld seams be oriented away from view or as directed in the contract documents.

INDEX

Allowable stresses:

- Bolts, 15, 18, 19
- Rivets, 14
- structural steel, 12

AISC:

- Code of Standard Practice, 311 to 316
- Manual, 301 to 303
- Seismic Provisions, 215 to 221
- Specification, 12, 259 to 300

Design strength:

- Bolts, 15, 19
- Rivets, 14
- structural steel, 215 - 221
- welds, 20, 309

Enhancement of Structures:

- columns 224
- connections, 225
- floors, 223
- frames, braced, concentric, 225
- frames, braced, eccentric, 225
- frames, moment, fully restrained, 224
- frames, moment, partially restrained, 225
- gravity systems, 223
- lateral systems, 224

Existing members:

- holes in, drilling of, 231
- thermal cutting of, 230
- welding to, 229

Evaluation of structures:

- methods for, 215 to 221
- reasons for, 215
- specification for, 216 to 220

References:

- case studies, 240 to 250
- general, 237 to 240
- seismic, 250 to 258
- summaries of, 237 to 258

Rehabilitation (*See* Enhancement of Structures)

Retrofit (*See* Enhancement of Structures)

Seismic:

- code, 215
- damage, 215
- rehab, 227 to 231
- references, 215, 216, 250 to 258

Section properties:

- steel sections, 1971-2000, 22
- steel sections, 1953-1970, 27
- steel sections, 1887-1952, 35
- wrought iron, 1873-1900, 196

Specifications:

- ASTM, 4 to 11
- bolts, 3, 15 to 19
- bolted joints, 15 to 19, 305 to 308
- historical review of, 259 to 310
- hollow structural sections, 1
- pipe, steel, 1, 13
- rivets, 2, 14
- structural steel, 1 to 12
- tubes (*see* hollow structural sections)
- welding, 309 to 310

(*see also*: AISC)