



DESIGNING WITH STRUCTURAL

# STEEL

A GUIDE FOR ARCHITECTS

SECOND EDITION



AMERICAN INSTITUTE OF STEEL CONSTRUCTION

One East Wacker Drive, Suite 3100

Chicago, Illinois 60601-2000

Tel. 312.670.2400

Fax 312.670.5403

[www.aisc.org](http://www.aisc.org)



Copyright © 2002

by

American Institute of Steel Construction, Inc.

ISBN 1-56424-052-5

*All rights reserved. This book or any part thereof  
must not be reproduced in any form without the  
written permission of the publisher.*

The information presented in this publication has been prepared in accordance with recognized engineering principles and is for general information only. While it is believed to be accurate, this information should not be used or relied upon for any specific application without competent professional examination and verification of its accuracy, suitability, and applicability by a licensed professional engineer, designer, or architect. The publication of the material contained herein is not intended as a representation or warranty on the part of the American Institute of Steel Construction or of any other person named herein, that this information is suitable for any general or particular use or of freedom from infringement of any patent or patents. Anyone making use of this information assumes all liability arising from such use.

Caution must be exercised when relying upon other specifications and codes developed by other bodies and incorporated by reference herein since such material may be modified or amended from time to time subsequent to the printing of this edition. The Institute bears no responsibility for such material other than to refer to it and incorporate it by reference at the time of the initial publication of this edition.

Printed in the United States of America

# CONTENTS IN BRIEF



## IDEAS

Structural Steel Today  
Structural Steel Framing Solutions for Multi-Story Residential Buildings  
Building Tomorrow's Parking Structures Today  
Project Profiles  
    Cologne/Bonn Airport  
    Fashion Square Retail Center  
    Jefferson at Lenox Park  
    John F. Kennedy International Airport  
    Mystic Marriott Hotel & Spa  
    Newark International Airport  
    Nortel Networks  
    Portland International Airport  
    Winthrop University Hospital



## SYSTEMS

### PART I

Basic Structural Engineering  
    Understanding Load Flow  
    Types of Basic Lateral Systems  
    Beam Web Penetrations  
    Thermal Movement of Structural Steel  
    Floor Vibration

### PART II

Protecting Structural Steel  
    Guide to Coatings Technology  
        Basics of Protective Coatings  
        Composition of Coatings  
        Types of Coatings  
        Painting Guides  
        Special Purpose Coating Systems  
        Paint Systems  
        Surface Preparation  
        Other Substrates  
        Use of Protective Coatings  
        Evaluation of Existing Coating for Overcoating  
        Coating Test Methods and Procedures  
        Surface Preparation for Overcoating Systems  
        Quality Assurance  
        Evaluation of Performance Requirements for Coating Systems  
        Protecting Substrates from Corrosion  
        Economics  
        Inspection  
        Coating References  
    Sample Painting Guide Specifications

Fire Protection  
General Factors  
Fire Protection Materials  
Underwriters Laboratories (UL) Assemblies  
Restrained and Unrestrained Construction  
Architecturally Exposed Steel  
Rational Fire Design Based on Fire Engineering

### **PART III**

Determining Member Sizes for Detailing  
Determining Girder and Beam Sizes for Floors & Roofs  
Determining Interior Column Sizes

### **PART IV**

Miscellaneous  
Bending and Shaping of Structural Members  
Welding Symbols and Appearance of Exposed Welded Connections  
Latest Code Provisions for Architecturally Exposed Structural Steel



## **MATERIALS**

W-, S-, C-, MC-, HP-, M-Shapes and Angles  
Structural Tees (WT-, MT- and ST-Shapes)  
Hollow Structural Sections (HSS) and Pipe  
Plates and Bars



## **DETAILS**

General Considerations  
Detailing Considerations for Masonry  
Detailing Considerations for Precast Concrete Panels  
Detailing Considerations for Limestone Panels  
Detailing Considerations for Thin Stone Veneer Panels  
Detailing Considerations for Window Wall Enclosure Systems  
Detailing Considerations for Floor/Ceiling Sandwich  
Design Considerations for Diagonal Bracing Details  
Additional References



## **APPENDIX**

Common Questions Answered  
Definitions  
Mill Production and Tolerances  
General Fabrication  
Fabrication and Erection Tolerances  
Painting and Surface Preparation  
Fire Protection  
References  
*Code of Standard Practice for Steel Buildings and Bridges, March 7, 2000*  
Construction Industry Organizations

## **INDEX**

## PREFACE

The purpose of this Guide is to provide architects with the tools needed to feel more comfortable and confident working with structural steel in building projects. With a greater understanding of the characteristics and inherent benefits of structural steel, architects will be prepared to better utilize steel as a framing material. Some of the strengths structural steel offers in building design is high resiliency and performance under harsh and difficult conditions, i.e., earthquakes and hurricanes. Steel offers the ability to span great distances with slenderness and grace. Steel can be shaped to achieve curved forms and goes up quickly to meet tough construction schedules in almost any weather condition. Steel can be easily modified in the future to satisfy changing requirements. And with virtually all structural steel produced in the United States today made from recycled cars and other steel products, steel offers environmental sustainability for the future.

This Guide was created in response to research gathered by the American Institute of Steel Construction's (AISC) regional engineering staff through focus group meetings with owners, engineers, architects, construction managers and contractors throughout the United States. The purpose of this research was to determine how steel-framed building projects could be completed more economically and in less time, while still maintaining high levels of quality. To find the regional engineer in your area, visit the AISC website at [www.aisc.org](http://www.aisc.org).

One of the findings of these focus groups was that architects were eager for more knowledge of how to incorporate structural steel into building design. In response to this need, AISC set out to create a guidebook for architects that would provide an understanding of the structural systems, material properties and design details for structural steel. To that end industry experts from all fields—architects, engineers, fabricators and coating specialists—were assembled to provide the most up-to-date and accurate information on designing in structural steel.

*Designing with Structural Steel: A Guide for Architects*, is presented in five sections. The *Ideas* Section contains the booklet, *Structural Steel Today*, showcasing buildings that incorporate structural steel's unique features to create truly inspiring architectural designs. Also included in this section is a series of project profiles.

The *Systems* Section explains basic concepts in structural steel design. It is intended to help the architect communicate more easily with the structural engineer. This section also presents an in-depth discussion of the types of coating systems available for structural steel for instances where coating protection is needed. The section also provides information of welding and sizing of beams and columns for purposes of architectural detailing.

The *Details* Section provides plan details and commentary on the use of structural steel in combination with other building materials like precast concrete panels, masonry, thin stone veneer panels and limestone. The *Materials* Section contains dimensional properties (in both English and metric units), of wide-flange shapes, hollow structural sections and other sections. The *Materials* Section also provides architects with additional information needed for architectural detailing.

The *Appendix* is divided into three parts. The *AISC Code of Standard Practice* covers standard communications through plans, specifications, shop drawings and erection drawings; material, fabrication, and erection tolerances and quality requirements; contracts; and requirements for architecturally exposed steel. Also provided are answers to common questions about codes, specifications and other standards applicable to structural steel. The final part of this section is an information-source-list of names, addresses, phone numbers and website addresses for industry organizations that can be of service to the building team.

This Guide is meant to be a teaching tool as well as a desk reference on structural steel. It is meant to be a "living document." To this end it has been published in a three-ring binder to accommodate additions and updated information to be published in the future.

The editors would like to thank all of those who contributed their time, effort and knowledge in producing a publication that can be used on a daily basis. We welcome your comments and suggestions for future additions to the guidebook.

Alford Johnson  
Chicago 2002



## **CONTRIBUTORS**

### **IDEAS**

Alford Johnson, Vice President Marketing, American Institute of Steel Construction, Inc.

### **SYSTEMS**

Del Boring, P.E., Senior Director, American Iron & Steel Institute

Mark Zahn, S.E., Structural Engineer

Karl Angeloff, P.E., Manager Marketing Development, Bayer Corporation

Alford Johnson, Vice President Marketing, American Institute of Steel Construction, Inc.

### **DETAILING**

David E. Eckmann, AIA, S.E., Structural Department Head, OWP&P Architects, Inc.

Geoffrey Walters, AIA, Architect, OWP&P Architects, Inc.

### **APPENDIX**

Charles J. Carter, S.E., P.E., Chief Structural Engineer, American Institute of Steel Construction, Inc.





DESIGNING WITH STRUCTURAL

# STEEL

A GUIDE FOR ARCHITECTS

SECOND EDITION





## CONTENTS OF IDEAS SECTION

### INTRODUCTION

Structural Steel Today

Structural Steel Framing Solutions for Multi-Story Residential Buildings

Building Tomorrow's Parking Structures Today

#### Project Profiles

Cologne/Bonn Airport

Fashion Square Retail Center

Jefferson at Lenox Park

John F. Kennedy International Airport

Mystic Marriott Hotel & Spa

Newark International Airport

Nortel Networks

Portland International Airport

Winthrop University Hospital



## INTRODUCTION

The *Ideas* Section is a collection of publications that colorfully illustrate the many possibilities with structural steel. The first document, *Structural Steel Today*, presents a series of projects that take advantage of the inherent benefits of structural steel as a framing material. Color photos and illustrated details convey steel's ability to be shaped into a desired form, cover long spans, allow for modification of an existing structure, erect a structure under tight time constraints and be recycled.

Following *Structural Steel Today* are a series of brochures and project profiles showing structural steel used in hotels, condominiums, apartments, school dormitories, senior housing and parking garages. There will be additional idea-provoking literature in the future that should find a place in this *Ideas* Section.



## CONTENTS OF SYSTEMS SECTION

INTRODUCTION .....	7
--------------------	---

### PART I

#### BASIC STRUCTURAL ENGINEERING

UNDERSTANDING LOAD FLOW .....	9
Gravity Loads .....	9
Horizontal Loads .....	10
Seismic .....	11
TYPES OF BASIC LATERAL SYSTEMS .....	11
Braced Frames — General .....	12
Braced Frames — Cross Bracing .....	12
Braced Frames — Chevron Bracing .....	13
Eccentrically Braced Frames .....	13
Rigid Frames .....	14
Shear Walls .....	15
BEAM WEB PENETRATIONS .....	15
THERMAL MOVEMENT OF STRUCTURAL STEEL .....	17
FLOOR VIBRATION .....	20
Basic Vibration Terminology .....	20
Floor Vibration Principles .....	22
Summary .....	24

### PART II

#### PROTECTING STRUCTURAL STEEL

GUIDE TO COATINGS TECHNOLOGY .....	25
BASICS OF PROTECTIVE COATINGS .....	25
The Corrosion Process .....	25
Coatings in Corrosion Control .....	26
COMPOSITION OF COATINGS .....	26
Pigments .....	26
Non-Volatile Vehicles (Binders) .....	27
Volatile Vehicles (Solvents) .....	28
Additives .....	28



TYPES OF COATINGS. . . . .	29
Zinc-Rich Primers. . . . .	29
Epoxy . . . . .	29
Acrylics . . . . .	30
Polyurethane . . . . .	30
Alkyds. . . . .	30
PAINTING GUIDES . . . . .	30
SPECIAL PURPOSE COATING SYSTEMS . . . . .	31
Intumescent Paint. . . . .	31
Hot-Dip Galvanizing . . . . .	31
Galvanized Steel — Painted (Duplex System) . . . . .	32
PAINT SYSTEMS . . . . .	36
Government Standards . . . . .	36
Coating Systems . . . . .	36
Interior Structural Steel . . . . .	36
SURFACE PREPARATION . . . . .	39
Clean Surfaces and Performance . . . . .	39
Specifications . . . . .	39
OTHER SUBSTRATES . . . . .	41
USE OF PROTECTIVE COATINGS . . . . .	42
Shop Painting Bare Steel . . . . .	42
Requirements for Preparation of Bare Metal. . . . .	42
Preparation Methods and Specifications . . . . .	43
EVALUATION OF EXISTING COATING FOR OVERCOATING . . . . .	46
Overcoat Paint Process . . . . .	46
Coating Evaluation . . . . .	46
COATING TEST METHODS AND PROCEDURES. . . . .	47
Compatibility of Overcoating System. . . . .	48
SURFACE PREPARATION FOR OVERCOATING SYSTEMS. . . . .	48
Method A: High-Pressure Water Wash . . . . .	48
Method B: Hand and Power Tool Cleaning. . . . .	49
QUALITY ASSURANCE . . . . .	49
EVALUATION OF PERFORMANCE REQUIREMENTS FOR COATING SYSTEMS . . . . .	50
PROTECTING SUBSTRATES FROM CORROSION . . . . .	51



Corrosive Environments . . . . .	51
Corrosion Performance Testing . . . . .	52
Test Panels as Substitutes for Structures . . . . .	53
Weathering Environments . . . . .	53
Weathering Performance Testing . . . . .	53
Other Types of Performance Environments . . . . .	54
Specifying Paint to Meet Performance Needs . . . . .	54
ECONOMICS . . . . .	54
Cost of Materials . . . . .	54
Life Cycle Cost . . . . .	55
Transfer Rates . . . . .	55
Estimating Paint Requirements . . . . .	55
INSPECTION . . . . .	55
COATING REFERENCES . . . . .	56
SAMPLE PAINTING GUIDE SPECIFICATIONS	
FIRE PROTECTION . . . . .	57
GENERAL FACTORS . . . . .	57
Building Codes . . . . .	57
Combustibility of the Structural Materials . . . . .	58
Fire Resistance of the Structure . . . . .	58
Effect of Temperature on Steel . . . . .	60
Temperatures of Fire Exposed Structural Steel Elements . . . . .	60
FIRE PROTECTION MATERIALS . . . . .	62
Gypsum . . . . .	62
Spray-applied Fire Resistive Material . . . . .	63
Suspended Ceiling Systems . . . . .	64
Concrete and Masonry . . . . .	64
Intumescent Coatings . . . . .	65
UNDERWRITERS LABORATORIES (UL) ASSEMBLIES . . . . .	65
RESTRAINED AND UNRESTRAINED CONSTRUCTION . . . . .	65
Partial Extract of the Appendix to ASTM E119-00a: Standard Test Methods for Fire Tests of Building Construction and Materials . . . . .	70
ARCHITECTURALLY EXPOSED STEEL . . . . .	72
Exterior Applications . . . . .	72
Interior Applications . . . . .	73
RATIONAL FIRE DESIGN BASED ON FIRE ENGINEERING . . . . .	74



## PART III

### DETERMINING MEMBER SIZES FOR DETAILING

DETERMINING GIRDER AND BEAM SIZES FOR FLOORS & ROOFS . . . . .	77
Design Parameters and Limitations . . . . .	77
DETERMINING INTERIOR COLUMN SIZES . . . . .	89
Design Parameters and Limitations . . . . .	89

## PART IV

### MISCELLANEOUS

BENDING AND SHAPING OF STRUCTURAL MEMBERS . . . . .	97
WELDING SYMBOLS AND APPEARANCE OF EXPOSED WELDED CONNECTIONS . . . . .	99
LATEST CODE PROVISIONS FOR ARCHITECTURALLY EXPOSED STRUCTURAL STEEL . . . . .	101

## LIST OF FIGURES

Figure 1. Forces experienced by structures . . . . .	9
Figure 2. Gravity and wind loads . . . . .	10
Figure 3. Loads on columns and beams . . . . .	10
Figure 4. Horizontal diaphragm/lateral load resisting interface . . . . .	11
Figure 5. Typical floor plan with cross bracing . . . . .	12
Figure 6. Cross-braced building elevation . . . . .	12
Figure 7. Typical beam to column brace connections . . . . .	13
Figure 8. Typical floor plan with Chevron bracing . . . . .	14
Figure 9. Elevation with Chevron bracing . . . . .	14
Figure 10. Eccentric brace with typical brace to beam connection . . . . .	14
Figure 11. Typical floor plan with rigid frames . . . . .	15
Figure 12. Rigid frame building elevation . . . . .	15
Figure 13. Typical rigid (moment) connection . . . . .	15
Figure 14. Concentric and eccentric web penetrations . . . . .	16
Figure 15. Diagram of building expansion example . . . . .	18
Figure 16. Double-column movement connection . . . . .	19
Figure 17. Seated slide-bearing connection . . . . .	19
Figure 18. Types of dynamic loading . . . . .	21
Figure 19. Decaying vibration with viscous damping . . . . .	21
Figure 20. Response to sinusoidal force . . . . .	21





Figure 21. Typical beam and floor system mode shapes . . . . .	22
Figure 22. Frequency spectrum . . . . .	22
Figure 23. Recommended peak acceleration for human comfort for vibrations due to human activities (International Standards Organization [ISO], 2631-2: 1989) . . . . .	23
Figure 24. High potential corrosion areas of high-rise buildings . . . . .	33
Figure 25. High-rise building design checklist . . . . .	35
Figure 26. NIST graph illustrating the relationship of fire severity to the average weight of combustibles in a building . . . . .	58
Figure 27. Graph from ASTM E119 test showing relationship of time to fire resistance temperature requirements. . . . .	58
Figure 28. Time/temperature curves for various fire exposures . . . . .	60
Figure 29. Determination of heated perimeter of columns and beams. <i>American Iron and Steel Institute; Designing Fire Protection for Steel Columns, Designing Fire Protection for Steel Beams.</i> . . . . .	61
Figure 30. Variation in fire resistance of structural steel columns with weight to heated perimeter ratios and various gypsum wallboards. Illustration courtesy of the American Iron and Steel Institute; <i>Designing Fire Protection for Steel Columns.</i> . . . . .	62
Figure 31. Some methods for applying gypsum as fire protection for structural steel: (a) open-web joist with plaster ceiling; (b) beam enclosed in a plaster cage; (c) beam boxed with wallboard. Illustration courtesy of the Gypsum Association, <i>Fire Resistance Design Manual</i> . . . . .	62
Figure 32. Mineral fiber spray applied to beam and girder floor system with steel floor deck supporting a concrete slab. Illustration courtesy of the American Iron and Steel Institute; <i>Designing Fire Protection for Steel Beams.</i> . . . . .	63
Figure 33. Steel floor system fire protected on the underside by a suspended ceiling. Illustration courtesy of the American Iron and Steel Institute; <i>Designing Fire Protection for Steel Columns.</i> . . . . .	64
Figure 34. Fire protected exterior steel column with exposed metal column covers. Illustration courtesy of the American Iron and Steel Institute, <i>Fire Protection Through Modern Building Codes</i> . . . . .	72
Figure 35. Tubular steel columns filled with water for fire resistance with temperature variation during exposure to fire. Illustration courtesy of the American Iron and Steel Institute, <i>Fire Protection Through Modern Building Codes.</i> . . . . .	72
Figure 36. Schematic representation of a liquid-filled column fire protection system. Illustration courtesy of U.S. Steel, <i>Influence of Fire on Exposed Exterior Steel.</i> . . . . .	73
Figure 37. Fire-resistive flame shielding on spandrel girder. Illustration courtesy of U.S. Steel, <i>Influence of Fire on Exposed Exterior Steel</i> . . . . .	73



Figure 38. Flame patterns and temperatures during two fire tests on the load-carrying steel plate girder. Illustration courtesy of U.S. Steel, <i>Influence of Fire on Exposed Exterior Steel</i> . . . . .	73
Figure 39. Concrete-based insulating material. . . . .	74
Figure 40. Typical connections in a continuous shell. . . . .	74
Figure 41. Bending steel shapes with pinch rollers . . . . .	97
Figure 42. Made-up segmented curves . . . . .	99
Figure 43. Fillet welds . . . . .	100
Figure 44. Groove welds . . . . .	100

## LIST OF TABLES

Table 1. Paint Systems . . . . .	37
Table 2a. Paint Systems in Table 1 Applicable to Maintenance Painting Involving Spot Repairs and Overcoating. . . . .	38
Table 2b. Paint Systems in Table 1 Applicable to New Construction or Maintenance Painting Where Existing Paints are Completely Removed . . . . .	38
Table 3. Coating Incompatibility . . . . .	49
Table 4. FHWA Test Program: Coating Systems for Minimally Prepared Surfaces . . . . .	50
Table 5. Typical Occupancy Fire Loads and Fire Severity . . . . .	59
Table 6. Roof-Ceiling Assemblies . . . . .	66
Table 7. Floor-Ceiling Assemblies. . . . .	67
Table 8. Beam-Only Designs for Roofs . . . . .	68
Table 9. Beam-Only Designs for Floors. . . . .	68
Table 10. Column Assemblies . . . . .	69
Table 11. Bent and Rolled Standard Mill Shapes . . . . .	98
Table 12. Typical Welding Symbols . . . . .	102



## INTRODUCTION

The Systems Section offers a primer on structural engineering and steel systems design written especially for the architect. The purpose of this section is to help architects better understand and communicate with professionals who are experts in engineering and fabricating structural steel. There are many intricate systems acting independently and contingent upon one another in a building. Architects are faced with the unique predicament of designing an entire structure filled with systems, often without having in-depth knowledge of any one system. They must rely on the technical competence of engineering specialists to design and perfect individual systems, and then combine them to work in harmony throughout the entire structure.

This section is presented in four parts. Part I covers basic structural engineering concepts such as load flow, thermal movement, lateral load resisting systems, and accommodation of HVAC systems. It concludes with an explanation of design considerations for floor vibration. Part II discusses painting, coating and fire protection technologies. Part III presents the information needed by architects to determine girder and beam sizes for floors and roofs for detailing purposes. Lastly, Part IV provides an explanation of the process of bending and shaping structural members to create aesthetic and elegant curved lines within a building without adding weight. The section concludes with provisions needed for working with steel that is exposed to view, commonly referred to as architecturally exposed structural steel or AESS.





## PART I

# BASIC STRUCTURAL ENGINEERING

## UNDERSTANDING LOAD FLOW

All structures are subjected to forces that are imposed by gravity, wind and seismic events (see Figure 1). The combination and anticipated severity of these forces will determine the maximum design force the member can sustain. The structural engineer will then select a member that meets all of the strength as well as serviceability issues such as deflection and/or vibration criteria for any specific project. The following is a brief discussion on each of the types of loads and how these loads are transferred to the other structural components.

### Gravity Loads

Gravity loads include all forces that are acting in the vertical plane (see Figure 2). These types of forces are commonly broken down into dead loads and live loads in a uniform pounds per square foot loading nomenclature. Dead loads account for the anticipated weight of objects that are expected to remain in place permanently. Dead loads include roofing materials, mechanical equipment, ceilings, floor finishes, metal decking, floor slabs, structural materials, cladding, facades and parapets. Live loads are those loads that are anticipated to be mobile or transient in nature. Live loads include occupancy loading, office equipment and furnishings.

The support of gravity loads starts with beams and purlins. Purlins generally refer to the roof while beams generally refer to floor members. Beams and purlins support no other structural members directly. That is to say, these elements carry vertical loads that are uniform over an area and transfer the uniform loads into end reactions carried by girders.

Girders generally support other members, typically beams and/or purlins, and span column to column or are supported by other primary structural members. Girders may support a series of beams or purlins or they may support other girders. Forces imposed on girders from beams, purlins, or other girders are most often transferred to the structural columns. The structural column carries the vertical loads from all floors and roof areas above to the foundation elements.

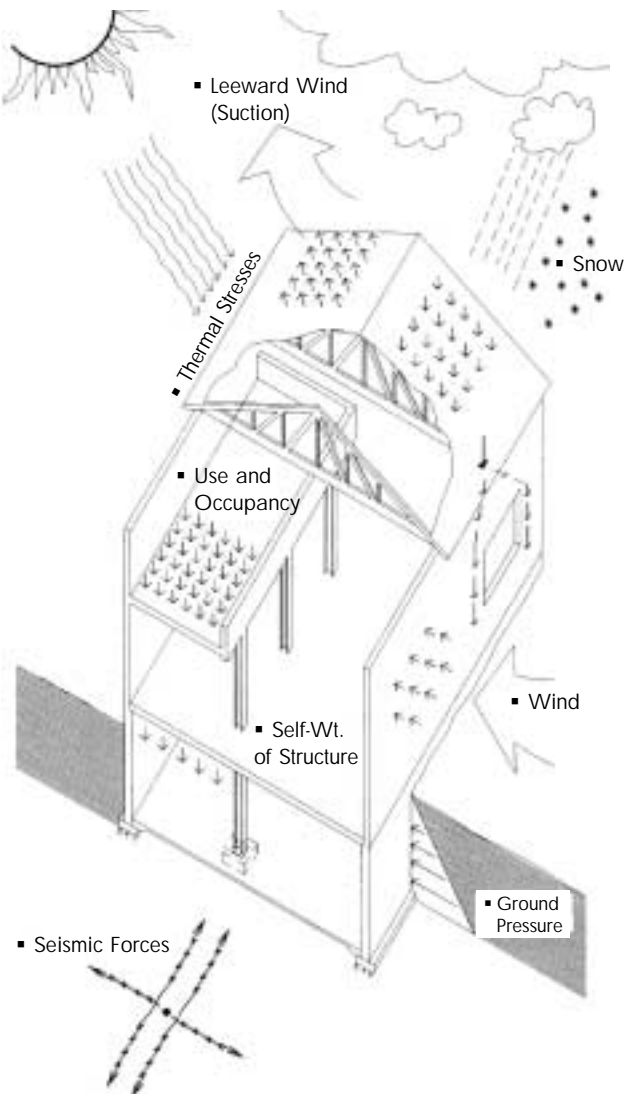


Figure 1. Forces experienced by structures



## Horizontal Loads

Forces created by wind or seismic activity are considered to act in the horizontal plane. While seismic activity is capable of including vertical forces, this discussion will be based only on horizontal forces. The majority of this section will address wind forces and how they are transferred to the primary structural systems of the building (see Figure 3).

Wind pressures act on the building's vertical surfaces and create varying forces across the surface of the façade. The exterior façade elements, as well as the primary lateral load resisting system, are subjected to the calculated wind pressures stipulated by code requirements. This variation accounts for façade elements being exposed to isolated concentrations of wind pressures that may be redistributed throughout the structural system. Design wind pressures can be calculated using a documented and statistical history of wind speeds and pressure in conjunction with the building type and shape. Calculated wind pressures act as a pushing force on the windward side of a building. On the leeward (trailing) side of the building, the wind pressures act as a pulling or suction force. As a result, the exterior façade of the entire building must be capable of resisting both inward and outward pressures.

Roof structures made up of very light material may be subjected to net upward or suction pressures from wind as well. Roofs typically constructed of metal decking, thin insulation and a membrane roof material without ballast have the potential to encounter net upward forces. Roof shape may also determine the net uplift pressures caused by wind. Curved roofs will actually exhibit a combination of downward pressures on the top portion of the curve and upward pressure on the lower portion of the curve. This distribution of downward and upward pressures caused by the curve is similar to the principles of air pressure and lift acting on an airplane wing.

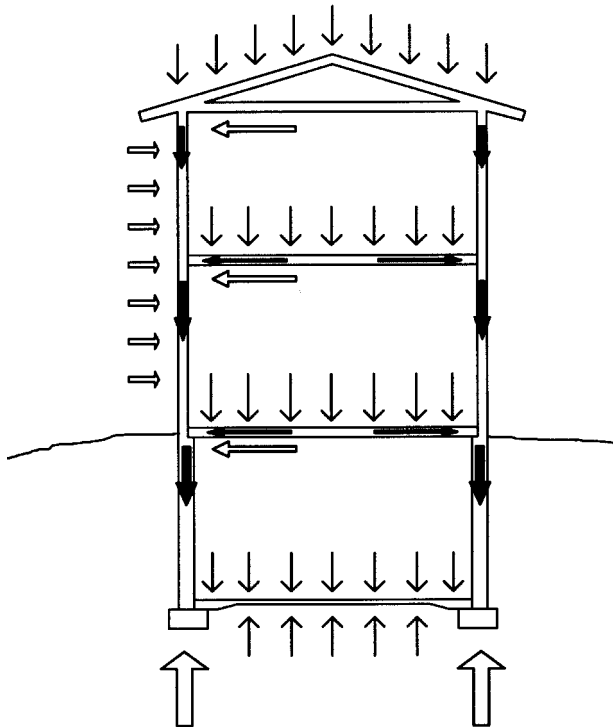


Figure 2. Gravity and wind loads

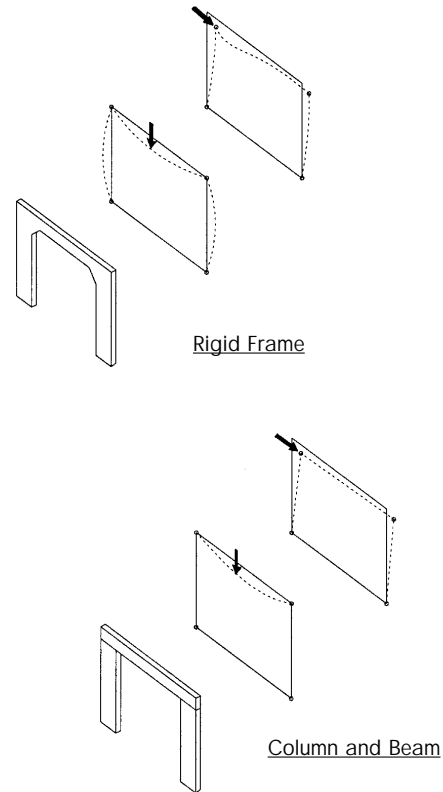


Figure 3. Loads on columns and beams



As the wind pressures are applied to the exterior of the building, the façade (actually a structural element to some degree), transfers the horizontal pressures to the adjacent floor or roof. As these pressures are transferred, the floor and roof systems must have a means to distribute the forces to the lateral load resisting systems. Floors and roofs that are generally solid or without large openings or discontinuities may behave as a diaphragm. A diaphragm is a structural element that acts as a single plane with the connecting beams and columns. When experiencing a force, this single plane causes the beams and columns to displace horizontally the same amount as the diaphragm. This can be exemplified by a sheet of paper or cardboard that is supported by a series of columns. Should the paper, a flexible diaphragm, be pushed horizontally, all points in contact with the paper will move laterally by the same amount. The metal roof decking on most projects will behave as a flexible diaphragm. Substituting a piece of cardboard for paper in our example, the paper will behave more like a rigid diaphragm. A typical floor decking and composite structural slab are examples of a rigid diaphragm.

Horizontal diaphragms are an efficient means to transfer the horizontal loads at each level of a building to the lateral load resisting systems (see Figure 4). Should large openings, such as atriums, skylights, raised floors or other discontinuities exist to interrupt the diaphragm, the lateral or horizontal loads may not flow easily to the lateral load resisting systems. As a result, the structural engineer will investigate the need for a horizontal truss system utilizing the floor beams and/or girders as chord members. Secondary web members will be added to complete the truss concept. This is particularly common in roof areas where there may be very long continuous skylights on a relatively narrow or long roof area.

## Seismic

Seismic activity induces horizontal forces, and at times, vertical loads. The discussions in this publication will focus on horizontal forces imposed during seismic activity. Forces created during a seismic event are directly related to weight or mass of the various levels on a specific building. During seismic activity horizontal diaphragms behave like wind load transfers with respect to the primary lateral load resisting systems. However, the induced forces are much more sensitive to the shape of the building and the positioning of the lateral load resisting systems. It is advantageous to consider a very regular building plan in areas of the country with significant seismic activity.

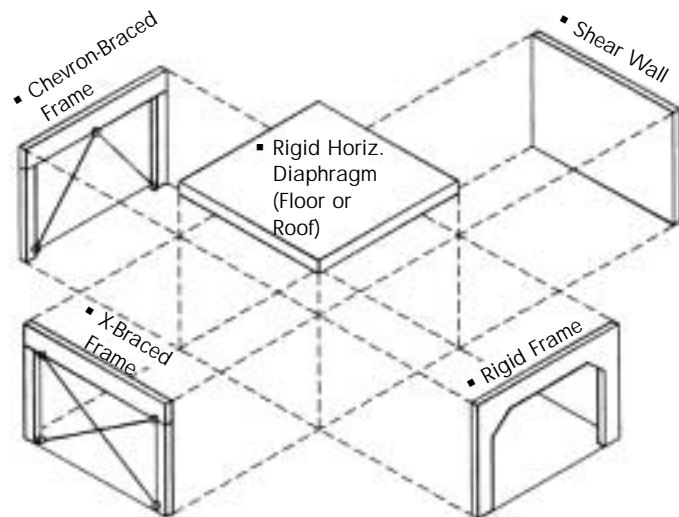


Figure 4. Horizontal diaphragm/lateral load resisting interface

## TYPES OF BASIC LATERAL SYSTEMS

During the initial planning stage of any project, consideration should be made for the type of lateral load resisting system(s) to be used in the building. Three basic types of lateral resisting systems are commonly used: braced frames, rigid frames, and shear walls. The structural engineer should be consulted early in the project to establish the type of system best suited for the specific building footprint, height and available locations. Careful consideration should be given to meet the lateral resistance requirements of the structure as well as the architectural needs of the building. In order to meet these needs the engineer may select one or more types of lateral systems. Each system has its own specific limitations and potential architectural implications.



## Braced Frames — General

Three types of braces used in braced frames typically seen in buildings today include the cross brace, Chevron (or inverted V) and eccentric brace. Cross bracing is often analyzed by the structural engineer as having tension-only members. Chevron bracing is used in a building that requires access through the bracing line. Eccentrically braced frames allow for doorways, arches, corridors and rooms and are commonly used in seismic regions to help dissipate the earthquake energy through the beam/girder between workpoints of the bracing/beam interface. Braced frames are generally more cost-effective when compared to rigid frame systems.

## Braced Frames — Cross Bracing

Perhaps the most common type of braced frame is the cross-braced frame. A typical representation of a cross-braced frame is shown in Figures 5 and 6. Figure 5 shows a typical floor framing plan with cross bracing denoted by the dashed-line drawn between the two center columns. The solid lines indicate the floor beams and girders. A typical multi-floor building elevation with cross-braced bays beginning at the foundation level is shown in Figure 6. While only one bay is indicated in Figure 6 as having cross bracing, it must be understood that many bays along a given column line may be necessary to resist the lateral loads imposed on a specific structure. One or more column lines having one or more bays of cross bracing may be necessary as well. It is important to establish early on in the development of any project the location of braced bays. These considerations are typical to all of the braced frames discussed in this publication.

Connections for this type of bracing are concentrated at the beam to column joints. Figure 7 illustrates a typical beam to column joint for a cross-braced frame. For taller buildings, usually over two or three stories, these connections could become large enough to minimize the available space directly adjacent to the column and below the beam. This restricted space may have an effect on the mechanical and plumbing distribution as well as any architectural soffit details. The structural engineer needs to be able to provide this type of information to the architect to avoid potentially costly field revisions during construction.

Bracing members are typically designed as tension only members. With this design approach only half of the members area active when the lateral loads area applied. The adjacent member within the same panel is considered to contribute no compressive strength. Utilizing tension only members makes very efficient use of the structural steel shape and will result in using the smallest members. Without full consideration of a specific bay size and amount and location of the bracing, a generalized range of sizes cannot be determined.

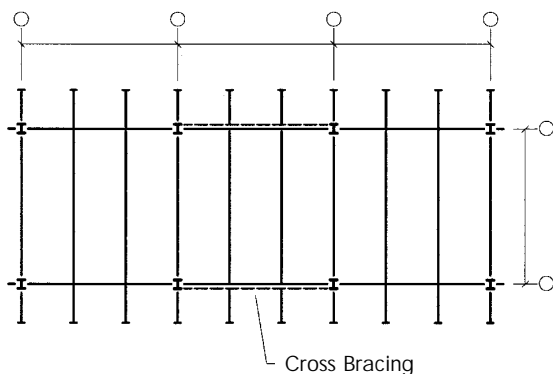


Figure 5. Typical floor plan with cross bracing

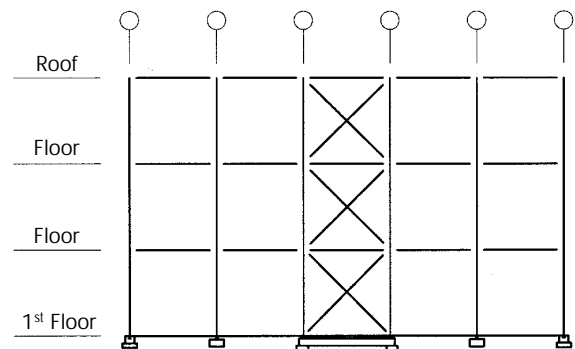


Figure 6. Cross-braced building elevation





Cross-braced frames are composed of single span, simply connected beams and girders. Columns that are not engaged by the braced frame can be designed as gravity load only column. Tables prepared for this publication in the Materials chapter may be used to select preliminary member sizes.

## Braced Frames — Chevron Bracing

Chevron bracing (inverted V bracing) is a modified form of a braced frame which allows for access ways to pass through a braced bay line. Figure 8 shows a typical floor framing plan with the bays using Chevron bracing denoted by the dashed-line drawn from between the two center columns. The solid lines indicate the floor beams and girders. Figure 9 shows a typical multi-floor building elevation using Chevron bracing. This system allows the architect to consider placing doorways and corridors through the bracing lines on a building.

There are two types of connections required for bracing elements. At the floor line the connection will be very similar to that required for cross-braced frames. This type of connection is illustrated in Figure 7. The connection at the floor above requires a gusset plate and field welded or bolted connection between the bracing members and the gusset plate. The depth of the gusset plate connection must be considered in the layout and coordination of mechanical ductwork and utility piping above the doorways and corridors.

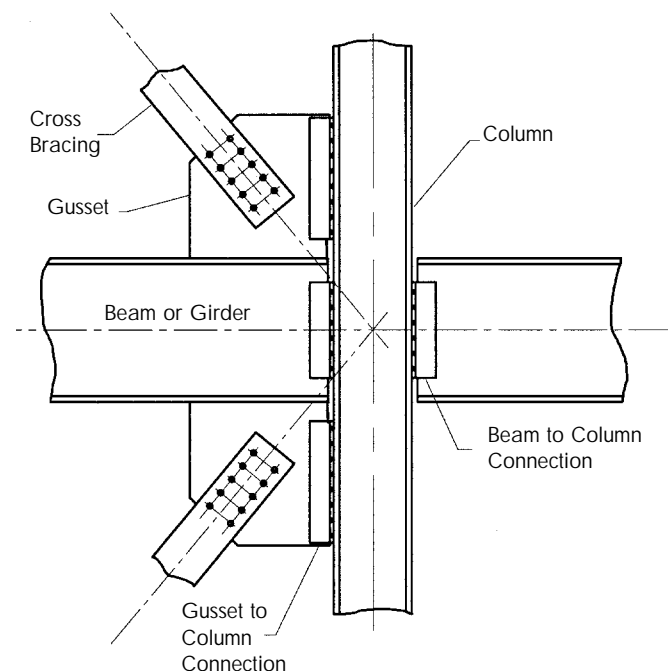
As a consequence of the bracing configuration, the bracing members are subjected to gravity compressive loads. Each of the bracing members is considered active in the analysis of the system when lateral loads are applied. As a result, the bracing elements are subjected to both tension and compressive forces.

Beams and girders used in the Chevron-braced frame are designed as two span continuous members. This will almost always result in shallower and lighter members when compared to a simple span member of equal column-to-column length.

## Eccentrically Braced Frames

Eccentrically braced frames are very similar to frames with Chevron bracing. In both systems the general configuration is an inverted V shape with a connection between the brace and the column and a connection at the beam/girder at the next level up. However, unlike the Chevron-braced frame which has the brace member workpoints intersecting at the same point on the beam/girder for the brace elements. The condition is shown in Figure 10.

This type of bracing is commonly used in seismic regions requiring a significant amount of ductility or energy absorption characteristics within the structure. The beam/girder element between the workpoints of the bracing member shown is designed to link elements and assists the system in resisting lateral loads caused by seismic activity.



**Figure 7.** Typical beam to column brace connections

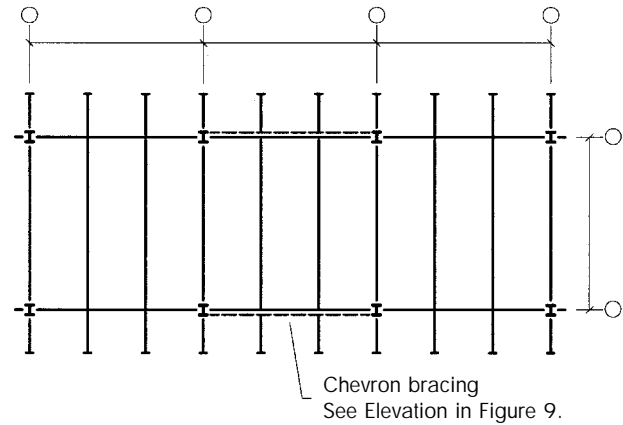


### Rigid Frames

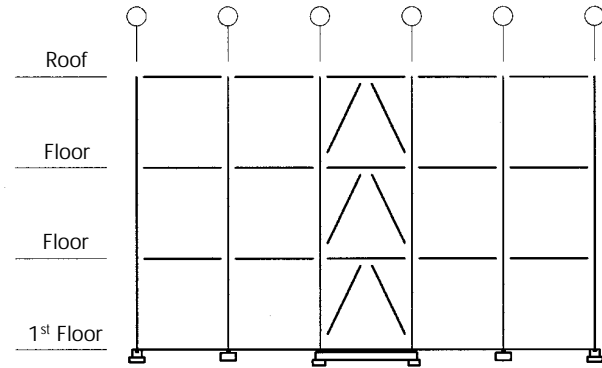
Rigid frames are used when the architectural design will not allow a braced frame to be used. This type of lateral resisting system generally does not have the initial cost savings as a braced frame system but may be better suited for specific types of buildings.

Figures 11 and 12 show a floor plan and building line elevation of a rigid frame system. Figure 11 indicates the solid triangle designation typically used to show rigid connections between beam and column as well as girder and column. The building elevation shown in Figure 12 indicates the same solid triangular symbols at the floor line beam to column joints.

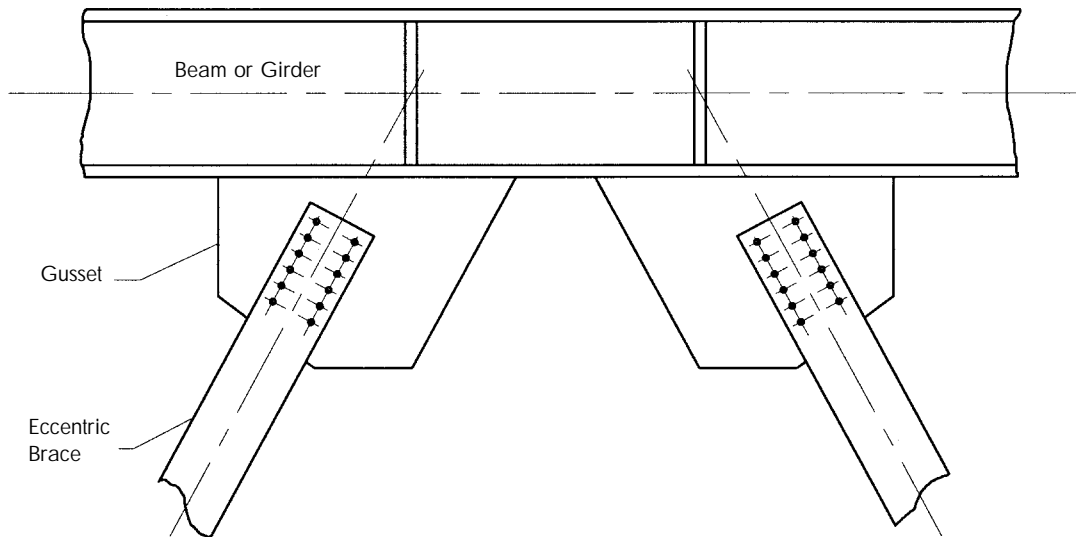
Connections between the beam/girder and column typically consist of a shear connection for the gravity loads on the member in combination with a field welded flange to column flange connection. Column stiffener plates may be required based on the forces transferred and column size. This type of joint is illustrated in Figure 13. It must be noted that this type of joint requires all vertical utility ductwork and piping to be free and clear of the column and beam/girder flanges. Coping of the beam/girder flanges to allow passage of piping or other utilities is usually not acceptable and must be brought to the attention of the structural engineer as soon as possible.



**Figure 8.** Typical floor plan with Chevron bracing



**Figure 9.** Elevation with Chevron bracing



**Figure 10.** Eccentric brace with typical brace to beam connection



### Shear Walls

This type of lateral load resisting system engages a vertical element of the building, usually concrete or masonry, to transfer the horizontal forces to the ground by a primary shear behavior. Shear walls are usually longer than they are high and are inherently stiff elements. Careful attention to detailing the joint between the shear wall and floor or roof diaphragm elements may be required. Code-specific spacing of masonry shear walls may also impact the interior layout of the building.

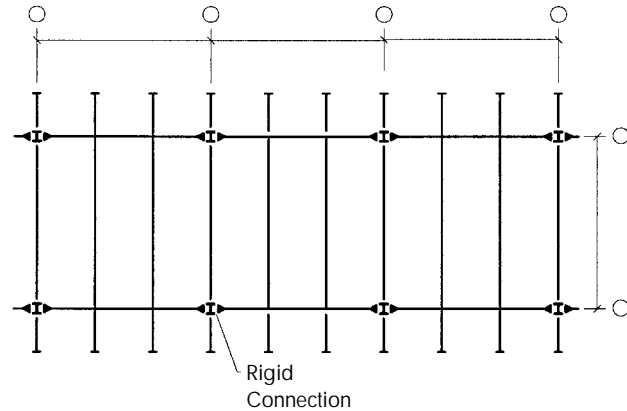


Figure 11. Typical floor plan with rigid frames

### BEAM WEB PENETRATIONS

Beam web penetrations are a way of allowing mechanical ductwork and plumbing lines to pass through structural beams and girders while maintaining a shallow ceiling sandwich and minimum floor-to-floor height. Beams and girders in buildings have, by natural consequence, regions of reserve capacity. The length of the member offers areas that can tolerate the placement of a round, square or rectangular penetration, either concentrically or eccentrically placed (see Figure 14). Concentrically placed penetrations have the centerline of the penetration matching the member depth centerline. Eccentric holes have their centerline either above or below the member depth centerline. Depending on the size, location and beam or girder, loading will determine whether the penetration should be reinforced or unreinforced. In some cases, beam

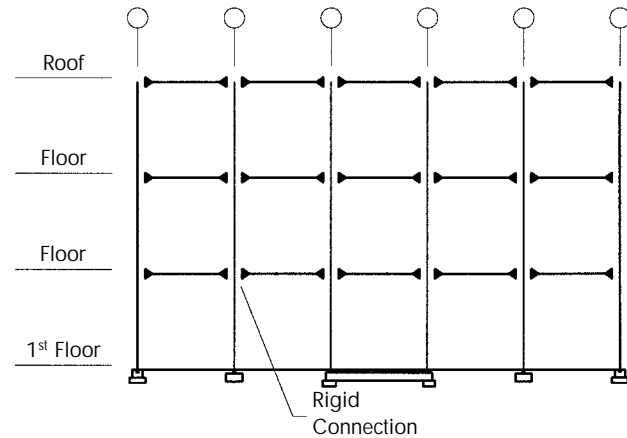


Figure 12. Rigid frame building elevation

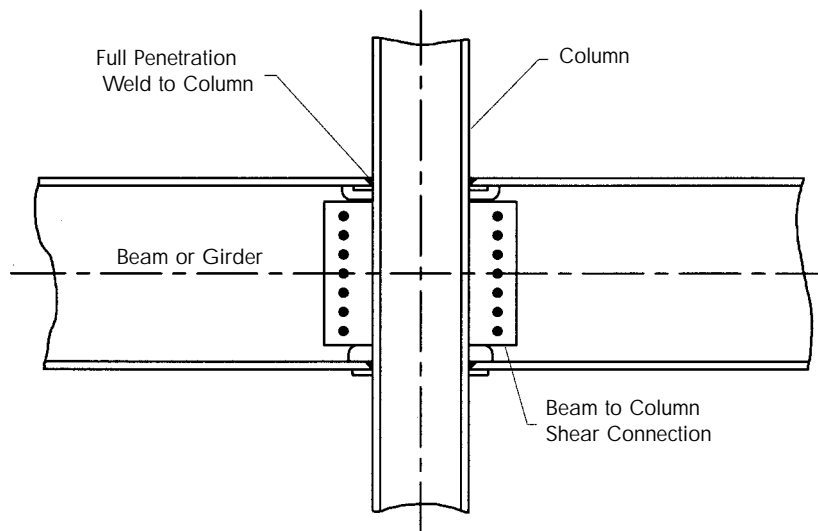


Figure 13. Typical rigid (moment) connection



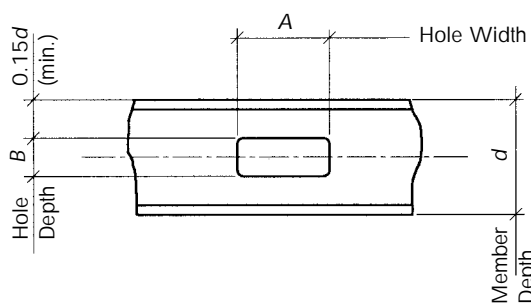
and girder penetrations may not be structurally feasible. It is important to fully discuss the size and location of all intended web penetrations early in the project with a qualified structural engineer so that the structural design may proceed and costly field installed penetrations may be avoided.

Unreinforced web penetrations are holes cut in the web of the beam or girder with no other material added to strengthen the member, as the member carries the shear and moment forces in the beam satisfactorily. These type of penetrations are the least expensive to provide. Reinforced web penetrations are required in critical structural beams and girders that are heavily loaded and/or have very large penetrations that will compromise the integrity of the member. The material taken away by the penetration may be so significant that the member shears and moments cannot be accommodated by the remaining beam or girder material alone. As a result, reinforcing material must be added.

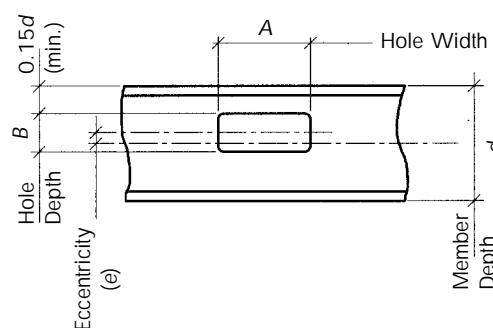
Hole reinforcing may consist of horizontal plates, a combination of horizontal and vertical plates or pipe sections for round penetration. This reinforcing is placed on one or both sides of the web. The specific structural member loading, member size, size of penetration and location of penetration will all play a role in determining the amount of reinforcing required.

As an aid to the architect in coordinating beam and girder web penetrations with the building ductwork and piping services, the following guidelines are suggested:

- Penetrations through members that have a depth-to-web thickness,  $d/t_w > 75$  should be avoided. Domestically available rolled shapes generally fall outside this criterion.
- The ratio of hole length to depth should be limited to 2.5.
- The hole depth must be limited to a maximum of 70 percent of the member depth.
- A minimum 15 percent of the member depth must remain from the edge of the hole to the outside face of the flange.
- Corners of penetrations must be made with a radius of approximately one inch. This must be considered in determining the size of penetration to accommodate ductwork and piping services.
- Concentrated loads from beams and column transfers must not be made within the length of the hole.
- Multiple holes should have a minimum two times the hole length between hole edges.
- Beams are to be laterally supported by the floor/roof construction.
- Penetrations in members that are at or near deflection limits or that have sensitive vibrations should be avoided.
- All penetrations must be investigated by a qualified structural engineer to insure the structural integrity of the member.



CONCENTRIC WEB PENETRATION



ECCENTRIC WEB PENETRATION

**Figure 14.** Concentric and eccentric web penetrations



## THERMAL MOVEMENT OF STRUCTURAL STEEL

One of the most difficult things to evaluate throughout the life of a building, and particularly during the construction period, is the amount of horizontal movement, expansion and contraction. It is difficult to design for movement since the designer cannot control some of the parameters. Expansion or contraction requirements for a structure under construction will be determined by the greatest change in temperature that the structure is exposed to prior to being enclosed and conditioned. Thermal movement is a concept that is not unique to exposed structural steel. In fact, it is not unique to steel as a building material. Movement applies to all building materials and must be accounted for in all types of construction. However, for these purposes discussion will be limited to movement of structural steel resulting from changes in temperature.

For example, it is reasonable for a steel building that is under construction in the Midwest to be erected in summer where the temperature of the steel exposed to the sun can exceed 100° Fahrenheit. The same building may not be enclosed by January, when the night temperatures can dip well below zero. The building would see a temperature change of more than 100° Fahrenheit from summer to winter.

The type of temperature differential might not appear to be significant. The integrity of the steel structure would not be affected by the thermal changes. However, the movement and stresses in the steel structure associated with a 100° change in temperature could be substantial.

The movement and changes in stress of steel are related to the steel's coefficient of linear expansion. The coefficient of linear expansion (or contraction) for any material is defined as the change in length (per unit of length) for a one degree change in temperature. The coefficient of linear expansion for steel is 0.0000065 for each degree Fahrenheit.

To determine how much a piece of steel will expand or contract throughout a change in temperature, the following equation is used:

$$\text{Change in steel length} = (0.0000065) \times (\text{Length of steel}) \times (\text{Temperature differential})$$

If a building with a large rectangular floor plan is exposed to a temperature differential of 60° Fahrenheit, and has expansion joints at every 200 ft in the long direction (see Figure 15), the horizontal movement in that direction will be as follows:

$$\begin{aligned}\text{Change in steel length} &= (0.0000065) \times (200 \text{ ft}) \times (60^\circ \text{ Fahrenheit}) \\ &= 0.08 \text{ ft} \\ &= 0.94 \text{ in.}\end{aligned}$$

It should be noted that this is the total horizontal expansion or contraction that would be expected within that temperature range. If the building were constructed during the coldest temperature of the 60° temperature range, each 200-ft segment between expansion joints would expand approximately 0.94 in. Conversely, if the building were constructed during the warmest temperature season, each 200-ft segment between building expansion joints would contract by approximately 0.94 in.

Realistically, each expansion joint in this example should be at least one-inch wide if not more. Remember, building construction tolerances must be considered, and a one-inch joint may not be sufficient. The separate sides of the expansion joint should never come in contact with each other even when the building has fully expanded. It should also be noted that the floor, wall, and ceiling finish materials that are selected to cover the expansion joints should be able to accommodate the one inch movement. This would also be true of any mechanical, electrical or plumbing components that span across the expansion joints.

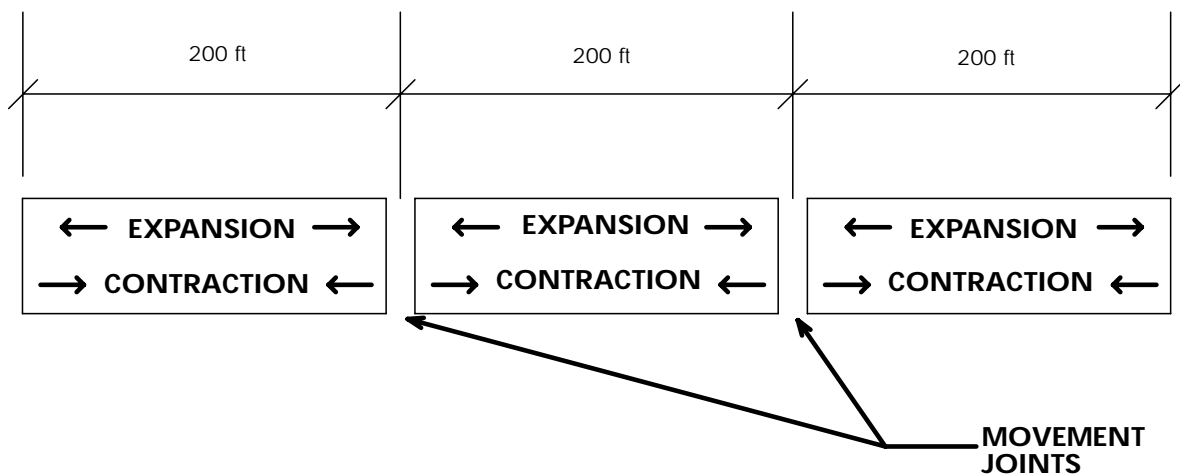


The previous example is a simplified explanation of building movement. There are, however, other factors that contribute to the "real world" thermal movement of buildings. One of those factors is the fixity of the column bases. If the column bases are "fixed", the thermal movements will be less than with "pinned" base connections. The stress in the members, however, would increase substantially. Other factors, such as whether or not the building is heated and cooled in its designed environment will have an impact on the building's movement.

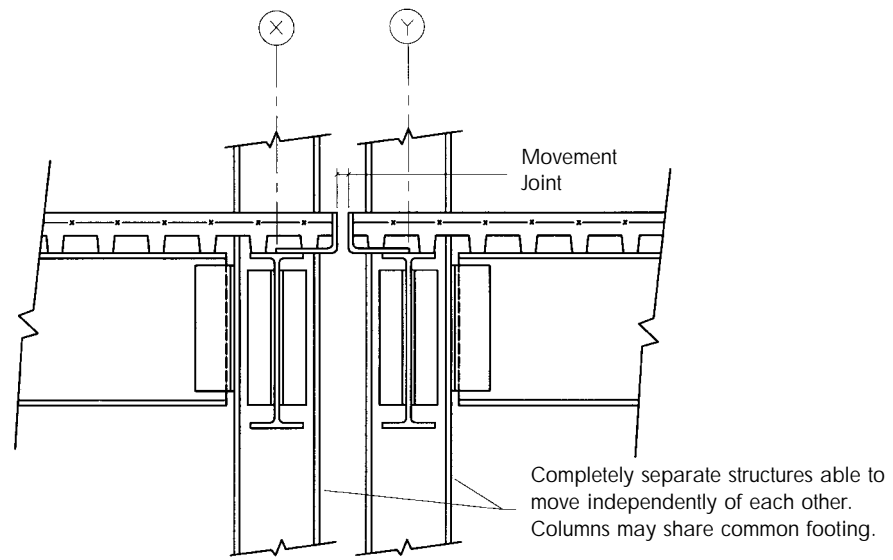
An excellent reference on the topic of thermal expansion and contraction is the Federal Construction Council's Technical Report No. 65, *Expansion Joints in Buildings*. A structural engineer should be consulted before determining expansion joint locations, sizes and spacings.

Once expansion joint locations and sizes have been determined, accommodations must be made for the movement. Basically, there are two ways to accommodate movement. One way is to provide support members such as columns on both sides of the expansion joint as shown in Figure 16. In essence, the structure on each side of the expansion joint is treated as a separate structure, free to move independently of the other side. The other approach is to make provisions for movement by allowing some of the structure to slide relative to the other while still supported on a common support. This is typically accomplished by creating a seated slide-bearing detail that is supported directly on either a column or a beam as shown in Figure 17. This alternate type of expansion joint is generally used when double columns cannot be accommodated, or where double columns in an exposed position of the building would be undesirable.

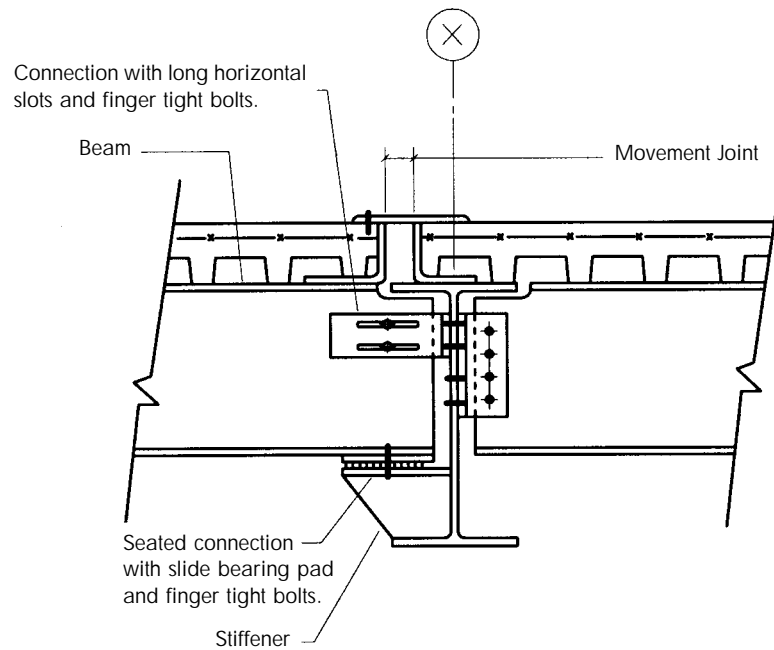
Regardless of what type expansion/contraction system is used, it cannot be overemphasized that freedom of movement must be incorporated throughout all of the building systems. Again provisions must be made for all components that cross the expansion joint.



**Figure 15.** Diagram of building expansion example



**Figure 16.** Double-column movement connection



**Figure 17.** Seated slide-bearing connection



## FLOOR VIBRATION

Movement of floors caused by occupant activities can present a serious serviceability problem if not properly considered and prevented by the design of the structural system. Humans are very sensitive vibration sensors - vertical floor movement of as little as forty thousandths of an inch can be very annoying. Post-construction repairs of floors that vibrate are always very expensive, and sometimes cannot be done because of occupancy limitations. This reinforces the necessity of addressing potential vibration problems in the original design.

The response of individuals to floor motion depends on the environment, occupant age, and location. People are more sensitive in quiet environments, such as a residence or quiet office, as compared to a busy shopping mall. The elderly are more sensitive than young adults, and sensitivity appears to increase when sitting as compared to standing or reclining.

Stiffness and resonance are dominant considerations in the vibration serviceability design of steel floor structures and footbridges. The first known stiffness criterion appeared nearly 170 years ago. In 1828, an English carpenter named Tregold published a book on carpentry writing that girders over long spans should be "made deep to avoid the inconvenience of not being able to move on the floor without shaking everything in the room." The traditional stiffness criterion for steel floors limits the live load deflection of beams or girders supporting plastered ceilings to span/360. This limitation, along with restricting span-to-depth ratios of members to 24 or less, have been widely applied to steel-framed floor systems in an attempt to control vibrations, but with limited success.

Traditionally, soldiers "break step" when marching across bridges to avoid large, potentially dangerous, resonant vibrations. Until recently, resonance had been ignored in the design of floors and footbridges. Approximately 30 years ago problems arose with the vibrations induced by walking on steel-joist supported floors that had satisfied traditional stiffness criteria. Since that time much has been learned about the loading function due to walking and the potential for resonance. More recently, new rhythmic activities, such as aerobics and high impact dancing, have caused serious floor vibrations due to resonance.

A number of analytical procedures have been developed which allow a structural designer to assess the floor structure for occupant comfort for a specific activity and for suitability for sensitive equipment. Generally, the analytical tools require the calculation of the first natural frequency of the floor system and the maximum amplitude of acceleration, velocity, or displacement for a reference activity or excitation. An estimate of the damping in the floor is also generally required. A human comfort scale or sensitive equipment criterion is then used to determine whether the floor system meets serviceability requirements. Some of the analytical tools incorporate limits on acceleration into a single design formula whose parameters are estimated by the designer.

Before presenting a technical explanation of floor design principles, basic terminology is listed and explained. A review of this terminology will greatly assist in the understanding of the structural design principles that follow.

### Basic Vibration Terminology

**Dynamic Loadings.** Dynamic loadings can be classified as harmonic, periodic, transient and impulsive as shown in Figure 18. Harmonic or sinusoidal loads are usually associated with rotating machinery. Periodic loads are caused by rhythmic human activities such as dancing and aerobics, and by impactive equipment. Transient loads occur from movement of people and include walking and running. Single jumps and heel-drop impacts are examples of impulsive loads.

**Period and Frequency.** Period is the time, usually in seconds, between successive peak excursions in repeating events. Period is associated with harmonic (or sinusoidal) and repetitive time functions as shown in Figures 18a and 18b. Frequency is the reciprocal of period and is usually expressed in Hz (Hertz or cycles per second).





**Steady State and Transient Motion.** If a structural system is subjected to a continuous harmonic driving force (see Figure 18a), the resulting motion will have a constant frequency and constant maximum amplitude and is referred to as steady state motion. If a real structural system is subjected to a single impulse, damping in the system will cause the motion to subside as illustrated in Figure 19. This is one type of transient motion.

**Natural Frequency and Free Vibration.** Natural frequency is the frequency at which a body or structure will vibrate when displaced and then quickly released. This state of vibration is referred to as free vibration. All structures have a large number of natural frequencies; the lowest or "fundamental" natural frequency is of most concern.

**Damping and Critical Damping.** Damping refers to the loss of mechanical energy in a vibrating system. Damping is usually expressed as the percent of critical damping or as the ratio of actual damping to critical damping. Critical damping is the smallest amount of viscous damping for which a free vibrating system that is displaced from equilibrium and released comes to rest without oscillation.

**Resonance.** If a frequency component of an exciting force is equal to a natural frequency of the structure, resonance will occur. At resonance, the amplitude of the motion can become very large as shown in Figure 20.

**Step Frequency.** Step frequency is the frequency of application of a foot or feet to the floor, e.g., walking, dancing or aerobics.

**Harmonic.** A harmonic multiple is an integer multiple of the frequency of application of a repetitive force (e.g., multiple of step frequency for human activities or multiple of rotational frequency of reciprocating machinery). Harmonics can also refer to natural frequencies, e.g., of strings or pipes.

**Mode Shape.** When a floor structure vibrates freely in a particular mode, it moves up and down with a certain configuration or mode shape. Each natural frequency has a mode shape associated with it. Figure 21 shows typical mode shapes for a simple beam and for a slab/beam/girder floor system.

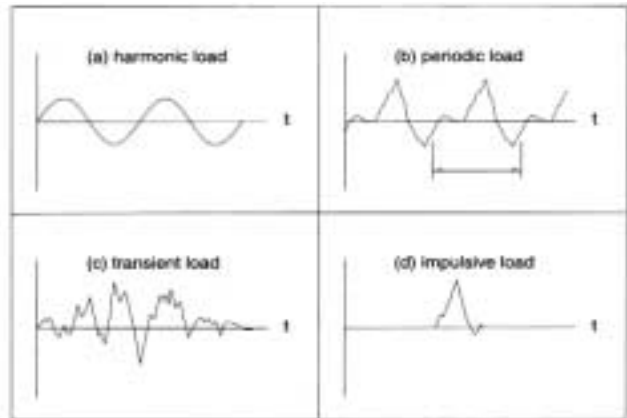


Figure 18. Types of dynamic loading

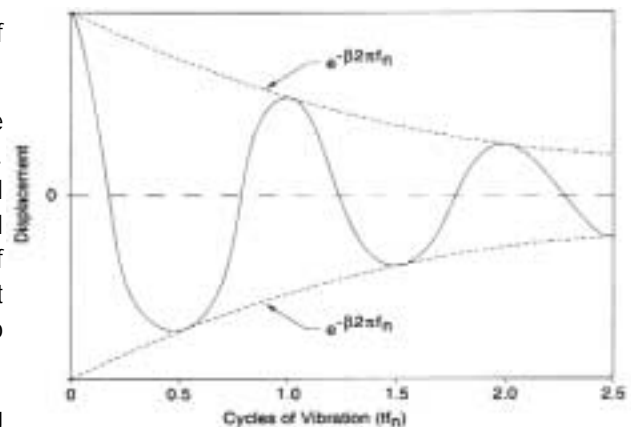


Figure 19. Decaying vibration with viscous damping

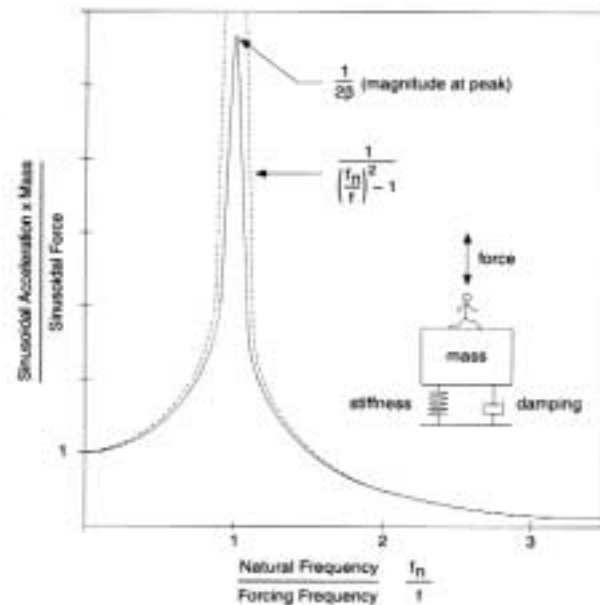


Figure 20. Response to sinusoidal force



**Modal Analysis.** Modal analysis refers to a computational analytical or experimental method for determining the natural frequencies and mode shapes of structures, as well as the responses of individual modes to a given excitation.

**Spectrum.** A spectrum shows the variation of relative amplitude with frequency of the vibration components that contribute to the load or motion. Figure 22 is an example of a frequency spectrum.

**Acceleration Ratio.** The acceleration of a system divided by the acceleration of gravity is referred to as the acceleration ratio. Usually the peak acceleration of the system is used.

**Floor Panel.** A rectangular plan portion of a floor encompassed by the span and an effective width is defined as the floor panel.

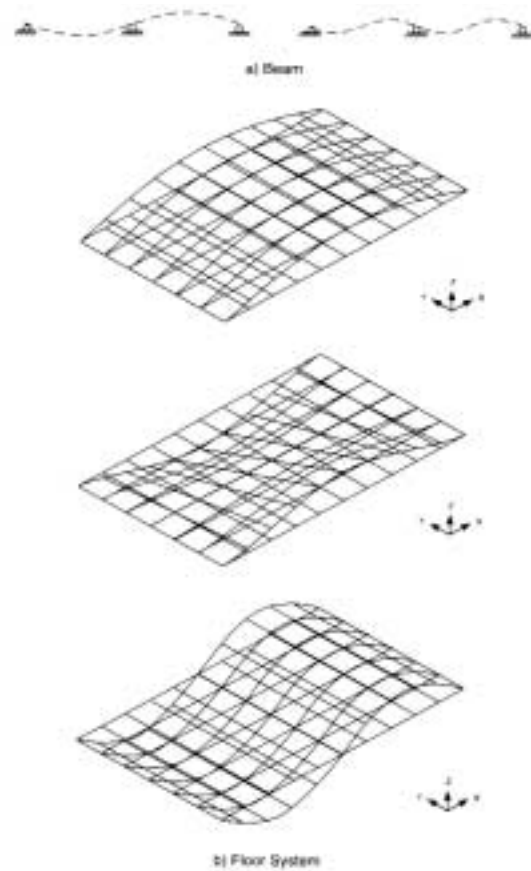
**Bay.** A rectangular plan portion of a floor defined by four column locations.

### Floor Vibration Principles

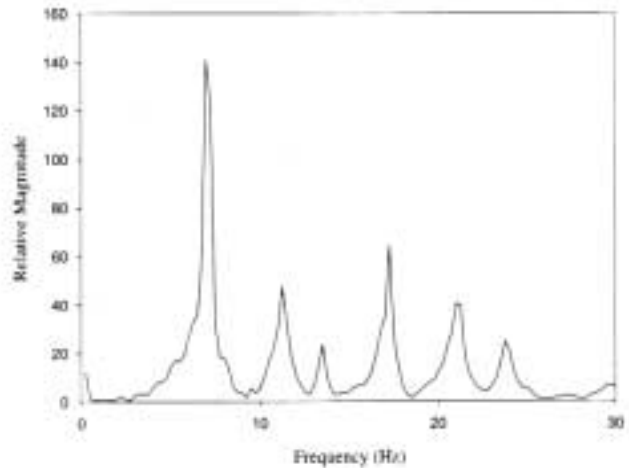
Although human annoyance criteria for vibration have been known for many years, it has only recently become practical to apply such criteria to the design of floor structures. The reason for this is that the problem is complex, the loading complex, and the response complicated - involving a large number of modes of vibration. Experience and research have shown, however, that the problem can be simplified sufficiently to provide practical design criteria.

Most floor vibration problems involve repeated forces caused by machinery or by human activities such as dancing, aerobics or walking, although walking is a little more complicated than the others because the forces change location with each step. In some cases, the applied force is sinusoidal or nearly so.

AISC's Steel Design Guide No. 11: *Floor Vibrations Due to Human Activities* explains in detail the required engineering calculations and assessment techniques. These techniques use acceleration, as a percent of acceleration due to gravity, to measure human perception of floor movement. For example, the tolerance level for quiet environments, residences, offices, churches, etc. is 0.5 percent of gravity ( $0.005g$ ).



**Figure 21.** Typical beam and floor system mode shapes



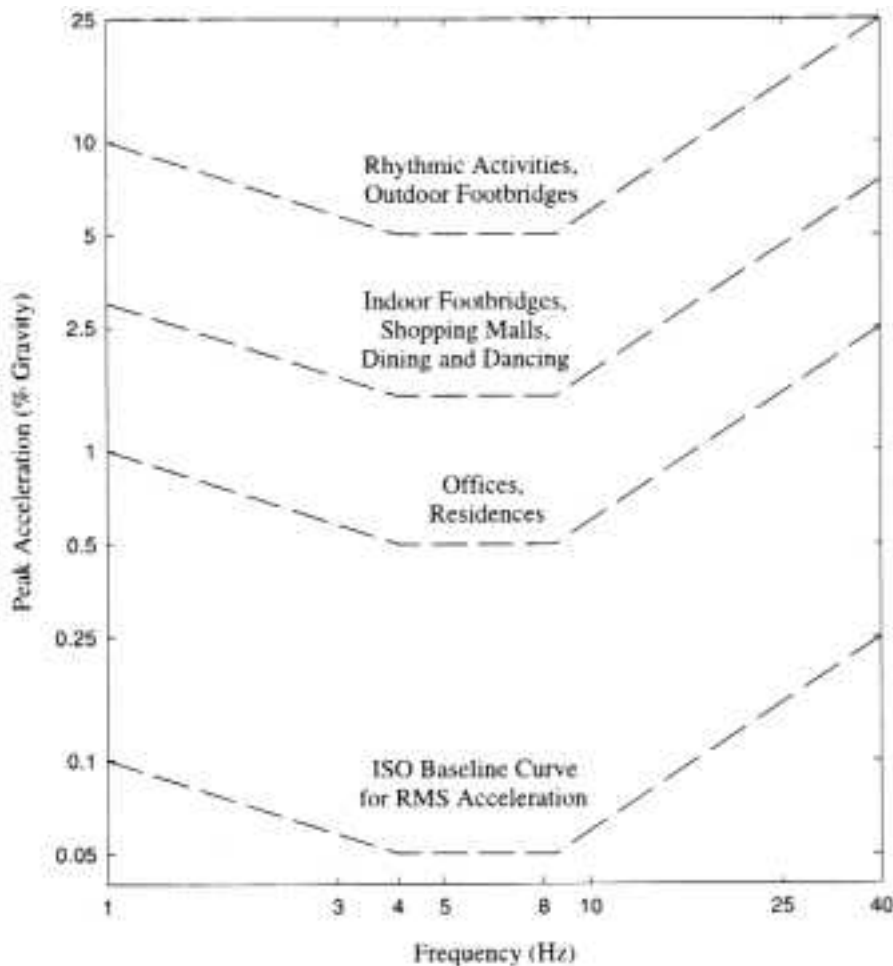
**Figure 22.** Frequency spectrum



Figure 23 shows tolerance levels for a number of situations. Note that the scale is a function of frequency and acceleration. Also, note that the tolerance acceleration level increases as the environment becomes less quiet. For instance, the tolerance level for people participating in aerobics (rhythmic activities) is ten times greater than if they are in a quiet office. To use the scale, the natural floor frequency and the estimated acceleration for an activity must be calculated.

The acceleration of a floor system depends on the activity, the natural frequency for the floor, the amount of mass that moves when the floor vibrates, and the damping in the floor. Floor acceleration increases as energy in the activity increases; thus, floor acceleration is greater for aerobics than for walking. Acceleration decreases with increasing weight; the acceleration for a lightweight concrete floor will be greater than that for the same normal weight concrete floor for the same activities. Acceleration decreases with increasing damping.

Evaluation of a floor system for potential annoying vibration requires careful estimation of the weight supported by the floor on a typical day. A fully loaded floor will never be a problem; most occupant complaints are received when the problem floor is slightly loaded. The design dead load for mechanical equipment and ceiling should never be used, nor should the design live load. An estimate of the real mechanical loading (for instance, 2 psf not 5 psf as may be used for strength design) and ceiling is required. Recommended live loads in the Floor Vibrations design guide are 11 psf for office live loading (not 50 psf as used for strength design), 6 psf for residences, and 0 psf for shopping malls.



**Figure 23.** Recommended peak acceleration for human comfort for vibrations due to human activities (International Standards Organization [ISO], 2631-2: 1989)



Frequency is the rate at which a floor vibrates and is expressed in cycles per second (Hz). Floor systems generally have a frequency between 3 and 20 Hz. For a typical steel framed 30 ft by 30 ft office building bay, the frequency will be in the 5-8 Hz range. Frequency is a function of span (the longer the span, the lower the frequency) and weight supported (the heavier the floor and the supported contents, the lower the frequency). Thus, a floor constructed using normal weight concrete will vibrate at a lower frequency than the same floor constructed with lightweight concrete. When the frequency is above 15 Hz, as occurs in very short spans (say less than 15 ft), floor vibrations are generally not felt.

Damping is energy loss due to relative movement of floor components or fixtures on the floor. Damping causes a freely vibrating floor system to come to rest and is usually expressed as a percent of critical damping. Critical damping is the amount of damping required to bring a vibrating system to rest in one-half cycle. Damping for floors is usually between 2 percent and 5 percent. The lower value is for floors supporting few non-structural components, like for open work areas and churches. The larger value is for floors supporting full-height partitions. A typical office floor with movable, half-height partitions has about 3 percent damping.

Particular attention should be given to office floors with open spaces, no fixed partitions, and light loads. This situation is what results in problem floors if the design is not done correctly. Also, floors with high design loads (say 125 psf) and light actual loads (say less than 15 psf) do not have the same amount of damping as floors designed for normal office loading (say 50 psf). In this case, a lower estimate of damping should be used (e.g., 1-2 percent).

The design of floors supporting rhythmic activities, dancing, aerobics, etc. require consideration of the entire structure, not just the supporting floors. These activities introduce very high energy levels into the structure and can cause annoying floor motion quite some distance from the activity area. Aerobics on the 60<sup>th</sup> floor of a building have caused excessive floor motion twenty floors below. When a rhythmic activity floor is located above approximately six stories, column deflections must be considered.

To avoid annoying vibrations in floors supporting rhythmic activities, the fundamental natural frequency must be above frequencies associated with harmonics of the activity and the tolerance acceleration ratio. The tolerance acceleration ratio is a function of both the rhythmic activity and the affected occupancy. For instance, when dancing and dining are considered, the tolerance acceleration ratio is 0.02*g*. The tolerance level is increased to 0.05*g* for participants in lively concerts or sports events.

To satisfy the criterion, a relatively large fundamental natural frequency is required. For example, if jumping exercises are shared with weightlifting with an acceleration tolerance level of 0.02*g* and floor weight of 50 psf, the required frequency is 10.6 Hz. The economical solution for this example is lightweight concrete and deep, lightweight supporting members.

Floors supporting sensitive equipment, such as operating room equipment, electron microscopes, and microelectronics manufacturing equipment must be very stiff and heavy. Tolerance levels for this type of equipment are usually expressed in velocity with numbers like 100 to 8,000 micro-in./second. The means of accommodating sensitive equipment are readily available, but usually require specialists in this area to produce a satisfactory design.

## Summary

The determination of potentially annoying floor motion for a proposed design requires careful consideration of the structural system, the anticipated activities, and the finished space. Art, as well as science, is required on the part of the designer. The most important parameter to be determined is the fundamental natural frequency of the floor structure. This calculation requires a careful estimate of the supported weight on an average day. Floor system damping, which depends on the components of the building systems, as well as occupancy furnishings and partitions, also must be estimated. Finally, an acceleration tolerance criterion must be selected and compared to the predicted acceleration of the floor structure.



## PART II

# PROTECTING STRUCTURAL STEEL

## GUIDE TO COATINGS TECHNOLOGY

It is not always necessary to paint or coat structural steel; e.g., when the structure is hidden and protected from moisture, it is protected with spray-applied fire protection or aesthetics do not require it. These specific conditions will be clearly explained in this section.

There are many times, however, when the steel structure must be protected against corrosion; e.g., when it is architecturally exposed. Over the past few years, great strides have been made in the development of high-performance coatings leading to the increased use of exposed steel as a means of architectural expression. Steel's high strength-to-weight ratio allows thin and elegant forms to support large loads and span long distances. The ability to have long-term protection on exposed structural steel has allowed many of today's innovative architects to express a wide variety of ideas through the structure itself. Properly specified and applied coating systems can be expected to give 20 to 25 years of initial service life that can be extended almost indefinitely and with subsequent maintenance painting.

Coatings technology continues to evolve with paint systems being developed to meet more and more stringent requirements. This is a blessing in the sense that owners and architects can expect continually improving performance, but it also means that developing a proper specification for a given project requires keeping up with the most recent product developments.

Paint specifications for building structures should be performance-based to allow competition within a performance standard. Paint specifications should also be project specific and take into account the following three factors:

- Building end-use—Is it a factory where the structure will be exposed to corrosive processes or high humidity? Is it a public facility subject to abrasion and vandalism (graffiti)? Is it a swimming pool with high humidity and heat? Or, is it an office building that is well-protected and subject to benign usage?
- Environment—Is the building located on the coast in a saline atmosphere, at an inland location surrounded by industrial plants, or is it in a desert-dry climate but subjected to relentless attack by the ultra-violet rays of the sun?
- Is the structure to be exposed on the exterior, interior or both?

This portion of the guide is intended to inform architects of issues that should be considered in the development of a proper paint specification for building structures. In addition, there is considerable background information intended to help specifiers understand coating systems in general so that they can make informed and intelligent choices. Several coating references are provided at the end of this section.

## BASICS OF PROTECTIVE COATINGS

### The Corrosion Process

A clear understanding of the corrosion process is essential to understand the steps to inhibit corrosion with protective coatings.



Oxygen combines with iron, the major element in steel, to form rust. This electrochemical process returns the iron metal to the state that it existed in nature—iron oxide. The most common form of iron oxide or iron ore found in nature is hematite ( $\text{Fe}_2\text{O}_3$ ), which is equivalent to what we call rust. Iron in iron ore is separated from the oxide to yield usable forms of iron, steel and various other alloys through rigorous electrochemical reduction processes. Because the iron has a strong affinity for oxygen, it is necessary to deal with the ever-present tendency to form the more electrochemically stable iron oxides.

The process of combining iron and oxygen, called oxidation, is accompanied by the production of a measurable quantity of electrical current, which is why this is called an electrochemical reaction. For the reaction to proceed, an anode, a cathode and an electrolyte must be present. This is termed a corrosion cell. In a corrosion cell, the anode is the negative electrode where corrosion occurs (oxidation), the cathode is the positive electrode end, and the electrolyte is the medium through which an electrical current flows.

### Coatings in Corrosion Control

A coating may be defined as a material which is applied to a surface as a fluid and which forms, by chemical and/or physical processes, a solid continuous film bonded to the surface.

Eliminating any of the reactants in the process can interrupt corrosion. If a barrier is put on to the iron that prevents oxygen and/or water from coming in contact with steel, the corrosion process can be prevented. Steel is not the only surface protected by such barriers. Other alloys and metals such as stainless steel, brass, aluminum and other materials such as concrete, wood, paper, and plastic are also protected from the environment with coatings. Protective coatings that serve as barriers are the principal means of protecting structures.

### COMPOSITION OF COATINGS

Most coatings are made up of four principal parts: pigments; non-volatile vehicles (resins or binders); volatile vehicles (organic solvents, water or the combination of both); and additives (specialty chemicals which make the coating function). All of the components of a coating interact to accomplish the purpose for which the coating was designed.

#### Pigments

Pigments are included in coatings to perform any of the following functions:

- Add color
- Adjust the flow properties of wet coatings
- Resist light, heat, moisture, chemicals
- Inhibit corrosion
- Reflect light for opacity or hiding
- Contribute mechanical strength

Pigments whose prime function is to contribute opacity to coatings are called hiding or prime pigments. The principle white-hiding pigment is titanium dioxide. There are hundreds of colored-hiding pigments which, when used alone or combination with other pigments, give coatings their variety of colors. Hiding pigments can be very



expensive. In order to make the paint less costly, non-hiding or extender pigments are used. Certain colors, such as light-stable reds, are more expensive. Determine costs from your coating supplier prior to writing the project specification.

Pigments are used to adjust the viscosity and flow properties of the paint in order to obtain paint that won't sag at high film builds. Using pigments with low oil absorption can decrease the amount of solvents in the paints. Pigments used to reduce or prevent corrosion of a coated surface are called inhibitive pigments.

Pigments help protect the resin in the film from degradation of solar radiation. Hiding pigments do the best job of protecting the resin from the harmful portion of solar radiation by blocking its penetration into a film. Pigments in the film also inhibit penetration of corrosive elements, thus protecting the substrate. Pigments also can add mechanical reinforcement to a film, adding strength, flexibility, and abrasion resistance.

### **Non-Volatile Vehicles (Binders)**

The binder or resin portion (polyurethane, epoxy, etc.) of the coating is the "glue" that holds the coating together and onto the substrate. The physical properties of the coating are mainly derived from the physical properties of the solid resin, but pigments and additives can affect the final properties. Coatings are generally named after the type of resin used as the coating binder.

Resin binders change from the liquid to the solid state by several different drying curing mechanisms:

- Lacquer, dispersion and latex paints dry through the evaporation of solvent and/or water.
- Vegetable oil and alkyd paints harden through oxidative cure.
- Two-component chemically reactive paints harden through chemical cure, i.e., two components are mixed prior to application and polymerize on the substrate, e.g., epoxy or polyurethane.
- One-component chemically reactive paints harden through the reaction of a resin that has an active chemical group, with atmospheric moisture releasing a new chemical group that causes the resin to crosslink.

The simplest drying mechanism is evaporation of the volatile vehicle. Solventborne lacquers generally have very high solvent content because very hard resins needed for good film protection require a lot of solvent to reduce the paint viscosity to application consistency. Vinyl and chlorinated rubber coatings are examples of resins relying on solvent evaporation.

Another type of paint that dries through simple evaporation of the volatile vehicle is waterborne paint. Here a major portion of the volatile vehicle is water which acts to lower the viscosity of the paint. Acrylic and vinyl latexes, water-based epoxies and polyurethane dispersions are examples of this technology.

Coatings based on natural oils or alkyd binders modified with drying oils develop their film properties principally through oxidative curing. Atmospheric oxygen creates active crosslinking sites on vegetable oil or the drying oil portion of the synthetic resin. These sites connect to form a three dimensional, chemically bonded network. Linseed, alkyd and epoxy ester binders are examples of systems that cure by a combination of solvent evaporation and oxidation.

Two-component chemically reactive paint is manufactured and sold in two separate containers. The two multi-functional reactive resinous materials are mixed together just prior to use. The two resins immediately begin to react together to form a polymeric matrix. During polymerization, the paint viscosity will increase. This means that the paint has a specific use life before the paint will gel. Polyurethane and epoxy are examples of these coatings.



One-component chemically reactive paint utilizes polyisocyanate chemistry. The isocyanate group reacts with atmospheric moisture to yield an amine group. The amine reacts very rapidly with additional isocyanate to form a urea crosslink. This paint offers the ease of use of other one-component technologies with the performance of a two-component paint. Moisture-cured polyurethane technology is a rapidly growing example of this technology.

### **Volatile Vehicles (Solvents)**

A solvent is used to dissolve the resins and additives in order to reduce the viscosity of the mixture to provide application consistency and allow the paint to flow out properly. In every case, it is designed to evaporate from the film during or after application.

Solvents are also used in waterborne dispersions and latexes. At some point in either the manufacture of the resin or the paint, solvents are added to soften the resin. During the drying of the paint film, the water evaporates. The dispersion of latex particles come into contact and flow together to form a continuous film. Finally the solvent evaporates from the film. This process, called coalescence, would not take place without the solvent. Resins that are hard enough to produce through tough films are too hard to coalesce without the solvent. Waterborne coatings are gaining interest by specifiers because they are perceived as being environmentally friendly. Although many waterborne coatings do have low levels of solvents, some waterborne paints contain solvent in amounts equivalent to those in high-solid, solventborne coatings.

Environmental concerns are forcing raw material suppliers and paint producers to lower the solvent content of the products they supply in order to reduce the amount of volatile organic compounds (VOCs) released into the atmosphere.

Coatings suppliers select the type of solvent suitable for each type of coating formulation. The choice of solvents is made based on the optimum paint viscosity and evaporation rate that result in proper paint flow and thus, the intended appearance and adhesion. Coating applicators may need to add solvents during application to control viscosity over the various temperature ranges encountered in the field.

The wrong choice of solvents can jeopardize an application. If the chosen solvent evaporates too fast, bubbles caused by the vapor pressure of the solvent may appear in the surface. If the coating is spray applied, the solvent may "flash out" of the spray mist before it reaches the surface, and the spray may become too dry for the paint particles to flow together. This effect is called dry spray. A solvent that is too slow to evaporate may remain in the film too long, causing sags and runs and resulting in a film that is soft and has other altered performance properties.

The applicator must also take care not to add thinning solvent beyond that recommended by the manufacturer, because the paint viscosity may be so slow that the wet films will sag and run. Over-thinned paint that is applied at too low a film build may result in films that are too thin and have no hiding power.

### **Additives**

Additives make up only a small proportion of any paint. Yet without these chemicals the paint could not deliver all of its potential performance.

Paint additives are used to aid pigment grinding, stabilize resin and pigment dispersions, break foams, aid flow, prevent film surface defects, catalyze chemical reactions, prevent oxidation, enhance adhesion, provide slip and abrasion resistance to the film surface, prevent corrosion, and to improve weathering resistance and enhance color retention.





These additives can be inexpensive or can be the most expensive component on a per pound basis of any ingredient. In these days of cost competition, it is not unusual for a paint manufacturer to cut costs by leaving out one of these vital ingredients. Sometimes the effects may not be known until years after the paint application. For example, in a high performance polyurethane topcoat, it is usual practice to add antioxidants and UV absorbers to enhance the weathering resistance. If these additives are left out of the formulation to lower cost, instead of the ten years of gloss and color retention, only one or two years might be expected. *It is imperative that expected paint performance be listed in the job specification.*

## TYPES OF COATINGS

### Zinc-Rich Primers

Zinc has been the most successful coating material for steel protection.

The English started with the idea of using zinc dust in organic vehicles to provide a zinc-rich coating. A completely different concept was started in Australia where the inorganic zinc-rich materials were developed. The idea of incorporating zinc dust into an organic vehicle coincided with the time that the more sophisticated synthetic resins became available.

Two categories of zinc-rich primers are available based on the binder chemistry. *Inorganic zinc* coatings are composed of powdered metallic zinc mixed into a reactive silicate solution. Those formed from sodium silicate, potassium silicate, lithium silicate, colloidal silica, the various organic silicates, and even galvanizing, are reactive materials from the time they are applied.

The second category is *organic zinc-rich* primers, the binders of which are based on organic or carbon-based compounds. Organic vehicles include phenoxyes, catalyzed epoxies, urethanes, chlorinated rubbers, vinyls, and other suitable resinous binders.

One very important characteristic of inorganic zinc coatings is the electrical conductivity of the matrix. Electrons formed by ionization of zinc at any point within the coating can migrate to the steel substrate and provide cathodic protection to any steel area that may be exposed. Particle-to-particle contact of the zinc pigment is not required for conductivity in inorganic zinc coatings since it is in a conductive, organic zinc-rich matrix. Organic rich coatings generally require a higher zinc loading to develop the zinc particle contact necessary for protection.

### Epoxy

Epoxy binders are available in three types: *epoxy ester*; *epoxy lacquer resin*; and *two-component epoxy*.

The two-component epoxies are most commonly used for painting structural steel. Epoxy resins of this type can cure by chemical reaction. The epoxy is generally combined with either of two types of hardeners (polyamine or polyamide) to form *epoxy-polyamine* and *epoxy-polyamide*.

Epoxy-polyamine blends are more resistant to chemicals and solvents and are often used for lining tanks. Epoxy-polyamide paints are the most popular of all epoxy binders for use on structural steel. When exposed to weathering, they chalk quickly, but retain excellent chemical and abrasion resistant properties.



## Acrylics

Acrylics can be supplied as solvent- or water- based coatings with varying performance characteristics. They exhibit good color and gloss retention, are single package, relatively low in cost and easy to apply. Solvent and chemical resistance, however, is lacking. They are best for interior, non-corrosive environments.

## Polyurethane

Polyurethane binders are available in two types for painting structural steel:

- Moisture-cure polyurethane
- Two-component polyurethane

### *Moisture-Cure Polyurethane*

Reacts with air moisture to cure. They produce the hardest, toughest coatings available in one package, and are increasingly popular due to the wide range of application and productivity advantages:

- Can be applied to cold damp surfaces
- Can be applied at temperatures below freezing
- No dew point restriction
- Year round application season
- Excellent recoatability
- Single component

### *Two-Component Polyurethane*

Polyurethanes can also be reacted with products such as polyols, polyethers, polyesters or acrylics to produce extremely hard, resistant durable coatings. These are commonly used as topcoats.

## Alkyds

Alkyds are available in both water dispersion and solvent-based formulations. Alkyd-oil vehicles can be formulated in flat and semi-gloss finishes over a wide compositional range. Generally, alkyds have poor color and retention properties and tend to chalk when exposed to sunlight. Their primary advantage is low cost.

## PAINTING GUIDES

Sample painting guide specifications have been included at the end of the coatings technology section. Other coatings technologies can be considered. Consult your painting supplier for recommendations based on specific project requirements.



## SPECIAL PURPOSE COATING SYSTEMS

### Intumescent Paint

Intumescent paints are examples of special purpose coating systems. They can provide fire ratings for exposed steel for up to three hours. See the later section called "FIRE PROTECTION" for additional information on intumescent paints.

### Hot-Dip Galvanizing

There are several reasons for selecting galvanizing as a coating system. For light fabrications and some medium structural applications, galvanizing can be the lowest cost coating system. It is usually also one of the lowest long-term cost coating system alternatives. Galvanizing does not adhere to the steel, but is actually metallurgically bonded to the base steel—forming an alloy layer between the surface zinc and the underlying base metal. Galvanizing is a tough coating system, providing high resistance to mechanical damage in transport, erection and in service. Finally, galvanizing eliminates maintenance for relatively long periods of time. This can be a significant factor if maintenance of the facility requires shutdowns or the area to be maintained is not easily accessible.

There are several types of galvanizing processes that are used throughout the industry including electric, zinc plating, mechanical plating and hot dip galvanizing. Hot-dip galvanizing is one of the oldest and most common types and has been used to fight corrosion for more than 200 years.

Hot-dip galvanizing is a process in which a steel article is cleaned in acid (pickled) and then immersed in molten zinc that is heated to approximately 850° Fahrenheit. This results in formation of a zinc and a zinc-iron alloy coating that is metallurgically bonded to the steel. After the steel is removed from the galvanizing bath, excess zinc is drained or vibrated off the steel member. The galvanized member is then cooled in air or quenched in water. The zinc coating acts as a barrier that separates the steel from the environmental conditions that can cause corrosion. The galvanizing process precludes the possibility of coating improperly prepared steel surfaces, since the molten zinc will only react with clean steel. Due to the immersion process, galvanizing also provides complete protection of all galvanized parts—including recesses, sharp corners, and inaccessible areas.

Today, almost any size item can be galvanized. Most galvanizing facilities have galvanizing kettles that are at least 30 ft in length. Larger kettles of up to 50 ft long are becoming common. If an item is too long for total immersion at one time, it may still be possible to galvanize the item. If more than one half of the item will fit into the kettle, a process called "double dipping" may be incorporated. Double dipping is a process where one half of the item is dipped in the kettle filled with molten zinc and withdrawn, and then the other half is dipped. The double dipping process provides a constant thickness of zinc coating similar to the total immersion process. Consult a galvanizer before planning to use a "double dipping" process.

Sometimes it is necessary to prevent the zinc coating from bonding to a local portion of the steel article. An example of this situation would be where something needs to be welded to the galvanized article, since the zinc coating could contaminate the welds. This concept would also apply to galvanized beams where the top flange must remain ungalvanized to receive shear connectors for a composite beam. Today there is a technology that can incorporate the hot-dip galvanizing process while leaving predetermined areas of the article uncoated. This process can be applied in any location, on any size or shape of steel members. Consult a local galvanizer for more information on this topic.



If aesthetics are an important issue for the galvanized item, the architect should indicate suitable locations to the galvanizer. Since all of the material is immersed into the galvanizing kettles, chains, wires or other holding devices are needed to support the immersed articles. Holding devices usually leave marks on the finished galvanized product. These marks are not necessarily detrimental to the coating, but could affect the desired aesthetics.

Best results for galvanizing will occur when the architect and fabricator keep the nature of the galvanizing process in mind at all stages. To minimize any warping that may result from the galvanizing process, the item to be galvanized should be fabricated so that it can be quickly and completely immersed in the kettle. Use of symmetrical sections in lieu of unusual angles or channels will minimize shape warping. For more information on galvanizing characteristics, consult a local galvanizing company.

In any building there are many areas susceptible to corrosion that warrant special protection through galvanizing. The two-page Figure 24 illustrates high potential corrosion areas on high-rise buildings where galvanized protection is advised. An example of a building design galvanizing checklist is also given in Figure 25. Additional information on galvanizing is available from the American Galvanizers Association (AGA). Contact information for AGA is given in the Appendix.

### Galvanized Steel — Painted (Duplex System)

Sometimes it is desirable to provide a coating system for steel that includes both galvanizing and paint systems. There are several reasons why it would be desirable to combine these materials: aesthetics, color coding, safety markings, ease of repairing, and low life-cycle costs are just a few. This combination of galvanizing and paint systems is known as a duplex system.

The key to success of a duplex system is proper surface preparation and proper selection of a paint system. Simply stated, the galvanized system must be clean, and the paint system must be compatible with zinc. Previous difficulties with paint adhesion on hot-dipped galvanized surfaces were related to three factors:

- Lack of surface profile on newly galvanized surfaces
- Reaction between paint components and zinc (wrong choice of coatings)
- Surface contamination between painting and galvanizing

Today, these difficulties can be overcome. The lack of surface profile can be overcome by brush-blasting or chemical etching treatments of the galvanized surface. The reactions between components of paint can be overcome by properly specifying paints that do not contain vegetable oil-based vehicles (alkyds), which destroy the zinc bond. Finally, proper solvent washing prior to painting can control the surface contamination between galvanizing and paints.

In many cases, a piece of steel that has been galvanized and painted can provide synergistic benefits in protection to the steel. There is evidence that protection provided by painting galvanized steel is greater and lasts longer than the sum of the protection provided separately by zinc or paint alone. *The protection is typically 50 percent greater than the additive effects of zinc and paint topcoating.*

If steel is galvanized and painted, any corrosion resulting from the eventual broken barrier is limited to the surface of the exposed areas and does not cause undercutting, blistering or flaking of the paint. Actually, galvanized products retard further damage to the steel by sealing pores and cracks in the paint film. At the same time, paint actually extends the life of the underlying galvanized coating by postponing degradation of the zinc layer.

The selection of a suitable painting system is critical for the successful painting of galvanized steel. Loss of adhesion often occurs when incompatible systems, such as alkyd resin-based paints, epoxy resin-based paints or acrylate

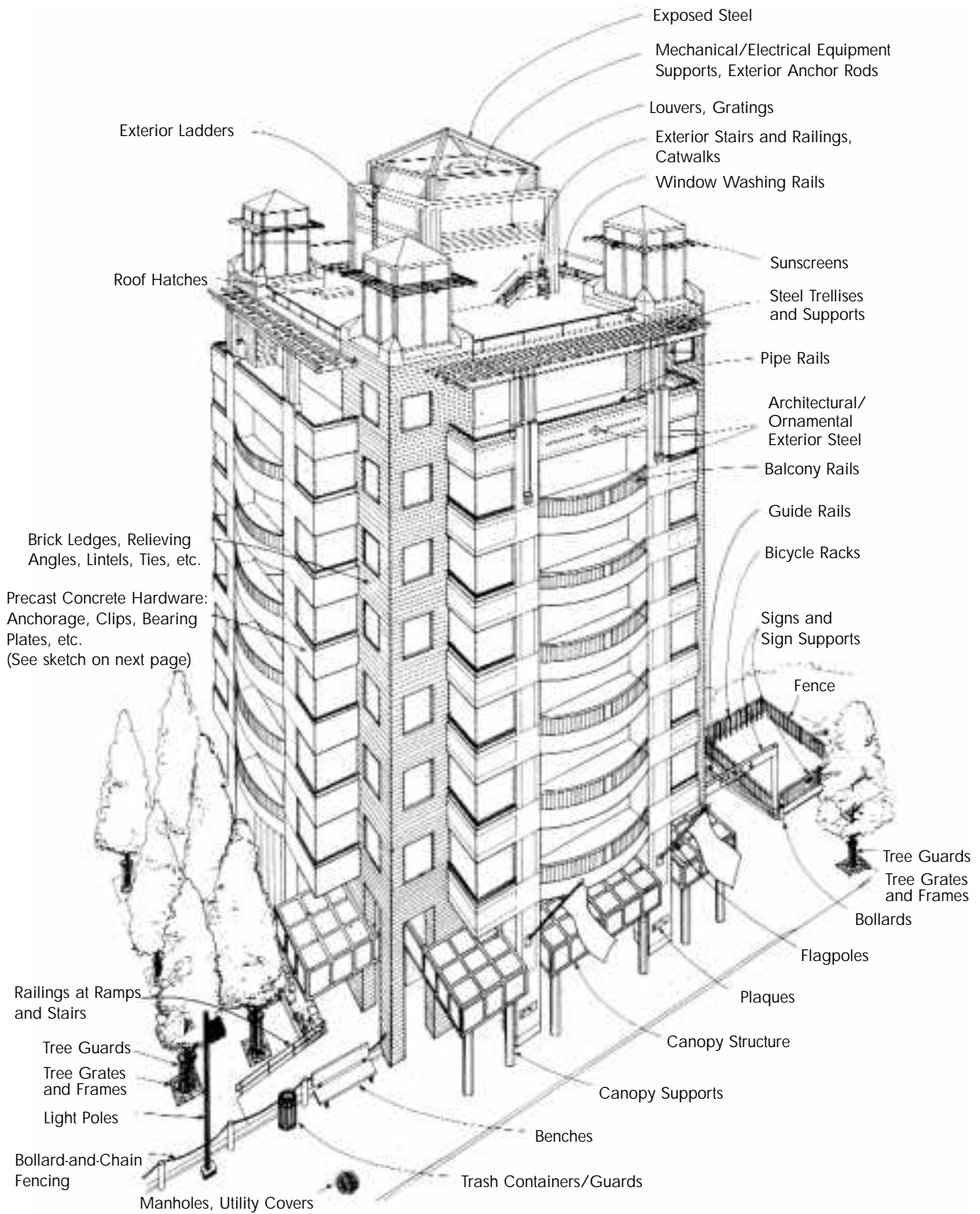
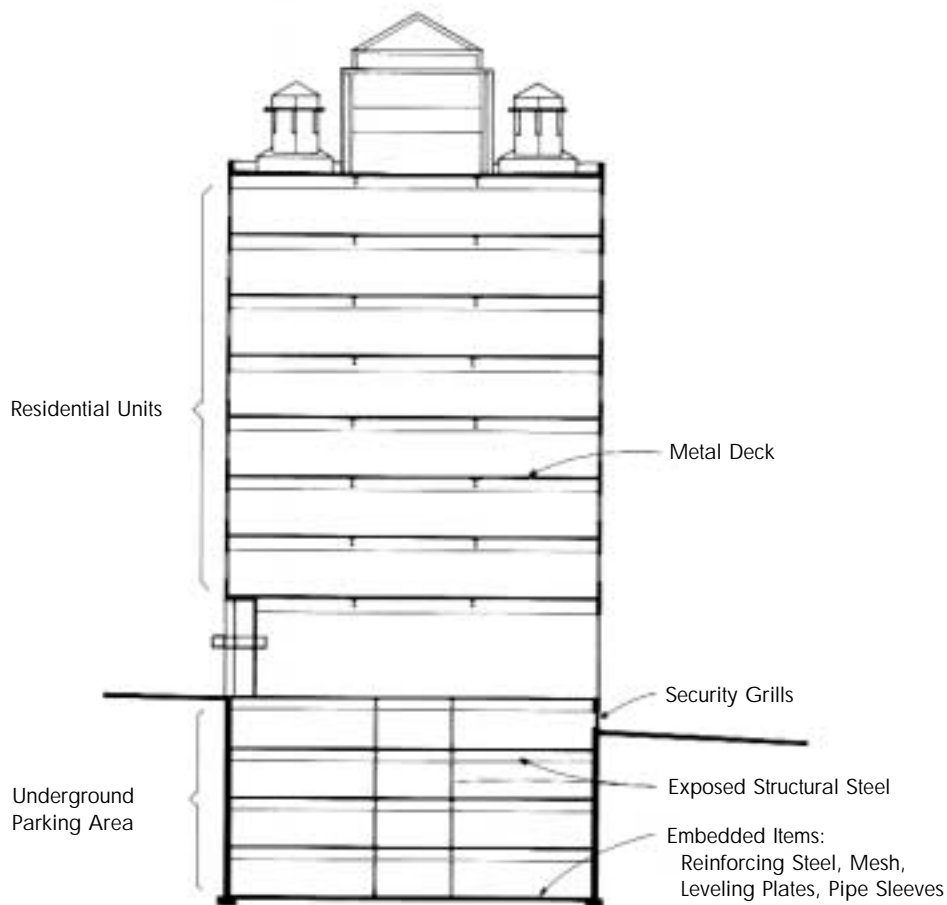
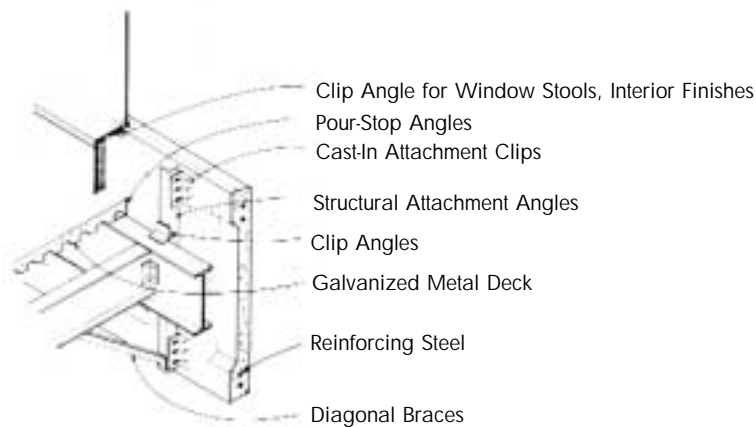


Figure 24. High potential corrosion areas of high-rise buildings



**BUILDING SECTION SHOWING UNDERGROUND PARKING**



**PRECAST CONCRETE ATTACHMENT**

**Figure 24. (Continued)** High potential corrosion areas of high-rise buildings



Project Name \_\_\_\_\_ Date \_\_\_\_\_

**Division 2 - Site Work**

- Railings
- Fence/Gates
- Fence
- Guide Rail Signs/Sign Supports
- Benches
- Light Poles
- Bike Racks
- Trash Containers
- Tree Guards
- Manhole Covers Utility Covers
- Post & Chain Fencing
- Bollards
- Fountain Accessories
- Metal Sculptures Footbridges
- Other

**Division 3 - Concrete**

- Precast Hardware
- Brick Ledges
- Relieving Angles
- Anchor Rods
- Reinforcing Steel
- Mesh/Embedded Items
- Lintels
- Other

**Division 4 - Masonry**

- Anchor Rods
- Lintels
- Relieving Angles
- Brick Ledges
- Other

**Division 5 - Structural/Misc. Steel**

- Window Washing Rails
- Support Steel in Garage
- Railings
- Handicapped Rails
- Fences and Gates
- Fence
- Anchor Rods
- Relieving Angles

- Lintels
- Brick Ledges
- Balcony Rails
- Ladders
- Trash Containers
- Fire Escapes
- Tree Guards
- Catwalks
- Gratings/Hatches Channel and Stringers for Exterior Stairs
- Security Light Poles
- Architectural/Ornamental Steel
- Canopy Supports
- Steel in Atrium Area
- Steel in Laundry Area
- Steel in Swimming Area
- Sunscreens/Trellises
- Flag Poles
- Curb Angles
- Pipe Stanchions
- Other

**Division 15 - Mechanical**

- Exterior Anchor Rods
- Catwalks
- Gratings
- Supporting Steel for Mechanical/HVAC Equipment
- Equipment Screens
- Louvers
- Other

**Division 16 - Electrical**

- Exterior Anchor Rods
- Gratings
- Pipe Support
- Supporting Steel for Mechanical/ HVAC Equipment
- Light Poles
- Other

**Figure 25.** High-rise building design checklist



resin-based paints applied over chlorinated rubber primers are used. It is important to use compatible products (primer, sealer and topcoat). There are a variety of manufactured paint systems that have unique characteristics and are appropriate for specific use with galvanized steel. Specific paint system characteristics, however, are beyond the scope of this guide. Comments here relate only to generic paint systems and are based on overall understanding of industry experience. Contact paint manufacturers for additional information of specific paint applications.

A paint system that is to be used over galvanized steel typically includes pretreatment, primers and topcoats. Pretreatments are commonly used to condition galvanized surfaces for proper paint adhesion. In many cases, a topcoat will not adhere to galvanized steel without a primer. Therefore, a primer coat is a critical component of the system. The primer acts as a tie coat to the galvanized steel, and provides other performance characteristics for the overall system. The topcoat must also resist dulling, fading, chalking, flaking, peeling and blistering in the environment in which the steel must function.

## PAINT SYSTEMS

### Government Standards

Over the past several years, environmental and worker protection regulations have been promulgated that have had a dramatic impact on the way painting can be conducted for both new and existing structural steel.

The 1990 Clean Air Act Amendment requires that volatile organic compound emissions be reduced for industrial maintenance coatings for field applications. The systems included herein have VOC levels up to 3.5 lbs per gallon (0.42 kg/liter).

### Coating Systems

Paint systems used in the U.S. are listed in Table 1. Some of the systems are listed as "Newer Technology." This is because experience with these systems is generally less than ten years, but available information indicates the products to be effective and worth consideration—especially for unique situations. Tables 2a and 2b are an application guide showing the most effective use of the paint systems described in Table 1. These tables offer recommendations for the type of system that will be effective, based on the severity of the environment in which it will be used, and also indicate the systems that can be used to topcoat various types of existing paints.

### Interior Structural Steel

Before an appropriate coatings systems for a specific application is determined, it must first be determined whether or not a coating system is actually required at all. Currently, many architects specify all interior steel that is not covered with spray-applied fire protection to be shop primed, even though the steel will not be exposed to view or subjected to corrosive environments. This specification is usually not appropriate and is generally not in the best interest of the owner.

An examination of a number of buildings that had been in use for more than 50 years indicated no corrosion of any significance whether or not the steel was painted. Some isolated locations of severe corrosion had been found in these buildings, but only at localized spots where water had been allowed to seep in and remain in contact with the steel for long periods of time. Results of this study led the American Institute of Steel Construction to conclude that *structural steel hidden between the exterior cladding of a building and the interior finish need not be painted.*





Appropriate protection of the steel should be determined by the end-use of the building and the exposure of the steel structure. The building's service requirements may determine that little or no protection of the steel is necessary at all. Steel does not rust except when exposed to atmospheres above approximately 70 percent relative humidity. Serious corrosion of steel occurs at normal temperatures only in the presence of both oxygen and water. In dry atmospheres (less than 70 percent relative humidity), non-painted steel can be exposed for extremely long periods of time with no evidence of rusting. If the steel is not painted, a thin transparent film of iron oxide forms on the non-painted steel, actually protecting the steel from further corrosion. Therefore, it is difficult to justify painting all interior steel members as a protective measure for the steel.

**Table 1**

Paint Systems

SYSTEM	PRIMER	INTERMEDIATE COAT	TOPCOAT
1	Inorganic Zinc-Rich Primer	Epoxy	Aliphatic Polyurethane
2	Waterborne Inorganic Zinc-Rich Primer	Acrylic Waterborne	Acrylic Waterborne
3	Polyurethane Organic Zinc-Rich	Polyurethane	Aliphatic Polyurethane
4	Epoxy Organic Zinc-Rich	Epoxy	Aliphatic Polyurethane
5	Epoxy	Epoxy	Aliphatic Polyurethane
6	Polyurethane Aluminum Primer***	Polyurethane	Aliphatic Polyurethane
7	Epoxy Mastic	Epoxy Mastic	Aliphatic Polyurethane
8	Oil and Alkyd*	Oil and Alkyd*	Oil and Alkyd*
9	Acrylic Waterborne**	Acrylic Waterborne**	Acrylic Waterborne**
10	Polyurethane Micaceous Iron Oxide***	Polyurethane Micaceous Iron Oxide***	Aliphatic Polyurethane

**Newer Technology Paint Systems**

11	Polyurethane Organic Zinc-Rich	—	Polyurethane, High Build
12	Polyurethane Organic Zinc-Rich	Polyurethane, water-based	Aliphatic Polyurethane (Water Based)
13	Epoxy Organic Zinc-Rich	Acrylic Waterborne**	Acrylic Waterborne
14	Thermal Sprayed Zinc	—	Acrylic Waterborne
15	Thermal Sprayed Zinc	—	—
16	Low Viscosity, 100% Solids, Epoxy Penetrating Sealer or Polyurethane Penetrating Sealer	Epoxy Mastic or Polyurethane	Acrylic Epoxy or Polyurethane

**Notes**

\* Oil and Alkyd paints include alternate inhibitive pigments to lead such as zinc oxide, barium metaborate, zinc hydroxy phosphate, calcium borosilicate, calcium sulphate and zinc molybdate, which have been tested and are acceptable alternates.

\*\* Acrylic Waterborne paints are available with numerous resin systems and pigmentations.

\*\*\* Polyurethane Aluminum Primer and Polyurethane Micaceous Iron Oxide can be used as a primer on bare steel, or as a penetrating sealer on existing coatings. They should be specifically formulated for whichever use is intended.



It is reasonable to conclude that painting is not mandatory for interior steel framing in low humidity environments, provided the structure remains water tight.

The question then must be asked, why paint interior steel at all? If the steel of a building under construction is exposed to the elements for a normal period of time prior to enclosure, the minimal corrosion which occurs on the unpainted steel would not be considered to be structurally detrimental. The issue then becomes a matter of aesthetics. The appearance of "raw" steel may not be desirable. Customers and building owners usually prefer the appearance of a painted surface to a rusty surface on exposed steel framing.

**Table 2a**

Paint Systems in Table 1 Applicable to Maintenance Painting Involving Spot Repairs and Overcoating

EXISTING PAINT SYSTEM	HIGHLY CORROSIVE* ENVIRONMENT	MILDLY CORROSIVE ENVIRONMENT
Zinc-Rich	3,4,5,7,10 <b>11,12,13,16</b>	3,4,5,7,9,10 <b>11,12,13,16</b>
Oil/Alkyd	6,7,8,9,10 <b>16</b>	6,7,8,9,10 <b>16</b>
Vinyl and Chlorinated Rubber	6,9,10 <b>16 (Polyurethane Penetrating Sealer)</b>	6,9,10 <b>16 (Polyurethane Penetrating Sealer)</b>
Epoxy** or Polyurethane**	5,6,7,10 <b>16</b>	5,6,7,10 <b>16</b>

**Table 2b**

Paint Systems in Table 1 Applicable to New Construction or Maintenance Painting Where Existing Paints are Completely Removed

	HIGHLY CORROSIVE* ENVIRONMENT	MILDLY CORROSIVE ENVIRONMENT
	1,2,3,4,10 <b>11,13,14,15</b>	1,2,3,4,5,6,7,10 <b>11,12,13,14,15,16</b>

*Paint systems reference numbers (see Table 1) shown in bold text are considered "Newer Technology" for either coating unpainted steels or topcoatings over existing paints.*

\* A highly corrosive environment may be a "macro" environment where high ambient chloride levels exist such as immediately over salt water, or a "micro" environment where only a portion of a structure is exposed to such things as manufacturing process chemicals or humidity or both. All other environments are considered at least "mildly" corrosive.

\*\* Roughening of surface may be necessary



There are, however, disadvantages to painting interior steel that is not exposed to view. One disadvantage is the cost. Shop painting can be expensive, particularly if the steel fabrication shop does not have the appropriate painting facilities. For example, not including surface preparation by blasting or other means, a single coat of shop-applied primer can add 3-6 percent to the in-place cost of the structure. Touch-up painting in the field can also add substantial cost to the project, particularly if the required touch-up work is extensive and accessibility to the touch-up area is limited.

Painted surfaces can also be problematic if an item needs to be welded to the painted steel. The paint can contaminate a weld if all of the paint at the weld location is not completely removed.

The architect should determine the most appropriate coatings for the various types of steel members on the project. They should also educate the owner about the appearance and maintenance of various steel finishes specified for the owner's facility. The owner also needs to realize that interior coatings are not expected to protect the steel for extended periods of time prior to the enclosure of the building. This type of information will lead to greater client satisfaction. If an owner insists on painting interior steel, refer to the painting and cleaning specifications produced by the Society for Protective Coatings (formerly the Steel Structures Painting Council/SSPC) for additional painting and surface preparation information.

## SURFACE PREPARATION

### Clean Surfaces and Performance

*Proper surface preparation is vital to maximize the service life of a coating. In fact, inadequate surface preparation is the biggest single cause of coating failures.* No matter how carefully a coating is formulated and manufactured, how sound the research on which it was based or how sophisticated the technology, the coating will fail prematurely in service if the surface to which it is applied was inadequately prepared. No coating can form a strong bond to a surface if there is contamination under the coating that is weakly bound to the substrate. Peeling coatings, dirt, rust, mill scale, oil, wax, moisture or other foreign materials provide a poor foundation to hold a coating, sometimes even when the contamination is present in such small quantities as to be invisible to the eye. The eventual result will be loss of adhesion.

*Surface preparation must be considered as an integral part of the coating specification.* The coating specification must include the following:

- The generic description of the paint used for each coat
- The surface preparation
- The kind and number of the individual coats of paint and their film thickness

*Specifications must be written for coatings systems that include these items as well as the expected performance properties of the entire system over the life of the protected steel.*

### Specifications

Specifications and pictorial standards for surface preparation have been published by SSPC and are considered to be the supreme reference for the architect and maintenance engineer. The complete specification for the above procedures may be found in Volume 2, "Systems and Specification", of the *Steel Structures Painting Manual*. Pictorial standards for these procedures are also available from this group. Following is a brief description of these specifications.



***Solvent Cleaning (SSPC-SP1).*** Describes a method for removing all visible oil, grease, soil, drawing and cutting compounds, and other soluble contaminants from surfaces.

Solvent cleaning should be used prior to any of the other surface preparation methods for the removal of rust, mill scale or paint. If this is not done, containments such as oil or salt on the surface of rust or paint could be driven into the substrate and would be difficult, if not impossible, to remove.

***Hand Tool Cleaning (SSPC-SP2).*** Describes a method of preparing surfaces by using non-power tools. Before hand tool cleaning, remove all visible oil, grease and soluble welding residues, and salts by the method outlined in SSPC-SP1. Hand tool cleaning is intended to remove all loose mill scale, rust and paint. It is not intended that this process remove tight mill scale, rust and paint. Materials are considered adherent if they cannot be lifted with a dull putty knife. Examples of hand tools are a wire brush and sandpaper.

***Power Tool Cleaning (SSPC-SP3).*** A specification that describes a method of preparing steel surfaces by using power-assisted hand tools. Before power tool cleaning, remove all visible oil, grease and soluble welding residue, and salts by the method outlined in SSPC-SP1. Power tool cleaning is intended to remove all loose mill scale, rust, paint and other foreign matter. It is not intended that this process remove adherent mill scale, rust and paint. Materials are considered adherent if they cannot be lifted with a dull putty knife. Examples of power tools include a rotary abrader, grinder and needle gun. Vacuum power tools should be specified to comply with OSHA regulations regarding emissions.

***White Metal Blast Cleaning (SSPC-SP5).*** Describes a method of cleaning surfaces by using abrasives. Before white metal cleaning, remove all visible oil, grease and soluble welding residue, and salts by the method outlined in SSPC-SP1. When white metal cleaned surfaces are viewed without magnification, they shall be completely free of all visible oil, grease, dirt, dust, mill scale, rust, paint, oxides, corrosion products and other foreign matter. Blast media can be metal shot or mineral grit.

***Commercial Blast Cleaning (SSPC-SP6).*** Describes a method for cleaning surfaces by using abrasives. Before blast cleaning, visible deposits of oil or grease shall be removed by the method outlined in SSPC-SP1. When commercial blast cleaned surfaces are viewed without magnification, they shall be free of all visible oil, grease, dirt, dust, mill scale, rust, paint, oxides, corrosion products and other foreign matter, except for staining as described in Section 2.2 of that specification.

***Brush-Off Blast Cleaning (SSPC-SP7).*** Describes a method of cleaning surfaces by using abrasives. Before blast cleaning, visible deposits of oil or grease shall be removed by the method outlined in SSPC-SP1. When brush-off cleaned surfaces are viewed without magnification, they shall be free of all visible oil, grease, dirt and dust. Tightly adherent mill scale, rust and paint may remain on the surfaces. Materials are considered tightly adherent if they cannot be lifted with a dull putty knife.

***Pickling (SSPC-SP8).*** Describes a method of cleaning steel surfaces by means of chemical action, electrolysis or both. Before pickling, visible deposits of oil or grease shall be removed by the method outlined in SSPC-SP1. When pickled surfaces are viewed without magnification, they shall be free of visible mill scale or rust.

***Near-White Metal Blast Cleaning (SSPC-SP10).*** Describes a method of cleaning surfaces by using abrasives. Before blast cleaning, visible deposits of oil or grease shall be removed by the method outlined in SSPC-SP1. When near-white cleaned surfaces are viewed without magnification, they shall be free of visible oil, grease, dirt, dust, mill scale, rust, paint, oxides, corrosion products and other foreign matter, except for staining as described in Section 2.2 of that specification.

***Power Tool Cleaning (SSPC-SP11).*** Describes a method of cleaning surfaces to bare metal and retaining or producing a surface profile by using power tools. This method differs from SSPC-SP3 (Power Tool Cleaning) in that



SSPC-SP3 requires only the removal of loosely adherent material and does not require the production or retention of a surface profile. Before power tool cleaning, visible deposits of oil or grease shall be removed by the method outlined in SSPC-SP1. When SSPC-SP11 power tool cleaned surfaces are viewed without magnification, they shall be free of oil, grease, dirt, rust, mill scale, rust, paint, oxide and corrosion products and other foreign matter. Slight residues of rust and paint may be left in the lower portion of pits if the original surface is pitted.

## OTHER SUBSTRATES

In addition to steel, there are other surfaces that must be coated for aesthetic, safety or corrosion inhibition purposes. These surfaces must also be prepared properly for coating.

**Concrete.** Concrete should be coated for the protection from moisture penetration and the resulting physical damage of spalling. There are several factors to consider when preparing concrete to receive coating.

1. Laitance is a thin layer of fine particles on the surface of fresh concrete caused by the upward migration of water during the mixing and finishing process. Because this layer has poor adherence to the main body of concrete, it must be removed before coating. Abrasive blasting or acid etching can accomplish this. Failure to remove this laitance layer prior to coating is the biggest cause of failure on new concrete.
2. Efflorescence is the deposition of salts on the concrete surface caused by moisture release during curing or moisture migration through the concrete as it ages. These alkaline deposits act much like concrete laitance and must be removed.
3. Form oil is applied to concrete forms as a release agent prior to pouring the concrete, to ensure the easy removal of the forms after curing. Some form oils are transferred to the concrete surface as a contaminant and must be removed by detergent and water washing before acid etching or abrasive blasting.
4. Concrete hardeners are sometimes used to modify the strength and permeability of concrete. They tend to migrate to the surface and cannot be acid etched. They must be removed with abrasive blasting.

The surface of the concrete is usually treated to promote adhesion of the coating system. Either physical abrading or chemical cleaning methods are used. Physical abrading can be done with, for example, sandpaper or a power-abrading machine. Chemical cleaning can be done with various chemicals such as trisodium phosphate or muriatic (hydrochloric) acid. After treatment, the surface must be dry and free from grit.

**Cast Iron.** Cast iron is a porous material that is likely to absorb moisture or other liquids with which it comes in contact. These liquids must be removed prior to surface preparation and painting. The requirements of the paint system control the degree of blast cleaning.

**Zinc.** Zinc surfaces (galvanized or metal sprayed) should first receive a surface cleaning according to SSPC-SP1 (Solvent Cleaning). The surface should then be etched with materials like mild phosphoric acid or ammonium hydroxide to give a rough surface profile suitable for the specified coating. If the zinc is allowed to weather naturally, the zinc oxide will provide a profile suitable for many coatings.

*Alkyd- or ester-based coatings* must not be applied directly to zinc surfaces. Zinc oxide is an amphoteric material that is capable of acting as either an acid or base. The zinc oxide can destroy the integrity of an ester/alkyd coating by saponifying the ester link producing a zinc soap. The result can be deterioration of film properties and loss of adhesion of the coating to the zinc surface.

**Copper and Brass.** Copper and brass must be abrasive blasted according to SSPC-SP 7 (Brush-Off Blast Cleaning) in order to remove corrosion products and provide a surface profile.



## USE OF PROTECTIVE COATINGS

### Shop Painting Bare Steel

When constructing a new structure, an owner now benefits from a number of environmentally friendly coatings with greatly extended service life. It is expected that coating technology will continue to evolve, allowing the development of coating systems that are even longer lasting and more economical.

The use of metallic zinc pigmentation in today's coatings effectively eliminates under-cutting corrosion and sub-film corrosion through galvanic action. Abrasive blast removal of mill scale in the fabrication shop improves long-term adhesion and helps the original coating tolerate maintenance overcoating without costly surface preparation. With an intermediate coat and topcoat applied, the first required maintenance should occur after approximately 25 years of service. At that time, with spot cleaning, spot priming and the addition of another topcoat (approximately 2-3 mils), you could expect another 15-20 years of service life. At the end of that period, the same process would be repeated with the same anticipated results.

A shop may be either a permanent painting shop (which may be part of a steel fabricator's plant), a separate painting shop, or a temporary shop constructed at or near the building site to repaint the steel. A covered shelter does not necessarily constitute a "shop."

The shop-applied coating may include an initial coat or multiple coats as specified by the owner, or, if acceptable to the owner, as selected by the contractor.

New steel used as a construction item is the easiest to protect from corrosion because it probably has not been contaminated with salts that act as electrolytes for the corrosion cells. Because the salts may not be present, it will be easier to achieve the degree of surface preparation needed to protect steel. Older steel (and specifically corroded steel) may have soluble salts imbedded in the corroded pits and intergranular surfaces. Though the salts may be of a soluble type, they are difficult to remove even with the most rigorous cleaning procedures and tend to shorten the service life of coating systems when compared to the life of the same systems on new steel.

Mill scale is a hard, smooth, blue-black layer of iron oxide ( $\text{Fe}_2\text{O}_3$ ) that forms on steel during the hot-rolling process. Mill scale is very inert. When intact, it forms a very efficient barrier to protect steel from corrosion. Unfortunately it has a different coefficient of expansion than steel and is very brittle. Because of this, it cracks and chips. The remaining mill scale then becomes cathodic with respect to steel, forming very efficient corrosion cells. The result is that mill scale must be removed before painting.

Red rust, a form of mixed iron oxides, is a surface contaminant familiar to everyone. It varies in color from light red to dark brown and may be loose and powdery or hard and granular. Red rust provides a weak foundation for paint, contributes to the formation of corrosion cells, and contributes to the destruction of coatings. In the case of light superficial rust, there are surface-tolerant primers that can be used to provide future protection of the steel. For example, steel that has been prepared and cleaned in the fabrication shop may develop superficial rust on the jobsite prior to the building being enclosed may be adequately protected by such primers.

Generally, all new structural steel is specified for Near-White Metal Blast Clean, SSPC-SP10 or Commercial Blast Cleaning, SSPC-SP6.

### Requirements for Preparation of Bare Metal

Surface preparation is the most critical procedure for successful performance of a coating system. Surface preparation consists of cleaning the bare steel or previously coated surface. It includes establishing an appropriate pro-



file of bare steel and/or an acceptable surface condition of the previously coated surface. Cleaning and surface profile are both critical to the performance of the paint system.

Cleaning of the surface includes removal of all soluble salts, oils, grease, dirt, dust and any other contaminants, by whatever means necessary, that will adversely affect the adhesion of the paint coat to the surface. Ensuring that recontamination does not occur, such as from airborne dusts, is also critical to a successful recoating project.

When blast cleaning is used to prepare the surface, the compressed air used to propel the abrasive shall be tested periodically to ensure it is free from oil and moisture and sufficient volume and pressure to clean the surface in a productive manner to the required profile.

For inorganic zinc prime coatings, surfaces shall be cleaned to a level as obtained by SSPC-SP10 for new construction. For other primer coats, the surface preferably should be cleaned to SSPC-SP6 or SSPC-SP3 may be acceptable.

## Preparation Methods and Specifications

**Power washing.** Consists of blasting the steel with water at a pressure of 800 psi to 5,000 psi with the nozzle not more than 12 in. from the surface. If residue containing hazardous substances is removed during the washing process, the water will have to be strained to remove the contaminants or disposed of as hazardous waste.

**Abrasives.** Any abrasives used shall be free of oil, moisture, hazardous substances (i.e., lead, chromium, mercury, etc.) and corrosive constituents (i.e., chlorides, sulfates, salts, etc.). Non-steel abrasives shall be in accordance with SSPC-AB1, *Specifications for Mineral and Slag Abrasives*. Abrasives with "free" silica contents in excess of one percent should not be used.

As surface profile is critical to paint system performance, it must be controlled at the time it is produced, i.e., when the blasting work is conducted. This can be accomplished by controlling the range of particle size and shape in the abrasive used for blasting. The SSPC has published a reference guide, *Visual Standard for Abrasive Blast Cleaned Steel SSPC-Vis1-89*.

When using automated recycling blasting equipment with steel shot or grit, it is important to consider that a working mix is developed through use, then maintained by addition of suitable quantities of steel abrasive of the correct size range. This mixture of sizes is commonly called the work mix or operating mix. It is important to emphasize that this is indeed a mixture of a range of particle sizes, shape and hardness that is necessary to produce the correct profile. Larger particle sizes are suitable for removing heavy build-ups of mill scale or rust. Smaller size ranges increase productivity of removal of corrosion products through an increased number of impacts. When using abrasives, the "right mix" can be obtained through consultation with the supplier of the abrasive.

Steel shot/steel grit abrasives, with maximum recycling, are strongly recommended when blasting steel. When recycled, the abrasives shall be visibly cleaned to meet SSPC Recyclable Abrasive Specification XRAX-92P.

**Surface profiles.** Profiles of steel surfaces shall be obtained using abrasive or equipment meeting the requirements herein. When repairs to previously applied coatings are required, the proper surface condition of the repair area shall be obtained by power tool cleaning, spot blasting or by other acceptable means. Surface profile is measured as the difference between the average depths of the bottom of the peaks to the average tops of the highest peaks created by the blasting.

The profile height is dependant upon the size, type and hardness of the abrasive, the particle velocity, and angle of impact and hardness of the surface. Surface profile provides the "tooth" needed for adhesion and long-term



durability of coating systems. Too great a profile can result in inadequate coverage of the peaks by the first coat of paint, leading to premature rust-through of the coating. For most coatings up to about 8 mils (200 microns) thickness (note: all references to paint film thickness are based on dry film thickness [DFT] measurements), a surface profile of 1 mil (25 microns) minimum to 3 mils (76 microns) maximum is adequate for new surfaces. For maintenance painting, actual profiles may be substantially greater due to pitting caused by corrosion. Selection of a coating system must consider the actual profile present. The user is advised to follow the recommendations of the coating manufacturer for a particular product.

Surface profile measurements shall be determined in accordance with ASTM Specification D4417, *Standard Test Methods for Field Measurement of Surface Profile of Blast Cleaned Steel*. Methods A, B or C may be used. Method A is a visual comparison between the blasted surface and a standard. Method B entails actual measurement of the depth of profile and determining the arithmetic mean. Method C uses a replica tape and a micrometer and is generally considered the most reliable of the three methods.

**Faying surfaces (new construction).** The contract drawings indicate the surface preparation requirements, Classes A, B or C, for faying surfaces of slip-critical bolted connections. When approved by the owner, the contractor may redesign the connection to provide a different class of contact surface. For coated faying surfaces, the contractor shall supply the owner with a certification that the coating proposed to be used has been tested by an independent laboratory, and meets the slip coefficient requirements used in the design of the connection for the thickness to be applied. Testing shall be in accordance with the "Testing Method to Determine the Slip Coefficient for Coatings Used in Bolted Joints" as adopted by the Research Council on Structural Connections and located in Appendix A of the 2000 Edition of the *Specification for Structural Joints Using ASTM A325 or A490 Bolts*.

**Edge grinding.** The idea of edges of beams being ground to a  $\frac{1}{16}$ -in. radius prior to shop painting is probably rooted in the traditional belief that coatings draw thin on sharp edges due to the forces of surface tension during drying. Reduced thickness would then lead to corrosion failure. This is not true for paints commonly specified today.

Rolled edges, such as with hot-rolled structural shapes, have rarely been shown to require any additional preparation for painting as the rolling process leaves a rounded edge, although it may not be a  $\frac{1}{16}$ -in. radius. Even when edges are sheared or burned, grinding to a  $\frac{1}{16}$ -in. radius is not necessary for paint performance.

Highly pigmented zinc-rich paints do not flow away from the edge and, in addition, provide galvanic throwing power to protect any edges or areas not coated. Also, these materials resist corrosion undercutting. Therefore, the requirement that burned edges always be ground to a minimum  $\frac{1}{16}$ -in. radius is questionable. Edge radiusing requirements in fabrication specifications are not only very expensive, but offer undetectable improvements in corrosion resistance.

Improved specification language should include provisions that reflect the following:

- Sharp edges, such as those created by flame cutting and shearing, shall be broken prior to surface preparation. (Breaking the edge can be accomplished by a single pass of a grinder in order to flatten the edge.)
- Usually the rolled edges of angles, channels, webs, and I-beams are presumed to need no further rounding. (If sharp edges occur, they can be broken by a single pass of a grinder in order to flatten the edge.)
- Machine fillet welds are considered a paintable surface with no further treatment required. Only weld spatter need be removed.

**Surface imperfections.** Another common myth is that surface imperfections such as ridges, slivers, fins or hackles must be ground flush since they also are sharp edges. Such anomalies are surface imperfections on rolled sections and plates. They result when small (usually less than  $\frac{1}{2}$  in.) areas of the steel surface are not bonded to the





surrounding surface and are bent upward during the blast cleaning, usually by a metallic abrasive. It is typically only necessary to cut off the head of the isolated hackles, with no further grinding. An exception could occur if there were extensive hackles in a small area. In such an instance, some further attention may be warranted.

**Re-profiling of blast cleaned surfaces.** Blast cleaned surfaces that are subsequently ground do not need to be re-profiled to achieve effective coating performance. A small study undertaken by the SSPC has shown that steel which has been blast cleaned, ground and recoated performed as well in salt fog tests as steel that had been re-profiled and recoated.

**Maintenance painting.** Maintenance painting can consist of four options:

- Spot painting
- Spot painting and full topcoat
- Total removal and repaint
- Zone painting

Where the surface is contaminated with marine salts or other contaminants, the surface to be coated should be washed or, if necessary, power washed to remove all contaminants before any other cleaning operations are begun.

At the beginning of the surface cleaning preparation stage of the project, the paint applicator shall clean and prepare a minimum two foot by two foot area to demonstrate that the proposed methods will obtain the specified surface preparation requirements. This area shall be preserved for reference purposes during the surface preparation stage for the remainder of the project.

**Spot painting.** Where only spot painting of corroded areas is specified, all areas of loose paint shall be removed and the bare steel cleaned to the condition specified or required by the manufacturer and equivalent to SSPC-SP1, Solvent Cleaning, SP6 for abrasive blast cleaning, SP2 for hand tool cleaning, SP3 for conventional power tool cleaning, and/or SP11 for special power tool cleaning. Primers requiring a bare metal profile may be cleaned by abrasive blast cleaning SSPC-SP6 or by needle guns and rotary peening tools to SSPC-SP11. Care must be exercised when spot blasting to avoid damaging the intact coating around the blasted areas. This may require use of low-angle blasting and small particle size abrasives. Interfaces (edges) between the existing intact coating and the cleaned area may be feathered to provide a smooth coating for spot priming. Several coating systems do not require feathering (such as polyurethane moisture-cured systems). The bare steel areas shall have an ideal surface profile of 1 mil (25 microns) to 3 mils (76 microns). However, corroded areas will generally be rougher than this, which must be considered in selection of the paint system to prevent early rust-through at the profile peaks. Surface preparation procedures may need to be modified to prevent early rust breakthrough. Paint that is to remain in place around the corroded areas shall be thoroughly cleaned by washing, and roughened, if necessary, by sandpaper or power tools to ensure adhesion of the new paint. The surface of each coat to receive a subsequent coating shall be clean, dry and prepared in accordance with the manufacturer's recommendations.

**Spot painting and total topcoating.** Damaged or corroded areas of the existing coating shall be prepared in accordance with that for spot painting. Roughening of the entire surface may be necessary to achieve proper adhesion. The surface shall be thoroughly washed to remove all contaminants that will adversely affect paint adhesion. As a minimum, the manufacturer's recommendations should be followed.

**Zone painting.** Intact coatings in zones of the structure specified to be painted shall be prepared in accordance with the above procedures and manufacturer's recommendations. Deteriorated areas shall be prepared in accordance with spot painting and total topcoating.



**Recleaning.** Prepared surface shall be coated before any visible rusting occurs and, preferable, within 24 hours after preparation. The occurrence of rusting or contamination from any source will require the recleaning of the surface.

## EVALUATION OF EXISTING COATING FOR OVERCOATING

Overcoating is defined as the process of applying a surface tolerant coating to a minimally prepared surface and existing layer of lead-containing coating. It is not implied that lead particles are neutralized, totally surrounded by or otherwise rendered harmless.

### Overcoat Paint Process

The overcoat painting approach calls for thorough cleaning, using a power water wash, of all exterior structural steel or interior steel when conditions permit. This removes dirt and some embedded chlorides in the surface. In isolated areas of corrosion and/or paint breakdown, loose rust and old coatings are removed by a combination of SSPC-SP2, SP3 or SP11 surface preparation. Project plans must provide for containment and disposal of all generated waste and debris in compliance with applicable environmental regulations. Also, initial air monitoring may be necessary to determine the emission levels of lead and other airborne particulates.

Overcoating eliminates open air blasting so pollution containment and waste disposal costs are reduced. In addition, non-corroded lead-containing paints are left intact after water blasting. This reduces surface preparation costs and allows for these paints to continue providing protection.

During the overcoating process, exposed steel surfaces are spot primed followed by a spot/full intermediate and full topcoat.

### Coating Evaluation

The most important factor in determining if a structure is a candidate for overcoating is to determine the condition of the existing coating system. This evaluation is conducted to assess the condition of the coating and the base metal at representative areas of the structure.

The following factors must be evaluated:

- Approximate percentage of rusted areas
- Character of rust area: light, moderate or severe corrosion
- Compatibility of the existing coating system/systems (test patch areas)
- Condition of steel under the coating (Does mill scale exist?)
- Adhesion of existing coating to the steel
- Adhesion between layers of the coating system
- Determination of paint type and dry film thickness (DFT) of coating. In the case of aluminum-pigmented alkyds, it must be determined whether existing coating, to be painted over, contains leafing or non-leafing aluminum pigments. It may be difficult to develop proper adhesion between leafing pigmented paints and the new coating system.
- Serviceability or expected remaining life of coating and/or ability of the coating to be repaired

**Degree of corrosion.** The determination of the existing condition should be made based on rating the percentage of the surface that is deteriorated (requiring mechanical preparation). The procedures contained in ASTM



D610, *Standard Method for Evaluating Degree of Rusting on Painted Steel Surfaces*, can be used as a guide for a visual assessment of the condition of the surface. If more than 15-20 percent of the total surface is visually corroded, total removal of the existing coating is recommended. This is because the work requirements for preparation of an area of this extent will not be significantly different than for total removal, and the likelihood of obtaining a longer lasting system is greater.

**Adhesion testing of existing coating.** In addition to determining the degree of corrosion, the adhesion of the remainder of the existing coatings to the steel substrate (or between coatings of the existing system) must be determined in accordance with ASTM standard methods. Two test areas representative of the other apparently "intact" coating conditions on the structure should be selected with at least five measurements for every 10,000 sq. ft of painted surface.

If 20 percent of the test areas exhibit condition 3A (jagged removal along incisions up to  $\frac{1}{16}$ -in. on either side) or worse, or a combination of visually corroded conditions and lack of adhesion of 20 percent or more is present, complete removal and recoating is recommended.

## COATING TEST METHODS AND PROCEDURES

The following test methods may be used to evaluate the coating:

### Method 1: Adhesion Testing of Coating to the Steel

The adhesion test may consist of one or more of the following:

1. *SSPC Steel Structures Painting Manual*, Vol. 1, Chapter 2, pp. 204, Pen knife subjective coating adhesion evaluation.
2. ASTM D4541: *Standard method for pull-off strength of coatings using portable adhesion testers*. Test for adhesion of organic coatings. Elcometer adhesion test. Instrumentation testing of the tensile adhesion to the substrate. The inspector determines location and frequency of testing.
3. ASTM D3359: *Standard methods for measuring adhesion by tape test*.

Method A: X-cut Tape Test

Method B: Cross-cut Tape Test

Shear Adhesion Test, measuring adhesion by tape test. Location and frequency of testing is determined by the inspector.

### Method 2: Coating Cohesion and Adhesion Test

Evaluation of coating cohesion and adhesion between coats is accomplished as outlined in Method 1.

### Method 3: Substrate Examination and Evaluation

The test methods are as described in the *Steel Structures Painting Manual*.

1. Vol. 1, Chapter 6, pp.201-202, Tooke gage examination through a 50X internal microscope.
2. Vol. 1, Chapter 6, pp.200. Coating inspection requirements specify use of a minimum 30X power pocket-sized microscope to examine the coating field evaluations.



## Method 4: Dry Film Thickness Testing

The gages that may be employed include:

1. SSPC-PA 2 (Type 1 gages), SSPC Method for Measurement of Dry Film Thickness with Magnetic Gages; *Steel Structures Painting Manual*, Vol. 1, Chapter 6, pp.198-200.
2. SSPC-PA 2 (Type 2 gages), SSPC fixed probe or magnetic flux gages; *Steel Structures Painting Manual*, Vol. 1, Chapter 6, pp.201-202.

## Method 5: Coatings Cure Evaluation

ASTM D1640, *Test Methods for Drying, Curing, or Film Formation of Organic Coatings*, is specified as a recommended field method. Field evaluation of coating cure is generally difficult because there are no universally reliable field tests for such purposes. Solvent rub tests, sandpaper tests and microscopic examinations can be utilized in field testing. If field testing results are inconclusive, coating samples can be taken for extensive laboratory analysis.

## Compatibility of Overcoating System

Prior to selection of materials to overcoat existing coatings, the recommendations of the manufacturers of proposed overcoatings should be solicited. Paints that will cause "lifting" of the existing coating must not be allowed. The compatibility testing of the competitive materials shall be conducted in accordance with ASTM D5064, *Standard Practice for Conducting a Patch Test to Assess Coating Compatibility*, and the following (if different systems are present on different parts of the structure, each system must be tested):

A 12-in. diameter section in the middle of the test area shall have the existing coating removed to bare steel (SSPC-SP 11). The edges of the bared area are to be feathered using power tools. This area shall be primed with the selected paint(s) to determine if the primer lifts the edges off the existing paints.

Apply candidate coatings by proposed method of application to the entire test panel area. (The top coat(s) should be applied to the primed area in accordance with the manufacturer's recommendations.)

Inspect surface after the coating is fully cured (7 days or 2 weeks at 77° Fahrenheit [25°C] and 50 percent relative humidity) for signs of lifting, wrinkling, cracking or other film defects. If time permits. The evaluation period should be extended beyond exposure to the first "deep freeze" to ensure compatibility of the topcoat.

Only coatings exhibiting no peeling or removal (Scale 5A of ASTM D3359) will be allowed.

Degradation—Because existing paint systems may degrade rather rapidly, the tests specified above should be conducted no more than 180 days prior to the beginning of work to ensure that the decision on scope of work (e.g., spot painting versus total removal) is still valid.

Table 3 is a listing of known incompatibilities. This information is the result of actual experiences of bridge owners and should be used as a beginning point in determining system selection when topcoating existing steel.

## SURFACE PREPARATION FOR OVERCOATING SYSTEMS

### Method A: High-Pressure Water Wash

High-pressure water wash can be used to remove dirt and contaminants from existing sound paint surfaces and corroded areas. There is no SSPC specification reference.

**Table 3**

Coating Incompatibility

EXISTING PAINT TO BE COATED	KNOWN INCOMPATIBLE COATINGS	SYMPTOM OF INCOMPATIBILITY
Zinc	Alkyds	Blisters or Delaminates
Oil/Alkyd	Solvent Based Vinyls; Epoxies	Softening, Lifting or Shriveling
Vinyl	Epoxies	Softens or Dissolves Coating

*Note: with the proper formulations, even the above incompatibilities may be overcome.*

All exposed areas of existing steel members are cleaned by high-pressure water to remove chalking, dirt, dust, oil or other deleterious material, so that new paint will adhere to the surface.

There are several schools of thought regarding water pressure. One calls for hydrant pressures of 80-150 psi with large volumes of water. Another requires higher pressures (500-5,000 psi) and less water. The source and types of contaminant and degree of cleanliness will dictate the specification. Also, a non-sudsing, biodegradable detergent may be added to the water to optimize the cleaning operation. However, a rinse operation must follow and various environmental regulations may apply. In general, the purpose of the water wash is to remove loose chalk, paint, rust and dirt prior to the more extensive final surface preparation necessary to the painting operation. Slight chalking may remain as evidenced by rubbing a hand over the existing coating surface.

### Method B: Hand and Power Tool Cleaning

Another method of surface cleaning is Solvent (SSPC-SP1), Hand Tool (SSPC-SP2), Power Tool (SSPC-SP3), and Power Tool Cleaning to Bare Metal Cleaning (SSPC-SP11). All exposed areas of existing steel members (the entire exposed steel structure) are cleaned by approved methods, in accordance with SSPC-SP1, to remove dirt, dust, oil film, or other deleterious material, so that new paint will adhere to the surface. Solvent cleaning may be supplemented by scrubbing with water and mild detergent. Small areas of the structure that show pinhole corrosion, stone damage from traffic or minor scratches are cleaned in accordance with SSPC-SP2, SSPC-SP3 or SSPC-SP11.

Smaller surface areas where the topcoats are peeling or are badly deteriorated are scraped and cleaned by these methods. It is not the intent that large surfaces of corroded metal be prepared by SP2 or SP3 cleaning. Small containment areas that utilize abrasive blasting may be more economical.

In recognition of the economic advantages of overcoating the Federal Highway Administration (FHWA) has been testing the coatings described in Table 4. The on-going test program has been underway for several years, with some results available from FHWA.

### QUALITY ASSURANCE

The goal of the contract is to ensure that a durable paint system, applied in accordance with all the local and national regulations and specifications included herein, is obtained. To achieve this there are responsibilities that the owner, paint manufacturer and contractor must meet. The owner must ensure that contract documents adequately cover the regulatory requirements that the bidders will be asked to cover by their proposal. The owner must also ensure the paint system(s) specified is compatible with existing coatings, if applicable, and the system(s) is proper for the site environment in which it will be located.

**Table 4**

FHWA Test Program: Coating Systems for Minimally Prepared Surfaces

SYSTEM NO.	GENERIC COATING TYPE
1	Waterborne Acrylic (3 Coats)
2	Moisture-Cured Urethane (3 Coats)
3	Epoxy/Aliphatic Urethane
4	Surface Sealer Epoxy/Urethane/Urethane
5	Surface Sealer Urethane/Urethane/Urethane
6	Low VOC Alkyd Primer (2 Coats) Low VOC Silicone Alkyd Topcoat Waterborne Acrylic (3 Coats)
7	Surface Sealer Epoxy/Urethane/Urethane

The contractor is responsible for properly preparing the surface, supplying only acceptable materials and trained workers, supplying properly maintained equipment whether the paint is applied in a shop or the field, and full compliance with the regulatory requirements contained in the contract documents. The paint manufacturer is responsible to supply only the level of quality of materials that meet the contract requirements, including adequate instructions to the contractor and owner of the environmental and application requirements to safely obtain a long-lasting coating.

## EVALUATION OF PERFORMANCE REQUIREMENTS FOR COATING SYSTEMS

The key to selecting paint is to know the performance criteria. For maintenance paint, whether painting the walls of a home or the I-beams of a bridge, there are test methods available whose results can guide in the selection of the paint.

Performance data are available from paint suppliers. A comparison of the different types of paint performance, the cost and the years of service will lead to the best economical decision.

During paint development, performance is measured on paint that is applied under standard conditions. For example, laboratory conditions are held closely around 77° Fahrenheit and 50 percent relative humidity. In addition, surface preparation of the substrate, film thickness, spray conditions, etc. can be very carefully controlled. This leads to very reproducible results and the possibilities of good comparisons between generic types of paint and even between formulations within a type of paint.

Paint is seldom applied in the field under the same carefully controlled conditions used during laboratory cure and testing. This means that field performance may not duplicate exactly laboratory performance. Although the same performance trends seen in the laboratory between generic types of paint and formulations of the same type usually are seen in the field, most researchers will admit that it is very difficult to predict field life expectancies from laboratory data.

There are several ways in which performance information can be gathered:

- Case histories
- Outdoor panel exposures
- Accelerated laboratory tests



In assessing performance, case history documentation for structures in a similar environment is probably the best method for approving a coating system. However, after waiting for five years to determine field performance, it is not unusual to find that paint raw materials have changed or that paint formulations have been improved with state-of-the-art technology. When this is the case, other methods of assessing performance are needed. Four of these methods are described below.

#### **Field and laboratory testing procedures used to judge the performance characteristics of paints:**

1. ***Field application and exposure.*** Paint is applied to test panels and dried in the environment for which the paint is designed. The panels remain in the environment for the duration of the test.
2. ***Lab application with field exposure.*** Paint is applied to test panels and dried under standard laboratory conditions. The panels then are placed in the field in the actual environment where the paint is to be used. The panels remain in this environment for the duration of the test.
3. ***Lab application with test fence exposure.*** Paint is applied to test panels and dried under standard laboratory conditions. The panels then are placed on a test fence in an environment that simulates one where the paint will be used. The panels remain on the test fence for the duration of the test.
4. ***Lab application and testing.*** Paint is applied to test panels and dried under standard laboratory conditions. The panels then are tested under accelerated conditions in a test cabinet that accelerates the deterioration of the paint and substrate.

Paint manufacturers, as well as third-party organizations such as universities, state and federal agencies and technical organizations, run a variety of performance tests to characterize their paints. For example, paint is tested to determine how it:

- Resists corrosive attack to the substrate
- Resists chalking, checking, cracking and loss of gloss and color
- Resists solvents and chemicals
- Resists abrasion from traffic or wind-driven debris

The next sections describe how two performance requirements—substrate protection from corrosion and weathering resistance of the topcoats—are used to judge the suitability of different paints.

## **PROTECTING SUBSTRATES FROM CORROSION**

### **Corrosive Environments**

Steel structures may be exposed to a variety of corrosive elements:

- Water, moisture and humidity
- Salt-laden air and rain
- Chemicals from the atmosphere, splashes or spills
- Graffiti-removal agents



An intact paint film will resist these elements. However, a coating that has defects such as pinholes or has been physically damaged from abrasion or impact will allow these elements to attack and corrode the metal directly. In addition, the effect of ultraviolet degradation from sunlight can deteriorate the paint film, causing chalking and film thickness loss. This can contribute further to the breakdown of the paint film and allow these elements to attack and corrode the steel structures.

The environment in which the structure stands determines how quickly a metal will erode. Environments can be termed benign, mildly corrosive, moderately corrosive or severely corrosive.

- A **benign environment** may result in little or no loss of metal, even when the metal has no protective coating. An example of this might be an arid climate, such as a desert, where there is no moisture or salt.
- A **mild environment** may result in one mil of metal loss per year. An example of this environment may be a Midwest climate where the steel structure might be exposed to rainfall, but probably not to salts or chemicals.
- A **moderate environment** may result in several mils of metal loss per year. An example of this environment may be near a city or a region of light industry. In addition to rain, the steel structure may be exposed to chemical fallout from power and industrial plants.
- A **severe environment** may result in many mils of metal loss per year. An example of this environment might be one in close proximity to seawater, with constant splashing or even immersion, or a heavy industrial area where corrosive acids might be splashed onto the structure.

## Corrosion Performance Testing

The best performance information is data from actual experience and is available from paint manufacturers. However, paint formulations change, so it is often difficult to obtain the original formulations after several years of testing.

The alternative is to evaluate paint systems in a variety of accelerated test methods. Organizations such as the Steel Structures Painting Council (SSPC) and the National Association of Corrosion Engineers (NACE) spend considerable time exposing paint systems in accelerated and field tests and then evaluating correlations between the two.

Next to performance data from an actual application, field test data is the most reliable source of information to judge paint system performance. Test panels routinely are placed on racks on ocean beaches in North Carolina and Texas and on racks in medium and heavy industrial areas in Pittsburgh and Houston to judge performance and estimate service lives.

Paint companies rely on a variety of accelerated test methods to judge the performance of their corrosion-prevention systems. Two pieces of apparatus that have been traditionally used are the Salt Spray Cabinet and the Cleveland Humidity Cabinet™. In recent years, cyclic test methods have been introduced which use the Prohesion Cabinet™ and the Envirotest Cabinet™.

The Salt Spray Cabinet uses a salt solution to create a salt air mist. The panels are exposed continuously to this mist. Tests are run for hundreds to thousands of hours. This test originally was developed to determine corrosion rates for metals and was adopted by paint companies to judge paint performance. Although it is difficult to correlate to field performance, this test is most relied upon of all laboratory paint corrosion tests.

The Cleveland Humidity Cabinet uses condensing moisture (dew) to attack the paint system. Dew is chemically very clean and is a powerful agent for the formation of blisters in poorer performing paint systems. However, correlation to field performance is difficult.





The Prohesion Cabinet is used in a cyclic laboratory test where a salt spray episode is alternated with dry and light episodes. Corrosion mechanisms are similar to those seen in outdoor field exposures. Correlations are being developed between cabinet results and field tests.

The Envirotest Cabinet is another cyclic laboratory test apparatus. In this test, the panels are immersed in salt solutions and subsequently are exposed to dry and light episodes. Correlations also are being developed between these cabinet results and field tests.

### **Test Panels as Substitutes for Structures**

Whichever test method is employed, field or laboratory, paint performance is judged by using steel test panels to simulate the substrates of actual structures. Panels are usually 4 in. × 12 in. and ¼ in. thick, and are made from hot- or cold-rolled steel. Panels can be new or rusted.

The panels are cleaned according to the requirements of the paint system being evaluated—hand tool cleaned, blasted, etc. The coating system is applied and cured per the manufacturer's instructions, sometimes under controlled laboratory conditions and sometimes under actual field conditions. The coating on the panel usually is cut, so that metal is exposed for oxidation. The panel then is exposed according to one of the test procedures.

After the exposure, two areas on the panel are evaluated—the face and the scribe cut. Each region is evaluated for the number and size of blisters. At the scribe cut, the amount of under-cutting is evaluated. In this manner, different coating systems can be compared in order to select the one that meets the requirements for resisting the environment in which your structure stands.

### **Weathering Environments**

The topcoat on a structure not only provides additional coating thickness to help prevent corrosion, it also offers the opportunity to make the structure aesthetically pleasing. The original gloss and color of the coating should not change, so that the structure looks newly painted for the life of the coating system.

The technology of the topcoat must be chosen with the environment in mind. The weathering stresses of a given environment will lead to deterioration of the original gloss and color—the more severe the environment, the faster the appearance will degrade.

Field evaluations have shown that exposure to heat, humidity and sunlight causes coatings to fade, lose their gloss, crack and check. The speed of topcoat deterioration is directly related to the degree of exposure and to the sensitivity of a technology to that exposure.

### **Weathering Performance Testing**

Cans of paint with "polyurethane" on the label do not all have the same weathering performance. Formulation variables, such as the type of polyurethane resin, the type of pigment, the ratio of resin and pigment and the amount of UV-absorbing additives, all determine the weathering properties.

Weathering performance information, like corrosion performance information, is best determined by field testing of laboratory-applied coatings, but the test methods are different. Test fences most often are situated in hot, sometimes humid, regions such as Florida, Arizona or Australia, but it is not unusual to see test fences on paint manufacturing sites in all parts of the country.



Usually field tests are run for a minimum of two years. By this time, a good understanding of weathering life can be estimated. Because developing new paint is a continuous activity, two-year paint data may not be available for newly introduced coatings. If this is the case, one-year data coupled with accelerated laboratory methods may be used.

Two accelerated lab methods are relied on—Weather-O-Meter™ or Q-UV™ weathering apparatus. Both methods use cycles of light and dark, dry and wet. The Weather-O-Meter typically uses a Xenon arc that generates an intense light to accelerate coating deterioration. Six months' exposure in the Weather-O-Meter is similar to two years in Florida. The Q-UV uses a special fluorescent type of light bulb. Three months in an instrument using a Q-UV-A bulb is about the same as two years in Florida.

Accelerated lab methods should only be used in combination with outdoor exposure information—for example, if only one year of Florida data is available. The correlation between accelerated weathering and Florida weathering does not allow for an accurate comparison of different types of paint. It is most suitable for examining minor formulation variations and as a screening tool. This information is a routine part of topcoat performance analysis. Ask for it!

### **Other Types of Performance Environments**

The above sections describe in detail different environments and test methods for evaluating resistance to corrosion and weathering. Other types of environments could be identified. These include, for example, chemical and solvent environments, abrasive environments or immersion—water or soil—environments.

To make things more complicated, one environment often influences paint performance for another environment. For example, if a coating does not resist the effects of the weather, erosion of the coating could lead to premature failure due to corrosion. Similarly, if a coating does not resist chemicals, the coating could dissolve and lead to premature failure of the desired gloss retention.

### **Specifying Paint to Meet Performance Needs**

To achieve the best cost-performance of a paint system, an owner or specifier first must determine the performance required for the structures' environment and then request cost bids based on paint of similar performance.

A low-performance paint, which would be suitable in a benign environment, would not be suitable for use in a more severe environment. For any given performance environment, if a paint has lower-than-required performance, it will fail early.

## **ECONOMICS**

### **Cost of Materials**

Coatings decisions often based on the cost per gallon or liter of paint as supplied. Instead, the cost of the solids portions of the paint should be considered. For example, paint at \$15/gallon with only 50 percent solids is really more expensive than paint which costs \$20/gallon and has 75 percent solids. This is because the real cost must be based on the amount of surface that can be covered. In this example the second paint will cover 50 percent more surface at only 33 percent more cost.



Typically, 10 to 30 percent more material is required than calculated. This additional material is used to wet and fill brushes, roller and spray equipment, is used to fill the profile caused by blast cleaning or is lost in over-spray. The proportional paint loss due to filling application equipment is greatest when small surfaces areas are to be painted and smallest for large jobs. Paint lost due to over-spray is highest when spray painting small diameter pipes, railing and catwalks and is lowest when painting large flat surfaces, such as walls or large tanks.

### **Life Cycle Cost**

The paint raw material cost is only a small portion of the cost attributed to corrosion prevention through coating. A specifier must look at the cost of protection throughout the life of the coating cycle. The coating specifier must consider costs associated with painting such as inspection, surface preparation, the paint, application labor, containment and disposal. Paint costs can vary between 5 and 15 percent of the total cost. Since more expensive coatings systems usually last longer, they lead to lower lifetime costs than do low cost coatings that do not last as long.

### **Transfer Rates**

Another factor that must be considered is the amount of material lost during the application process. For example, application by brush will result in a 4-8 percent loss; by roller, 4-8 percent; by conventional spray, 20-40 percent; or by airless spray, 10-20 percent. In addition, the amount of loss will vary with the size and shape of the surface being coated and the environmental conditions. For example, under adverse conditions of high wind and small surfaces, spray loss can be as high as 50 percent or more.

### **Estimating Paint Requirements**

When the amount of surface to be painted is known, the amount of paint to order can be calculated by taking into account the surface area, the solids of the paint, the dry-film-thickness and the application loss.

## **INSPECTION**

An inspector is a major factor in achieving a successful paint job. The inspector assists the engineer in the writing of the specification, acts as arbitrator with the contractor, oversees surface preparation and paint application and, overall, acts as the quality control expert. After the job the inspector can act as troubleshooter for failing systems. To obtain planned economics and realize the maximum potential of a coating system, it is essential that the system be installed exactly as designed. The employment of a qualified inspector is a means of increasing the probability of a successful application.



## COATING REFERENCES

1. *Guide for Painting Steel Structures*, American Association of State Highway and Transportation Officials, Washington, D. C. (1994).
2. *Steel Structures Painting Manual*, Vol. 1, "Good Painting Practice," Steel Structures Painting Council, Pittsburgh, PA (1989).
3. *Steel Structures Painting Manual*, Vol. 2, "Systems and Specifications," Steel Structures Painting Council, Pittsburgh, PA (1989).
4. *The Manual of Steel Construction (LRFD)*, 3<sup>rd</sup> Ed. 2001, American Institute of Steel Construction, Chicago, IL (2001).
5. *Corrosion Control by Organic Coatings*, National Association of Corrosion Engineers, Houston, TX (1981).
6. *Federation Series on Coating Technology*, edited by The Federation of Society of Paint Technology, Philadelphia, PA (1964-1993).
7. *Myths and Realities of Steel Bridges*, American Institute of Steel Construction and AISC Marketing, Inc., Chicago, IL (1994).
8. *Paint and Protective Coatings*, P. Richard Hergenrother and Dr. Richard Roesler, Miles, Inc. (1994).
9. JPCL, Journal of Protective Coatings and Linings, Clive Hare.
10. *Guide for Painting Steel Structures*, AASHTO Bridge Subcommittee (1994).
11. *Morphology of the Hot-Dip Galvanized Coating*, American Galvanizers Association, Aurora, CO (1996).



## FIRE PROTECTION

Fire protection is a major consideration in the design of most modern buildings. In its simplest terms, the means of fire protection for steel structures involves either of the following:

- Prescriptive methods with pre-approved construction assemblies based upon results from a "standard" American Society for Testing and Materials (ASTM) fire test (ASTM E119)
- Methods based upon fire engineering often referred to as rational fire design

What follows is an explanation of the rationale and practical considerations for both approaches.

## GENERAL FACTORS

Three issues involved in fire protection include *life safety*, *protection of the structure*, and *fire suppression*. The need to fire protect a structure is a matter of compliance with the building codes that specify the number of hours of fire exposure that a building structure must withstand, within specific temperature limits. This is determined by such factors as the building use, occupancy, number of stories, building height, total floor area, area of each floor, and building separation.

Both the building codes and the insurance underwriters determine fire suppression requirements. For example, the building codes specify that high-rise buildings, large shopping malls and large industrial storage buildings be equipped with sprinkler systems. The insurance underwriters prefer that the structure be of noncombustible materials but, beyond that, their main concern is for the building contents whose value may far exceed the value of the structure itself. The requirements of the insurance underwriters for fire suppression devices can affect insurance premiums or whether or not the owner can obtain insurance coverage at all. In addition, the underwriters may provide insurance incentives in the form of reduced premiums for certain fire suppression measures such as modern Early Suppression Fast Response (ESFR) sprinkler systems. These may exceed the building code requirements and in turn, may allow for reductions in the amount of required fire protection on the structure itself or may liberalize building use restrictions.

## Building Codes

Building codes determine the level of fire protection expected. Therefore, a working knowledge of the various building codes is essential. With the exception of some large cities that maintain their own codes, most areas in the United States enforce one of the following national model codes:

- *National Building Code*, published by the Building Officials and Code Administrators International, [www.bocai.org](http://www.bocai.org).
- *Standard Building Code*, published by the Southern Building Code Congress International, [www.sbcci.org](http://www.sbcci.org).
- *Uniform Building Code*, published by the International Conference of Building Officials, [www.icbo.org](http://www.icbo.org).

More recently, in 2000, a coordinated effort by the three model code bodies has resulted in the development of a single national code, the *International Building Code* (also known as IBC 2000). This was done to eliminate differences and inconsistencies among the three current codes and to simplify the task of building design. IBC 2000 acceptance is slowly growing across the country. Also, the reader should be aware that the National Fire Protection Agency is in the process of drafting yet another national model code.

Two building code issues that affect the selection and design of structural systems include the combustibility of the structural materials and the fire resistance of the structural system, as discussed in the next sections.



### Combustibility of the Structural Materials

Fires usually start small and require fuel in order to grow. In fact, most fires either self-extinguish because of a lack of fuel or are quickly extinguished by building occupants or fire suppression systems such as sprinklers. Furthermore, even though most fires involve building contents, in the case of buildings built of combustible materials, the structure itself may represent the greatest potential source of fuel.

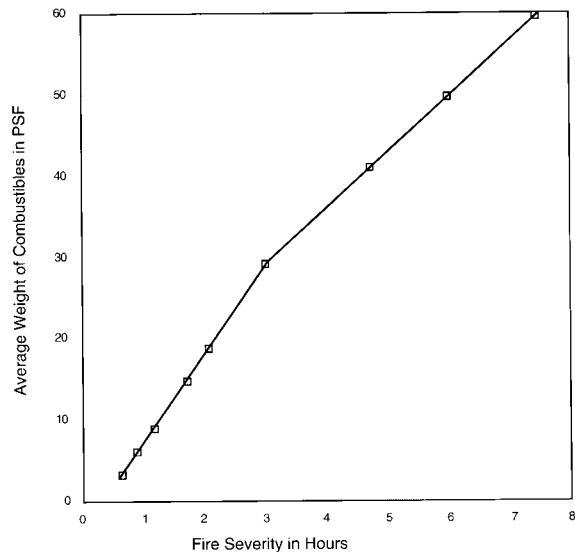
Noncombustible materials such as stone, brick, concrete and steel do not burn and therefore are not a source of fuel. Although the physical properties of non-combustible materials may be adversely affected at elevated temperatures, these materials do not contribute to either the duration or intensity of a fire. Conversely, combustible materials such as wood, paper and plastic do increase the intensity and/or duration of a fire.

Tests conducted by the National Institute for Standards and Technology have indicated that an approximate relationship exists between the amount of available combustible material (fire loading expressed as pounds of wood equivalent per square foot of floor area), and fire severity (expressed as hours of equivalent fire exposure based upon the standard ASTM fire test). This relationship is illustrated in Figure 26. Subsequent field surveys measured the fire loads typically found in buildings with different occupancies and are listed in Table 5 (*Fire Protection Through Modern Building Codes*), produced by the American Iron and Steel Institute.

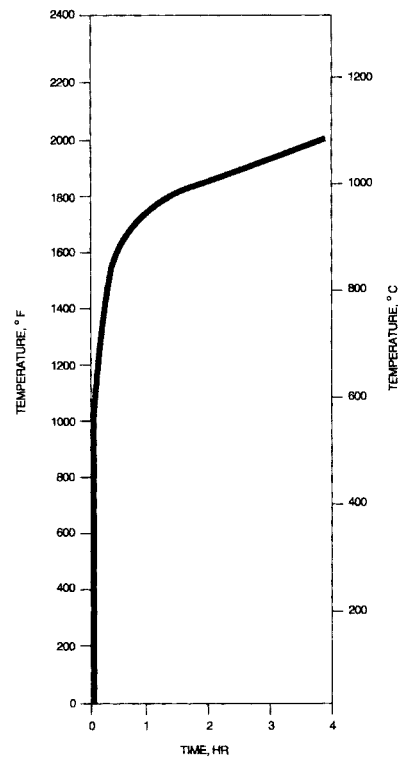
For noncombustible framing there is no assigned fire load. However, for conventional wood framing, a reasonable estimate of fire load for the structure is 7.5 to 10 psf. For heavy timber construction, the corresponding structural fire load might be on the order of 12.5 to 17.5 psf. As a result, building codes generally limit permitted size (allowable height and area) of combustible buildings much more than for noncombustible buildings.

### Fire Resistance of the Structure

In addition to regulating buildings according to the combustibility or noncombustibility of the structure, building codes also specify fire resistance requirements



**Figure 26.** NIST graph illustrating the relationship of fire severity to the average weight of combustibles in a building



**Figure 27.** Graph from ASTM E119 test showing relationship of time to fire resistance temperature requirements

**Table 5**

Typical Occupancy Fire Loads and Fire Severity

<b>OCCUPANCY DESIGNATION</b>	<b>OCCUPANCY FIRE LOAD (psf)</b>	<b>EQUIVALENT FIRE SEVERITY (hours)</b>
Assembly	5 to 10	0 to 1
Business	5 to 10	0 to 1
Educational	5 to 10	0 to 1
Hazardous	Variable	Variable
Industrial		
Low Hazard	0 to 10	0 to 1
Moderate Hazard	10 to 25	1 to 2½
Institutional	5 to 10	0 to 1
Mercantile	10 to 20	1 to 2
Residential	5 to 10	0 to 1
Storage		
Low Hazard	1 to 10	0 to 1
Moderate Hazard	10 to 30	1 to 3

according to building size (height and area) and type of occupancy. Generally, fire resistance is defined as the relative ability of construction assemblies (floors, walls, partitions, beams, girders and columns) to prevent the spread of fire to adjacent spaces and/or to continue to perform structurally when exposed to fire. Fire resistance requirements are generally based upon standard tests in accordance with ASTM E119.

The ASTM E119 test method specifies a "standard" fire exposure that is used to evaluate the fire resistance of construction assemblies (Figure 27). Fire resistance requirements are specified in terms of the time during which an assembly continues to prevent the spread of fire and/or perform structurally when exposed to the "standard" fire. Thus, fire resistance requirements are expressed in periods of time in increments of whole or half hours. The design of the fire resistant buildings is typically accomplished in a very prescriptive fashion by selecting tested construction assemblies that meet specific building code requirements. Listings of fire resistance ratings for tested construction assemblies are available from the following sources:

- *Fire-Resistance Directory*, Underwriters Laboratories (UL), Northbrook, Illinois.
- *Fire-Resistance Ratings*, American Insurance Services Group, New York, New York.
- *Fire-Resistance Design Manual*, Gypsum Association, Washington, D.C.

The term "fireproof" is often used to describe fire-resistant buildings. Some manufacturers use this term to describe fire protection materials. The use of "fireproof" and "fireproofing" is improper because it connotes absolute protection; experience has clearly shown that large-loss fires can occur in fire-resistant buildings. No building is truly fireproof.

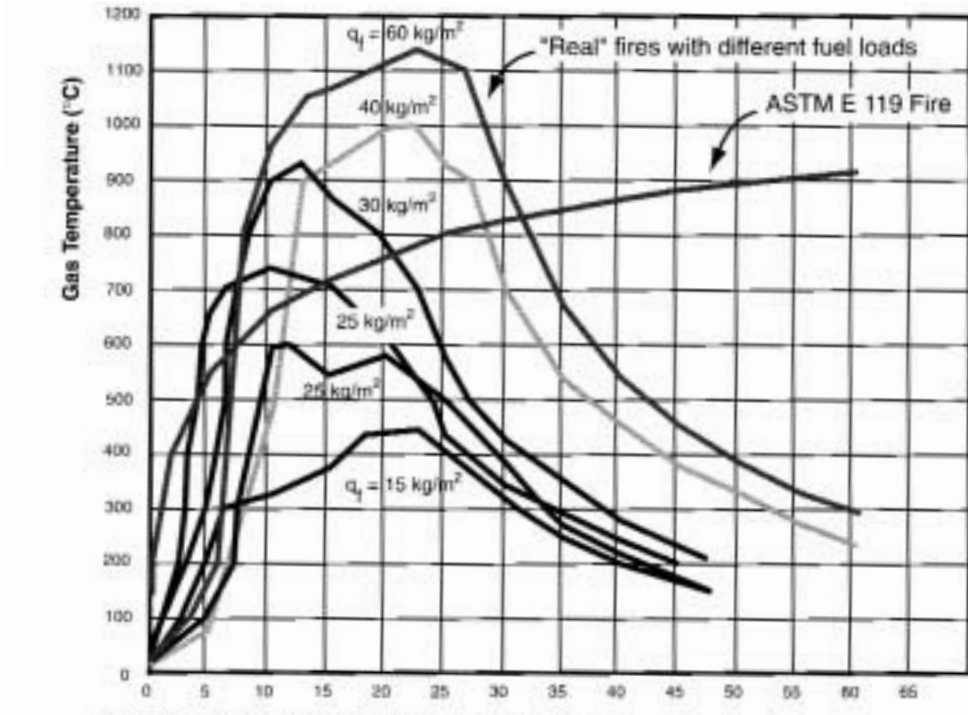


Figure 28. Time/temperature curves for various fire exposures

### Effect of Temperature on Steel

The elevated temperatures developed during standard fire tests adversely affect the properties of virtually all materials, even noncombustible ones such as steel. In general, structural steel retains 60 percent of its ambient temperature yield strength at 1,000° Fahrenheit. During most building fires, temperatures in excess of 1,000° Fahrenheit are developed for relatively brief periods of time. Additionally, the structural elements are generally not loaded to their full design strength. Consequently, even bare steel may have sufficient load carrying capacity to withstand the effects of fire.

The "standard" ASTM fire test is conducted so that temperatures continuously increase, assuming an inexhaustible fire load, and the members are loaded to full design load. Figure 28 shows the time/temperature curves for fires under the standard ASTM test compared with "real" fires with different fire loads. As a result of the "standard" fire tests, when building codes specify fire-resistant construction, fire protection materials are required to "insulate" structural steel elements.

Fire casualty statistics indicate that occupant safety is threatened much more by toxic smoke than structural collapse.

### Temperatures of Fire Exposed Structural Steel Elements

Basic heat transfer principles indicate that the rate of temperature change of a steel beam or column will vary inversely with mass and directly with the surface area through which heat is transferred to the member. Thus, the weight-to-heated-perimeter ratio ( $W/D$ ) of a structural steel member significantly influences the temperature that

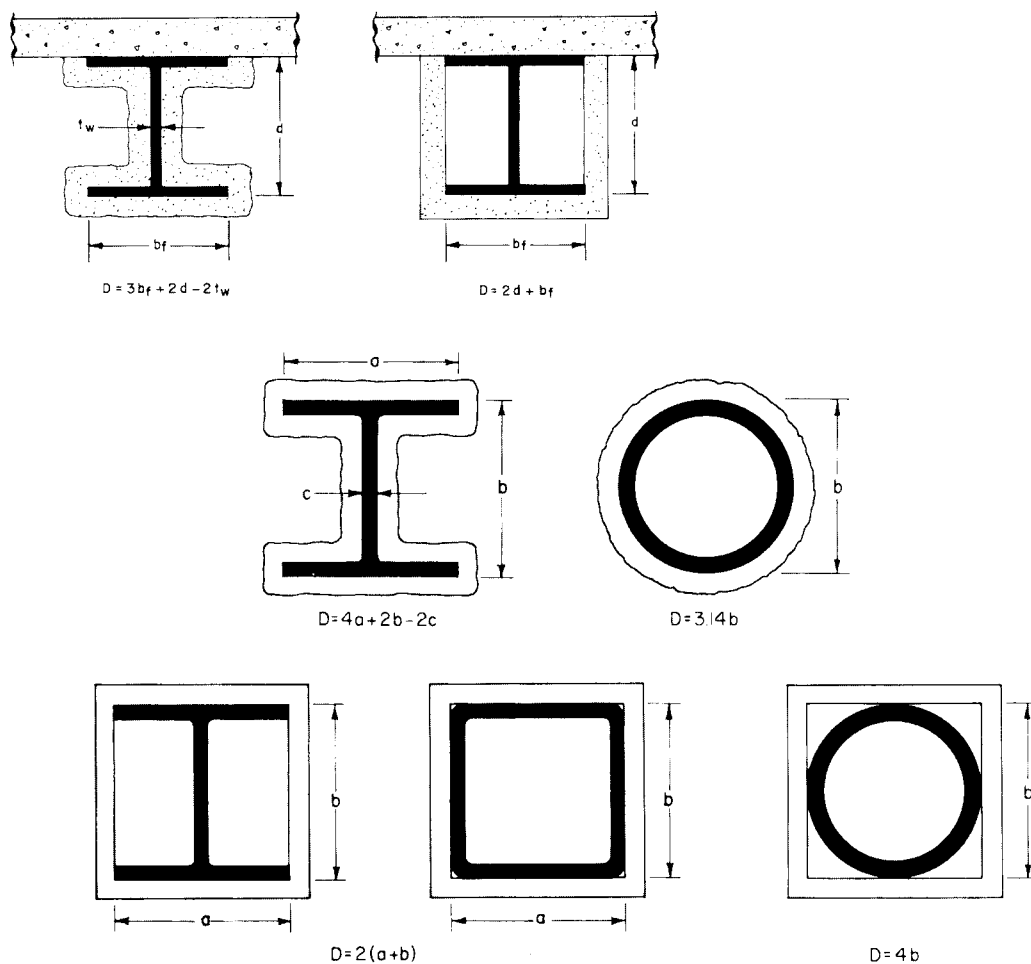




the member will experience when exposed to fire. As used in this expression,  $W$  is the weight per unit length of the member (lbs/ft) and  $D$  is the inside perimeter of the fire protection material (inches). Expressions for calculating  $D$  are illustrated in Figure 29 for both columns and beams with either contour or box protection. In short, the weight-to-heated-perimeter ratio defines the "thermal size" of a structural member.

Since the temperature of a structural steel member is strongly influenced by the  $W/D$  ratio, it follows that the required thickness of fire protection material is also strongly influenced by  $W/D$  ratios. This interrelationship is clearly illustrated in Figure 30 that gives the fire resistance of steel columns protected with different thicknesses of gypsum wallboard as a function of  $W/D$  ratios. Clearly the  $W/D$  ratio is almost as important as the thickness of the fire protection material.  $W/D$  ratios are given in the Materials Section of the Guide.

In recognition of this basic principle, a number of semi-empirical design equations have been developed for determining the thickness of fire protection for structural steel elements as a function of  $W/D$  for specific fire resist-



**Figure 29.** Determination of the heated perimeter of columns and beams. American Iron and Steel Institute; *Designing Fire Protection for Steel Columns, Designing Fire Protection for Steel Beams*



ance ratings. These equations have been incorporated into the UL Fire Resistance Directory, and are described in the following publications available from AISI:

- *Designing Fire Protection For Steel Columns*
- *Designing Fire Protection For Steel Beams*
- *Designing Fire Protection For Steel Trusses*

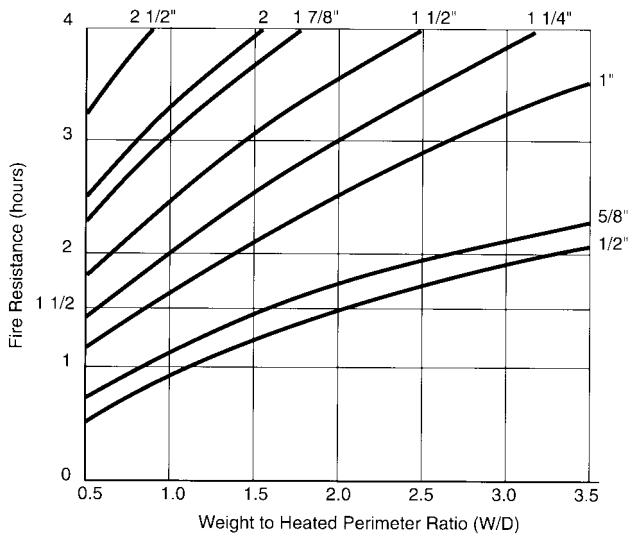
These calculation methods are also incorporated in ASCE/SFPE 29-99 *Standard Calculation Methods for Structural Fire Protection*, published by the American Society of Civil Engineers and in IBC 2000.

### FIRE PROTECTION MATERIALS

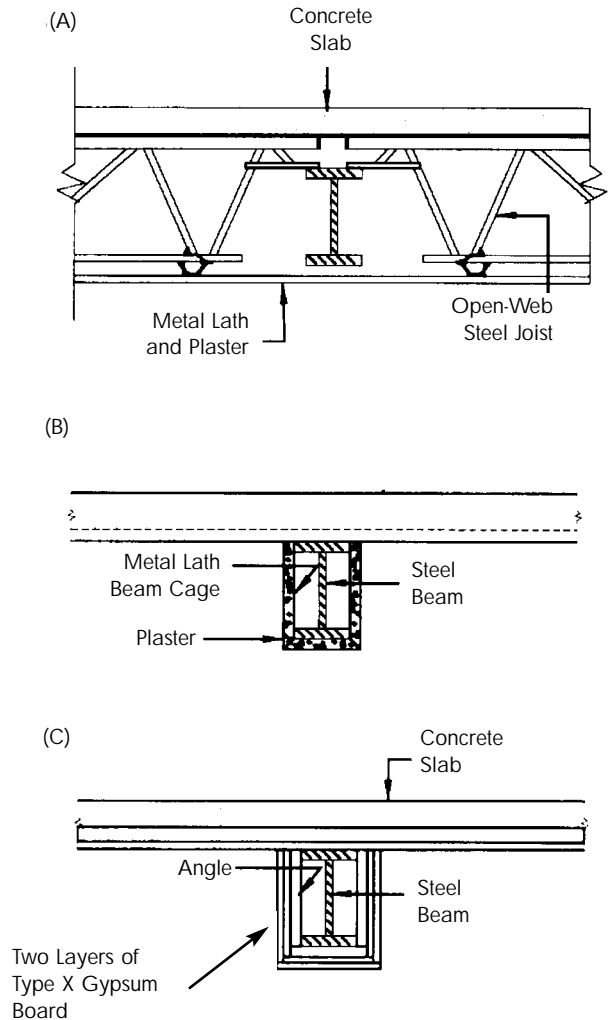
A variety of materials and systems are available to protect (insulate) structural steel. The performance of these materials is evaluated during actual tests. In addition to insulating characteristics, the physical integrity of the materials is very important and care must be taken to ensure that they are installed according to the applicable fire-resistant designs.

#### Gypsum

Gypsum in several forms is widely used as a fire protection material (Figure 31). As a plaster it is applied over metal or gypsum lath. As wallboard it is typically installed



**Figure 30.** Variation in fire resistance of structural steel columns with weight to heated perimeter ratios and various gypsum wallboards. Illustration courtesy of the American Iron and Steel Institute, *Designing Fire Protection for Steel Columns*.



**Figure 31.** Some methods for applying gypsum as fire protection for structural steel: (a) open-web joist with plaster ceiling; (b) beam enclosed in a plaster cage; (c) beam boxed with wallboard. Illustration courtesy of the Gypsum Association, *Fire Resistance Design Manual*.



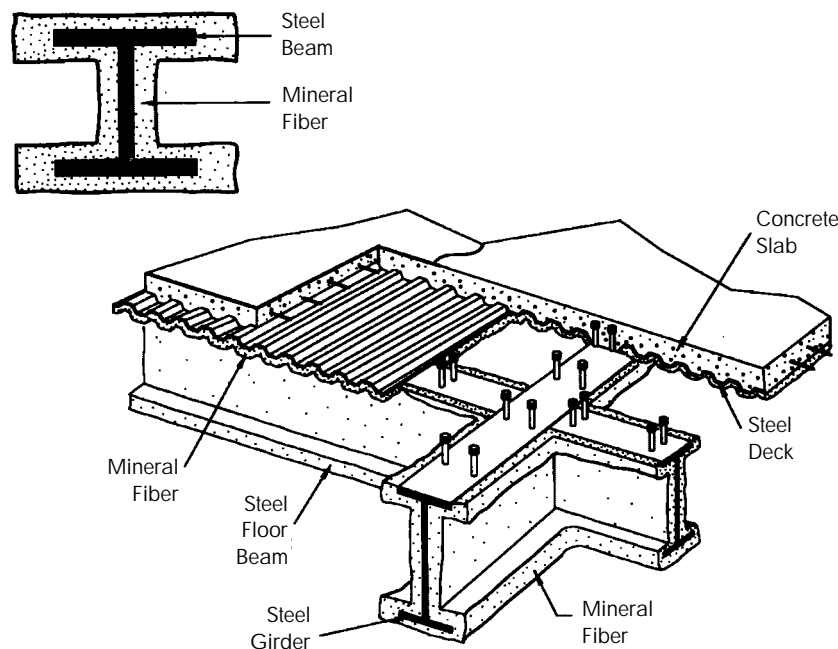
over cold-formed steel framing or furring. Detailed information on using this material for fire protection is available from the Gypsum Association.

The effectiveness of gypsum-based fire protection materials can be increased significantly by the addition of light-weight mineral aggregates such as vermiculite and perlite. For plaster applications, it is important that the mix is properly proportioned, applied in the required thickness, and that the lath is properly installed. In the case of gypsum wallboard, three types are readily available; regular, Type X and proprietary. Type X wallboards have specially formulated cores that provide greater fire resistance than regular wallboard of the same thickness. In addition many manufacturers produce proprietary wallboards with even greater fire-resistance characteristics. It is important to verify that the wallboard used is that specified for a particular design. In addition, special types and spacing of fasteners and furring channels may be required.

### Spray-applied Fire Resistive Material

The most widely used fire protection materials for structural steel are mineral fiber and cementitious materials that are spray-applied directly to the contours of beams, columns, girders and floor/roof decks (see Figure 32). These materials are based upon proprietary formulations and it is imperative that the manufacturers' requirements be followed with regard to mixing and application. Fire-resistant designs as to type and thickness of material are published by UL.

Because these materials are applied directly to the steel, adhesion is an important consideration. Prior to application, the structural steel should be free of dirt, oil and loose scale. Light corrosion will not adversely affect adhesion.



**Figure 32.** Mineral fiber spray applied to beam and girder floor system with steel floor deck supporting a concrete slab. Illustration courtesy of the American Iron and Steel Institute, *Designing Fire Protection for Steel Beams*.



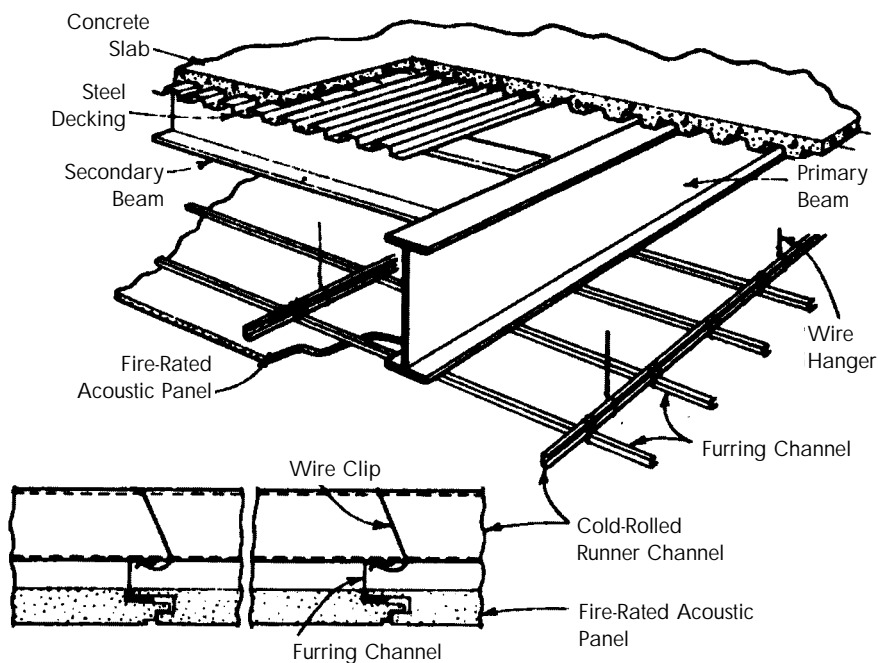
Steel that is to be fire protected with spray-applied material should not be painted or primed unless it is in a corrosive environment, in which case, the bond between primer coat and fire-protective layer must be verified by UL. There are a number of primers that have this certification. In addition, research has found that it is not necessary to paint structural steel when it is fully enclosed between the inside and outside walls of a building, or otherwise protected, such as with spray-applied fire protection materials.

### Suspended Ceiling Systems

A wide variety of proprietary suspended ceiling systems are available for protecting floors, beams and girders (see Figure 33). Fire resistance ratings are published by UL. These systems are specifically designed for fire protection purposes and require the careful integration of ceiling tile, grid and suspension systems. Also, openings for light fixtures, air diffusers and similar accessories must be adequately protected. As a consequence, manufacturer's installation instructions must be closely followed. In case of load transfer trusses and/or girders that support loads from more than one floor, building codes may require individual protection and, as a consequence, suspended ceiling systems may not be permitted for this specific application.

### Concrete and Masonry

In past decades, concrete was the most widely used material for structural steel fire protection. It is not, however, particularly efficient for this purpose due to its relatively high thermal conductivity. As a result, concrete is no longer widely used solely for this purpose. A notable exception is the growing use of composite construction, such as concrete encased steel columns. Concrete and masonry are also sometimes used to protect steel columns for



**Figure 33.** Steel floor system fire protected on the underside by a suspended ceiling. Illustration courtesy of the American Iron and Steel Institute, *Designing Fire Protection for Steel Beams*.



architectural purposes or when substantial resistance to physical damage is required. Design information on fire resistance of steel columns encased in concrete or protected with precast concrete columns covers is available from AISI. Information on using concrete masonry or brick is available from the National Concrete Masonry Association (NCMA), Herndon, VA, and the Brick Institute of America, Reston, VA, respectively.

### Intumescent Coatings

Intumescent coatings are a unique product that can be used to achieve the required fire rating while still architecturally exposing the steel framing. Intumescent coatings are epoxy based paint-like mixtures applied to the primed steel surface, which at elevated temperatures expand to many times their applied thickness. They form an insulating blanket around the steel member protecting the member from further heat. In the past, the time of protection provided by these coatings was fairly limited but with continued improvements, fire ratings of almost three hours are now possible.

Intumescent coatings are not inexpensive, however, costing several times that of common spray-applied systems. The cost of intumescent coatings increases as the required fire rating increases. Therefore, their use is generally limited to exposed steel applications. It is not uncommon to see single members with a combination of systems; spray-applied fibrous systems on hidden portions and intumescent coatings on exposed portions.

### UNDERWRITERS LABORATORIES (UL) ASSEMBLIES

A summary of UL assemblies that are commonly applicable in structural steel building design and construction is provided in Tables 6-10. These tables should be used in conjunction with the criteria and information contained in the latest UL Fire Resistance Directory. However, the inclusion of these assemblies in this Guide should not preclude the use of other UL assemblies or any other rational approach.

The ratings for the assemblies discussed in Tables 6-10 are given for a minimum member size that can be related to other larger member sizes. For *W*-shapes and similar members, this relationship can be made by the ratio of the weight to the heated perimeter ( $W/D$ ). For HSS and steel pipe, the ratio of the area to the heated perimeter ( $A/P$ ) defines the relation.  $W/D$  and  $A/P$  ratios are given in the Materials Section of this Guide.

Note that certain UL assemblies can also be used with members with smaller  $W/D$  and  $A/P$  ratios, provided certain criteria as outlined in the specific UL design are met. Also keep in mind that the equations for columns and braces are generally different because the heated perimeter of a beam differs from that for a column or brace.

Table 6 lists some fire protection systems for roof-ceiling assemblies. Table 7 covers floor-ceiling assemblies. Table 8 lists protection systems for beam-only designs for the roof and Table 9 lists beam-only designs for the floor. Finally, Table 10 shows protection for some common column assemblies. These tables make reference to "restrained" and "unrestrained" ratings, discussed in the next section.

### RESTRAINED AND UNRESTRAINED CONSTRUCTION

In the context of fire resistance, the use of the terms "restrained" or "unrestrained" construction refers to the ability of the structural members and the surrounding construction to resist thermal expansion during elevated temperatures. This is often confused with structural restraint that has to do with the fixity or rigidity of supporting members at their connections. Thermal restraint is an important consideration because most materials tend to expand when heated.

The restrained condition as defined by the codes applies when an assembly (floor system, roof system and its supporting members) is surrounded by construction that is capable of resisting substantial thermal expansion



**Table 6**  
Roof-Ceiling Assemblies

Assembly Rating		Type of Protection System	Roof Insulation Type	Metal Deck Depth (in.)	UL Design Number
Restrained (hr)	Unrestrained (hr)				
1	3/4	Acoustical Ceiling Membrane	Rigid	1-1/2	P254
1	1		Rigid	1-1/2	P214
			Insulating Fill	9/16, 15/16, 1-5/16	P246, P255
				9/16	P261
1, 1-1/2	1, 1-1/2		Rigid	1, 1-1/2	P250
				1-1/2	P230
				1, 1-1/2, 2, 3	P225
			Insulating Fill	15/16, 1-5/16, 1-1/2	P231
1, 1-1/2, 2	1, 1-1/2, 2	Insulating Fill	9/16, 3/4, 1-1/4	P251	
2	2	Rigid	1, 1-1/2	P237	
1-1/2, 2	1-1/2, 2	Plaster w/ Metal Lath Membrane	Rigid	1-1/2	P404
1	1	Gypsum Wallboard Ceiling Membrane	Insulating Fill	1-5/16	P509
2	2		Rigid	1-1/2	P514
3/4, 1, 1-1/2, 2	3/4, 1, 1-1/2, 2	Spray-applied Fire Resistive Material	Rigid	1-1/2, 3	P701
1, 1-1/2, 2	1, 1-1/2, 2		Rigid	1-1/2	P711, P740, P741
				1-1/2, 3	P714, P717, P725, P739, P819
			Insulating Fill	9/16, 15/16, 1-5/16, 1-1/2	P921
1, 1-1/2, 2	1-1/2, 2		Insulating Fill	9/16, 15/16, 1-5/16, 1-1/2	P927
1, 1-1/2, 2, 3	1, 1-1/2, 2		Rigid	1-1/2, 3	P719
1, 1-1/2, 2, 3	1, 1-1/2, 2, 3		Rigid	1-1/2	P723, P733
				1-1/2, 3	P732
2	1-1/2	Rigid	1-1/2	P718	

**NOTES**

- \* The referenced assemblies are some commonly used Underwriters Laboratories (UL) assemblies used for conventional steel framed structures. For additional assemblies the reader should reference the UL Fire Resistance Directory.
- \* For additional design requirements such as beam spacing, concrete strength, density, reinforcing and clear cover, minimum metal deck gage, maximum deck span, shear connector requirements, design stress limitations, etc. see the specific referenced assembly in the UL directory.
- \* For roof designs that incorporate structural concrete slabs, D-series assemblies can be used provided that the roof insulation type, density and the appropriate D-series assembly modifications are in accordance with the UL directory published requirements.
- \* Metal deck depth for some assemblies is shown as a minimum and deeper decks may be substituted. Refer to the specific UL assembly for additional information.



**Table 7**

Floor-Ceiling Assemblies

Assembly Rating		Type of Protection System	Concrete		Metal Deck Depth (in.)	UL Design Number	
Restrained (hr)	Unrestrained (hr)		Min. Thickness above deck flutes (in.)	Type			
1, 1-1/2, 2, 3	1, 1-1/2, 2, 3	Acoustical Ceiling Membrane	based upon required rating	NW or LW	1-1/2, 2, 3	D216	
2, 3	2, 3			NW	1-1/2	D218	
1-1/2, 2	1-1/2, 2	Gypsum Wallboard Ceiling Membrane	2-1/2	NW	1-1/2, 2, 3	D502	
2	1-1/2		2	LW	3, 4-1/2, 6, 7-1/2	D501	
1, 1-1/2, 2, 3	1, 1-1/2, 2, 3	Spray-Applied Fire Resistive Material	2	NW or LW	2, 3	D743	
			2-1/2	NW or LW	9/16, 15/16, 1-5/16	D780	
1-1/2, 2, 3	D759, D832						
1, 1-1/2, 2, 3, 4	1, 1-1/2, 2, 3, 4		2-1/2	NW or LW	1-1/2, 2, 3	D739, D767, D779, D858	
			3-1/4	LW	1-1/2, 2, 3	D782	
2	1, 1-1/2		2-1/2	LW	1-1/2, 2, 3	D752	
2, 3, 4	1, 1-1/2, 2, 3		2-1/2	NW	1-1/2, 1-5/8	D744	
3, 4	1-1/2, 2		3-1/4	LW	1-1/2, 2, 3	D754	
1, 1-1/2, 2, 3	1, 1-1/2, 2, 3		Spray-Applied Fire Resistive Material w/ Unprotected Deck	based upon required rating	NW or LW	1-1/2, 1-5/8, 2, 3	D902
						1-1/2, 2, 3	D916, D925

**NOTES**

\* The referenced assemblies are some commonly used Underwriters Laboratories (UL) assemblies used for conventional steel framed structures. For additional assemblies the reader should reference the UL Fire Resistance Directory.

\* For additional design requirements such as beam spacing, concrete strength, density, reinforcing and clear cover, minimum metal deck gage, maximum deck span, shear connector requirements, design stress limitations, etc. see the specific referenced assembly in the Underwriters Laboratories (UL) directory.



**Table 8**

Beam-Only Designs for Roofs

Assembly Rating		Type of Protection System	Roof Insulation Type	Metal Deck Depth (in.)	UL Design Number
Restrained (hr)	Unrestrained (hr)				
1, 1-1/2, 2, 3	1, 1-1/2, 2, 3	Spray-applied Fire Resistive Material	Rigid	1-1/2	S715, S733
1, 1-1/2, 2, 3, 4	1, 1-1/2, 2, 3, 4		Rigid	1-1/2	S701, S721, S724, S729, S734, S805
			Rigid or Insulating Fill	1-1/2	S735

**NOTES**

- \* The referenced assemblies are some commonly used Underwriters Laboratories (UL) assemblies used for conventional steel framed structures. For additional assemblies the reader should reference the UL Fire Resistance Directory.
- \* For additional design requirements such as beam spacing, concrete strength, density, reinforcing and clear cover, minimum metal deck gage, maximum deck span, shear connector requirements, design stress limitations, etc. see the specific referenced assembly in the Underwriters Laboratories (UL) directory.
- \* Metal deck depth for some assemblies is shown as a minimum and deeper decks may be substituted. Refer to the specific UL assembly for additional information.

**Table 9**

Beam-Only Designs for Floors

Assembly Rating		Type of Protection System	Concrete		Metal Deck Depth (in.)	UL Design Number
Restrained (hr)	Unrestrained (hr)		Min. Thickness Above Deck Flutes (in.)	Type		
2	2	Gypsum Wallboard	2-1/2	NW	1-1/2	N501, N502
3	2		2-1/2	NW	1-1/2	N505
1, 1-1/2, 2, 3, 4	1, 1-1/2, 2, 3, 4	Spray-applied Fire Resistive Material	2-1/2	NW or LW	1-1/2, 2, 3	N706, N734, N739, N823
					1-5/16, 1-1/2, 2, 3	N708, N772, N782

**NOTES**

- \* The referenced assemblies are some commonly used Underwriters Laboratories (UL) assemblies used for conventional steel framed structures. For additional assemblies the reader should reference the UL Fire Resistance Directory.
- \* For additional design requirements such as beam spacing, concrete strength, density, reinforcing and clear cover, minimum metal deck gage, maximum deck span, shear connector requirements, design stress limitations, etc. see the specific referenced assembly in the Underwriters Laboratories (UL) directory.



**Table 10**

## Column Assemblies

Assembly Rating (hr)	Type of Protection	Column Types	UL Design Number
1, 2, 3	Gypsum Wallboard	W, HSS	X528
2		W	X516, X518, X520
3			X509, X510, X513
3/4, 1, 1-1/2, 2, 3, 4	Spray-applied Fire Resistive Material	HSS, Pipe	X771, Y707
1, 1-1/2, 2, 3, 4		W	X772, X829, Y708, Y725
		W, HSS, Pipe	X790, X795
		HSS, Pipe	X827

**NOTES**

\* The referenced assemblies are some commonly used Underwriters Laboratories (UL) assemblies used for conventional steel framed structures. For additional assemblies the reader should reference the UL Fire Resistance Directory.

\* For additional design requirements such as beam spacing, concrete strength, density, reinforcing and clear cover, minimum metal deck gage, maximum deck span, shear connector requirements, design stress limitations, etc. see the specific referenced assembly in the UL directory.

throughout the range of anticipated elevated temperatures. Extensive research in the 1960s showed that restraint improves the fire resistance of many types of common floor system types of common floor systems. For example, when a beam is heated from below, the lower flange tries to expand while the top flange, which is topped with concrete, remains cooler and does not expand at the same rate. When the bottom flange expansion is resisted (restrained) by the surrounding construction (columns, beams on the other side of the columns, the concrete floor slab or roof deck), the resulting forces (compression similar to prestressing) in the beam give it additional capacity to withstand stresses during the fire. This additional capacity to resist the effects of elevated temperatures is reflected in the codes by the fact that "restrained" construction requires significantly less fire protection than "unrestrained."

Table X3.1 of the Appendix to ASTM E119 (see the Partial Extract of the Appendix to ASTM E119 later in this section) defines various forms of bolted, riveted, or welded steel construction as restrained, and has been incorporated into the Standard Building Code (SBCCI) in 1996 as a supplement. This same table continues to be part of the National Building Code (BOCA) by reference. Thus, under these two national model building codes, designers are permitted to treat structural steel framing as restrained per the definition in the table.

Under the Uniform Building Code (ICBO), all assemblies (including steel and concrete) continue to be considered unrestrained unless the engineer of record can substantiate a restrained rating. Until recently there has not been a straightforward method for structural engineers to do this. The result is that steel structures designed according to the Uniform Building Code have usually been classified as "unrestrained" with the resulting higher costs for fire protection.

Recent developments now provide engineers with a ready method for substantiating thermal restraint in their designs. It is available in the following references:

- Ioannides, S.A. and Mehta, S. "Restrained Versus Unrestrained ratings for Steel Structures—A Practical Approach", *Proceedings of the National Steel Construction Conference*, pp. 17.1-17.20, AISC, Chicago, IL, 1997.
- Gewain, Richard and Troup, Emile. "Restrained Fire Resistance Ratings in Structural Steel Buildings" *Engineering Journal*, Vol. 38, No. 2, 2001.

Even though substantiating a restrained rating may require some additional design time on the part of the engineer of record, the costs are usually far outweighed by savings in fire protection.



## Partial Extract of the Appendix to ASTM E119-00a: Standard Test Methods for Fire Tests of Building Construction and Materials

### X3. Guide for Determining Conditions of Restraint for Floor and Roof Assemblies and for Individual Beams

One of the major changes in the new rating criteria was the establishment of restrained and unrestrained ratings. To help determine the appropriate rating to use in a particular building situation, the following Guide is presented. It is Appendix C from the Standard for Fire Tests of Building Construction and Materials, UL263. Paragraphs X3.1 through X3.5 provide general information with respect to the concept of restraint against thermal expansion of building elements as it relates to restrained and unrestrained ratings. Table X3.1 gives examples of restrained and unrestrained conditions for certain common construction types. It should be understood that the information provided in Table X3.1 is to be used as a guide and that the concept of restraint against thermal expansion addressed in paragraphs X3.2 through X3.5 should be carefully considered in assessing the condition of restraint in building structures.

- X3.1 The revisions adopted in 1970 introduced the concept of fire endurance classifications based on two conditions of support: restrained and unrestrained. As a result, specimens can be fire tested in such a manner as to derive these two classifications.
- X3.2 A restrained condition in fire tests, as used in this test method, is one in which expansion at the supports of a load carrying element resulting from the effects of the fire is resisted by forces external to the element. An unrestrained condition is one in which the load carrying element is free to expand and rotate at its supports.
- X3.3 This guide is based on knowledge currently available and recommends that all constructions be classified as either restrained or unrestrained. This classification will enable the architect, engineer, or building official to correlate the fire endurance classification, based on conditions of restraint, with the construction type under consideration. While it has been shown that certain conditions of restraint will improve fire endurance, methodologies for establishing the presence of sufficient restraint in actual constructions have not been standardized.
- X3.4 For the purpose of this guide, restraint in buildings is defined as follows: "Floor and roof assemblies and individual beams in buildings shall be considered restrained when the surrounding or supporting structure is capable of resisting substantial thermal expansion throughout the range of anticipated elevated temperatures. Construction not complying with this definition are assumed to be free to rotate and expand and shall therefore be considered as unrestrained."
- X3.5 This definition requires the exercise of engineering judgment to determine what constitutes restraint to "substantial thermal expansion." Restraint may be provided by the lateral stiffness of supports for floor and roof assemblies and intermediate beams forming part of the assembly. In order to develop restraint, connections must adequately transfer thermal thrusts to such supports. The rigidity of adjoining panels or structures should be considered in assessing the capability of a structure to resist thermal expansion. Continuity, such as that occurring in beams acting continuously over more than two supports, will induce rotational restraint which will usually add to the fire resistance of structural members.
- X3.6 In Table X3.1 only the common types of constructions are listed. Having these examples in mind as well as the philosophy expressed in the preamble, the user should be able to rationalize the less common types of construction.



**Table X3.1**

Construction Classification, Restrained and Unrestrained (ASTM E119-00a)

I. Wall bearing:	
Single span and simply supported end spans of multiple bays: <sup>A</sup>	
(1) Open-web steel joists or steel beams, supporting concrete slab, precast units, or metal decking	unrestrained
(2) Concrete slabs, precast units, or metal decking unrestrained	unrestrained
Interior spans of multiple bays:	
(1) Open-web steel joists, steel beams or metal decking, supporting continuous concrete slab	restrained
(2) Open-web steel joists or steel beams, supporting precast units or metal decking	unrestrained
(3) Cast-in-place concrete slab systems	restrained
(4) Precast concrete where the potential thermal expansion is resisted by adjacent construction <sup>B</sup>	restrained
II. Steel framing:	
(1) Steel beams welded, riveted, or bolted to the framing members	restrained
(2) All types of cast-in-place floor and roof systems (such as beam-and-slabs, flat slabs, pan joists, and waffle slabs) where the floor or roof system is secured to the framing members	restrained
(3) All types of prefabricated floor or roof systems where the structural members are secured to the framing members and the potential thermal expansion of the floor or roof system is resisted by the framing system or the adjoining floor or roof construction <sup>B</sup>	restrained
III. Concrete framing:	
(1) Beams securely fastened to the framing members	restrained
(2) All types of cast-in-place floor or roof systems (such as beam-and-slabs, flat slabs, pan joists, and waffle slabs) where the floor system is cast with the framing members	restrained
(3) Interior and exterior spans of precast systems with cast-in-place joints resulting in restraint equivalent to that which would exist in condition III (1)	restrained
(4) All types of prefabricated floor or roof systems where the structural members are secured to such systems and the potential thermal expansion of the floor or roof systems is resisted by the framing system or the adjoining floor or roof construction <sup>B</sup>	restrained
IV. Wood construction:	
All types	unrestrained
<sup>A</sup> Floor and roof systems can be considered restrained when they are tied into walls with or without tie beams, the walls being designed and detailed to resist thermal thrust from the floor or roof system. <sup>B</sup> For example, resistance to potential thermal expansion is considered to be achieved when: <ol style="list-style-type: none"> <li>(1) Continuous structural concrete topping is used,</li> <li>(2) The space between the ends of precast units or between the ends of units and the vertical face of supports is filled with concrete or mortar, or</li> <li>(3) The space between the ends of precast units and the vertical faces of supports, or between the ends of solid or hollow core slab units does not exceed 0.25 % of the length for normal weight concrete members or 0.1 % of the length for structural lightweight concrete members.</li> </ol>	



## ARCHITECTURALLY EXPOSED STEEL

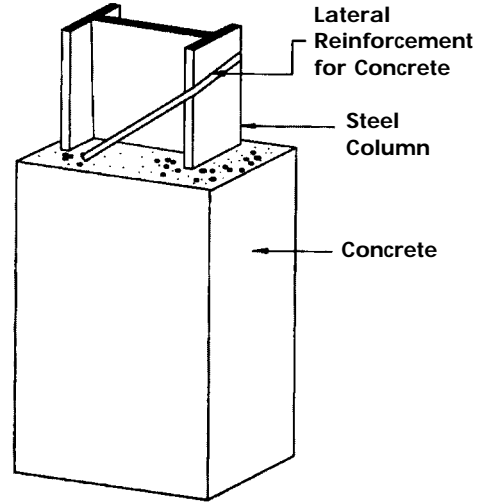
### Exterior Applications

As a result of recent innovations with respect to structural fire protection, the concept of externally exposed structural steel deserves special mention. This allows for direct architectural expression rather than hiding the structure behind a decorative façade. Obviously, building code requirements for fire resistant construction strongly influence the design of architecturally exposed steel. A conventional approach for providing structural fire protection for structurally exposed steel is illustrated in Figure 34. Variations of this approach have been used in many buildings.

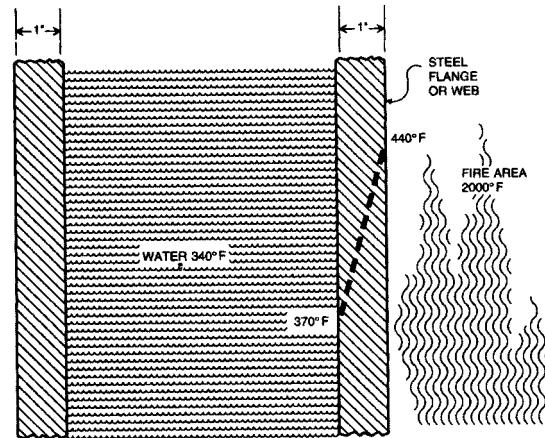
Another technique involves the use of water-filled columns (see Figures 35 and 36). Originally patented in 1884, this method was first used in the United States in the late 1960s for the 64-story US Steel Building in Pittsburgh, PA. Since then the system has been used in a number of buildings both here and in Europe. Although requiring careful and sophisticated engineering, the principles are well established and documented. Virtually any level of fire resistance can be achieved. In general, corrosion inhibitors should be used and, in colder climates, an anti-freeze solution should be used for exterior columns.

Another innovation involves the use of flame-shielded spandrel girder as illustrated in Figure 37. As shown, girder is protected on the interior in a conventional manner. Sheet steel covers are used to provide weather protection for the flanges and to deflect flames away from the exposed exterior web of the girder. This concept was first used for the construction of a 54-story office building in New York City. The design was verified by a wood crib burnout test of a full-scale mock-up of one bay of this building. In addition, a second test was conducted by UL using a gas-fired furnace designed to simulate the spandrel girder configuration. Representative fire, flame and girder temperatures are illustrated in Figure 38.

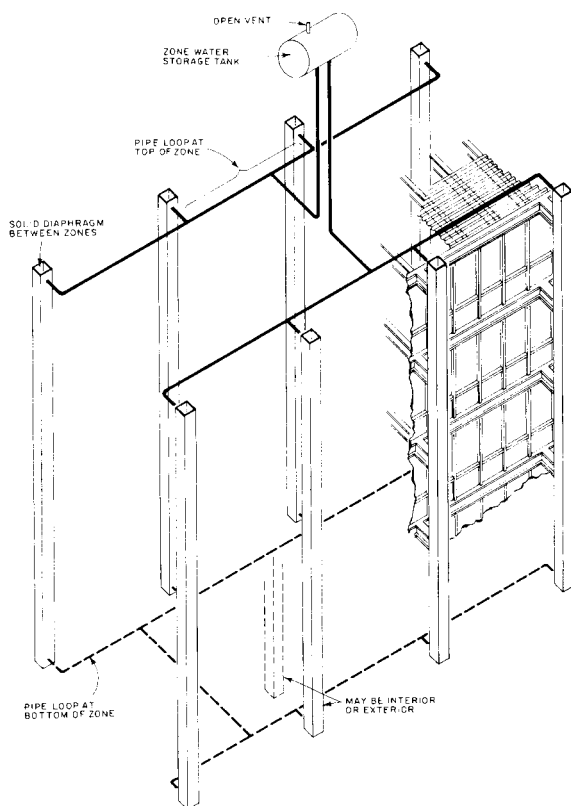
As clearly illustrated by the flame-shielded spandrel girder concept, the "standard" ASTM fire test is not representative of the exposure that would be experienced



**Figure 34.** Fire protected exterior steel column with exposed metal column covers. Illustration courtesy of the American Iron and Steel Institute, *Fire Protection Through Modern Building Codes*.



**Figure 35.** Tubular steel columns filled with water for fire resistance with temperature variation during exposure to fire. Illustration courtesy of the American Iron and Steel Institute, *Fire Protection Through Modern Building Codes*.



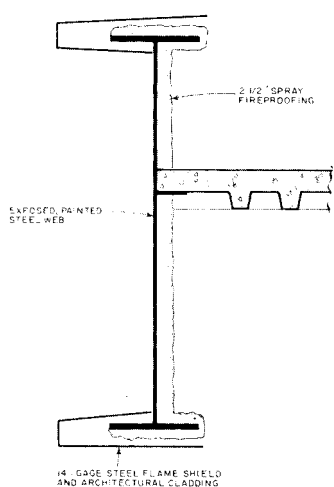
**Figure 36.** Schematic representation of a liquid-filled column fire protection system. Illustration courtesy of U.S. Steel, *Influence of Fire on Exposed Exterior Steel*.

by exterior columns and girders. Research has been conducted worldwide over the last two decades to better define the appropriate exposure for exterior structural elements. A comprehensive design guide is available from AISI (*Design Guide For Fire-Safe Structural Steel*).

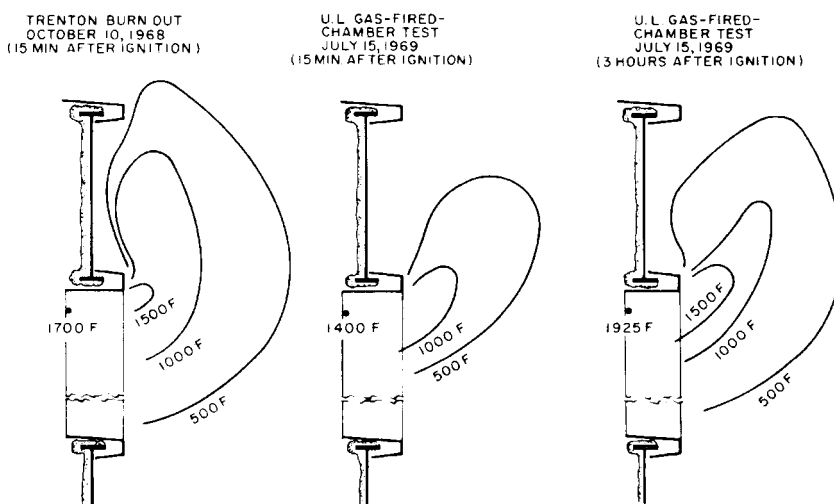
### Interior Applications

Each building code defines conditions (occupancy, area and height) when unprotected bare steel framing is permitted. If fire protection is required by the building code, structural steel exposed in the interior of a building may be protected with intumescent paint as described above. In other cases, a requirement to fire protect may be minimized or eliminated by a fire-engineered solution described in a following section.

Another method for fire protecting architecturally exposed columns for both interior and exterior applications involves encasing the members in a concrete-based insulating material that is then protected by an exterior steel jacket. This method is illustrated in Figures 39 and 40.



**Figure 37.** Fire-resistant flame shielding on spandrel girder. Illustration courtesy of U.S. Steel, *Influence of Fire on Exposed Exterior Steel*.



**Figure 38.** Flame patterns and temperatures during two tests on the load-carrying steel plate girder. Illustration courtesy of U.S. Steel, *Influence of Fire on Exposed Exterior Steel*.



## RATIONAL FIRE DESIGN BASED ON FIRE ENGINEERING

As explained previously, North American building code requirements for structural fire protection are currently prescriptive; they are based on "standard" fire tests that do not accurately replicate actual constructed conditions or realistic fire exposures. In many cases, real fires result in higher temperatures but for much shorter duration than assumed by the current codes. As indicated previously, Figure 27 shows the temperature/time curve for the ASTM E119 standard fire test with a constant fuel source as contrasted with time/temperature curves in realistic fire exposures with different fuel loads. In these realistic tests, one can clearly see the higher initial temperatures that soon taper off as the fuel source is consumed and diminishes.

In addition, the standard ASTM fire test presumes that structural floor members are fully loaded at the time of the fire. In reality, fires occur randomly and design requirements should be probability based. Rarely will members be fully loaded to design capacity at the time of the fire.

All model codes recognize the need to encourage engineered solutions to the fire protection of floor-to-roof systems that modify or bypass the prescriptive measure found in the codes. They all allow for engineered solutions as long as they can be soundly substantiated. In fact some of the solutions mentioned above such as flame-shielded spandrel girders, water filled columns and the effect on the fire resistance ratings for steel of steel mass and shape are a result of code acceptance of steel industry research.

Also, fire engineering methods using computer modeling techniques recognized by the building codes are being used successfully under provisions in the codes that allow for alternate methods. Recently the Uniform Building Code added information on full-scale fire tests to establish and document alternate fire protection measures.

Fire engineering usually combines actual building occupancy, contents and actual anticipated floor-to-ceiling construction with fire suppression measures in order to model the predicted performance of the structure under anticipated fire conditions. This is done in order to establish what is necessary to meet the hourly rating required by the code i.e.; 1-hour, 2-hour or 3-hour etc.

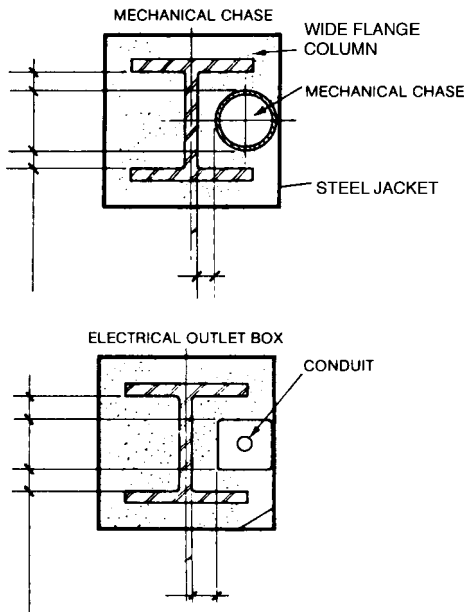


Figure 39. Concrete-based insulating material

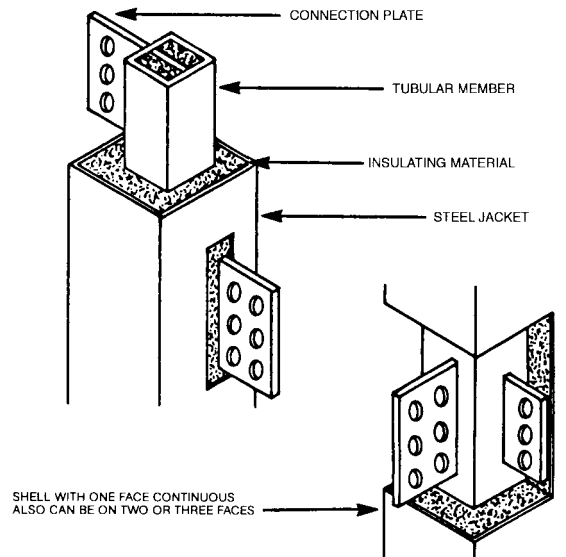


Figure 40. Typical connections in a continuous shell



An engineered solution to the fire protection is often desirable from an aesthetic standpoint such as being able to eliminate fire protection around architecturally exposed columns in the interior of a building. It may be desirable for functional reasons as well. One recent example of fire engineering allowed the elimination of spray-on fire protection on structural steel in a large warehouse storing flammable liquids.

Fire engineering is a specialty normally requiring the additional services of fire protection engineers who understand the performance of steel under elevated temperature conditions. However, for many projects, the incentives in fire protection cost savings are significant and far exceed the additional design costs.







## PART III

# DETERMINING MEMBER SIZES FOR DETAILING

## DETERMINING GIRDER AND BEAM SIZES FOR FLOORS & ROOFS

The architectural planning of any building requires many individual elements. During the pre-schematic design stages, one important aspect to establish is the building height. During these stages of design, preliminary structural information is required. This information will include such things as floor and roof system fire ratings, floor slab depths, roof decking depths, floor beam depths, roof purlin depths, and floor and roof girder depths. Each of these items in combination with the mechanical and electrical system requirements will establish the "ceiling sandwich" and the vertical proportions of the architectural design can be established.

Many times, during the early stage of planning and design, projects will be "designed" with very little participation by the structural team. Without the early involvement by the structural engineer, inaccurate assumptions for member depths and floor/roof systems could be made. Table sets A, B, C and D aid the architectural designer in determining floor and roof system depths. Each set of tables represents a distinct set of floor and roof system parameters. Three different live load conditions for each range of beam and girder spans have been presented. The tables present nominal member depth ranges for beam spans of 20 ft to 40 ft (example: W24 beams have a nominal depth of 24 in.), as well as girder spans from 20 ft to 40 ft. Preliminary beam and girder depths can quickly be determined from the tables for square and rectangular bay sizes ranging from 20 ft × 20 ft to 40 ft × 40 ft. Finally, Table E provides representative span ranges of different structural steel components.

The member sizes indicated in Table sets A-D represent a range of member depths for a particular span. It must be brought to the attention of the user that, as the member depth of any given beam or girder becomes shallower, an increase in member weight will occur. As a general "rule-of-thumb", a 25 percent increase in member weight will occur with each size of depth reduction. As an example, if the reported range is W18 - W24 there will be an approximate 25 percent increase in weight for a W21 member to meet the same design criteria as a W24. A W18 member will have an approximate 25 percent increase in weight if used in place of a W21. Should a W18 member be used in place of a W24, the minimum increase in member weight will be approximately 60 percent ( $1.25 \times 1.25$ ).

As with any design problem there are many solutions. Each project will have a unique set of loading and serviceability parameters. The design information and example have been prepared accurately and are consistent with current structural design practices for several different load cases. The information presented in this publication has been prepared in accordance with recognized engineering principles and is for general information only. While it is believed to be accurate, this information should not be used or relied upon without competent professional examination and verification of its accuracy, suitability, and applicability by a licensed professional engineer, designer, or architect.

### Design Parameters and Limitations

Many specific parameters and limitations go into the design of any structural member. Imposed loadings caused by earthquake, wind, snow, rain, construction methods, etc., vary across the country. Live loads are generally specified in the applicable building codes. Dead loads are much more system-dependent and require special attention in their computation. Specific requirements for serviceability, strength, lateral stability of individual elements, and the lateral resistance of the building all contribute to the design of a safe and efficient building. The



information presented in the tables that follow is intended for use in establishing preliminary floor and roof framing member depths only, without regard to earthquake loading or contributing to lateral resistance of the building.

Beam spans range from 20 ft to 40 ft in 5-ft increments. Girder spans range from 20 ft to 40 ft in 5-ft increments for each of the beam span ranges noted. Therefore, girder depths reported cover 25 different bay sizes for each of three load cases. Dead loads address the self-weight of the floor/roof framing system. Three different slab conditions and one type of roof construction have been considered.

The girder and floor beam sizing tables are based on the following parameters:

- *Load and Resistance Factor Design Specification*, American Institute of Steel Construction, 1999
- Live and dead loads are uniformly distributed over a bay area
- Full live load has been applied to a full bay; no live load reduction has been taken into account
- No analyses have been made for floor vibration/vibration susceptibility
- A construction live load of 20 psf has been applied for composite member design
- Beam and girder depths represent designs for composite as well as non-composite member design
- Live load deflection has been limited to 1/360 of the member span
- Shear connectors for composite type metal decking
- Normal weight concrete unit weight used in the designs is 145 pcf; lightweight concrete unit weight used in the designs is 110 pcf
- Beams and girders have been selected assuming that cambering will be considered by the structural engineer of record for the placement of "level" floors
- Connection designs have not been considered
- 50 ksi steel yield strength and 3000 psi concrete strength
- Actual depths vary from the nominal depths tabulated. For actual member depths, refer to the properties tables found in the Materials Section of this Guide.

### Selection Example for Girder and Floor Beam Sizing Tables

#### Known Design Criteria:

- Dead load includes system self weight (slab + steel)
- Superimposed dead load = 25 psf (partitions + MEP)
- Loads are uniformly distributed over bay area



- Live load = 100 psf
- Dead load = 25 psf (partitions + MEP)
- Self weight considered on the table formulation
- 4¼ in. lightweight concrete topping
- 2 in. metal decking (composite)
- 50 ksi yield strength
- Floor system requiring a 3-hour fire rating (floor assembly, unprotected metal deck)
- Bay size 30 ft x 35 ft (girder span x beam span)

**Solution:***Beam depth selection:*

Enter Table C, Beam Sizes, second row for 100 psf live loading.

Under Beam Span: B1 (ft), fourth column for a 35 ft beam span. Read the range of the member sizes to be W21-W24. This indicates that the nominal beam depth could be as shallow as 21 in. for the W21 beam or as deep as 24 in. for the W24 beam.

*Girder depth selection:*

Enter Table C35, Girder Sizes/Beam Span 35 ft, second row for 100 psf live loading.

Under Girder Span: G1 (ft), third column for a 30 ft girder span. Read the range of the member sizes to be W24-W30. This indicates that the nominal girder depth could be as shallow as 24 in. for the W24 girder or as deep as 30 in. for the W30 girder. An intermediate nominal depth of 27 in. for a W27 could also be selected.

**Summary:**

35 ft beam span: W21-W24 (note that actual depths will vary).

30 ft girder span: W24-W30 (note that actual depths will vary).

Member cambers may be required (consult a structural engineer for specifics).



**Tables A to A40**

- Dead load includes system self weight (slab + steel)
- Superimposed dead load = 25 psf (partitions + MEP)
- Loads are uniformly distributed over bay area
- 3¼ in. lightweight concrete topping
- 2 in. composite metal decking
- 50 ksi steel yield
- 3 ksi concrete strength
- 2-hour fire rating

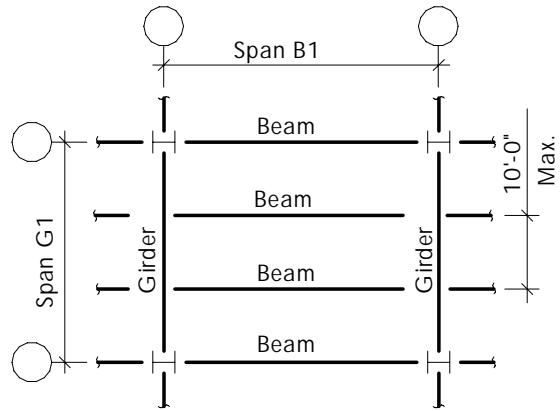


Table A Beam Sizes						
Live Load, psf	Beam Span: B1 (ft)					Classification
	20	25	30	35	40	
50	W10-W16	W14-W16	W16-W21	W18-W21	W21-W27	Office
100	W12-W16	W14-W18	W16-W24	W18-W24	W21-W27	Assembly
150	W14-W18	W18-W21	W18-W24	W21-W27	W24-W30	Storage

Table A20 Girder Sizes						Beam Span 20 feet
Live Load, psf	Girder Span: G1 (ft)					Classification
	20	25	30	35	40	
50	W16-W18	W18-W21	W21-W24	W24-W27	W24-W27	Office
100	W18-W21	W21-W24	W24-W27	W24-W30	W27-W30	Assembly
150	W21-W24	W21-W24	W24-W27	W24-W30	W30-W33	Storage



<b>Table A25</b> Girder Sizes						<b>Beam Span</b> <b>25 feet</b>
Live Load, psf	Girder Span: G1 (ft)					Classification
	20	25	30	35	40	
50	W16-W18	W16-W18	W18-W24	W21-W27	W24-W30	Office
100	W18-W21	W21-W24	W21-W27	W24-W30	W27-W33	Assembly
150	W21-W24	W21-W24	W24-W27	W30-W33	W30-W33	Storage

<b>Table A30</b> Girder Sizes						<b>Beam Span</b> <b>30 feet</b>
Live Load, psf	Girder Span: G1 (ft)					Classification
	20	25	30	35	40	
50	W16-W21	W18-W21	W18-W24	W24-W30	W27-W30	Office
100	W18-W21	W21-W24	W21-W27	W27-W30	W30-W33	Assembly
150	W21-W24	W21-W24	W24-W27	W30-W33	W33-W36	Storage

<b>Table A35</b> Girder Sizes						<b>Beam Span</b> <b>35 feet</b>
Live Load, psf	Girder Span: G1 (ft)					Classification
	20	25	30	35	40	
50	W18-W21	W21-W24	W24-W27	W24-W27	W27-W30	Office
100	W21-W24	W24-W27	W24-W30	W24-W30	W30-W33	Assembly
150	W14-W18	W18-W21	W18-W24	W21-W27	W27-W30	Storage

<b>Table A40</b> Girder Sizes						<b>Beam Span</b> <b>40 feet</b>
Live Load, psf	Girder Span: G1 (ft)					Classification
	20	25	30	35	40	
50	W21-W24	W21-W24	W24-W27	W24-W27	W27-W33	Office
100	W24-W27	W24-W27	W24-W27	W27-W30	W30-W33	Assembly
150	W21-W24	W24-W27	W24-W27	W30-W36	W33-W36	Storage



**Tables B to B40**

- Dead load includes system self weight (slab + steel)
- Superimposed dead load = 25 psf (partitions + MEP)
- Loads are uniformly distributed over bay area
- 4½ in. normal weight concrete topping
- 2 in. composite metal decking
- 50 ksi steel yield
- 3 ksi concrete strength
- 2-hour fire rating

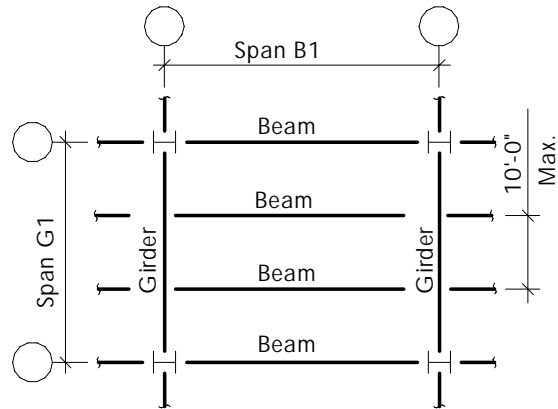


Table B						
Beam Sizes						
Live Load, psf	Beam Span: B1 (ft)					Classification
	20	25	30	35	40	
50	W12-W16	W16-W21	W18-W24	W21-W24	W24-W27	Office
100	W14-W16	W16-W21	W18-W24	W21-W27	W27-W30	Assembly
150	W14-W18	W16-W18	W21-W24	W24-W30	W27-W33	Storage

Table B20						Beam Span 20 feet
Girder Sizes						
Live Load, psf	Girder Span: G1 (ft)					Classification
	20	25	30	35	40	
50	W21-W24	W21-W24	W24-W27	W24-W27	W27-W33	Office
100	W24-W27	W24-W27	W24-W27	W27-W30	W30-W33	Assembly
150	W21-W24	W24-W27	W24-W27	W30-W36	W33-W36	Storage



<b>Table B25</b> Girder Sizes						<b>Beam Span</b> <b>25 feet</b>
Live Load, psf	Girder Span: G1 (ft)					Classification
	20	25	30	35	40	
50	W16-W18	W21-W24	W24-W27	W27-W30	W27-W33	Office
100	W16-W21	W18-W24	W21-W30	W27-W30	W30-W33	Assembly
150	W18-W24	W21-W24	W24-W27	W27-W30	W30-W36	Storage

<b>Table B30</b> Girder Sizes						<b>Beam Span</b> <b>30 feet</b>
Live Load, psf	Girder Span: G1 (ft)					Classification
	20	25	30	35	40	
50	W16-W21	W18-W24	W21-W24	W24-W27	W27-W30	Office
100	W18-W24	W21-W27	W21-W24	W24-W30	W24-W33	Assembly
150	W18-W24	W24-W30	W27-W33	W27-W33	W30-W36	Storage

<b>Table B35</b> Girder Sizes						<b>Beam Span</b> <b>35 feet</b>
Live Load, psf	Girder Span: G1 (ft)					Classification
	20	25	30	35	40	
50	W18-W24	W21-W24	W21-W27	W24-W30	W27-W33	Office
100	W21-W24	W21-W24	W24-W27	W27-W30	W30-W36	Assembly
150	W21-W24	W24-W27	W27-W33	W30-W36	W33-W36	Storage

<b>Table B40</b> Girder Sizes						<b>Beam Span</b> <b>40 feet</b>
Live Load, psf	Girder Span: G1 (ft)					Classification
	20	25	30	35	40	
50	W21-W24	W21-W24	W24-W27	W27-W30	W27-W36	Office
100	W24-W27	W24-W30	W27-W30	W27-W36	W33-W36	Assembly
150	W24-W27	W24-W30	W27-W33	W30-W36	W33-W40	Storage



**Tables C to C40**

- Dead load includes system self weight (slab + steel)
- Superimposed dead load = 25 psf (partitions + MEP)
- Loads are uniformly distributed over bay area
- 4¼ in. lightweight concrete topping
- 2 in. composite metal decking
- 50 ksi steel yield
- 3 ksi concrete strength
- 3-hour fire rating

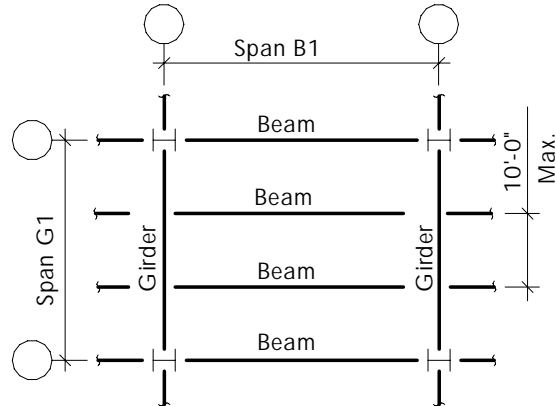


Table C						
Beam Sizes						
Live Load, psf	Beam Span: B1 (ft)					Classification
	20	25	30	35	40	
50	W10-W16	W14-W16	W16-W21	W18-W21	W21-W27	Office
100	W12-W16	W14-W18	W16-W24	W21-W24	W21-W27	Assembly
150	W14-W16	W16-W21	W18-W24	W21-W27	W24-W30	Storage

Table C20						Beam Span 20 feet
Girder Sizes						
Live Load, psf	Girder Span: G1 (ft)					Classification
	20	25	30	35	40	
50	W16-W18	W18-W21	W21-W24	W21-W24	W24-W30	Office
100	W16-W18	W18-W21	W21-W24	W24-W27	W24-W30	Assembly
150	W16-W21	W18-W21	W21-W24	W24-W27	W27-W33	Storage





<b>Table C25</b> Girder Sizes						<b>Beam Span</b> <b>25 feet</b>
Live Load, psf	Girder Span: G1 (ft)					Classification
	20	25	30	35	40	
50	W16-W18	W16-W21	W21-W24	W21-W27	W24-W27	Office
100	W18-W21	W18-W24	W21-W24	W24-W30	W24-W30	Assembly
150	W18-W21	W21-W24	W24-W30	W27-W33	W30-W36	Storage

<b>Table C30</b> Girder Sizes						<b>Beam Span</b> <b>30 feet</b>
Live Load, psf	Girder Span: G1 (ft)					Classification
	20	25	30	35	40	
50	W18-W21	W18-W24	W21-W24	W24-W27	W27-W30	Office
100	W18-W21	W21-W24	W21-W30	W24-W33	W27-W36	Assembly
150	W21-W24	W24-W30	W24-W33	W27-W33	W30-W36	Storage

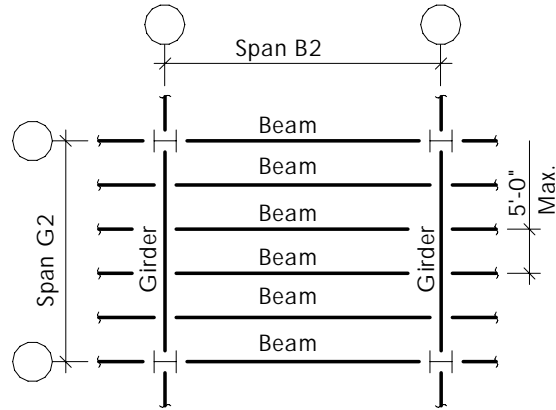
<b>Table C35</b> Girder Sizes						<b>Beam Span</b> <b>35 feet</b>
Live Load, psf	Girder Span: G1 (ft)					Classification
	20	25	30	35	40	
50	W18-W24	W21-W24	W24-W27	W24-W30	W27-W30	Office
100	W21-W24	W21-W27	W24-W30	W27-W33	W30-W36	Assembly
150	W24-W27	W24-W30	W27-W30	W27-W33	W30-W36	Storage

<b>Table C40</b> Girder Sizes						<b>Beam Span</b> <b>40 feet</b>
Live Load, psf	Girder Span: G1 (ft)					Classification
	20	25	30	35	40	
50	W21-W24	W21-W24	W24-W30	W27-W30	W30-W33	Office
100	W24-W27	W24-W30	W24-W30	W27-W33	W30-W36	Assembly
150	W27-W30	W27-W30	W27-W33	W30-W36	W33-W40	Storage



**Tables D to D40**

- Dead load includes system self weight (slab + steel)
- Superimposed dead load = 20 psf (roofing systems + MEP)
- Loads are uniformly distributed over bay area
- 1½ in. metal roof decking
- 50 ksi steel yield



<b>Table D</b> Beam Sizes					
Live Load, psf	Beam Span: B2 (ft)				
	20	25	30	35	40
20	W12-W16	W12-W16	W14-W18	W16-W21	W18-W24
30	W12-W16	W14-W16	W16-W21	W18-W24	W21-W24
40	W14-W16	W16-W21	W18-W21	W21-W24	W21-W27

<b>Table D20</b> Girder Sizes					Beam Span 20 feet
Live Load, psf	Girder Span: G2 (ft)				
	20	25	30	35	40
20	W16-W18	W16-W18	W18-W24	W21-W24	W24-W27
30	W16-W18	W16-W21	W18-W24	W21-W27	W24-W30
40	W18-W21	W18-W24	W21-W24	W24-W27	W24-W30



<b>Table D25</b> Girder Sizes					<b>Beam Span</b> 25 feet
Live Load, psf	Girder Span: G2 (ft)				
	20	25	30	35	40
20	W16-W18	W16-W21	W21-W24	W21-W24	W24-W27
30	W18-W21	W18-W21	W21-W24	W21-W27	W24-W30
40	W18-W21	W18-W24	W21-W24	W24-W30	W27-W33

<b>Table D30</b> Girder Sizes					<b>Beam Span</b> 30 feet
Live Load, psf	Girder Span: G2 (ft)				
	20	25	30	35	40
20	W18-W21	W18-W24	W21-W24	W24-W27	W24-W30
30	W18-W21	W21-W24	W21-W30	W24-W30	W27-W33
40	W18-W21	W21-W27	W24-W30	W27-W30	W27-W33

<b>Table D35</b> Girder Sizes					<b>Beam Span</b> 35 feet
Live Load, psf	Girder Span: G2 (ft)				
	20	25	30	35	40
20	W18-W24	W21-W24	W24-W27	W24-W30	W27-W30
30	W21-W24	W21-W24	W24-W30	W24-W30	W30-W33
40	W21-W24	W21-W24	W24-W30	W27-W33	W30-W36

<b>Table D40</b> Girder Sizes					<b>Beam Span</b> 40 feet
Live Load, psf	Girder Span: G2 (ft)				
	20	25	30	35	40
20	W21-W24	W21-W24	W24-W27	W27-W30	W27-W33
30	W21-W24	W24-W27	W24-W30	W27-W33	W30-W33
40	W24	W24-W30	W27-W30	W27-W33	W30-W36



**Table E**

Span Ranges

Representative Span Ranges of Different Structural Steel Components												
Component	Span Range, feet											
	10	20	40	60	80	100						
<b>Roof Framing</b>												
1 ½ in. Metal Deck	■											
3 in. Metal Deck	■	■										
6 in. Metal Deck		■	■									
Beams (See Tables)			■	■								
Girders (See Tables)		■	■	■								
<b>Joists</b>												
K Series		■	■	■								
LH Series			■	■	■	■						
<b>Floor Framing</b>												
Composite Slab		■	■									
Noncomposite Slab	■	■										
Beams (See Tables)			■	■	■							
Girders (See Tables)		■	■	■								
<b>Long Spans</b>												
Plate Girders – Fabricated Beams					■	■	■					
Trusses – Fabricated				■	■	■	■	■	■	■	▶	
Joists "DLH/SLH" Series								■	■	■	▶	
Space Frames				■	■	■	■	■	■			



## DETERMINING INTERIOR COLUMN SIZES

Determining the overall size for column enclosures is a function of the column dimensions as well as utility services which may be running vertically, immediately adjacent to the columns. Column sizes determined by the structural engineer must account for gravity loads as well as lateral loads. Having a fairly accurate selection of a column size during the planning and schematic design phases of a project can greatly assist the architectural and interior design teams.

Preliminary column dimensions have been tabulated for buildings ranging from one story to six stories. Two different commonly used floor live loadings have been tabulated. One roof live loading was selected to be used for each of the floor live loadings. The selection of a single roof live load was found to have a very minimal effect on the overall column size selection. The interior columns are assumed not to contribute to the lateral load resisting system for the building. The tables presented (see Table sets F, G and H) indicate representative interior column dimensions for square and rectangular bay sizes ranging from 20 ft × 20 ft to 40 ft × 40 ft. Each set of tables represents a different floor construction type meeting a two-hour fire rated floor system.

Exterior columns have not been considered in the formulation of the column size tables for two reasons. First, exterior columns are commonly engaged as part of the lateral load resisting system, particularly in the case of moment resistant lateral frames. Secondly, exterior beams and girders often transfer exterior wall loads to the exterior columns. Façade types as well as façade loads can vary significantly. As a result it would be difficult to formulate a concise set of generalized tables to account for these conditions. As a general "rule of thumb", exterior columns can be approximated to be the same size as interior columns.

As with any design problem there are many solutions. Each project will have a unique set of loading parameters. The design information and example have been prepared accurately and consistent with current structural design practice for several different load cases. The information presented in this publication has been prepared in accordance with recognized engineering principles and is for general information only. While it is believed to be accurate, this information should not be used or relied upon without competent professional examination and verification of its accuracy, suitability, and applicability by a licensed professional engineer, designer, or architect.

### Design Parameters and Limitations

Many specific parameters and limitations go into the design of any structural member. Imposed loadings caused by earthquake, wind, snow, rain, construction methods, etc. vary across the country. Live loads are specified in the applicable building codes. Dead loads are much more system-dependent and require special attention in their computation. Specific requirements for serviceability, strength, lateral stability of individual elements, and the lateral resistance of the building all contribute to the design of a safe and efficient building. The information presented in the tables to follow is intended for use establishing preliminary interior column dimensions only without regard to earthquake loading or contributing to lateral resistance of the building.

Column dimensions have been selected based on properties for rolled wide flange shapes, as well as hollow structural section and pipe column shapes. Bay sizes range from 20 ft × 20 ft to 40 ft × 40 ft in 5 ft increments. Both square and rectangular bays have been accounted for. As a result, 15 different bay sizes for each of two load cases have been tabulated for three different slab construction types. Dead loads address the self-weight of the floor/roof framing system.



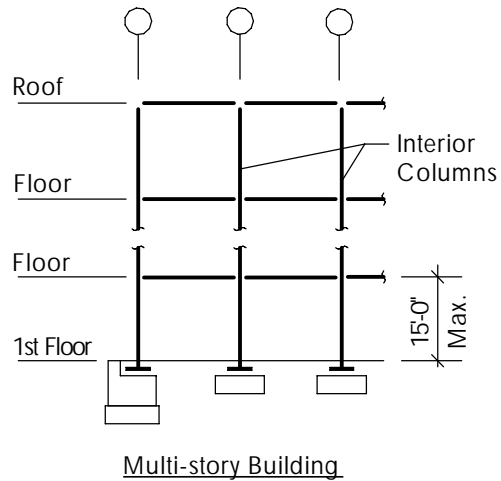
**Interior column sizing tables are based on the following parameters:**

- *Load and Resistance Factor Design Specification*, American Institute of Steel Construction, 1999
- Live and dead loads are uniformly distributed over a bay area
- Full live load has been applied to a full bay: No live load reduction has been taken into account
- Maximum floor-to-floor height is 15 ft
- Column sizes tabulated do not account for lateral resistance of the building
- All connections to the columns are considered to be "simple" connections—no moment transfer from beam/girder to column has been considered
- Normal weight concrete unit weight used in the designs is 145 pcf; lightweight concrete unit weight used in the designs is 110 pcf
- A maximum 40 psf roof live load has been considered for all column designs
- 35 ksi steel yield has been used for pipe columns
- 46 ksi steel yield has been used for hollow structural section columns
- 50 ksi steel yield has been used for rolled wide flange columns
- Only square hollow structural sections have been used in the tabulated dimensions
- Actual dimensions have been tabulated. The involvement of a qualified structural engineer shall determine actual pipe, hollow structural section, or rolled wide flange section designation required for any specific project and loading condition.



### Interior Column Sizing Table F1

- 3/4 in. lightweight topping
- 2 in. metal decking
- Floor live load = 50 psf
- Roof live load = 40 psf



**Table F1**

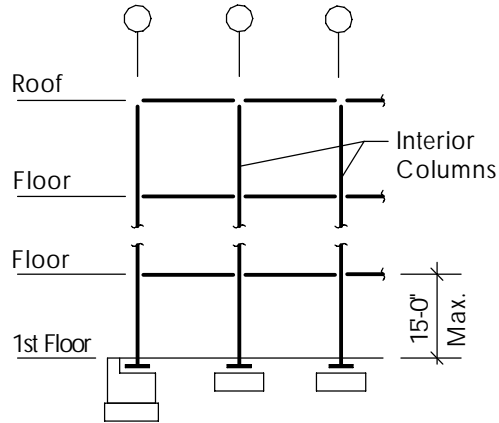
Typical Interior Column Size (Depth × Width)

BAY SPACING	NUMBER OF STORIES					
	1	2	3	4	5	6
20 X 20	4 X 4	6 X 6	10 X 10	12 X 10	14 X 10	14¼ X 10¼
20 X 25	4 X 4	8 X 8	10 X 10	12 X 10	14 X 10	14¼ X 10¼
20 X 30	5 X 5	8 X 8	10 X 10	12 X 10	14 X 10	14¼ X 10¼
20 X 35	5 X 5	10 X 8	10¼ X 10	12¼ X 12	14¼ X 10¼	14 X 14½
20 X 40	6 X 6	10 X 8	10¼ X 10	12¼ X 12	14¼ X 10¼	14 X 14½
25 X 25	4 X 4	7 X 7	10 X 10	12 X 10	14¼ X 10¼	14¼ X 10¼
25 X 30	5 X 5	7 X 7	10¼ X 10	12¼ X 12	14¼ X 10¼	14 X 14½
25 X 35	5 X 5	8½ X 8½	12¼ X 10	12¼ X 12¼	14 X 14½	14¼ X 14¾
25 X 40	5 X 5	8½ X 8½	12¼ X 10	12¼ X 12¼	14 X 14½	14¼ X 14¾
30 X 30	5 X 5	8½ X 8½	12¼ X 10	12¼ X 12¼	14 X 14½	14¼ X 14¾
30 X 35	5 X 5	8½ X 8½	12¼ X 12	14 X 14½	14¼ X 14¾	14½ X 14¾
30 X 40	5 X 5	10¼ X 10¼	12¼ X 12	14 X 14½	14¼ X 14¾	14½ X 14¾
35 X 35	6 X 6	10¼ X 10¼	12¼ X 12	14 X 14½	14¼ X 14¾	14½ X 14¾
35 X 40	6 X 6	10¼ X 10¼	12½ X 12¼	14¼ X 14¾	14½ X 14¾	15 X 15¾
40 X 40	8 X 8	12¼ X 10	12½ X 12¼	14¼ X 14¾	14½ X 14¾	15 X 15¾



### Interior Column Sizing Table F2

- 3¼ in. lightweight topping
- 2 in. metal decking
- Floor live load = 100 psf
- Roof live load = 40 psf



Multi-story Building

**Table F2**

Typical Interior Column Size (Depth × Width)

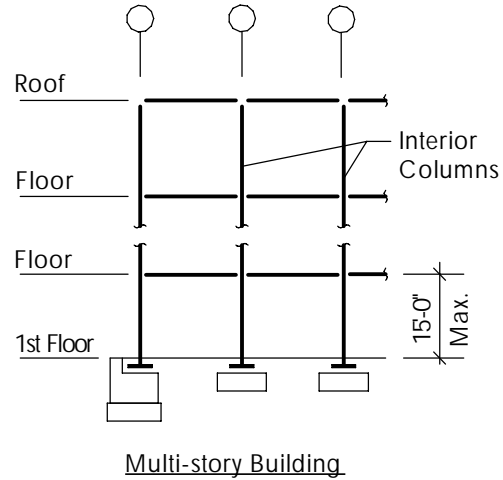
BAY SPACING	NUMBER OF STORIES					
	1	2	3	4	5	6
20 X 20	4 X 4	6 X 6	10 X 10	12¼ X 12	12¼ X 12	12½ X 12¼
20 X 25	4 X 4	6 X 6	10 X 10	12¼ X 12	12¼ X 12	12½ X 12¼
20 X 30	5 X 5	6 X 6	10 X 10	12¼ X 12	12¼ X 12	12½ X 12¼
20 X 35	5 X 5	8 X 8	10¼ X 10¼	12¼ X 12	12¾ X 12¼	13 X 12¼
20 X 40	6 X 6	8 X 8	10¼ X 10¼	12¼ X 12	12¾ X 12¼	13 X 12¼
25 X 25	4 X 4	6 X 6	10 X 10	12¼ X 12	12½ X 12	12½ X 12¼
25 X 30	5 X 5	7 X 7	12¼ X 12	12¾ X 12¼	13¼ X 12½	13½ X 12½
25 X 35	5 X 5	8 X 8	12¼ X 12	12¾ X 12¼	13¼ X 12½	13½ X 12½
25 X 40	5 X 5	8 X 8	12¼ X 12	12¾ X 12¼	13¼ X 12½	13½ X 12½
30 X 30	5 X 5	8 X 8	10¼ X 10¼	12¾ X 12¼	13¼ X 12½	13½ X 12½
30 X 35	5 X 5	10¼ X 10	12½ X 12¼	14½ X 14¾	14¾ X 14¾	15 X 15¾
30 X 40	5 X 5	10¼ X 10	12½ X 12¼	14½ X 14¾	14¾ X 14¾	15 X 15¾
35 X 35	6 X 6	10¼ X 10	12½ X 12¼	14½ X 14¾	14¾ X 14¾	15 X 15¾
35 X 40	6 X 6	10½ X 10¼	13 X 12¼	14½ X 14¾	15¼ X 15¾	15¾ X 15¾
40 X 40	8 X 8	10½ X 10¼	13 X 12¼	14¾ X 14¾	15¼ X 15¾	15¾ X 15¾





### Interior Column Sizing Table G1

- 4½ in. normal weight topping
- 2 in. metal decking
- Floor live load = 50 psf
- Roof live load = 40 psf



**Table G1**

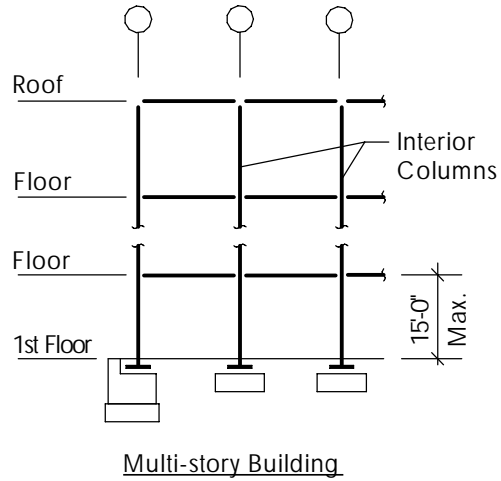
Typical Interior Column Size (Depth × Width)

BAY SPACING	NUMBER OF STORIES					
	1	2	3	4	5	6
20 X 20	4 X 4	8 X 8	8½ X 8¼	10¼ X 10¼	12¼ X 12	12½ X 12¼
20 X 25	4 X 4	8 X 8	8½ X 8¼	10¼ X 10¼	12¼ X 12	12½ X 12¼
20 X 30	5 X 5	8 X 8	8½ X 8¼	10¼ X 10¼	12¼ X 12	12½ X 12¼
20 X 35	5 X 5	8¼ X 8¼	8¾ X 8¼	12¼ X 12	12½ X 12¼	12¾ X 12¼
20 X 40	6 X 6	8¼ X 8¼	8¾ X 8¼	12¼ X 12	12½ X 12¼	12¾ X 12¼
25 X 25	4 X 4	8 X 8	8½ X 8¼	10¼ X 10¼	12¼ X 12	12½ X 12¼
25 X 30	5 X 5	8¼ X 8¼	8¾ X 8¼	12¼ X 12	12½ X 12¼	12¾ X 12¼
25 X 35	5 X 5	8½ X 8¼	10¼ X 10¼	12½ X 12¼	12¾ X 12¼	13 X 12½
25 X 40	5 X 5	8½ X 8¼	10¼ X 10¼	12½ X 12¼	12¾ X 12¼	13 X 12½
30 X 30	5 X 5	8½ X 8¼	10¼ X 10¼	12½ X 12¼	12¾ X 12¼	13 X 12½
30 X 35	5 X 5	8½ X 8¼	12¼ X 12	14 X 14½	14½ X 14¾	14¾ X 14¾
30 X 40	5 X 5	8¾ X 8¼	12¼ X 12	14 X 14½	14½ X 14¾	14¾ X 14¾
35 X 35	6 X 6	8¾ X 8¼	12¼ X 12	14 X 14½	14½ X 14¾	14¾ X 14¾
35 X 40	6 X 6	10¼ X 10¼	12½ X 12¼	14½ X 14¼	14¾ X 15½	15¼ X 15¾
40 X 40	8 X 8	10¼ X 10¼	12½ X 12¼	14½ X 14¼	14¾ X 15½	15¼ X 15¾



### Interior Column Sizing Table G2

- 4½ in. normal weight topping
- 2 in. metal decking
- Floor live load = 100 psf
- Roof live load = 40 psf



**Table G2**

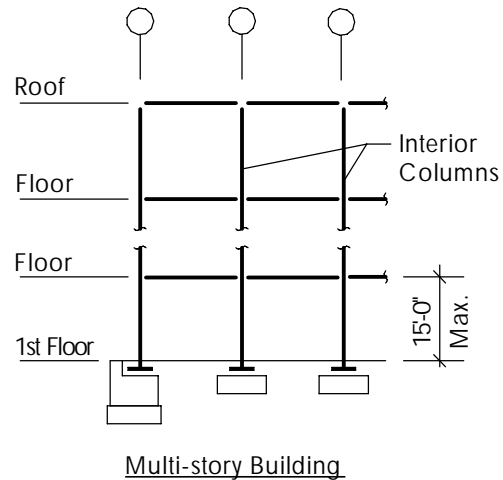
Typical Interior Column Size (Depth × Width)

BAY SPACING	NUMBER OF STORIES					
	1	2	3	4	5	6
20 X 20	4 X 4	8 X 8	8½ X 8¼	10¼ X 10¼	12¼ X 12	12½ X 12¼
20 X 25	4 X 4	8 X 8	8½ X 8¼	10¼ X 10¼	12¼ X 12	12½ X 12¼
20 X 30	5 X 5	8 X 8	8½ X 8¼	10¼ X 10¼	12¼ X 12	12½ X 12¼
20 X 35	5 X 5	8¼ X 8¼	8¾ X 8¼	12¼ X 12	12½ X 12¼	12¾ X 12¼
20 X 40	6 X 6	8¼ X 8¼	8¾ X 8¼	12¼ X 12	12½ X 12¼	12¾ X 12¼
25 X 25	4 X 4	8 X 8	8½ X 8¼	10¼ X 10¼	12¼ X 12	12½ X 12¼
25 X 30	5 X 5	8¼ X 8¼	8¾ X 8¼	12¼ X 12	12½ X 12¼	12¾ X 12¼
25 X 35	5 X 5	8½ X 8¼	10¼ X 10¼	12½ X 12¼	12¾ X 12¼	13 X 12½
25 X 40	5 X 5	8½ X 8¼	10¼ X 10¼	12½ X 12¼	12¾ X 12¼	13 X 12½
30 X 30	5 X 5	8½ X 8¼	10¼ X 10¼	12½ X 12¼	12¾ X 12¼	13 X 12½
30 X 35	5 X 5	8½ X 8¼	12¼ X 12	14 X 14½	14½ X 14¾	14¾ X 14¾
30 X 40	5 X 5	8¾ X 8¼	12¼ X 12	14 X 14½	14½ X 14¾	14¾ X 14¾
35 X 35	6 X 6	8¾ X 8¼	12¼ X 12	14 X 14½	14½ X 14¾	14¾ X 14¾
35 X 40	6 X 6	10¼ X 10¼	12½ X 12¼	14½ X 14¼	14¾ X 15½	15¼ X 15¾
40 X 40	8 X 8	10¼ X 10¼	12½ X 12¼	14½ X 14¼	14¾ X 15½	15¼ X 15¾



### Interior Column Sizing Table H1

- 4¼ in. lightweight topping
- 2 in. metal decking
- Floor live load = 50 psf
- Roof live load = 40 psf



**Table H1**

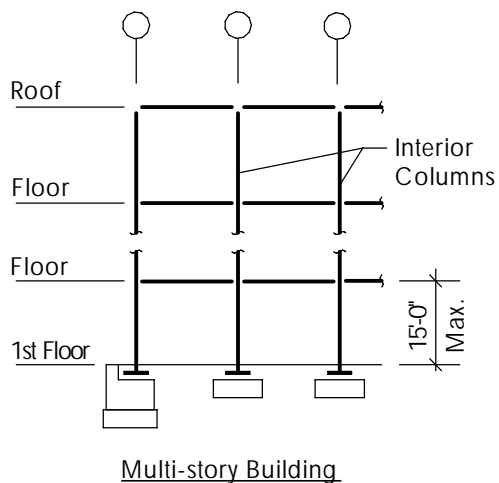
Typical Interior Column Size (Depth × Width)

BAY SPACING	NUMBER OF STORIES					
	1	2	3	4	5	6
20 X 20	4 X 4	6 X 6	10¼ X 8	12 X 10	14 X 10	12¼ X 12
20 X 25	4 X 4	8 X 8	10¼ X 8	12 X 10	14 X 10	12¼ X 12
20 X 30	5 X 5	8 X 8	10¼ X 8	12 X 10	14 X 10	12¼ X 12
20 X 35	5 X 5	10 X 8	10¼ X 10	12¼ X 12	12¼ X 12	12½ X 12¼
20 X 40	6 X 6	10 X 8	10¼ X 10	12¼ X 12	12¼ X 12	12½ X 12¼
25 X 25	4 X 4	7 X 7	10¼ X 8	12 X 10	14¼ X 10¼	14¼ X 10¼
25 X 30	5 X 5	10 X 8	10¼ X 10	12¼ X 12	12¼ X 12	12½ X 12¼
25 X 35	5 X 5	8½ X 8½	12¼ X 10	12¼ X 12¼	14 X 14½	14¼ X 14¾
25 X 40	5 X 5	8½ X 8½	12¼ X 10	12¼ X 12¼	14 X 14½	14¼ X 14¾
30 X 30	5 X 5	8½ X 8½	12¼ X 10	12¼ X 12¼	14 X 14½	14¼ X 14¾
30 X 35	5 X 5	8½ X 8½	12¼ X 12	12½ X 12¼	14¼ X 14¾	14½ X 14¾
30 X 40	5 X 5	10¼ X 10¼	12¼ X 12	12½ X 12¼	14¼ X 14¾	14½ X 14¾
35 X 35	6 X 6	10¼ X 10¼	12¼ X 12	12½ X 12¼	14¼ X 14¾	14½ X 14¾
35 X 40	6 X 6	10¼ X 10¼	12½ X 12¼	14¼ X 14¾	14½ X 14¾	15 X 15¾
40 X 40	8 X 8	12¼ X 10	12½ X 12¼	14¼ X 14¾	14½ X 14¾	15 X 15¾



## Interior Column Sizing Table H2

- 4¼ in. lightweight topping
- 2 in. metal decking
- Floor live load = 100 psf
- Roof live load = 40 psf



**Table H2**

Typical Interior Column Size (Depth × Width)

BAY SPACING	NUMBER OF STORIES					
	1	2	3	4	5	6
20 X 20	4 X 4	6 X 6	10 X 10	10½ X 10¼	12½ X 12¼	12¾ X 12¼
20 X 25	4 X 4	6 X 6	10 X 10	10½ X 10¼	12½ X 12¼	12¾ X 12¼
20 X 30	5 X 5	6 X 6	10 X 10	10½ X 10¼	12½ X 12¼	12¾ X 12¼
20 X 35	5 X 5	8 X 8	10¼ X 10¼	12½ X 12¼	12¾ X 12¼	14½ X 14¾
20 X 40	6 X 6	8 X 8	10¼ X 10¼	12½ X 12¼	12¾ X 12¼	14½ X 14¾
25 X 25	4 X 4	6 X 6	10 X 10	10½ X 10¼	12½ X 12¼	12¾ X 12¼
25 X 30	5 X 5	7 X 7	12¼ X 12	12½ X 12¼	13¼ X 12½	14½ X 14¾
25 X 35	5 X 5	8 X 8	12¼ X 12	12¾ X 12¼	13¼ X 12½	14¾ X 15½
25 X 40	5 X 5	8 X 8	12¼ X 12	12¾ X 12¼	13¼ X 12½	14¾ X 15½
30 X 30	5 X 5	8 X 8	10¼ X 10¼	12¾ X 12¼	13¼ X 12½	14¾ X 15½
30 X 35	5 X 5	10¼ X 10	12½ X 12¼	14½ X 14¾	14¾ X 14¾	15 X 15¾
30 X 40	5 X 5	10¼ X 10	12½ X 12¼	14½ X 14¾	14¾ X 14¾	15 X 15¾
35 X 35	6 X 6	10¼ X 10	12½ X 12¼	14½ X 14¾	14¾ X 14¾	15 X 15¾
35 X 40	6 X 6	10½ X 10¼	13 X 12¼	14¾ X 15½	15¼ X 15¾	15¾ X 15¾
40 X 40	8 X 8	10½ X 10¼	13 X 12¼	14¾ X 15½	15¼ X 15¾	15¾ X 15¾



## PART IV

### MISCELLANEOUS

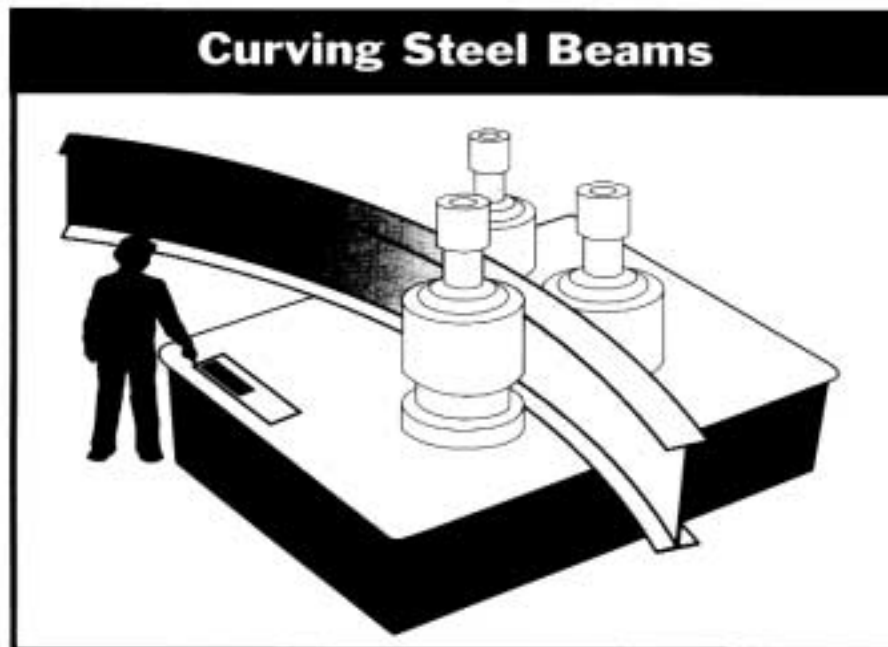
#### BENDING AND SHAPING OF STRUCTURAL MEMBERS

With modern specialized bending and shaping equipment, the architect now has a great deal of flexibility to design with curved steel members whether it be for façades, arches, domes or special accent features. Steel designs need no longer be thought of as strictly rectilinear. Also, there is an array of shapes to choose from to be used as curved members:

- Bars: round, flat and square
- Hollow structural sections: round, rectangular and square
- Channels
- Angles
- Tees

There are several methods of bending steel shapes. A common one involves groups of rolls consisting of a combination of fixed and moveable or "pinch" rolls whose pressure can be adjusted according to the particular material being formed. This is illustrated in Figure 41.

The sizes that can now be curved range from a  $\frac{3}{8}$ -in. diameter hollow structural section to a 44 in. deep wide-flange beam. The shapes and an approximation of the upper size limits for bending are shown in Table 11.



**Figure 41.** Bending steel shapes with pinch rollers



**Table 11**  
Bent and Rolled Standard Mill Shapes

<p><b>1</b> Angle Rings Leg Out 10"x10"x1" Angle</p>	<p><b>12</b> Tee Rings Stem Out 18"x179<sup>1</sup>/<sub>2</sub># Tee</p>
<p><b>2</b> Angle Rings Leg In 10"x10"x1" Angle</p>	<p><b>13</b> Tee Rings Stem Up 18"x179<sup>1</sup>/<sub>2</sub># Tee</p>
<p><b>3</b> Flat Bar Rings The Hard Way 24"x10" Flat</p>	<p><b>14</b> Angle Rings Heel In 8"x8"x1" Angle</p>
<p><b>4</b> Flat Bar Rings The Easy Way 36"x12" Flat</p>	<p><b>15</b> Angle Rings Heel Out 8"x8"x1" Angle</p>
<p><b>5</b> Square Bar Rings 18" Square</p>	<p><b>16</b> Angle Rings Heel Up 8"x8"x1" Angle</p>
<p><b>6</b> Beam Rings The Easy Way (Y-Y Axis) 44"x 285#, 36"x 848#</p>	<p><b>17</b> Square &amp; Rectangular Tube Rings 16" Square Tube 20"x12"x<sup>1</sup>/<sub>2</sub>" Tube</p>
<p><b>7</b> Beam Rings The Hard Way (X-X Axis) 44"x 224#</p>	<p><b>18</b> Round Tube &amp; Pipe Rings 20" Sched. 80 Pipe</p>
<p><b>8</b> Channel Rings Flanges In Any Size</p>	<p><b>19</b> Round Bar Rings Any Size</p>
<p><b>9</b> Channel Rings Flanges Out Any Size</p>	<p><b>20</b> Rail Rings Ball In Any Size</p>
<p><b>10</b> Channel Rings The Hard Way (X-X Axis) Any Size</p>	<p><b>21</b> Rail Rings Ball Out Any Size</p>
<p><b>11</b> Tee Rings Stem In 18"x179<sup>1</sup>/<sub>2</sub># Tee</p>	<p><b>22</b> Rail Rings Ball Up Any Size</p>

Chart courtesy of Chicago Metal Rolled Products Company.



The practical limits on the degree of bending depend on several factors:

- The tightness of the radius—the tighter (smaller) the radius, the more severe the bend.
- The shape and size of the material.
- The yield strength of the material—lower yield strengths are generally easier to form.
- The capacity of the bending equipment, which will vary by company.
- The skill of the machine operator—although the machines are sophisticated, bending to exacting specifications is part art.

Considerations for acceptable bending tolerances and allowable deformations vary. Depending upon material sizes and amount of curvature, some deformation may occur. If exterior cladding or interior finish work hides the member, any deformation may not be objectionable. If members are exposed, possible deformations may have to be considered. Consult with your steel fabricator for a detailed explanation.

For cases where length of curvature exceeds practical limits (40-50 ft), it is possible to make segmented curves made up of individual pieces welded together to form a single arc. This is illustrated in Figure 42. In some cases it may be necessary to weld sections together due to limitations on shipping widths and lengths.

Most architectural applications do not exceed modern bending limits or acceptable deformation. Specific limitations on bending capabilities should be obtained from those that provide the service.

## WELDING SYMBOLS AND APPEARANCE OF EXPOSED WELDED CONNECTIONS

Welding is commonly recognized within the steel industry as a way to connect steel components. There are numerous types of welding procedures available, but the only procedure acceptable in structural work is fusion welding by electric arc. The components to be joined, and some metal from a welding rod, are heated to a temperature where the metals all fuse together. The welding process can be accomplished in the field or in the fabrication shop. Shop welding is done either manually or is automated with the aid of computer programs.

In some applications, welded connections are most desirable than bolted ones. Generally, welded connections have a "cleaner" and lighter appearance than bolted connections, which may be desirable in exposed steel connections. Also, welded connections may be smaller than bolted ones because the weld length required for the connection may be substantially less than the length of bolt rows required for the same connection.

There are basically two types of commonly used welds—fillet welds and groove welds. Fillet welds have a cross section that is approximately triangular in shape as illustrated in Figure 43. The type of weld is commonly used to join two surfaces at right angles to each other.

The strength of the weld is determined from the throat dimension. Weld sizes that are  $\frac{5}{16}$ -in. or less can be made in one pass (one progression of an electrode along the axis of the weld), and are thus most economical. Larger weld sizes require multiple passes and are more expensive.

The other common type of weld is the groove weld. Groove welds are used to join two abutting parts lying in approximately the same plane (Figure 44). They are categorized by the method of



Figure 42. Made-up segmented curves



preparation of the abutting parts prior to depositing the weld metal. For example, a weld where one of the plates is notched on one side to receive the weld is called a single-bevel groove weld. A weld where one side of each of the plates is notched to receive the welds is called a single-V groove weld. The types of groove welds are classified as either partial penetration or full penetration groove welds. Partial penetration welds are welds where the required weld strength can be achieved by preparing only a partial depth of the part to be welded. A full penetration weld is a weld where the required weld strength can only be achieved by preparing the entire depth of the parts to be joined.

Since the weld metal generally has a higher strength than the parts that are being joined, a full penetration weld connection has as much strength as if the adjoining were not connected, but monolithic. Table 12 indicates information that is provided on a weld symbol as well as the proper locations for that information. Table 12 identifies several types of basic welding symbols that are commonly seen on design documents and shop drawings.

A different type of weld that should be addressed is the "seal weld." This is not a technical term, nor is it a recognized weld type, but it is a term that is frequently used when non-structural weld material is desired to fill gaps or prevent water infiltration, such as a cap for an exterior pipe column.

First, it must be mentioned that seal welds should be avoided whenever possible. They are very small welds that mate parts that are generally much thicker than the weld itself. The thicker materials have a tendency to absorb the heat from the small seal weld, which cools very quickly. Since the weld cools so quickly it has a tendency to crack and be ineffective.

In lieu of a seal weld, there are three suggested alternatives that would apply to the pipe column cap, as well as other conditions. Using the column caps as an example, the first alternative would be to tack weld the cap to the pipe column, and use a high-grade sealant to create the watertight seal at the perimeter of the cap. The advantage of this alternate is that it is probably the most cost effective solution. However, the disadvantage is that a sealant will at some point need maintenance. Also, matching the color of a non-paintable sealant to the paint color of the pipe may be difficult to do.

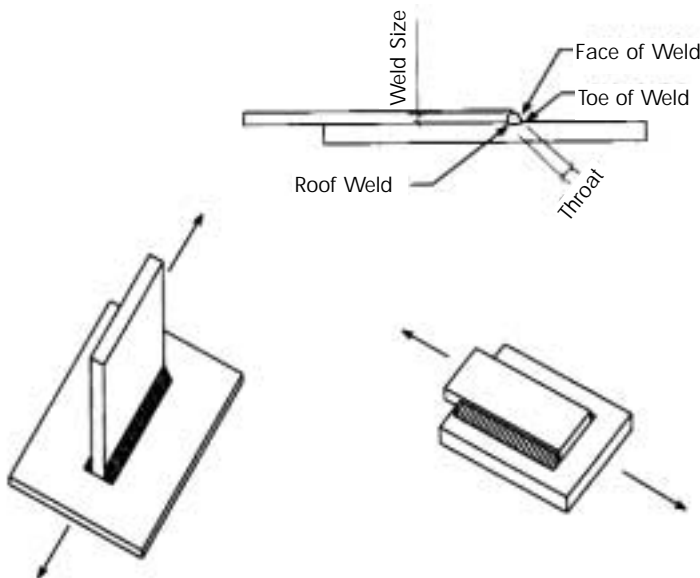


Figure 43. Fillet welds

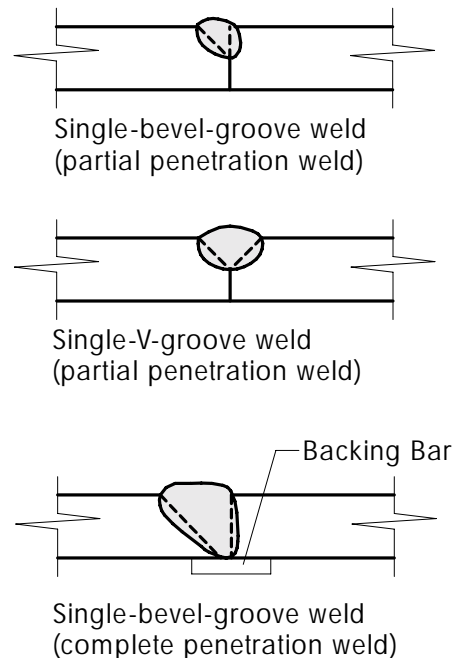


Figure 44. Groove welds





A second alternative is to provide a structural weld to connect the cap to the column. The advantage of this option is that the weld would be continuous, maintenance-free, and watertight. The weld could also be ground smooth to provide a monolithic appearance between the column and the cap. The disadvantage of this solution is that it is a more expensive solution (at least initially) than using a sealant.

Finally, a third viable solution would be to design the cap plate to have a slightly larger radius than the outside diameter of the column. The pipe could then have a continuous weld around the top of the column. The advantage to this solution is that the larger cap makes the connection easy to fabricate, and therefore, is cost effective. There are no real disadvantages, assuming that the aesthetic of the connection is acceptable.

### **LATEST CODE PROVISIONS FOR ARCHITECTURALLY EXPOSED STRUCTURAL STEEL**

The latest edition of the *Code of Standard Practice for Steel Buildings and Bridges*, which was adopted by the American Institute of Steel Construction in 2000, includes provisions for steel that is exposed to view and is to be aesthetically pleasing. Section 10 from the *Code* specifically addresses architecturally exposed structural steel. The entire *Code* is reprinted in the Appendix.



**Table 12**

Typical Welding Symbols

Basic Welding Symbols and Their Location Significance								
Location Significance	Fillet	Plug or Slot	Spot or Projection	Stud	Seam	Back or Backing	Surfacing	Edge
Arrow Side								
Other Side				Not Used			Not Used	
Both Sides		Not Used	Not Used	Not Used	Not Used	Not Used	Not Used	
No Arrow Side or Other Side Significance	Not Used	Not Used		Not Used		Not Used	Not Used	Not Used
Location Significance	Groove							Scarf for Brazed Joint
	Square	V	Bevel	U	J	Flare-V	Flare-Bevel	
Arrow Side								
Other Side								
Both Sides								
No Arrow Side or Other Side Significance		Not Used	Not Used	Not Used	Not Used	Not Used	Not Used	Not Used
Supplementary Symbols				Location of Elements of a Welding Symbol				
Weld-All Around	Fillet Weld	Melt-Thru	Consumable Insert					
Backing Spacer (Rectangular)	Contour							
Backing	Flush	Convex	Concave					
Spacer								
Basic Joints				Identification of Arrow Side and Other Side Joint				
Butt Joint		Corner Joint						
T-Joint		Lap Joint		Edge Joint		Process Abbreviations		
						Where process abbreviations are to be included in the tail of the welding symbol, reference is made to Table 1, Designation of Welding and Allied Processes by Letters, of ANSI/AWS A2-4-98.		
						American Welding Society 550 N.W. LeJeune Road Miami, Florida 33126		

Charts courtesy of the American Welding Society. It should be understood that these charts are intended only as shop aids. The only complete and official presentation of the standard welding symbols is in A2.4.



**Table 12 (Continued)**

Typical Welding Symbols

Typical Welding Symbols		
<p><b>Double-Fillet Welding Symbol</b></p> <p>Weld size Length</p> <p>Omission of length indicates that weld extends between abrupt changes in direction or as dimensioned</p>	<p><b>Chain Intermittent Fillet Welding Symbol</b></p> <p>Pitch (distance between centers) of increments Size (length of leg) Length of increments</p>	<p><b>Staggered Intermittent Fillet Welding Symbol</b></p> <p>Pitch (distance between centers) of increments Size (length of leg) Length of segments</p>
<p><b>Plug Welding Symbol</b></p> <p>Included angle of countersink Size (diameter of hole at roof) Depth of filling in inches (omission indicates filling to complete)</p>	<p><b>Back Welding Symbol</b></p> <p>Back weld OR</p> <p>2nd operation 1st operation</p>	<p><b>Backing Welding Symbol</b></p> <p>Backing weld OR</p> <p>1st operation 2nd operation</p>
<p><b>Spot Welding Symbol</b></p> <p>Size or strength Number of welds Pitch Process</p>	<p><b>Stud Welding Symbol</b></p> <p>Size Pitch Number of studs</p>	<p><b>Seam Welding Symbol</b></p> <p>Size or strength Increment length Pitch Process</p>
<p><b>Square-Groove Welding Symbol</b></p> <p>Weld size Root opening</p>	<p><b>Square-V Groove Welding Symbol</b></p> <p>Depth of bevel Weld size Root opening Groove angle</p>	<p><b>Double-Bevel-Groove Welding Symbol</b></p> <p>Weld size Weld size Arrow points toward member to be prepared</p>
<p><b>Symbol with Backgouging</b></p>	<p><b>Flare-V Groove Welding Symbol</b></p> <p>Weld size</p>	<p><b>Flare-Bevel-Groove Welding Symbol</b></p> <p>Weld size</p>
<p><b>Multiple Reference Lines</b></p> <p>1st operation on the nearest arrow 2nd operation 3rd operation</p>	<p><b>Complete Penetration</b></p> <p>indicates complete joint penetration regardless of type of weld or joint preparation</p>	<p><b>Edge Welding Symbol</b></p> <p>Weld size</p>
<p><b>Flush or Uppet Welding Symbol</b></p> <p>Process reference</p>	<p><b>Mesh-Thru Symbol</b></p> <p>Root reinforcement</p>	<p><b>Joint with Backing</b></p> <p>R indicates backing removed after welding</p>
<p><b>Joint with Spacer</b></p>	<p><b>Flush Contour Symbol</b></p>	<p><b>Convex Contour Symbol</b></p>
<p><b>With modified groove weld symbol</b></p>	<p><b>Double bevel groove</b></p>	





## CONTENTS OF MATERIALS SECTION

INTRODUCTION .....	3
Availability Listings for Structural Shapes .....	3
W-, S-, C-, MC-, HP-, M-SHAPES AND ANGLES .....	3
General .....	3
Designation .....	4
Dimensional Tolerances .....	4
Specifying Material for W-Shapes .....	4
Specifying Material for M-, S-, C- and MC- Shapes .....	4
Specifying Material for HP-Shapes .....	4
Specifying Material for Angles .....	5
STRUCTURAL TEES (WT-, MT- AND ST-SHAPES) .....	5
General and Designation .....	5
Specifying Material for Structural Tees .....	5
HOLLOW STRUCTURAL SECTIONS (HSS) AND PIPE .....	5
General .....	5
Designation .....	5
Specifying Material for HSS and Pipe .....	6
Dimensional Tolerances .....	6
PLATES AND BARS .....	6
General .....	6
Specifying Thickness .....	7
Dimensional Tolerances .....	7
Specifying Material for Plates and Bars .....	7

### LIST OF TABLES

Table 1	Tensile Group Classification of Structural Shapes .....	8
Table 2	Applicable ASTM Specifications for Various Structural Shapes .....	9
Table 3	Applicable ASTM Specifications for Plates and Bars .....	10
Table 4a	Dimensions for W-Shapes .....	11
Table 4b	Dimensions for HP-Shapes (Bearing Piles) .....	18
Table 4c	Dimensions for M-Shapes .....	19
Table 4d	Dimensions for S-Shapes (American Standard Beams) .....	20



Table 4e	Dimensions for C-Shapes (American Standard Channels) . . . . .	21
Table 4f	Dimensions for MC-Shapes (Miscellaneous Channels). . . . .	22
Table 4g	Dimensions for L-Shapes (Equal and Unequal Leg Angles). . . . .	23
Table 4h	Dimensions for Rectangular and Square HSS . . . . .	27
Table 4i	Dimensions for Round HSS . . . . .	36
Table 4j	Dimensions for Pipes. . . . .	40
Table 4k	WT-Shapes (Split from W-Shapes) . . . . .	41
Table 4l	MT-Shapes (Split from M-Shapes) . . . . .	44
Table 4m	ST-Shapes (Split from S-Shapes). . . . .	44
Table 5a	Surface and Box Perimeters, Surface Areas and Weight-to-Perimeter Ratios for W-Shapes . . . . .	45
Table 5b	Surface and Box Perimeters, Surface Areas and Weight-to-Perimeter Ratios for M-Shapes . . . . .	52
Table 5c	Surface and Box Perimeters, Surface Areas and Weight-to-Perimeter Ratios for S-Shapes. . . . .	53
Table 5d	Surface and Box Perimeters, Surface Areas and Weight-to-Perimeter Ratios for HP-Shapes. . . . .	54
Table 5e	Surface and Box Perimeters, Surface Areas and Weight-to-Perimeter Ratios for C-Shapes (American Standard Channels) . . . . .	55
Table 5f	Surface and Box Perimeters, Surface Areas and Weight-to-Perimeter Ratios for MC-Shapes. . . . .	56
Table 5g	Surface and Box Perimeters, Surface Areas and Weight-to-Perimeter Ratios for Angles. . . . .	57
Table 5h	Surface and Box Perimeters, Surface Areas and Weight-to-Perimeter Ratios for WT-Shapes . . . . .	61
Table 5i	Surface and Box Perimeters, Surface Areas and Weight-to-Perimeter Ratios for MT-Shapes . . . . .	69
Table 5j	Surface and Box Perimeters, Surface Areas and Weight-to-Perimeter Ratios for ST-Shapes . . . . .	70
Table 6a	Surface and Box Perimeters, Surface Areas and Weight-to-Perimeter Ratios for Rectangular (and Square) Hollow Structural Sections . . . . .	71
Table 6b	Surface and Box Perimeters, Surface Areas and Area-to-Perimeter Ratios for Round Hollow Structural Sections . . . . .	83
Table 6c	Surface and Box Perimeters, Surface Areas and Area-to-Perimeter Ratios for Pipes . . . . .	87

**LIST OF FIGURES**

Figure 1	Shape and Box Perimeters . . . . .	88
----------	------------------------------------	----



## INTRODUCTION

The purpose of the Materials Section is to give the designer a ready source of dimensional and materials information to aid in developing details around structural members. Much of the materials information and tables in this section was extracted from Parts 1 and 2 of the 3<sup>rd</sup> Edition *Load and Resistance Factor Design Manual*.

The tensile group classification of structural shapes is given in Table 1. Applicable ASTM (American Society for Testing and Materials) specifications for structural shapes are given in Table 2; Table 3 contains applicable ASTM specifications for plates and bars. For complete information on each material, reference should be made to the appropriate ASTM specification.

Dimensional information is available in Tables 4a-4m in both U.S. customary and metric units for each of the shapes discussed in this Guide. Note that dimensional information for double angles are not given directly but can be obtained by reviewing the data given for single angles in Table 4g. Similarly, only limited dimensional information for WT-, MT-, and ST-shapes are given in Tables 4k-4m since additional dimensional information can be found in the table for the shape from which the tee is split.

Surface and box perimeters, surface areas and weight/perimeter (W/D) ratios are given in Tables 5a-5j for each of the shapes (excluding hollow structural sections and pipes) discussed in this section. Surface and box perimeters, surface areas and area/perimeter ratios are given in Tables 6a-6c for hollow structural sections and pipes.

### Availability Listings for Structural Shapes

The latest availability listings of structural steel shapes (including hollow structural sections) are printed in the January or July issue of *Modern Steel Construction* and can also be viewed online at [www.aisc.org](http://www.aisc.org). The contact information for many of the principal producers is also given. It is strongly suggested that availability be confirmed with the producer, as availability can vary. The reader is encouraged to visit AISC's web site periodically and insert printouts of the latest availability listings at the end of this section.

## W-, S-, C-, MC-, HP-, M-SHAPES AND ANGLES

### General

W-shapes have essentially parallel inner and outer flange surfaces. The profile of a W-shape of a given nominal depth and weight available from different producers is essentially the same except for the size of fillets between the web and flanges. S-shapes (American standard beams) and C-shapes (American standard channels) have a slope of approximately  $16\frac{2}{3}$  percent (2 on 12) on the inner flange surfaces. The profiles of S- and C-shapes of a given nominal depth and weight available from different producers are essentially the same. MC-shapes (miscellaneous channels) have a different slope on the inner flange surfaces. HP-shapes (bearing piles) are similar to W-shapes, except their webs and flanges are of equal thickness and the depth and flange width are nominally equal for a given designation. The profile of an HP-shape of a given nominal depth and weight available from different producers is essentially the same. M-shapes are shapes that are not classified in ASTM A6 as W-, S- or HP-shapes. Angles (L-shapes) have legs of equal thickness and either equal or unequal leg sizes. Equal leg and unequal leg angles of the same nominal size available from different producers have profiles which are essentially the same, except for the size of fillet between the legs and the shape of the end of the legs.

Dimensional information for each of the shapes discussed in this section is found in Tables 4a-4g.



## Designation

W-, M-, S-, C-, MC-, and HP-shapes are designated by mark, nominal depth (in.) and nominal weight (lbs/ft). For example, a W24x55 is a W-shape that is nominally 24-in. deep and weighs 55 lbs/ft. Angles are designated by the mark "L", leg sizes (in.) and thickness (in.). For example, an L4x3x½ is an angle with one 4-in. leg, one 3-in. leg and ½-in. thickness.

## Dimensional Tolerances

Acceptable dimensional tolerances for the shapes discussed in this section are given in ASTM A6 Section 13. Supplementary information can also be found in literature from structural shape producers and the Iron and Steel Society, a division of the American Institute of Mining, Metallurgical and Petroleum Engineers.

## Specifying Material for W-Shapes

As shown in Table 2, the preferred material specification for W-shapes is ASTM A992. The availability of W-shapes in grades other than ASTM A992 should be confirmed prior to their specification. W-shapes with higher yield and tensile strength can be obtained by specifying ASTM A572 (grades 60 or 65, which cover tensile groups 1, 2 and 3 [see Table 1 for tensile group classifications] W-shapes only) or ASTM A913 (grades 60, 65 or 70). W-shapes with atmospheric corrosion resistance (weathering) characteristics can be obtained by specifying ASTM A588 (grade 50) or ASTM A242 (grade 42, which covers tensile group 4 and 5 shapes only; grade 46, which covers tensile group 3 shapes only; or grade 50, which covers tensile group 1 and 2 shapes only). Other material specifications applicable to W-shapes include ASTM A36, ASTM A529 (grades 50 or 55, which cover tensile groups 1 and 2 W-shapes only), ASTM A572 (grades 42 or 50), and ASTM A913 (grade 50).

## Specifying Material for M-, S-, C- and MC- Shapes

As shown in Table 2, the preferred material specification for M-, S-, C- and MC- shapes is ASTM A36, although ASTM A572 grade 50 is increasingly very common. These shapes with higher yield and tensile strength can be obtained by specifying ASTM A572 (grades 42, 50, 55, 60 or 65) or ASTM A529 (grades 50 or 55). Note that although ASTM A913 is an applicable material designation for these shapes, it is only currently available in W-shapes. M-, S-, C- and MC- shapes with atmospheric corrosion resistance (weathering) characteristics can be obtained by specifying ASTM A588 (grade 50) or ASTM A242 (grade 50). The availability of these shapes in grades other than ASTM A36 should be confirmed prior to their specification. Additionally, because many of the M- and MC-shapes are only available from a limited number of producers or are infrequently rolled, their availability should be checked before specifying these shapes.

## Specifying Material for HP-Shapes

The preceding comments for M-, S-, C- and MC- shapes apply equally to HP-shapes, except that ASTM A529 (grades 50 or 55) and ASTM A242 (grade 50) are applicable to tensile group 2 (see Table 1 for tensile group classifications) HP-shapes only, and tensile group 3 HP-shapes with atmospheric corrosion resistance (weathering) characteristics can also be obtained by specifying ASTM A242 (grade 46).





## Specifying Material for Angles

As shown in Table 2, the preferred material specification for angles is ASTM A36. The availability of angles in grades other than ASTM A36 should be confirmed prior to their specification. Angles with higher yield and tensile strength can be obtained by specifying ASTM A572 (grades 42, 50, 55, 60 or 65) or ASTM A529 (grades 50 or 55, which cover tensile groups 1 and 2 (see Table 1 for tensile group classifications) angles only). Note that although ASTM A913 is an applicable material designation for angles, it is currently only available in W-shapes. Angles with atmospheric corrosion resistance (weathering) characteristics can be obtained by specifying ASTM A588 (grade 50) or ASTM A242 (grade 46, which covers tensile group 3 angles only, or grade 50, which covers tensile group 1 and 2 angles only). Availability of certain angles is subject to rolling accumulation and geographical location and should be checked with material suppliers.

## STRUCTURAL TEES (WT-, MT- AND ST- SHAPES)

### General and Designation

These shapes are designated by the mark WT, MT or ST, nominal depth (in.) and nominal weight (lbs/ft). WT-, MT- and ST-shapes are split (sheared or flame-cut) from W-, M- and S-shapes, respectively, and have half the nominal depth and weight of that shape. For example, a WT12×27.5 is a structural tee split from a W-shape (W24×55), is nominally 12 in. deep and weighs 27.5 lbs/ft. A summary of tees and the shape that they were split from is found in Tables 4k-4m.

### Specifying Material for Structural Tees

For the preferred material specifications, as well as other suitable material specifications, for structural tees, refer to the preceding discussions in the sections on W-, M- or S-shapes, as appropriate.

## HOLLOW STRUCTURAL SECTIONS (HSS) AND PIPE

### General

Rectangular (including square) HSS have an essentially rectangular (or square) cross-section, except for rounded corners, and also have a uniform wall thickness, except at the weld seam(s). Both round HSS and pipes have an essentially round cross-section and uniform wall thickness ( $t$ ), except at the weld seam(s).

For rectangular HSS, the outside corner radii are taken as  $2t$  for electric resistance welded (ERW) HSS, except that a centerline corner radius of  $1.5t$  is used in all cases in the calculation of width-to-thickness ratios.

Dimensional information for HSS and pipe is located in Tables 4h-4j.

### Designation

Rectangular HSS are designated by the mark "HSS", overall outside dimensions (in.) and wall thickness (in.), with all dimensions expressed as fractional numbers. For example, an HSS10×10× $\frac{1}{2}$  is nominally 10 in. by 10 in. with



a ½-in. wall thickness. Round HSS are designated by the term "HSS", nominal outside diameter (in.) and wall thickness (in.) with both dimensions expressed to three decimal places. For example, an HSS10.000×0.500 is nominally 10-in. in diameter with a ½-in. nominal wall thickness. Some round HSS are configured to match the dimensional characteristics of steel pipe, such as an HSS5.563×0.258, which is the dimensional equivalent of a Pipe 5 Std. steel pipe. Steel pipes up to and including NPS 12 are designated by the term "Pipe", nominal diameter (in.) and weight class (Std., x-strong, xx-strong). NPS stands for "nominal pipe size". For example, Pipe 5 Std. denotes a steel pipe with a 5-in. nominal diameter and a 0.258-in. wall thickness, which corresponds to the standard weight series. Steel pipes with wall thicknesses that do not correspond to the foregoing weight classes are designated by the term "Pipe", outside diameter (in.) and wall thickness (in.) with both expressed to three decimal places. For example, Pipe 14.000×0.375 and Pipe 5.563×0.500 are proper designations.

### Specifying Material for HSS and Pipe

As shown in Table 2, the preferred material specification for round and rectangular (and square) HSS is ASTM A500 grade B, although ASTM A500 grade C is increasingly very common. The availability of HSS in grades other than ASTM A500 grade B should be confirmed prior to their specification. HSS with atmospheric corrosion resistance (weathering) characteristics can be obtained by specifying ASTM A847. Other material specifications applicable to HSS include ASTM A501 and ASTM A618. The sole material specification for steel pipe is ASTM A53 grade B.

### Dimensional Tolerances

Acceptable dimensional tolerances for HSS are given in ASTM A500 Section 10, A501 Section 11, A618 Section 8 or A847 Section 10, as applicable. Supplementary information can also be found in literature from HSS producers and the Steel Tube Institute, such as *Recommended Methods to Check Dimensional Tolerances on Hollow Structural Sections (HSS) Made to ASTM A500* (available at [www.steeltubeinstitute.org](http://www.steeltubeinstitute.org)). Acceptable dimensional tolerances for steel pipes are given in ASTM A53 Section 12. Supplementary information can also be found in literature from steel pipe producers.

## PLATES AND BARS

### General

The historical classification system for structural bars and plates suggests that there is only a physical difference between them based upon size and production procedure. In raw form, flat stock has historically been classified as a bar if it is less than or equal to 8 in. wide and as a plate if it is greater than 8 in. wide. Bars are rolled between horizontal and vertical rolls and trimmed to length by shearing or flame cutting on the ends only. Plates are generally produced using one of three methods:

1. Sheared plates are rolled between horizontal rolls and trimmed to width and length by shearing or flame cutting on the edges and ends;
2. Universal mill (UM) plates are rolled between horizontal and vertical rolls and trimmed to length by shearing or flame cutting on the ends only; and,
3. Stripped plates are sheared or flame cut from wider sheared plates.



## Specifying Thickness

There is very little, if any, structural difference between plates and bars. Consequently, the term "plate" is becoming a universally applied term today and a PL $\frac{1}{2}$   $\times$  4 $\frac{1}{2}$   $\times$  1'-3", for example, might be fabricated from plate or bar stock. For structural plates, the preferred practice is to specify thickness in  $\frac{1}{16}$ -in. increments up to  $\frac{3}{8}$ -in. thickness,  $\frac{1}{8}$ -in. increments over  $\frac{3}{8}$ -in. to 1-in. thickness and  $\frac{1}{4}$ -in. increments over 1-in. thickness. The current extreme widths for sheared and UM plates are 200 in. and 60 in., respectively. Because mill practices regarding plate widths vary, individual mills should be consulted to determine preferences. For bars, the preferred practice is to specify width in  $\frac{1}{4}$ -in. increments and thickness and diameter in  $\frac{1}{8}$ -in. increments.

## Dimensional Tolerances

Acceptable dimensional tolerances for plate products are given in ASTM A6 Section 13. Note that plate thickness can be specified in inches or by weight per square foot, and separate tolerances apply to each method. No decimal edge thickness can be assured for plate specified by the latter method. Supplementary information, including permissible variations for sheet and strip and for other grades of steel, can also be found in literature from steel plate producers and the Iron and Steel Society, a division of the American Institute of Mining, Metallurgical and Petroleum Engineers.

## Specifying Material for Plates and Bars

As shown in Table 3, the preferred material specification for structural plates is ASTM A36. The availability and cost effectiveness of structural plates in grades other than ASTM A36 should be confirmed prior to their specification. Note also that the availability of grades other than ASTM A36 varies through the range of thickness. Structural plates with higher yield and tensile strengths or atmospheric corrosion resistance (weathering) characteristics can be obtained by specifying ASTM A572, ASTM A529, ASTM A514, ASTM A852, ASTM A588 or ASTM A242. Table 3 shows the appropriate grades of material to specify for each of these materials. The preceding comments for structural plates apply equally to structural bars, except that neither ASTM A514 nor ASTM A852 are applicable.



**Table 1**

Tensile Group Classification of Structural Shapes<sup>a</sup>

Shape	Group 1	Group 2	Group 3	Group 4 <sup>b</sup>	Group 5 <sup>b</sup>	
<b>W-Shapes</b>	W44x	--	--	230 to 290	335	--
	W40x	--	149 to 264	277 to 327	331 to 593	--
	W36x	--	135 to 210	230 to 300	328 to 798	--
	W33x	--	118 to 152	169 to 291	318 to 387	--
	W30x	--	90 to 211	235, 261	292 to 391	--
	W27x	--	84 to 178	194 to 258	281 to 539	--
	W24x	55, 62	68 to 162	176 to 229	250 to 370	--
	W21x	44 to 57	62 to 147	166 to 201	--	--
	W18x	35 to 71	76 to 143	158, 175	--	--
	W16x	26 to 57	67 to 100	--	--	--
	W14x	22 to 53	61 to 132	145 to 211	233 to 550	605 to 808
	W12x	14 to 58	65 to 106	120 to 190	210 to 336	--
	W10x	12 to 45	49 to 112	--	--	--
	W8x	10 to 48	58, 67	--	--	--
	W6x	8.5 to 25	--	--	--	--
	W5x	16, 19	--	--	--	--
W4x	13	--	--	--	--	
<b>M-Shapes</b>	all	--	--	--	--	
<b>S-Shapes</b>	to 35 lb/ft incl.	over 35 lb/ft	--	--	--	
<b>HP-Shapes</b>	--	to 102 lb/ft incl.	over 102 lb/ft	--	--	
<b>American Standard Channels (C)</b>	to 20.7 lb/ft incl.	over 20.7 lb/ft	--	--	--	
<b>Miscellaneous Channels (MC)</b>	to 28.5 lb/ft incl.	over 28.5 lb/ft	--	--	--	
<b>Angles (L)</b>	to 1/2-in. incl.	over 1/2 in. to 3/4 in. incl.	over 3/4 in.	--	--	
<b>Structural Tees (WT, MT, ST)</b>	Structural tees cut from W-, M-, and S-shapes fall into the same group as the structural shapes from which they are cut.					
-- indicates that tensile group number does not apply to that shape or shape range.						
<sup>a</sup> This table has been adjusted from the similar table in ASTM A6 to include all shapes listed in ASTM A6 Tables A2.1 through A2.8.						
<sup>b</sup> Special requirements may apply, per LRFD Specification Section A3.1c.						

**Table 2**  
Applicable ASTM Specifications for Various Structural Shapes

Steel Type	ASTM Designation	$F_y$ Min. Yield Stress (ksi)	$F_u$ Tensile Stress <sup>a</sup> (ksi)	Applicable Shape Series								HSS		Steel Pipe	
				W	M	S	HP	C	MC	L	Rect.	Round			
Carbon	A36	36	58-80 <sup>b</sup>	■	■	■	■	■	■	■	■	■	■	■	
	A53 Gr. B	35	60											■	
	A500	Gr. B	42	58											■
			46	58								■			
		Gr. C	46	62											■
	50		62											■	
	A501	36	58											■	
A529 <sup>c</sup>	Gr. 50	50	65-100												
	Gr. 55	55	70-100												
High-Strength Low-Alloy	A572	Gr. 42	42	60											
		Gr. 50	50	65 <sup>d</sup>											
		Gr. 55	55	70											
		Gr. 60 <sup>e</sup>	60	75											
		Gr. 65 <sup>e</sup>	65	80											
	A618 <sup>f</sup>	Gr. I & II	50 <sup>g</sup>	70 <sup>g</sup>											
		Gr. III	50	65											
	A913	50	50 <sup>h</sup>	60 <sup>h</sup>											
		60	60	75											
		65	65	80											
70		70	90												
A992	50-65 <sup>i</sup>	65 <sup>i</sup>	■												
Corrosion Resistant High- Strength Low- Alloy	A242	42 <sup>j</sup>	63 <sup>j</sup>												
		46 <sup>k</sup>	67 <sup>k</sup>												
		50 <sup>l</sup>	70 <sup>l</sup>												
	A588	50	70												
	A847 <sup>l</sup>	50	70												

■ = Preferred material specification.

■ = Other applicable material specification, the availability of which should be confirmed prior to specification.

□ = Material specification does not apply.

<sup>a</sup> Minimum unless a range is shown.

<sup>b</sup> For shapes over 426 lb/ft, only the minimum of 58 ksi applies.

<sup>c</sup> Groups 1 and 2 shapes only. To improve weldability a maximum carbon equivalent can be specified (per ASTM Supplementary Requirement S78). If desired, maximum tensile stress of 90 ksi can be specified (per ASTM Supplementary Requirement S79).

<sup>d</sup> If desired, maximum tensile stress of 70 ksi can be specified (per ASTM Supplementary Requirement S91).

<sup>e</sup> Groups 1, 2 and 3 shapes only.

<sup>f</sup> ASTM A618 can also be specified as corrosion-resistant; see ASTM A618.

<sup>g</sup> Minimum applies for walls nominally 3/4-in. thick and under. For wall thicknesses over 3/4 in.,  $F_y = 46$  ksi and  $F_u = 67$  ksi.

<sup>h</sup> If desired, maximum yield stress of 65 ksi and maximum yield-to-tensile strength ratio of 0.85 can be specified (per ASTM Supplementary Requirement S75).

<sup>i</sup> A maximum yield-to-tensile strength ratio of 0.85 and carbon equivalent formula are included as mandatory in ASTM A992.

<sup>j</sup> Groups 4 and 5 shapes only.

<sup>k</sup> Group 3 shapes only.

<sup>l</sup> Groups 1 and 2 shapes only.



**Table 3**

Applicable ASTM Specifications for Plates and Bars

Steel Type	ASTM Designation	$F_y$ Min. Yield Stress (ksi)	$F_u$ Tensile Stress <sup>a</sup> (ksi)	Plates and Bars (thickness in inches)										
				to 0.75 incl.	over 0.75 to 1.25 incl.	over 1.25 to 1.5 incl.	over 1.5 to 2 incl.	over 2 to 2.5 incl.	over 2.5 to 4 incl.	over 4 to 5 incl.	over 5 to 6 incl.	over 6 to 8 incl.	over 8	
Carbon	A36	32	58-80											
		36	58-80											
	A529	Gr. 50	50	70-100		b	b	b	b					
		Gr. 55	55	70-100		b	b							
High-Strength Low-Alloy	A572	Gr. 42	42	60										
		Gr. 50	50	65										
		Gr. 55	55	70										
		Gr. 60	60	75										
		Gr. 65	65	80										
Corrosion Resistant High-Strength Low-Alloy	A242	42	63											
		46	67											
		50	70											
	A588	42	63											
46		67												
50		70												
Quenched and Tempered Alloy	A514 <sup>c</sup>	90	100-130											
		100	110-130											
Quenched and Tempered Low-Alloy	A852 <sup>c</sup>	70	90-110											

= Preferred material specification.

= Other applicable material specification, the availability of which should be confirmed prior to specification.

= Material specification does not apply.

<sup>a</sup> Minimum unless a range is shown.

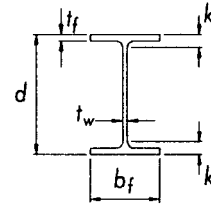
<sup>b</sup> Applicable to bars only above 1-in. thickness.

<sup>c</sup> Available as plates only.



**Table 4a**

Dimensions for W-Shapes



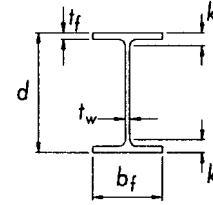
U.S. Customary Units					
Designation	Depth	Web	Flange		Distance
nominal depth (in) x nominal weight (lb/ft)	d (in)	thick- ness t <sub>w</sub> (in)	width b <sub>f</sub> (in)	thick- ness t <sub>f</sub> (in)	k (in)
W44X335	44.0	1.02	16.0	1.77	2- 5/8
X290	43.6	0.87	15.8	1.58	2- 7/16
X262	43.3	0.79	15.8	1.42	2- 1/4
X230	42.9	0.71	15.8	1.22	2- 1/16
W40X593	43.0	1.79	16.7	3.23	4- 1/2
X503	42.1	1.54	16.4	2.76	4
X431	41.3	1.34	16.2	2.36	3- 5/8
X397	41.0	1.22	16.1	2.20	3- 1/2
X372	40.6	1.16	16.1	2.05	3- 5/16
X362	40.6	1.12	16.0	2.01	3- 1/4
X324	40.2	1.00	15.9	1.81	3- 1/16
X297	39.8	0.93	15.8	1.65	2-15/16
X277	39.7	0.83	15.8	1.58	2- 7/8
X249	39.4	0.75	15.8	1.42	2-11/16
X215	39.0	0.65	15.8	1.22	2- 1/2
X199	38.7	0.65	15.8	1.07	2- 5/16
X392	41.6	1.42	12.4	2.52	3-13/16
X331	40.8	1.22	12.2	2.13	3- 3/8
X327	40.8	1.18	12.1	2.13	3- 3/8
X278	40.2	1.02	12.0	1.81	3- 1/16
X264	40.0	0.96	11.9	1.73	3
X235	39.7	0.83	11.9	1.58	2- 7/8
X211	39.4	0.75	11.8	1.42	2-11/16
X183	39.0	0.65	11.8	1.22	2- 1/2
X167	38.6	0.65	11.8	1.02	2- 5/16
X149	38.2	0.63	11.8	0.83	2- 1/8
W36X798	42.0	2.38	18.0	4.29	5- 9/16
X650	40.5	1.97	17.6	3.54	4-13/16
X527	39.2	1.61	17.2	2.91	4- 3/16
X439	38.3	1.36	17.0	2.44	3-11/16
X393	37.8	1.22	16.8	2.20	3- 7/16
X359	37.4	1.12	16.7	2.01	3- 1/4
X328	37.1	1.02	16.6	1.85	3- 1/8
X300	36.7	0.95	16.7	1.68	2-15/16
X280	36.5	0.89	16.6	1.57	2-13/16
X260	36.3	0.84	16.6	1.44	2-11/16
X245	36.1	0.80	16.5	1.35	2- 5/8
X230	35.9	0.76	16.5	1.26	2- 1/2
X256	37.4	0.96	12.2	1.73	2- 5/8

Metric Units					
Designation	Depth	Web	Flange		Distance
nominal depth (mm) x nominal weight (kg/m)	d (mm)	thick- ness t <sub>w</sub> (mm)	width b <sub>f</sub> (mm)	thick- ness t <sub>f</sub> (mm)	k (mm)
W1100X499	1118	25.9	405	45.0	67
X433	1108	22.1	402	40.1	62
X390	1100	20.1	400	36.1	58
X343	1090	18.0	400	31.0	53
W1000X883	1092	45.5	424	82.0	114
X748	1068	39.1	417	70.1	102
X642	1048	34.0	412	59.9	92
X591	1040	31.0	409	55.9	88
X554	1032	29.5	408	52.1	84
X539	1030	28.4	407	51.1	83
X483	1020	25.4	404	46.0	78
X443	1012	23.6	402	41.9	74
X412	1008	21.1	402	40.0	72
X371	1000	19.1	400	36.1	68
X321	990	16.5	400	31.0	63
X296	982	16.5	400	27.1	59
X584	1056	36.1	314	64.0	96
X494	1036	31.0	309	54.0	86
X486	1036	30.0	308	54.1	86
X415	1020	25.9	304	46.0	78
X393	1016	24.4	303	43.9	76
X350	1008	21.1	302	40.0	72
X314	1000	19.1	300	35.9	68
X272	990	16.5	300	31.0	63
X249	980	16.5	300	26.0	58
X222	970	16.0	300	21.1	53
W920X1188	1066	60.5	457	109.0	141
X967	1028	50.0	446	89.9	122
X784	996	40.9	437	73.9	106
X653	972	34.5	431	62.0	94
X585	960	31.0	427	55.9	88
X534	950	28.4	425	51.1	83
X488	942	25.9	422	47.0	79
X446	933	24.0	423	42.7	74
X417	928	22.5	422	39.9	72
X387	921	21.3	420	36.6	68
X365	916	20.3	419	34.3	66
X342	912	19.3	418	32.0	64
X381	951	24.4	310	43.9	66



**Table 4a (Continued)**

Dimensions for W-Shapes



U.S. Customary Units					
Designation	Depth	Web	Flange		Distance
nominal depth (in) x nominal weight (lb/ft)	<i>d</i> (in)	thick- ness <i>t<sub>w</sub></i> (in)	width <i>b<sub>f</sub></i> (in)	thick- ness <i>t<sub>f</sub></i> (in)	<i>k</i> (in)
W36X232	37.1	0.87	12.1	1.57	2- 7/16
X210	36.7	0.83	12.2	1.36	2- 5/16
X194	36.5	0.77	12.1	1.26	2- 3/16
X182	36.3	0.73	12.1	1.18	2- 1/8
X170	36.2	0.68	12.0	1.10	2
X160	36.0	0.65	12.0	1.02	1-15/16
X150	35.9	0.63	12.0	0.94	1- 7/8
X135	35.6	0.60	12.0	0.79	1-11/16
W33X387	36.0	1.26	16.2	2.28	3- 3/16
X354	35.6	1.16	16.1	2.09	2-15/16
X318	35.2	1.04	16.0	1.89	2- 3/4
X291	34.8	0.96	15.9	1.73	2- 5/8
X263	34.5	0.87	15.8	1.57	2- 7/16
X241	34.2	0.83	15.9	1.40	2- 1/4
X221	33.9	0.78	15.8	1.27	2- 1/8
X201	33.7	0.72	15.7	1.15	2
X169	33.8	0.67	11.5	1.22	2- 1/8
X152	33.5	0.64	11.6	1.06	1-15/16
X141	33.3	0.61	11.5	0.96	1-13/16
X130	33.1	0.58	11.5	0.86	1- 3/4
X118	32.9	0.55	11.5	0.74	1- 5/8
W30X391	33.2	1.36	15.6	2.44	3- 3/8
X357	32.8	1.24	15.5	2.24	3- 1/8
X326	32.4	1.14	15.4	2.05	2-15/16
X292	32.0	1.02	15.3	1.85	2- 3/4
X261	31.6	0.93	15.2	1.65	2- 9/16
X235	31.3	0.83	15.1	1.50	2- 3/8
X211	30.9	0.78	15.1	1.32	2- 1/4
X191	30.7	0.71	15.0	1.19	2- 1/16
X173	30.4	0.66	15.0	1.07	2
X148	30.7	0.65	10.5	1.18	2- 1/16
X132	30.3	0.62	10.5	1.00	1- 7/8
X124	30.2	0.59	10.5	0.93	1-13/16
X116	30.0	0.57	10.5	0.85	1- 3/4
X108	29.8	0.55	10.5	0.76	1-11/16
X99	29.7	0.52	10.5	0.67	1- 9/16
X90	29.5	0.47	10.4	0.61	1- 1/2
W27X539	32.5	1.97	15.3	3.54	4- 7/16
X368	30.4	1.38	14.7	2.48	3- 3/8

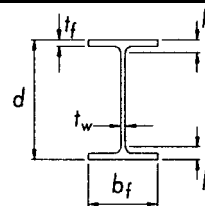
Metric Units					
Designation	Depth	Web	Flange		Distance
nominal depth (mm) x nominal weight (kg/m)	<i>d</i> (mm)	thick- ness <i>t<sub>w</sub></i> (mm)	width <i>b<sub>f</sub></i> (mm)	thick- ness <i>t<sub>f</sub></i> (mm)	<i>k</i> (mm)
W920X345	943	22.1	308	39.9	62
X313	932	21.1	309	34.5	57
X289	927	19.4	308	32.0	54
X271	923	18.4	307	30.0	52
X253	919	17.3	306	27.9	50
X238	915	16.5	305	25.9	48
X223	911	15.9	304	23.9	46
X201	903	15.2	304	20.1	42
W840X576	913	32.0	411	57.9	80
X527	903	29.5	409	53.1	75
X473	893	26.4	406	48.0	70
X433	885	24.4	404	43.9	66
X392	877	22.1	401	39.9	62
X359	868	21.1	403	35.6	57
X329	862	19.7	401	32.4	54
X299	855	18.2	400	29.2	51
X251	859	17.0	292	31.0	53
X226	851	16.1	294	26.8	49
X210	846	15.4	293	24.4	47
X193	840	14.7	292	21.7	44
X176	835	14.0	292	18.8	41
W760X582	843	34.5	396	62.0	84
X531	833	31.5	393	56.9	79
X484	823	29.0	390	52.1	74
X434	813	25.9	387	47.0	69
X389	803	23.6	385	41.9	64
X350	795	21.1	382	38.1	60
X314	786	19.7	384	33.4	55
X284	779	18.0	382	30.1	52
X257	773	16.6	381	27.1	49
X220	779	16.5	266	30.0	52
X196	770	15.6	268	25.4	48
X185	766	14.9	267	23.6	46
X173	762	14.4	267	21.6	44
X161	758	13.8	266	19.3	42
X147	753	13.2	265	17.0	39
X134	750	11.9	264	15.5	38
W690X802	826	50.0	387	89.9	112
X548	772	35.1	372	63.0	85





**Table 4a (Continued)**

Dimensions for W-Shapes

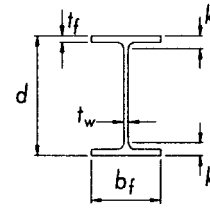


U.S. Customary Units					
Designation	Depth	Web	Flange		Distance
nominal depth (in)		thick- ness	width	thick- ness	
x nominal weight (lb/ft)	<i>d</i> (in)	<i>t<sub>w</sub></i> (in)	<i>b<sub>f</sub></i> (in)	<i>t<sub>f</sub></i> (in)	<i>k</i> (in)
W27X336	30.0	1.26	14.6	2.28	3- 3/16
X307	29.6	1.16	14.4	2.09	3
X281	29.3	1.06	14.4	1.93	2-13/16
X258	29.0	0.98	14.3	1.77	2-11/16
X235	28.7	0.91	14.2	1.61	2- 1/2
X217	28.4	0.83	14.1	1.50	2- 3/8
X194	28.1	0.75	14.0	1.34	2- 1/4
X178	27.8	0.73	14.1	1.19	2- 1/16
X161	27.6	0.66	14.0	1.08	2
X146	27.4	0.61	14.0	0.98	1- 7/8
X129	27.6	0.61	10.0	1.10	2
X114	27.3	0.57	10.1	0.93	1-13/16
X102	27.1	0.52	10.0	0.83	1- 3/4
X94	26.9	0.49	10.0	0.75	1- 5/8
X84	26.7	0.46	10.0	0.64	1- 9/16
W24X370	28.0	1.52	13.7	2.72	3- 5/8
X335	27.5	1.38	13.5	2.48	3- 3/8
X306	27.1	1.26	13.4	2.28	3- 3/16
X279	26.7	1.16	13.3	2.09	3
X250	26.3	1.04	13.2	1.89	2-13/16
X229	26.0	0.96	13.1	1.73	2- 5/8
X207	25.7	0.87	13.0	1.57	2- 1/2
X192	25.5	0.81	13.0	1.46	2- 3/8
X176	25.2	0.75	12.9	1.34	2- 1/4
X162	25.0	0.71	13.0	1.22	2- 1/8
X146	24.7	0.65	12.9	1.09	2
X131	24.5	0.61	12.9	0.96	1- 7/8
X117	24.3	0.55	12.8	0.85	1- 3/4
X104	24.1	0.50	12.8	0.75	1- 5/8
X103	24.5	0.55	9.0	0.98	1- 7/8
X94	24.3	0.52	9.1	0.88	1- 3/4
X84	24.1	0.47	9.0	0.77	1-11/16
X76	23.9	0.44	9.0	0.68	1- 9/16
X68	23.7	0.42	9.0	0.59	1- 1/2
X62	23.7	0.43	7.0	0.59	1- 1/2
X55	23.6	0.40	7.0	0.51	1- 7/16
W21X201	23.0	0.91	12.6	1.63	2- 1/2
X182	22.7	0.83	12.5	1.48	2- 3/8
X166	22.5	0.75	12.4	1.36	2- 1/4

Metric Units					
Designation	Depth	Web	Flange		Distance
nominal depth (mm)		thick- ness	width	thick- ness	
x nominal weight (kg/m)	<i>d</i> (mm)	<i>t<sub>w</sub></i> (mm)	<i>b<sub>f</sub></i> (mm)	<i>t<sub>f</sub></i> (mm)	<i>k</i> (mm)
W690X500	762	32.0	370	57.9	80
X457	752	29.5	367	53.1	75
X419	744	26.9	364	49.0	71
X384	736	24.9	362	45.0	67
X350	728	23.1	360	40.9	63
X323	722	21.1	359	38.1	60
X289	714	19.1	356	34.0	56
X265	706	18.4	358	30.2	52
X240	701	16.8	356	27.4	50
X217	695	15.4	355	24.8	47
X192	702	15.5	254	27.9	50
X170	693	14.5	256	23.6	46
X152	688	13.1	254	21.1	43
X140	684	12.4	254	18.9	41
X125	678	11.7	253	16.3	38
W610X551	711	38.6	347	69.1	91
X498	699	35.1	343	63.0	85
X455	689	32.0	340	57.9	80
X415	679	29.5	338	53.1	75
X372	669	26.4	335	48.0	70
X341	661	24.4	333	43.9	66
X307	653	22.1	330	39.9	62
X285	647	20.6	329	37.1	59
X262	641	19.1	327	34.0	56
X241	635	17.9	329	31.0	53
X217	628	16.5	328	27.7	50
X195	622	15.4	327	24.4	47
X174	616	14.0	325	21.6	44
X155	611	12.7	324	19.1	41
X153	623	14.0	229	24.9	47
X140	617	13.1	230	22.2	44
X125	612	11.9	229	19.6	42
X113	608	11.2	228	17.3	40
X101	603	10.5	228	14.9	37
X92	603	10.9	179	15.0	37
X82	599	10.0	178	12.8	35
W530X300	585	23.1	319	41.4	64
X272	577	21.1	318	37.6	60
X248	571	19.1	315	34.5	57



**Table 4a (Continued)**  
Dimensions for W-Shapes



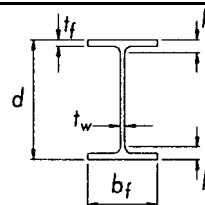
U.S. Customary Units					
Designation	Depth	Web	Flange		Distance
nominal depth (in) x nominal weight (lb/ft)	<i>d</i> (in)	thick- ness <i>t<sub>w</sub></i> (in)	width <i>b<sub>f</sub></i> (in)	thick- ness <i>t<sub>f</sub></i> (in)	<i>k</i> (in)
W21X147	22.1	0.72	12.5	1.15	2
X132	21.8	0.65	12.4	1.03	1-15/16
X122	21.7	0.60	12.4	0.96	1-13/16
X111	21.5	0.55	12.3	0.88	1- 3/4
X101	21.4	0.50	12.3	0.80	1-11/16
X93	21.6	0.58	8.4	0.93	1- 5/8
X83	21.4	0.52	8.4	0.84	1- 1/2
X73	21.2	0.46	8.3	0.74	1- 7/16
X68	21.1	0.43	8.3	0.69	1- 3/8
X62	21.0	0.40	8.2	0.62	1- 5/16
X55	20.8	0.38	8.2	0.52	1- 3/16
X48	20.6	0.35	8.1	0.43	1- 1/8
X57	21.1	0.41	6.6	0.65	1- 5/16
X50	20.8	0.38	6.5	0.54	1- 1/4
X44	20.7	0.35	6.5	0.45	1- 1/8
W18X175	20.0	0.89	11.4	1.59	2- 7/16
X158	19.7	0.81	11.3	1.44	2- 3/8
X143	19.5	0.73	11.2	1.32	2- 3/16
X130	19.3	0.67	11.2	1.20	2- 1/16
X119	19.0	0.66	11.3	1.06	1-15/16
X106	18.7	0.59	11.2	0.94	1-13/16
X97	18.6	0.54	11.1	0.87	1- 3/4
X86	18.4	0.48	11.1	0.77	1- 5/8
X76	18.2	0.43	11.0	0.68	1- 9/16
X71	18.5	0.50	7.6	0.81	1- 1/2
X65	18.4	0.45	7.6	0.75	1- 7/16
X60	18.2	0.42	7.6	0.70	1- 3/8
X55	18.1	0.39	7.5	0.63	1- 5/16
X50	18.0	0.36	7.5	0.57	1- 1/4
X46	18.1	0.36	6.1	0.61	1- 1/4
X40	17.9	0.32	6.0	0.53	1- 3/16
X35	17.7	0.30	6.0	0.43	1- 1/8
W16X100	17.0	0.59	10.4	0.99	1- 7/8
X89	16.8	0.53	10.4	0.88	1- 3/4
X77	16.5	0.46	10.3	0.76	1- 5/8
X67	16.3	0.40	10.2	0.67	1- 9/16
X57	16.4	0.43	7.1	0.72	1- 3/8
X50	16.3	0.38	7.1	0.63	1- 5/16
X45	16.1	0.35	7.0	0.57	1- 1/4

Metric Units					
Designation	Depth	Web	Flange		Distance
nominal depth (mm) x nominal weight (kg/m)	<i>d</i> (mm)	thick- ness <i>t<sub>w</sub></i> (mm)	width <i>b<sub>f</sub></i> (mm)	thick- ness <i>t<sub>f</sub></i> (mm)	<i>k</i> (mm)
W530X219	560	18.3	318	29.2	51
X196	554	16.5	316	26.3	48
X182	551	15.2	315	24.4	47
X165	546	14.0	313	22.2	44
X150	543	12.7	312	20.3	43
X138	549	14.7	214	23.6	41
X123	544	13.1	212	21.2	38
X109	539	11.6	211	18.8	36
X101	537	10.9	210	17.4	35
X92	533	10.2	209	15.6	33
X82	528	9.5	209	13.3	30
X72	524	8.9	207	10.9	28
X85	535	10.3	166	16.5	34
X74	529	9.7	166	13.6	31
X66	525	8.9	165	11.4	29
W460X260	509	22.6	289	40.4	63
X235	501	20.6	287	36.6	59
X213	495	18.5	285	33.5	56
X193	489	17.0	283	30.5	53
X177	482	16.6	286	26.9	49
X158	476	15.0	284	23.9	46
X144	472	13.6	283	22.1	44
X128	467	12.2	282	19.6	42
X113	463	10.8	280	17.3	40
X106	469	12.6	194	20.6	38
X97	466	11.4	193	19.1	36
X89	463	10.5	192	17.7	35
X82	460	9.9	191	16.0	33
X74	457	9.0	190	14.5	32
X68	459	9.1	154	15.4	33
X60	455	8.0	153	13.3	31
X52	450	7.6	152	10.8	28
W410X149	431	14.9	265	25.0	47
X132	425	13.3	263	22.2	44
X114	420	11.6	261	19.3	42
X100	415	10.0	260	16.9	39
X85	417	10.9	181	18.2	35
X75	413	9.7	180	16.0	33
X67	410	8.8	179	14.4	32



**Table 4a (Continued)**

Dimensions for W-Shapes



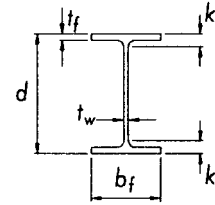
U.S. Customary Units					
Designation	Depth	Web	Flange		Distance
nominal depth (in)		thick- ness	width	thick- ness	
x nominal weight (lb/ft)	<i>d</i> (in)	<i>t<sub>w</sub></i> (in)	<i>b<sub>f</sub></i> (in)	<i>t<sub>f</sub></i> (in)	<i>k</i> (in)
W16X40	16.0	0.31	7.0	0.51	1- 3/16
X36	15.9	0.30	7.0	0.43	1- 1/8
X31	15.9	0.28	5.5	0.44	1- 1/8
X26	15.7	0.25	5.5	0.35	1- 1/16
W14X808	22.8	3.74	18.6	5.12	6- 7/16
X730	22.4	3.07	17.9	4.91	6- 3/16
X665	21.6	2.83	17.7	4.52	5-13/16
X605	20.9	2.60	17.4	4.16	5- 7/16
X550	20.2	2.38	17.2	3.82	5- 1/8
X500	19.6	2.19	17.0	3.50	4-13/16
X455	19.0	2.02	16.8	3.21	4- 1/2
X426	18.7	1.88	16.7	3.04	4- 5/16
X398	18.3	1.77	16.6	2.85	4- 1/8
X370	17.9	1.66	16.5	2.66	3-15/16
X342	17.5	1.54	16.4	2.47	3- 3/4
X311	17.1	1.41	16.2	2.26	3- 9/16
X283	16.7	1.29	16.1	2.07	3- 3/8
X257	16.4	1.18	16.0	1.89	3- 3/16
X233	16.0	1.07	15.9	1.72	3
X211	15.7	0.98	15.8	1.56	2- 7/8
X193	15.5	0.89	15.7	1.44	2- 3/4
X176	15.2	0.83	15.7	1.31	2- 5/8
X159	15.0	0.75	15.6	1.19	2- 1/2
X145	14.8	0.68	15.5	1.09	2- 3/8
X132	14.7	0.65	14.7	1.03	2- 5/16
X120	14.5	0.59	14.7	0.94	2- 1/4
X109	14.3	0.53	14.6	0.86	2- 3/16
X99	14.2	0.49	14.6	0.78	2- 1/16
X90	14.0	0.44	14.5	0.71	2
X82	14.3	0.51	10.1	0.86	1-11/16
X74	14.2	0.45	10.1	0.79	1- 5/8
X68	14.0	0.42	10.0	0.72	1- 9/16
X61	13.9	0.38	10.0	0.65	1- 1/2
X53	13.9	0.37	8.1	0.66	1- 1/2
X48	13.8	0.34	8.0	0.60	1- 7/16
X43	13.7	0.31	8.0	0.53	1- 3/8
X38	14.1	0.31	6.8	0.52	1- 1/4
X34	14.0	0.29	6.8	0.46	1- 3/16

Metric Units					
Designation	Depth	Web	Flange		Distance
nominal depth (mm)		thick- ness	width	thick- ness	
x nominal weight (kg/m)	<i>d</i> (mm)	<i>t<sub>w</sub></i> (mm)	<i>b<sub>f</sub></i> (mm)	<i>t<sub>f</sub></i> (mm)	<i>k</i> (mm)
W410X60	407	7.7	178	12.8	30
X53	403	7.5	177	10.9	28
X46.1	403	7.0	140	11.2	28
X38.8	399	6.4	140	8.8	26
W360X1202	580	95.0	471	130.0	162
X1086	569	78.0	454	125.0	156
X990	550	71.9	448	115.0	147
X900	531	65.9	442	106.0	137
X818	514	60.5	437	97.0	129
X744	498	55.6	432	88.9	121
X677	483	51.2	428	81.5	113
X634	474	47.6	424	77.1	109
X592	465	45.0	421	72.3	104
X551	455	42.0	418	67.6	99
X509	446	39.1	416	62.7	95
X463	435	35.8	412	57.4	89
X421	425	32.8	409	52.6	84
X382	416	29.8	406	48.0	80
X347	407	27.2	404	43.7	75
X314	399	24.9	401	39.6	71
X287	393	22.6	399	36.6	68
X262	387	21.1	398	33.3	65
X237	380	18.9	395	30.2	62
X216	375	17.3	394	27.7	59
X196	372	16.4	374	26.2	58
X179	368	15.0	373	23.9	56
X162	364	13.3	371	21.8	54
X147	360	12.3	370	19.8	52
X134	356	11.2	369	18.0	50
X122	363	13.0	257	21.7	44
X110	360	11.4	256	19.9	42
X101	357	10.5	255	18.3	41
X91	353	9.5	254	16.4	39
X79	354	9.4	205	16.8	39
X72	350	8.6	204	15.1	37
X64	347	7.7	203	13.5	36
X57.8	358	7.9	172	13.1	30
X51	355	7.2	171	11.6	29



**Table 4a (Continued)**

Dimensions for W-Shapes



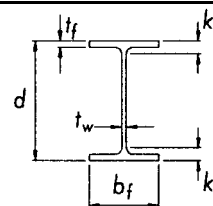
U.S. Customary Units					
Designation	Depth	Web	Flange		Distance
nominal depth (in) x nominal weight (lb/ft)	<i>d</i> (in)	thick- ness <i>t<sub>w</sub></i> (in)	width <i>b<sub>f</sub></i> (in)	thick- ness <i>t<sub>f</sub></i> (in)	<i>k</i> (in)
W14X30	13.8	0.27	6.7	0.39	1- 1/8
X26	13.9	0.26	5.0	0.42	1- 1/8
X22	13.7	0.23	5.0	0.34	1- 1/16
W12X336	16.8	1.78	13.4	2.96	3- 7/8
X305	16.3	1.63	13.2	2.71	3- 5/8
X279	15.9	1.53	13.1	2.47	3- 3/8
X252	15.4	1.40	13.0	2.25	3- 1/8
X230	15.1	1.29	12.9	2.07	2-15/16
X210	14.7	1.18	12.8	1.90	2-13/16
X190	14.4	1.06	12.7	1.74	2- 5/8
X170	14.0	0.96	12.6	1.56	2- 7/16
X152	13.7	0.87	12.5	1.40	2- 5/16
X136	13.4	0.79	12.4	1.25	2- 1/8
X120	13.1	0.71	12.3	1.11	2
X106	12.9	0.61	12.2	0.99	1- 7/8
X96	12.7	0.55	12.2	0.90	1-13/16
X87	12.5	0.52	12.1	0.81	1-11/16
X79	12.4	0.47	12.1	0.74	1- 5/8
X72	12.3	0.43	12.0	0.67	1- 9/16
X65	12.1	0.39	12.0	0.61	1- 1/2
X58	12.2	0.36	10.0	0.64	1- 1/2
X53	12.1	0.35	10.0	0.58	1- 3/8
X50	12.2	0.37	8.1	0.64	1- 1/2
X45	12.1	0.34	8.1	0.58	1- 3/8
X40	11.9	0.30	8.0	0.52	1- 3/8
X35	12.5	0.30	6.6	0.52	1- 3/16
X30	12.3	0.26	6.5	0.44	1- 1/8
X26	12.2	0.23	6.5	0.38	1- 1/16
X22	12.3	0.26	4.0	0.43	15/16
X19	12.2	0.24	4.0	0.35	7/8
X16	12.0	0.22	4.0	0.27	13/16
X14	11.9	0.20	4.0	0.23	3/4
W10X112	11.4	0.76	10.4	1.25	1-15/16
X100	11.1	0.68	10.3	1.12	1-13/16
X88	10.8	0.61	10.3	0.99	1-11/16
X77	10.6	0.53	10.2	0.87	1- 9/16
X68	10.4	0.47	10.1	0.77	1- 7/16
X60	10.2	0.42	10.1	0.68	1- 3/8
X54	10.1	0.37	10.0	0.62	1- 5/16

Metric Units					
Designation	Depth	Web	Flange		Distance
nominal depth (mm) x nominal weight (kg/m)	<i>d</i> (mm)	thick- ness <i>t<sub>w</sub></i> (mm)	width <i>b<sub>f</sub></i> (mm)	thick- ness <i>t<sub>f</sub></i> (mm)	<i>k</i> (mm)
W360X44	352	6.9	171	9.8	27
X39	353	6.5	128	10.7	28
X32.9	349	5.8	127	8.5	26
W310X500	427	45.1	340	75.1	97
X454	415	41.3	336	68.7	91
X415	403	38.9	334	62.7	85
X375	391	35.4	330	57.2	79
X342	382	32.6	328	52.6	75
X313	374	30.0	325	48.3	71
X283	365	26.9	322	44.1	66
X253	356	24.4	319	39.6	62
X226	348	22.1	317	35.6	58
X202	341	20.1	315	31.8	54
X179	333	18.0	313	28.1	50
X158	327	15.5	310	25.1	47
X143	323	14.0	309	22.9	45
X129	318	13.1	308	20.6	43
X117	314	11.9	307	18.7	41
X107	311	10.9	306	17.0	39
X97	308	9.9	305	15.4	38
X86	310	9.1	254	16.3	36
X79	306	8.8	254	14.6	34
X74	310	9.4	205	16.3	36
X67	306	8.5	204	14.6	34
X60	303	7.5	203	13.1	33
X52	318	7.6	167	13.2	31
X44.5	313	6.6	166	11.2	28
X38.7	310	5.8	165	9.7	27
X32.7	313	6.6	102	10.8	24
X28.3	309	6.0	102	8.9	22
X23.8	305	5.6	101	6.7	20
X21	303	5.1	101	5.7	19
W250X167	289	19.2	265	31.8	49
X149	282	17.3	263	28.4	46
X131	275	15.4	261	25.1	42
X115	269	13.5	259	22.1	39
X101	264	11.9	257	19.6	37
X89	260	10.7	256	17.3	35
X80	256	9.4	255	15.6	33



**Table 4a (Continued)**

Dimensions for W-Shapes



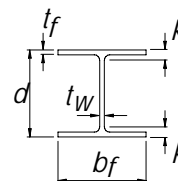
U.S. Customary Units					
Designation	Depth	Web	Flange		Distance
nominal depth (in) x nominal weight (lb/ft)	<i>d</i> (in)	thick- ness <i>t<sub>w</sub></i> (in)	width <i>b<sub>f</sub></i> (in)	thick- ness <i>t<sub>f</sub></i> (in)	<i>k</i> (in)
W10X49	10.0	0.34	10.0	0.56	1- 1/4
X45	10.1	0.35	8.0	0.62	1- 5/16
X39	9.92	0.32	8.0	0.53	1- 3/16
X33	9.73	0.29	8.0	0.44	1- 1/8
X30	10.5	0.30	5.8	0.51	1- 1/8
X26	10.3	0.26	5.8	0.44	1- 1/16
X22	10.2	0.24	5.8	0.36	15/16
X19	10.2	0.25	4.0	0.40	15/16
X17	10.1	0.24	4.0	0.33	7/8
X15	10.0	0.23	4.0	0.27	13/16
X12	9.87	0.19	4.0	0.21	3/4
W8X67	9.00	0.57	8.3	0.94	1- 5/8
X58	8.75	0.51	8.2	0.81	1- 1/2
X48	8.50	0.40	8.1	0.69	1- 3/8
X40	8.25	0.36	8.1	0.56	1- 1/4
X35	8.12	0.31	8.0	0.50	1- 3/16
X31	8.00	0.29	8.0	0.44	1- 1/8
X28	8.06	0.29	6.5	0.47	15/16
X24	7.93	0.25	6.5	0.40	7/8
X21	8.28	0.25	5.3	0.40	7/8
X18	8.14	0.23	5.3	0.33	13/16
X15	8.11	0.25	4.0	0.32	13/16
X13	7.99	0.23	4.0	0.26	3/4
X10	7.89	0.17	3.9	0.21	11/16
W6X25	6.38	0.32	6.1	0.46	15/16
X20	6.20	0.26	6.0	0.37	7/8
X15	5.99	0.23	6.0	0.26	3/4
X16	6.28	0.26	4.0	0.41	7/8
X12	6.03	0.23	4.0	0.28	3/4
X9	5.90	0.17	3.9	0.22	11/16
X8.5	5.83	0.17	3.9	0.19	11/16
W5X19	5.15	0.27	5.0	0.43	13/16
X16	5.01	0.24	5.0	0.36	3/4
W4X13	4.16	0.28	4.1	0.35	3/4

Metric Units					
Designation	Depth	Web	Flange		Distance
nominal depth (mm) x nominal weight (kg/m)	<i>d</i> (mm)	thick- ness <i>t<sub>w</sub></i> (mm)	width <i>b<sub>f</sub></i> (mm)	thick- ness <i>t<sub>f</sub></i> (mm)	<i>k</i> (mm)
W250X73	253	8.6	254	14.2	31
X67	257	8.9	204	15.7	33
X58	252	8.0	203	13.5	31
X49.1	247	7.4	202	11.0	28
X44.8	266	7.6	148	13.0	28
X38.5	262	6.6	147	11.2	26
X32.7	258	6.1	146	9.1	24
X28.4	260	6.4	102	10.0	23
X25.3	257	6.1	102	8.4	21
X22.3	254	5.8	102	6.9	20
X17.9	251	4.8	101	5.3	18
W200X100	229	14.5	210	23.7	41
X86	222	13.0	209	20.6	38
X71	216	10.2	206	17.4	35
X59	210	9.1	205	14.2	32
X52	206	7.9	204	12.6	30
X46.1	203	7.2	203	11.0	28
X41.7	205	7.2	166	11.8	25
X35.9	201	6.2	165	10.2	23
X31.3	210	6.4	134	10.2	22
X26.6	207	5.8	133	8.4	20
X22.5	206	6.2	102	8.0	20
X19.3	203	5.8	102	6.5	18
X15	200	4.3	100	5.2	17
W150X37.1	162	8.1	154	11.6	23
X29.8	157	6.6	153	9.3	21
X22.5	152	5.8	152	6.6	18
X24	160	6.6	102	10.3	22
X18	153	5.8	102	7.1	19
X13.5	150	4.3	100	5.5	17
X13	148	4.3	100	4.9	17
W130X28.1	131	6.9	128	10.9	20
X23.8	127	6.1	127	9.1	18
W100X19.3	106	7.1	103	8.8	19



**Table 4b**

Dimensions for HP-Shapes  
(Bearing Piles)

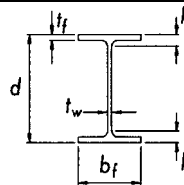


U.S. Customary Units						Metric Units					
Designation	Depth	Web	Flange		Distance	Designation	Depth	Web	Flange		Distance
nominal depth (in) x nominal weight (lb/ft)	<i>d</i> (in)	thick- ness <i>t<sub>w</sub></i> (in)	width <i>b<sub>f</sub></i> (in)	thick- ness <i>t<sub>f</sub></i> (in)	<i>k</i> (in)	nominal depth (mm) x nominal weight (kg/m)	<i>d</i> (mm)	thick- ness <i>t<sub>w</sub></i> (mm)	width <i>b<sub>f</sub></i> (mm)	thick- ness <i>t<sub>f</sub></i> (mm)	<i>k</i> (mm)
HP14X117	14.2	0.805	14.9	0.805	1- 1/2	HP360X174	361	20.4	378	20.4	38
X102	14.0	0.705	14.8	0.705	1- 3/8	X152	356	17.9	376	17.9	35
X89	13.8	0.615	14.7	0.615	1- 5/16	X132	351	15.6	373	15.6	33
X73	13.6	0.505	14.6	0.505	1- 3/16	X108	346	12.8	370	12.8	30
HP12X84	12.3	0.685	12.3	0.685	1- 3/8	HP310X125	312	17.4	312	17.4	35
X74	12.1	0.605	12.2	0.610	1- 5/16	X110	308	15.4	310	15.4	33
X63	11.9	0.515	12.1	0.515	1- 1/4	X93	303	13.1	308	13.1	30
X53	11.8	0.435	12.0	0.435	1- 1/8	X79	299	11.0	306	11.0	28
HP10X57	9.99	0.565	10.2	0.565	1- 1/4	HP250X85	254	14.4	260	14.4	32
X42	9.70	0.415	10.1	0.420	1- 1/8	X62	246	10.5	256	10.5	28
HP8X36	8.02	0.445	8.15	0.445	1- 1/8	HP200X53	204	11.3	207	11.3	29



**Table 4c**

Dimensions for M-Shapes

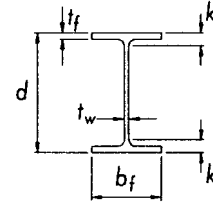


U.S. Customary Units						Metric Units					
Designation	Depth	Web	Flange		Distance	Designation	Depth	Web	Flange		Distance
nominal depth (in) x nominal weight (lb/ft)	<i>d</i> (in)	thick- ness <i>t<sub>w</sub></i> (in)	width <i>b<sub>f</sub></i> (in)	thick- ness <i>t<sub>f</sub></i> (in)	<i>k</i> (in)	nominal depth (mm) x nominal weight (kg/m)	<i>d</i> (mm)	thick- ness <i>t<sub>w</sub></i> (mm)	width <i>b<sub>f</sub></i> (mm)	thick- ness <i>t<sub>f</sub></i> (mm)	<i>k</i> (mm)
M12X11.8	12.0	0.177	3.07	0.225	9/16	M310X17.6	305	4.5	77.9	5.7	14
X10.8	12.0	0.160	3.07	0.210	9/16	X16.1	304	4.1	77.9	5.3	14
X10	12.0	0.149	3.25	0.180	1/2	X14.9	304	3.8	82.6	4.6	12
M10X9	10.0	0.157	2.69	0.206	9/16	M250X13.4	254	4.0	68.3	5.2	14
X8	9.95	0.141	2.69	0.182	9/16	X11.9	253	3.6	68.3	4.6	13
X7.5	9.99	0.130	2.69	0.173	7/16	X11.2	254	3.3	68.3	4.4	11
M8X6.5	8.00	0.135	2.28	0.189	9/16	M200X9.7	203	3.4	57.9	4.8	14
X6.2	8.00	0.129	2.28	0.177	7/16	X9.2	203	3.3	57.9	4.5	10
M6X4.4	6.00	0.114	1.84	0.171	3/8	M150X6.6	152	2.9	46.8	4.3	9
X3.7	5.92	0.098	2.00	0.129	5/16	X5.5	150	2.5	50.8	3.3	8
M5X18.9	5.00	0.316	5.00	0.416	13/16	M130X28.1	127	8.0	127.0	10.6	22
M4X6	3.80	0.130	3.80	0.160	1/2	M100X8.9	96.5	3.3	96.5	4.1	13



**Table 4d**

Dimensions for S-Shapes  
(American Standard Beams)



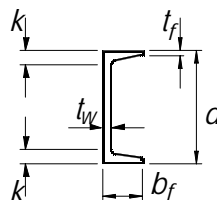
U.S. Customary Units						Metric Units					
Designation	Depth	Web	Flange		Distance	Designation	Depth	Web	Flange		Distance
nominal depth (in) x nominal weight (lb/ft)	$d$ (in)	thick- ness $t_w$ (in)	width $b_f$ (in)	thick- ness $t_f$ (in)	$k$ (in)	nominal depth (mm) x nominal weight (kg/m)	$d$ (mm)	thick- ness $t_w$ (mm)	width $b_f$ (mm)	thick- ness $t_f$ (mm)	$k$ (mm)
S24X121	24.5	0.800	8.05	1.090	2	S610X180	622	20.3	204	27.7	50
X106	24.5	0.620	7.87	1.090	2	X158	622	15.7	200	27.7	50
X100	24.0	0.745	7.25	0.870	1- 3/4	X149	610	18.9	184	22.1	44
X90	24.0	0.625	7.13	0.870	1- 3/4	X134	610	15.9	181	22.1	44
X80	24.0	0.500	7.00	0.870	1- 3/4	X119	610	12.7	178	22.1	44
S20X96	20.3	0.800	7.20	0.920	1- 3/4	S510X143	516	20.3	183	23.4	45
X86	20.3	0.660	7.06	0.920	1- 3/4	X128	516	16.8	179	23.4	45
X75	20.0	0.635	6.39	0.795	1- 5/8	X112	508	16.1	162	20.2	41
X66	20.0	0.505	6.26	0.795	1- 5/8	X98.2	508	12.8	159	20.2	41
S18X70	18.0	0.711	6.25	0.691	1- 1/2	S460X104	457	18.1	159	17.6	37
X54.7	18.0	0.461	6.00	0.691	1- 1/2	X81.4	457	11.7	152	17.6	37
S15X50	15.0	0.550	5.64	0.622	1- 3/8	S380X74	381	14.0	143	15.8	34
X42.9	15.0	0.411	5.50	0.622	1- 3/8	X64	381	10.4	140	15.8	34
S12X50	12.0	0.687	5.48	0.659	1- 7/16	S310X74	305	17.4	139	16.7	35
X40.8	12.0	0.462	5.25	0.659	1- 7/16	X60.7	305	11.7	133	16.7	35
X35	12.0	0.428	5.08	0.544	1- 3/16	X52	305	10.9	129	13.8	30
X31.8	12.0	0.350	5.00	0.544	1- 3/16	X47.3	305	8.9	127	13.8	30
S10X35	10.0	0.594	4.94	0.491	1- 1/8	S250X52	254	15.1	126	12.5	27
X25.4	10.0	0.311	4.66	0.491	1- 1/8	X37.8	254	7.9	118	12.5	27
S8X23	8.0	0.441	4.17	0.425	1	S200X34	203	11.2	106	10.8	24
X18.4	8.0	0.271	4.00	0.425	1	X27.4	203	6.9	102	10.8	24
S6X17.25	6.0	0.465	3.57	0.359	13/16	S150X25.7	152	11.8	90.6	9.1	20
X12.5	6.0	0.232	3.33	0.359	13/16	X18.6	152	5.9	84.6	9.1	20
S5X10	5.0	0.214	3.00	0.326	3/4	S130X15	127	5.4	76.3	8.3	19
S4X9.5	4.0	0.326	2.80	0.293	3/4	S100X14.1	102	8.3	71	7.4	18
X7.7	4.0	0.193	2.66	0.293	3/4	X11.5	102	4.9	67.6	7.4	18
S3X7.5	3.0	0.349	2.51	0.260	5/8	S75X11.2	76.2	8.9	63.7	6.6	16
X5.7	3.0	0.170	2.33	0.260	5/8	X8.5	76.2	4.3	59.2	6.6	16





**Table 4e**

Dimensions for C-Shapes  
(American Standard Channels)



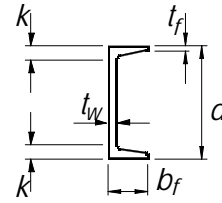
U.S. Customary Units					
Designation	Depth	Web	Flange		Distance
nominal depth (in) x nominal weight (lb/ft)	<i>d</i> (in)	thick- ness <i>t<sub>w</sub></i> (in)	width <i>b<sub>f</sub></i> (in)	thick- ness <i>t<sub>f</sub></i> (in)	<i>k</i> (in)
C15X50	15	0.716	3.72	0.650	1- 7/16
X40	15	0.520	3.52	0.650	1- 7/16
X33.9	15	0.400	3.40	0.650	1- 7/16
C12X30	12	0.510	3.17	0.501	1- 1/8
X25	12	0.387	3.05	0.501	1- 1/8
X20.7	12	0.282	2.94	0.501	1- 1/8
C10X30	10	0.673	3.03	0.436	1
X25	10	0.526	2.89	0.436	1
X20	10	0.379	2.74	0.436	1
X15.3	10	0.240	2.60	0.436	1
C9X20	9	0.448	2.65	0.413	1
X15	9	0.285	2.49	0.413	1
X13.4	9	0.233	2.43	0.413	1
C8X18.75	8	0.487	2.53	0.390	15/16
X13.75	8	0.303	2.34	0.390	15/16
X11.5	8	0.220	2.26	0.390	15/16
C7X14.75	7	0.419	2.30	0.366	7/8
X12.25	7	0.314	2.19	0.366	7/8
X9.8	7	0.210	2.09	0.366	7/8
C6X13	6	0.437	2.16	0.343	13/16
X10.5	6	0.314	2.03	0.343	13/16
X8.2	6	0.200	1.92	0.343	13/16
C5X9	5	0.325	1.89	0.320	3/4
X6.7	5	0.190	1.75	0.320	3/4
C4X7.25	4	0.321	1.72	0.296	3/4
X5.4	4	0.184	1.58	0.296	3/4
X4.5	4	0.125	1.58	0.296	3/4
C3X6	3	0.356	1.60	0.273	11/16
X5	3	0.258	1.50	0.273	11/16
X4.1	3	0.170	1.41	0.273	11/16
X3.5	3	0.132	1.37	0.273	11/16

Metric Units					
Designation	Depth	Web	Flange		Distance
nominal depth (mm) x nominal weight (kg/m)	<i>d</i> (mm)	thick- ness <i>t<sub>w</sub></i> (mm)	width <i>b<sub>f</sub></i> (mm)	thick- ness <i>t<sub>f</sub></i> (mm)	<i>k</i> (mm)
C380X74	381	18.2	94.4	16.5	36
X60	381	13.2	89.4	16.5	36
X50.4	381	10.2	86.4	16.5	36
C310X45	305	13.0	80.5	12.7	28
X37	305	9.8	77.4	12.7	28
X30.8	305	7.2	74.7	12.7	28
C250X45	254	17.1	77.0	11.1	25
X37	254	13.4	73.3	11.1	25
X30	254	9.6	69.6	11.1	25
X22.8	254	6.1	66.0	11.1	25
C230X30	229	11.4	67.3	10.5	24
X22	229	7.2	63.1	10.5	24
X19.9	229	5.9	61.8	10.5	24
C200X27.9	203	12.4	64.2	9.9	23
X20.5	203	7.7	59.5	9.9	23
X17.1	203	5.6	57.4	9.9	23
C180X22	178	10.6	58.4	9.3	22
X18.2	178	8.0	55.7	9.3	22
X14.6	178	5.3	53.1	9.3	22
C150X19.3	152	11.1	54.8	8.7	20
X15.6	152	8.0	51.7	8.7	20
X12.2	152	5.1	48.8	8.7	20
C130X13	127	8.3	47.9	8.1	19
X10.4	127	4.8	44.5	8.1	19
C100X10.8	102	8.2	43.7	7.5	18
X8	102	4.7	40.2	7.5	18
X6.7	102	3.2	40.2	7.5	18
C75X8.9	76.2	9.0	40.5	6.9	17
X7.4	76.2	6.6	38.0	6.9	17
X6.1	76.2	4.3	35.8	6.9	17
X5.2	76.2	3.4	34.8	6.9	17



**Table 4f**

Dimensions for MC-Shapes  
(Miscellaneous Channels)

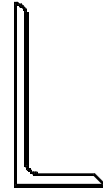


U.S. Customary Units					
Designation	Depth	Web	Flange		Distance
nominal depth (in) x nominal weight (lb/ft)	<i>d</i> (in)	thick- ness <i>t<sub>w</sub></i> (in)	width <i>b<sub>f</sub></i> (in)	thick- ness <i>t<sub>f</sub></i> (in)	<i>k</i> (in)
MC18X58	18	0.700	4.20	0.625	1- 7/16
MC18X51.9	18	0.600	4.10	0.625	1- 7/16
MC18X45.8	18	0.500	4.00	0.625	1- 7/16
MC18X42.7	18	0.450	3.95	0.625	1- 7/16
MC13X50	13	0.787	4.41	0.610	1- 7/16
MC13X40	13	0.560	4.18	0.610	1- 7/16
MC13X35	13	0.447	4.07	0.610	1- 7/16
MC13X31.8	13	0.375	4.00	0.610	1- 7/16
MC12X50	12	0.835	4.14	0.700	1- 5/16
MC12X45	12	0.712	4.01	0.700	1- 5/16
MC12X40	12	0.590	3.89	0.700	1- 5/16
MC12X35	12	0.467	3.77	0.700	1- 5/16
MC12X31	12	0.370	3.67	0.700	1- 5/16
MC12X10.6	12	0.190	1.50	0.309	3/4
MC10X41.1	10	0.796	4.32	0.575	1- 5/16
MC10X33.6	10	0.575	4.10	0.575	1- 5/16
MC10X28.5	10	0.425	3.95	0.575	1- 5/16
MC10X25	10	0.380	3.41	0.575	1- 5/16
MC10X22	10	0.290	3.32	0.575	1- 5/16
MC10X8.4	10	0.170	1.50	0.280	3/4
MC9X25.4	9	0.450	3.50	0.550	1- 1/4
MC9X23.9	9	0.400	3.45	0.550	1- 1/4
MC8X22.8	8	0.427	3.50	0.525	1- 3/16
MC8X21.4	8	0.375	3.45	0.525	1- 3/16
MC8X20	8	0.400	3.03	0.500	1- 1/8
MC8X18.7	8	0.353	2.98	0.500	1- 1/8
MC8X8.5	8	0.179	1.87	0.311	13/16
MC7X22.7	7	0.503	3.60	0.500	1- 1/8
MC7X19.1	7	0.352	3.45	0.500	1- 1/8
MC6X18	6	0.379	3.50	0.475	1- 1/16
MC6X15.3	6	0.340	3.50	0.385	7/8
MC6X16.3	6	0.375	3.00	0.475	1- 1/16
MC6X15.1	6	0.316	2.94	0.475	1- 1/16
MC6X12	6	0.310	2.50	0.375	7/8

Metric Units					
Designation	Depth	Web	Flange		Distance
nominal depth (mm) x nominal weight (kg/m)	<i>d</i> (mm)	thick- ness <i>t<sub>w</sub></i> (mm)	width <i>b<sub>f</sub></i> (mm)	thick- ness <i>t<sub>f</sub></i> (mm)	<i>k</i> (mm)
MC460X86	457	17.8	107.0	15.9	36
MC460X77.2	457	15.2	104.0	15.9	36
MC460X68.2	457	12.7	102.0	15.9	36
MC460X63.5	457	11.4	100.0	15.9	36
MC330X74	330	20.0	112.0	15.5	36
MC330X60	330	14.2	106.0	15.5	36
MC330X52	330	11.4	103.0	15.5	36
MC330X47.3	330	9.5	102.0	15.5	36
MC310X74	305	21.2	105.0	17.8	34
MC310X67	305	18.1	102.0	17.8	34
MC310X60	305	15.0	98.8	17.8	34
MC310X52	305	11.9	95.7	17.8	34
MC310X46	305	9.4	93.2	17.8	34
MC310X15.8	305	4.8	38.1	7.8	19
MC250X61.2	254	20.2	110.0	14.6	33
MC250X50	254	14.6	104.0	14.6	33
MC250X42.4	254	10.8	100.0	14.6	33
MC250X37	254	9.7	86.5	14.6	33
MC250X33	254	7.4	84.2	14.6	33
MC250X12.5	254	4.3	38.1	7.1	18
MC230X37.8	229	11.4	88.9	14.0	31
MC230X35.6	229	10.2	87.6	14.0	31
MC200X33.9	203	10.8	89.0	13.3	30
MC200X31.8	203	9.5	87.6	13.3	30
MC200X29.8	203	10.2	76.8	12.7	28
MC200X27.8	203	9.0	75.6	12.7	28
MC200X12.6	203	4.5	47.6	7.9	19
MC180X33.8	178	12.8	91.5	12.7	28
MC180X28.4	178	8.9	87.7	12.7	28
MC150X26.8	152	9.6	89.0	12.1	27
MC150X22.8	152	8.6	88.9	9.8	22
MC150X24.3	152	9.5	76.2	12.1	27
MC150X22.5	152	8.0	74.7	12.1	27
MC150X17.9	152	7.9	63.4	9.5	21

**Table 4g**


Dimensions for L-Shapes  
(Equal and Unequal Leg Angles)



U.S. Customary Units		Metric Units	
Designation	Nominal Weight	Designation	Nominal Weight
leg size (in) x leg size (in) x thickness (in)	W (lb/ft)	leg size (mm) x leg size (mm) x thickness (mm)	W (kg/m)
L8X8X1-1/8	57.2	L203X203X28.6	84.7
X1	51.3	X25.4	75.9
X7/8	45.3	X22.2	67.0
X3/4	39.2	X19	57.9
X5/8	33.0	X15.9	48.7
X9/16	29.8	X14.3	44.0
X1/2	26.7	X12.7	39.3
L8X6X1	44.4	L203X152X25.4	65.5
X7/8	39.3	X22.2	57.9
X3/4	34.0	X19	50.1
X5/8	28.6	X15.9	42.2
X9/16	25.9	X14.3	38.1
X1/2	23.2	X12.7	34.1
X7/16	20.4	X11.1	29.9
L8X4X1	37.6	L203X102X25.4	55.4
X7/8	33.3	X22.2	49.3
X3/4	28.9	X19	42.5
X5/8	24.4	X15.9	36.0
X9/16	22.1	X14.3	32.4
X1/2	19.7	X12.7	29.0
X7/16	17.4	X11.1	25.6
L7X4X3/4	26.2	L178X102X19	38.8
X5/8	22.1	X15.9	32.7
X1/2	17.9	X12.7	26.5
X7/16	15.8	X11.1	23.4
X3/8	13.6	X9.5	20.2
L6X6X1	37.5	L152X152X25.4	55.7
X7/8	33.2	X22.2	49.3
X3/4	28.8	X19	42.7
X5/8	24.3	X15.9	36.0
X9/16	22.0	X14.3	32.6
X1/2	19.6	X12.7	29.2
X7/16	17.3	X11.1	25.6

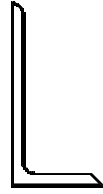


**Table 4g (Continued)**  
 Dimensions for L-Shapes  
 (Equal and Unequal Leg Angles)



<b>U.S. Customary Units</b>		<b>Metric Units</b>	
Designation	Nominal Weight	Designation	Nominal Weight
leg size (in) x leg size (in) x thickness (in)	W (lb/ft)	leg size (mm) x leg size (mm) x thickness (mm)	W (kg/m)
L6X6X3/8	14.9	L152X152X9.5	22.2
X5/16	12.5	X7.9	18.5
L6X4X7/8	27.2	L152X102X22.2	40.3
X3/4	23.6	X19	35.0
X5/8	19.9	X15.9	29.6
X9/16	18.1	X14.3	26.8
X1/2	16.2	X12.7	24.0
X7/16	14.2	X11.1	21.2
X3/8	12.3	X9.5	18.2
X5/16	10.3	X7.9	15.3
L6X3-1/2X1/2	15.4	L152X89X12.7	22.7
X3/8	11.7	X9.5	17.3
X5/16	9.83	X7.9	14.5
L5X5X7/8	27.3	L127X127X22.2	40.5
X3/4	23.7	X19	35.1
X5/8	20.1	X15.9	29.8
X1/2	16.3	X12.7	24.1
X7/16	14.4	X11.1	21.3
X3/8	12.4	X9.5	18.3
X5/16	10.4	X7.9	15.3
L5X3-1/2X3/4	19.8	L127X89X19	29.3
X5/8	16.8	X15.9	24.9
X1/2	13.6	X12.7	20.2
X3/8	10.4	X9.5	15.4
X5/16	8.72	X7.9	12.9
X1/4	7.03	X6.4	10.4
L5X3X1/2	12.8	L127X76X12.7	19.0
X7/16	11.3	X11.1	16.7
X3/8	9.74	X9.5	14.5
X5/16	8.19	X7.9	12.1
X1/4	6.60	X6.4	9.8

**Table 4g (Continued)**  
Dimensions for L-Shapes  
(Equal and Unequal Leg Angles)

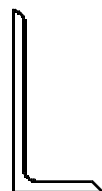


<b>U.S. Customary Units</b>		<b>Metric Units</b>	
Designation	Nominal Weight	Designation	Nominal Weight
leg size (in) x leg size (in) x thickness (in)	W (lb/ft)	leg size (mm) x leg size (mm) x thickness (mm)	W (kg/m)
L4X4X3/4	18.5	L102X102X19	27.5
X5/8	15.7	X15.9	23.4
X1/2	12.7	X12.7	19.0
X7/16	11.2	X11.1	16.8
X3/8	9.72	X9.5	14.6
X5/16	8.16	X7.9	12.2
X1/4	6.58	X6.4	9.8
L4X3-1/2X1/2	11.9	L102X89X12.7	17.6
X3/8	9.10	X9.5	13.5
X5/16	7.65	X7.9	11.4
X1/4	6.18	X6.4	9.2
L4X3X5/8	13.6	L102X76X15.9	20.2
X1/2	11.1	X12.7	16.4
X3/8	8.47	X9.5	12.6
X5/16	7.12	X7.9	10.7
X1/4	5.75	X6.4	8.6
L3-1/2X3-1/2X1/2	11.1	L89X89X12.7	16.5
X7/16	9.82	X11.1	14.6
X3/8	8.51	X9.5	12.6
X5/16	7.16	X7.9	10.7
X1/4	5.79	X6.4	8.6
L3-1/2X3X1/2	10.3	L89X76X12.7	15.1
X7/16	9.09	X11.1	13.5
X3/8	7.88	X9.5	11.7
X5/16	6.65	X7.9	9.8
X1/4	5.38	X6.4	8.0
L3-1/2X2-1/2X1/2	9.41	L89X64X12.7	13.9
X3/8	7.23	X9.5	10.7
X5/16	6.10	X7.9	9.0
X1/4	4.94	X6.4	7.3
L3X3X1/2	9.35	L76X76X12.7	14.0
X7/16	8.28	X11.1	12.4



**Table 4g (Continued)**

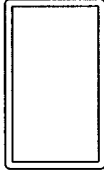
Dimensions for L-Shapes  
(Equal and Unequal Leg Angles)



U.S. Customary Units		Metric Units	
Designation	Nominal Weight	Designation	Nominal Weight
leg size (in) x leg size (in) x thickness (in)	W (lb/ft)	leg size (mm) x leg size (mm) x thickness (mm)	W (kg/m)
L3X3X3/8	7.17	L76X76X9.5	10.7
X5/16	6.04	X7.9	9.1
X1/4	4.89	X6.4	7.3
X3/16	3.70	X4.8	5.5
L3X2-1/2X1/2	8.53	L76X64X12.7	12.6
X7/16	7.56	X11.1	11.3
X3/8	6.56	X9.5	9.8
X5/16	5.54	X7.9	8.3
X1/4	4.49	X6.4	6.7
X3/16	3.41	X4.8	5.1
L3X2X1/2	7.70	L76X51X12.7	11.5
X3/8	5.95	X9.5	8.8
X5/16	5.03	X7.9	7.4
X1/4	4.09	X6.4	6.1
X3/16	3.12	X4.8	4.6
L2-1/2X2-1/2X1/2	7.65	L64X64X12.7	11.4
X3/8	5.90	X9.5	8.7
X5/16	4.98	X7.9	7.4
X1/4	4.04	X6.4	6.1
X3/16	3.06	X4.8	4.6
L2-1/2X2X3/8	5.30	L64X51X9.5	7.9
X5/16	4.49	X7.9	6.7
X1/4	3.65	X6.4	5.4
X3/16	2.78	X4.8	4.2
L2X2X3/8	4.65	L51X51X9.5	7.0
X5/16	3.94	X7.9	5.8
X1/4	3.21	X6.4	4.7
X3/16	2.46	X4.8	3.6
X1/8	1.67	X3.2	2.4



**Table 4h**  
Dimensions for Rectangular  
and Square HSS

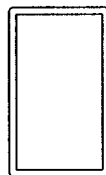


<b>U.S. Customary Units</b>		<b>Metric Units</b>	
Nominal Outside Dimensions (in) x Nominal Thickness (in)	Nominal Weight (lb/ft)	Nominal Outside Dimensions (mm) x Nominal Thickness (mm)	Nominal Weight (kg/m)
HSS20X12X5/8	127	HSS508X304.8X15.9	189.6
X1/2	103	X12.7	153.9
X3/8	78.4	X9.5	116.2
X5/16	65.8	X7.9	98.0
HSS20X8X5/8	110	HSS508X203.2X15.9	164.1
X1/2	89.6	X12.7	133.5
X3/8	68.2	X9.5	101.5
X5/16	57.3	X7.9	85.2
HSS20X4X1/2	75.9	HSS508X101.6X12.7	113.1
X3/8	58	X9.5	86.3
X5/16	48.8	X7.9	72.6
HSS18X12X5/8	119	HSS457.2X304.8X15.9	176.4
X1/2	96.4	X12.7	143.7
X3/8	73.3	X9.5	109.1
HSS18X6X5/8	93.1	HSS457.2X152.4X15.9	138.6
X1/2	75.9	X12.7	113.1
X3/8	58	X9.5	86.3
X5/16	48.8	X7.9	72.6
X1/4	39.4	X6.4	58.6
HSS16X16X5/8	127	HSS406.4X406.4X15.9	189.6
X1/2	103	X12.7	153.9
X3/8	78.4	X9.5	116.2
X5/16	65.8	X7.9	98.0
HSS16X12X5/8	110	HSS406.4X304.8X15.9	164.1
X1/2	89.6	X12.7	133.5
X3/8	68.2	X9.5	101.5
X5/16	57.3	X7.9	85.2
HSS16X8X5/8	93.1	HSS406.4X203.2X15.9	138.6
X1/2	75.9	X12.7	113.1
X3/8	58	X9.5	86.3
X5/16	48.8	X7.9	72.6
HSS16X4X1/2	62.3	HSS406.4X101.6X12.7	92.8
X3/8	47.8	X9.5	71.2
X5/16	40.3	X7.9	59.9



**Table 4h (Continued)**

Dimensions for Rectangular  
and Square HSS



<b>U.S. Customary Units</b>		<b>Metric Units</b>	
Nominal Outside Dimensions (in) x Nominal Thickness (in)	Nominal Weight (lb/ft)	Nominal Outside Dimensions (mm) x Nominal Thickness (mm)	Nominal Weight (kg/m)
HSS14X14X5/8	110	HSS355.6X355.6X15.9	164.1
X1/2	89.6	X12.7	133.5
X3/8	68.2	X9.5	101.5
X5/16	57.3	X7.9	85.2
HSS14X12X1/2	82.7	HSS355.6X304.8X12.7	123.3
X3/8	63.1	X9.5	93.9
HSS14X10X5/8	93.1	HSS355.6X254X15.9	138.6
X1/2	75.9	X12.7	113.1
X3/8	58	X9.5	86.3
X5/16	48.8	X7.9	72.6
X1/4	39.4	X6.4	58.6
HSS14X6X5/8	76.1	HSS355.6X152.4X15.9	113.1
X1/2	62.3	X12.7	92.8
X3/8	47.8	X9.5	71.2
X5/16	40.3	X7.9	59.9
X1/4	32.6	X6.4	48.5
X3/16	24.7	X4.8	36.8
HSS14X4X5/8	67.6	HSS355.6X101.6X15.9	100.6
X1/2	55.5	X12.7	82.6
X3/8	42.7	X9.5	63.5
X5/16	36	X7.9	53.6
X1/4	29.2	X6.4	43.4
X3/16	22.2	X4.8	32.9
HSS12X12X5/8	93.1	HSS304.8X304.8X15.9	138.6
X1/2	75.9	X12.7	113.1
X3/8	58	X9.5	86.3
X5/16	48.8	X7.9	72.6
X1/4	39.4	X6.4	58.6
HSS12X10X1/2	69.1	HSS304.8X254X12.7	103.0
X3/8	52.9	X9.5	78.7
X5/16	44.6	X7.9	66.3
X1/4	36	X6.4	53.5
HSS12X8X5/8	76.1	HSS304.8X203.2X15.9	113.1
X1/2	62.3	X12.7	92.8
X3/8	47.8	X9.5	71.2
X5/16	40.3	X7.9	59.9
X1/4	32.6	X6.4	48.5
X3/16	24.7	X4.8	36.8
HSS12X6X5/8	67.6	HSS304.8X152.4X15.9	100.6
X1/2	55.5	X12.7	82.6
X3/8	42.7	X9.5	63.5
X5/16	36	X7.9	53.6
X1/4	29.2	X6.4	43.4
X3/16	22.2	X4.8	32.9



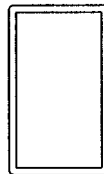
**Table 4h (Continued)**Dimensions for Rectangular  
and Square HSS

<b>U.S. Customary Units</b>		<b>Metric Units</b>	
Nominal Outside Dimensions (in) x Nominal Thickness (in)	Nominal Weight (lb/ft)	Nominal Outside Dimensions (mm) x Nominal Thickness (mm)	Nominal Weight (kg/m)
HSS12X4X5/8	59.1	HSS304.8X101.6X15.9	88.0
X1/2	48.7	X12.7	72.5
X3/8	37.6	X9.5	56.0
X5/16	31.8	X7.9	47.3
X1/4	25.8	X6.4	38.3
X3/16	19.6	X4.8	29.2
HSS12X3-1/2X3/8	36.3	HSS304.8X88.9X9.5	54.0
X5/16	30.7	X7.9	45.7
HSS12X3X5/16	29.7	HSS304.8X76.2X7.9	44.1
X1/4	24.1	X6.4	35.9
X3/16	18.3	X4.8	27.3
HSS12X2X1/4	22.4	HSS304.8X50.8X6.4	33.3
X3/16	17.1	X4.8	25.4
HSS10X10X5/8	76.1	HSS254X254X15.9	113.1
X1/2	62.3	X12.7	92.8
X3/8	47.8	X9.5	71.2
X5/16	40.3	X7.9	59.9
X1/4	32.6	X6.4	48.5
X3/16	24.7	X4.8	36.8
HSS10X8X1/2	55.5	HSS254X203.2X12.7	82.6
X3/8	42.7	X9.5	63.5
X5/16	36	X7.9	53.6
X1/4	29.2	X6.4	43.4
X3/16	22.2	X4.8	32.9
HSS10X6X5/8	59.1	HSS254X152.4X15.9	88.0
X1/2	48.7	X12.7	72.5
X3/8	37.6	X9.5	56.0
X5/16	31.8	X7.9	47.3
X1/4	25.8	X6.4	38.3
X3/16	19.6	X4.8	29.2



**Table 4h (Continued)**

Dimensions for Rectangular  
and Square HSS



<b>U.S. Customary Units</b>		<b>Metric Units</b>	
Nominal Outside Dimensions (in) x Nominal Thickness (in)	Nominal Weight (lb/ft)	Nominal Outside Dimensions (mm) x Nominal Thickness (mm)	Nominal Weight (kg/m)
HSS10X5X3/8	35.1	HSS254X127X9.5	52.2
X5/16	29.7	X7.9	44.1
X1/4	24.1	X6.4	35.9
X3/16	18.3	X4.8	27.3
HSS10X4X5/8	50.6	HSS254X101.6X15.9	75.2
X1/2	41.9	X12.7	62.4
X3/8	32.5	X9.5	48.3
X5/16	27.5	X7.9	41.0
X1/4	22.4	X6.4	33.3
X3/16	17.1	X4.8	25.4
HSS10X3-1/2X3/16	16.4	HSS254X88.9X4.8	24.5
HSS10X3X3/8	30	HSS254X76.2X9.5	44.5
X5/16	25.4	X7.9	37.8
X1/4	20.7	X6.4	30.8
X3/16	15.8	X4.8	23.4
X1/8	10.7	X3.2	15.9
HSS10X2X3/8	27.4	HSS254X50.8X9.5	40.8
X5/16	23.3	X7.9	34.7
X1/4	19	X6.4	28.2
X3/16	14.5	X4.8	21.6
HSS9X7X5/8	59.1	HSS228.6X177.8X15.9	88.0
X1/2	48.7	X12.7	72.5
X3/8	37.6	X9.5	56.0
X5/16	31.8	X7.9	47.3
X1/4	25.8	X6.4	38.3
X3/16	19.6	X4.8	29.2
HSS9X5X5/8	50.6	HSS228.6X127X15.9	75.2
X1/2	41.9	X12.7	62.4
X3/8	32.5	X9.5	48.3
X5/16	27.5	X7.9	41.0
X1/4	22.4	X6.4	33.3
X3/16	17.1	X4.8	25.4
HSS9X3X1/2	35.1	HSS228.6X76.2X12.7	52.2
X3/8	27.4	X9.5	40.8
X5/16	23.3	X7.9	34.7
X1/4	19	X6.4	28.2
X3/16	14.5	X4.8	21.6



**Table 4h (Continued)**

Dimensions for Rectangular  
and Square HSS

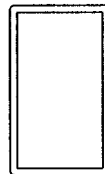


<b>U.S. Customary Units</b>		<b>Metric Units</b>	
Nominal Outside Dimensions (in) x Nominal Thickness (in)	Nominal Weight (lb/ft)	Nominal Outside Dimensions (mm) x Nominal Thickness (mm)	Nominal Weight (kg/m)
HSS8X8X5/8	59.1	HSS203.2X203.2X15.9	88.0
X1/2	48.7	X12.7	72.5
X3/8	37.6	X9.5	56.0
X5/16	31.8	X7.9	47.3
X1/4	25.8	X6.4	38.3
X3/16	19.6	X4.8	29.2
HSS8X6X5/8	50.6	HSS203.2X152.4X15.9	75.2
X1/2	41.9	X12.7	62.4
X3/8	32.5	X9.5	48.3
X5/16	27.5	X7.9	41.0
X1/4	22.4	X6.4	33.3
X3/16	17.1	X4.8	25.4
HSS8X4X5/8	42.1	HSS203.2X101.6X15.9	62.6
X1/2	35.1	X12.7	52.2
X3/8	27.4	X9.5	40.8
X5/16	23.3	X7.9	34.7
X1/4	19	X6.4	28.2
X3/16	14.5	X4.8	21.6
X1/8	9.85	X3.2	14.7
HSS8X3X1/2	31.7	HSS203.2X76.2X12.7	47.2
X3/8	24.9	X9.5	37.0
X5/16	21.2	X7.9	31.5
X1/4	17.3	X6.4	25.7
X3/16	13.2	X4.8	19.7
X1/8	9	X3.2	13.4
HSS8X2X3/8	22.3	HSS203.2X50.8X9.5	33.1
X5/16	19	X7.9	28.3
X1/4	15.6	X6.4	23.1
X3/16	12	X4.8	17.7
X1/8	8.15	X3.2	12.1
HSS7X7X5/8	50.6	HSS177.8X177.8X15.9	75.2
X1/2	41.9	X12.7	62.4
X3/8	32.5	X9.5	48.3
X5/16	27.5	X7.9	41.0
X1/4	22.4	X6.4	33.3
X3/16	17.1	X4.8	25.4



**Table 4h (Continued)**

Dimensions for Rectangular  
and Square HSS



<b>U.S. Customary Units</b>		<b>Metric Units</b>	
Nominal Outside Dimensions (in) x Nominal Thickness (in)	Nominal Weight (lb/ft)	Nominal Outside Dimensions (mm) x Nominal Thickness (mm)	Nominal Weight (kg/m)
HSS7X5X5/8	42.1	HSS177.8X127X15.9	62.6
X1/2	35.1	X12.7	52.2
X3/8	27.4	X9.5	40.8
X5/16	23.3	X7.9	34.7
X1/4	19	X6.4	28.2
X3/16	14.5	X4.8	21.6
X1/8	9.85	X3.2	14.7
HSS7X4X1/2	31.7	HSS177.8X101.6X12.7	47.2
X3/8	24.9	X9.5	37.0
X5/16	21.2	X7.9	31.5
X1/4	17.3	X6.4	25.7
X3/16	13.2	X4.8	19.7
X1/8	9	X3.2	13.4
HSS7X3X1/2	28.3	HSS177.8X76.2X12.7	42.1
X3/8	22.3	X9.5	33.1
X5/16	19	X7.9	28.3
X1/4	15.6	X6.4	23.1
X3/16	12	X4.8	17.7
X1/8	8.15	X3.2	12.1
HSS6X6X5/8	42.1	HSS152.4X152.4X15.9	62.6
X1/2	35.1	X12.7	52.2
X3/8	27.4	X9.5	40.8
X5/16	23.3	X7.9	34.7
X1/4	19	X6.4	28.2
X3/16	14.5	X4.8	21.6
X1/8	9.85	X3.2	14.7
HSS6X5X3/8	24.9	HSS152.4X127X9.5	37.0
X5/16	21.2	X7.9	31.5
X1/4	17.3	X6.4	25.7
X3/16	13.2	X4.8	19.7
HSS6X4X1/2	28.3	HSS152.4X101.6X12.7	42.1
X3/8	22.3	X9.5	33.1
X5/16	19	X7.9	28.3
X1/4	15.6	X6.4	23.1
X3/16	12	X4.8	17.7
X1/8	8.15	X3.2	12.1

**Table 4h (Continued)**Dimensions for Rectangular  
and Square HSS

<b>U.S. Customary Units</b>		<b>Metric Units</b>	
Nominal Outside Dimensions (in) x Nominal Thickness (in)	Nominal Weight (lb/ft)	Nominal Outside Dimensions (mm) x Nominal Thickness (mm)	Nominal Weight (kg/m)
HSS6X3X1/2	24.9	HSS152.4X76.2X12.7	37.0
X3/8	19.7	X9.5	29.4
X5/16	16.9	X7.9	25.2
X1/4	13.9	X6.4	20.7
X3/16	10.7	X4.8	15.9
X1/8	7.3	X3.2	10.9
HSS6X2X3/8	17.2	HSS152.4X50.8X9.5	25.6
X5/16	14.8	X7.9	22.0
X1/4	12.2	X6.4	18.1
X3/16	9.4	X4.8	14.0
X1/8	6.45	X3.2	9.59
HSS5-1/2X5-1/2X3/8	24.9	HSS139.7X139.7X9.5	37.0
X5/16	21.2	X7.9	31.5
X1/4	17.3	X6.4	25.7
X3/16	13.2	X4.8	19.7
X1/8	9	X3.2	13.4
HSS5X5X1/2	28.3	HSS127X127X12.7	42.1
X3/8	22.3	X9.5	33.1
X5/16	19	X7.9	28.3
X1/4	15.6	X6.4	23.1
X3/16	12	X4.8	17.7
X1/8	8.15	X3.2	12.1
HSS5X4X1/2	24.9	HSS127X101.6X12.7	37.0
X3/8	19.7	X9.5	29.4
X5/16	16.9	X7.9	25.2
X1/4	13.9	X6.4	20.7
X3/16	10.7	X4.8	15.9
HSS5X3X1/2	21.5	HSS127X76.2X12.7	32.0
X3/8	17.2	X9.5	25.6
X5/16	14.8	X7.9	22.0
X1/4	12.2	X6.4	18.1
X3/16	9.4	X4.8	14.0
X1/8	6.45	X3.2	9.59
HSS5X2-1/2X1/4	11.3	HSS127X63.5X6.4	16.8
X3/16	8.77	X4.8	13.0
X1/8	6.02	X3.2	8.96



**Table 4h (Continued)**

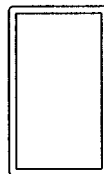
Dimensions for Rectangular  
and Square HSS



<b>U.S. Customary Units</b>		<b>Metric Units</b>	
Nominal Outside Dimensions (in) x Nominal Thickness (in)	Nominal Weight (lb/ft)	Nominal Outside Dimensions (mm) x Nominal Thickness (mm)	Nominal Weight (kg/m)
HSS5X2X3/8	14.6	HSS127X50.8X9.5	21.8
X5/16	12.7	X7.9	18.9
X1/4	10.5	X6.4	15.6
X3/16	8.13	X4.8	12.1
X1/8	5.6	X3.2	8.33
HSS4-1/2X4-1/2X1/2	24.9	HSS114.3X114.3X12.7	37.0
X3/8	19.7	X9.5	29.4
X5/16	16.9	X7.9	25.2
X1/4	13.9	X6.4	20.7
X3/16	10.7	X4.8	15.9
X1/8	7.3	X3.2	10.9
HSS4X4X1/2	21.5	HSS101.6X101.6X12.7	32.0
X3/8	17.2	X9.5	25.6
X5/16	14.8	X7.9	22.0
X1/4	12.2	X6.4	18.1
X3/16	9.4	X4.8	14.0
X1/8	6.45	X3.2	9.59
HSS4X3X3/8	14.6	HSS101.6X76.2X9.5	21.8
X5/16	12.7	X7.9	18.9
X1/4	10.5	X6.4	15.6
X3/16	8.13	X4.8	12.1
X1/8	5.6	X3.2	8.33
HSS4X2-1/2X5/16	11.6	HSS101.6X63.5X7.9	17.2
X1/4	9.63	X6.4	14.4
X3/16	7.49	X4.8	11.1
HSS4X2X3/8	12.1	HSS101.6X50.8X9.5	17.9
X5/16	10.5	X7.9	15.7
X1/4	8.78	X6.4	13.0
X3/16	6.85	X4.8	10.2
X1/8	4.75	X3.2	7.06
HSS3-1/2X3-1/2X3/8	14.6	HSS88.9X88.9X9.5	21.8
X5/16	12.7	X7.9	18.9
X1/4	10.5	X6.4	15.6
X3/16	8.13	X4.8	12.1
X1/8	5.6	X3.2	8.33
HSS3-1/2X2-1/2X3/8	12.1	HSS88.9X63.5X9.5	17.9
X5/16	10.5	X7.9	15.7
X1/4	8.78	X6.4	13.0
X3/16	6.85	X4.8	10.2
X1/8	4.75	X3.2	7.06

**Table 4h (Continued)**

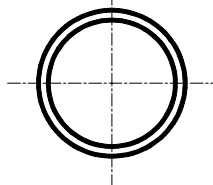
Dimensions for Rectangular  
and Square HSS



<b>U.S. Customary Units</b>		<b>Metric Units</b>	
Nominal Outside Dimensions (in) x Nominal Thickness (in)	Nominal Weight (lb/ft)	Nominal Outside Dimensions (mm) x Nominal Thickness (mm)	Nominal Weight (kg/m)
HSS3X3X3/8	12.1	HSS76.2X76.2X9.5	17.9
X5/16	10.5	X7.9	15.7
X1/4	8.78	X6.4	13.0
X3/16	6.85	X4.8	10.2
X1/8	4.75	X3.2	7.06
HSS3X2-1/2X5/16	9.46	HSS76.2X63.5X7.9	14.1
X1/4	7.93	X6.4	11.8
X3/16	6.21	X4.8	9.25
X1/8	4.32	X3.2	6.43
HSS3X2X5/16	8.4	HSS76.2X50.8X7.9	12.5
X1/4	7.08	X6.4	10.5
X3/16	5.57	X4.8	8.30
X1/8	3.9	X3.2	5.79
HSS3X1-1/2X1/4	6.23	HSS76.2X38.1X6.4	9.27
X3/16	4.94	X4.8	7.34
X1/8	3.47	X3.2	5.16
HSS3X1X1/8	3.04	HSS76.2X25.4X3.2	4.53
HSS2-1/2X2-1/2X5/16	8.4	HSS63.5X63.5X7.9	12.5
X1/4	7.08	X6.4	10.5
X3/16	5.57	X4.8	8.30
X1/8	3.9	X3.2	5.79
HSS2-1/2X1-1/2X1/4	5.38	HSS63.5X38.1X6.4	7.99
X3/16	4.3	X4.8	6.39
X1/8	3.04	X3.2	4.53
HSS2-1/4X2-1/4X1/4	6.23	HSS57.2X57.2X6.4	9.27
X3/16	4.94	X4.8	7.34
X1/8	3.47	X3.2	5.16
HSS2X2X1/4	5.38	HSS50.8X50.8X6.4	7.99
X3/16	4.3	X4.8	6.39
X1/8	3.04	X3.2	4.53
HSS2X1-1/2X3/16	3.66	HSS50.8X38.1X4.8	5.44
HSS2X1X3/16	3.02	HSS50.8X25.4X4.8	4.50
X1/8	2.19	X3.2	3.26
HSS1-3/4X1-3/4X3/16	3.66	HSS44.5X44.5X4.8	5.44
HSS1-5/8X1-5/8X3/16	3.34	HSS41.3X41.3X4.8	4.97
X1/8	2.41	X3.2	3.58
HSS1-1/2X1-1/2X3/16	3.02	HSS38.1X38.1X4.8	4.50
X1/8	2.19	X3.2	3.26
HSS1-1/4X1-1/4X3/16	2.38	HSS31.8X31.8X4.8	3.55
X1/8	1.77	X3.2	2.63



**Table 4i**  
Dimensions for Round HSS



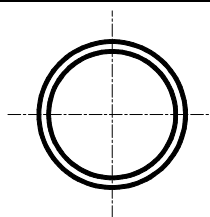
<b>U.S. Customary Units</b>		<b>Metric Units</b>	
Nominal Outside Diameter (in) x Nominal Thickness (in)	Nominal Weight (lb/ft)	Nominal Outside Diameter (mm) x Nominal Thickness (mm)	Nominal Weight (kg/m)
HSS20.000X0.500	104	HSS508X12.7	154.9
X0.375	78.7	X9.5	117.2
HSS18.000X0.500	93.5	HSS457.2X12.7	139.7
X0.375	70.7	X9.5	105.0
HSS16.000X0.500	82.8	HSS406.4X12.7	123.3
X0.438	72.9	X11.1	108.1
X0.375	62.6	X9.5	93.2
X0.312	52.3	X7.9	77.9
HSS14.000X0.500	72.2	HSS355.6X12.7	107.0
X0.375	54.6	X9.5	81.2
X0.312	45.7	X7.9	67.9
HSS12.750X0.500	65.5	HSS323.9X12.7	97.5
X0.375	49.6	X9.5	73.8
X0.250	33.4	X6.4	49.7
HSS12.500X0.625	79.3	HSS317.5X15.9	118.2
X0.500	64.1	X12.7	95.4
X0.375	48.6	X9.5	72.3
X0.312	40.7	X7.9	60.4
X0.250	32.7	X6.4	48.7
X0.188	24.7	X4.8	36.8
HSS11.250X0.625	71	HSS285.8X15.9	106.0
X0.500	57.5	X12.7	85.5
X0.375	43.6	X9.5	64.8
X0.312	36.5	X7.9	54.2
X0.250	29.4	X6.4	43.7
X0.188	22.2	X4.8	33.0
HSS10.750X0.500	54.8	HSS273.1X12.7	81.5
X0.250	28.1	X6.4	41.8
HSS10.000X0.625	62.6	HSS254X15.9	93.2
X0.500	50.8	X12.7	75.5
X0.375	38.6	X9.5	57.4
X0.312	32.3	X7.9	48.1
X0.250	26.1	X6.4	38.7
X0.188	19.7	X4.8	29.4





**Table 4i (Continued)**

Dimensions for Round HSS

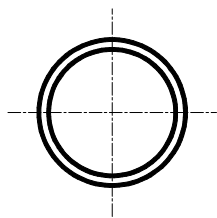


<b>U.S. Customary Units</b>		<b>Metric Units</b>	
Nominal Outside Diameter (in) x Nominal Thickness (in)	Nominal Weight (lb/ft)	Nominal Outside Diameter (mm) x Nominal Thickness (mm)	Nominal Weight (kg/m)
HSS9.625X0.500	48.8	HSS244.5X12.7	72.6
X0.375	37.1	X9.5	55.1
X0.312	31.1	X7.9	46.2
X0.250	25.1	X6.4	37.3
X0.188	19	X4.8	28.2
HSS8.750X0.500	44.1	HSS222.3X12.7	65.6
X0.375	33.6	X9.5	49.9
X0.312	28.1	X7.9	41.9
X0.250	22.7	X6.4	33.8
X0.188	17.2	X4.8	25.6
HSS8.625X0.500	43.4	HSS219.1X12.7	64.6
X0.375	33.1	X9.5	49.2
X0.322	28.6	X8.2	42.5
X0.250	22.4	X6.4	33.3
X0.188	17	X4.8	25.2
HSS7.625X0.125	10	HSS193.7X3.2	14.9
HSS7.500X0.500	37.4	HSS190.5X12.7	55.7
X0.375	28.6	X9.5	42.5
X0.312	24	X7.9	35.7
X0.250	19.4	X6.4	28.8
X0.188	14.7	X4.8	21.8
HSS7.000X0.500	34.7	HSS177.8X12.7	51.7
X0.375	26.6	X9.5	39.6
X0.312	22.3	X7.9	33.2
X0.250	18	X6.4	26.8
X0.188	13.7	X4.8	20.4
X0.125	9.19	X3.2	13.7
HSS6.875X0.500	34.1	HSS174.6X12.7	50.7
X0.375	26.1	X9.5	38.7
X0.312	21.9	X7.9	32.5
X0.250	17.7	X6.4	26.3
X0.188	13.4	X4.8	20.0
HSS6.625X0.500	32.7	HSS168.3X12.7	48.7
X0.432	28.6	X11	42.5
X0.375	25.1	X9.5	37.3
X0.312	21.1	X7.9	31.3
X0.280	19	X7.1	28.2
X0.250	17	X6.4	25.4
X0.188	12.9	X4.8	19.3
X0.125	8.69	X3.2	12.9



**Table 4i (Continued)**

Dimensions for Round HSS

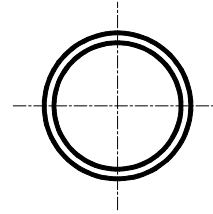


<b>U.S. Customary Units</b>		<b>Metric Units</b>	
Nominal Outside Diameter (in) x Nominal Thickness (in)	Nominal Weight (lb/ft)	Nominal Outside Diameter (mm) x Nominal Thickness (mm)	Nominal Weight (kg/m)
HSS6.125X0.500	30.1	HSS155.6X12.7	44.8
X0.375	23.1	X9.5	34.3
X0.312	19.4	X7.9	28.8
X0.250	15.7	X6.4	23.3
X0.188	11.9	X4.8	17.7
HSS6.000X0.500	29.4	HSS152.4X12.7	43.7
X0.375	22.5	X9.5	33.5
X0.312	19	X7.9	28.2
X0.280	17.1	X7.1	25.5
X0.250	15.4	X6.4	22.8
X0.188	11.7	X4.8	17.3
X0.125	7.85	X3.2	11.7
HSS5.563X0.375	20.8	HSS141.3X9.5	31.0
X0.258	14.6	X6.6	21.8
X0.188	10.8	X4.8	16.1
X0.134	7.78	X3.4	11.5
HSS5.500X0.500	26.7	HSS139.7X12.7	39.8
X0.375	20.5	X9.5	30.6
X0.258	14.5	X6.6	21.5
HSS5.000X0.500	24.1	HSS127X12.7	35.8
X0.375	18.5	X9.5	27.6
X0.312	15.6	X7.9	23.2
X0.258	13.1	X6.6	19.5
X0.250	12.7	X6.4	18.9
X0.188	9.67	X4.8	14.4
X0.125	6.51	X3.2	9.7
HSS4.500X0.337	15	HSS114.3X8.6	22.3
X0.237	10.8	X6	16.1
X0.188	8.67	X4.8	12.8
X0.125	5.85	X3.2	8.7
HSS4.000X0.337	13.2	HSS101.6X8.6	19.7
X0.313	12.3	X8	18.3
X0.250	10	X6.4	14.9
X0.237	9.53	X6	14.2
X0.226	9.12	X5.7	13.6
X0.220	8.89	X5.6	13.3
X0.188	7.66	X4.8	11.4
X0.125	5.18	X3.2	7.7



**Table 4i (Continued)**

Dimensions for Round HSS

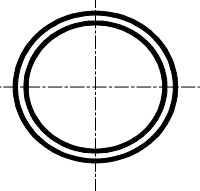


<b>U.S. Customary Units</b>		<b>Metric Units</b>	
Nominal Outside Diameter (in) x Nominal Thickness (in)	Nominal Weight (lb/ft)	Nominal Outside Diameter (mm) x Nominal Thickness (mm)	Nominal Weight (kg/m)
HSS3.500X0.313	10.7	HSS88.9X8	15.9
X0.300	10.3	X7.6	15.3
X0.250	8.69	X6.4	12.9
X0.216	7.58	X5.5	11.3
X0.203	7.15	X5.2	10.6
X0.188	6.66	X4.8	9.9
X0.125	4.51	X3.2	6.7
HSS3.000X0.300	8.66	HSS76.2X7.6	12.8
X0.250	7.35	X6.4	10.9
X0.216	6.43	X5.5	9.6
X0.203	6.07	X5.2	9.0
X0.188	5.65	X4.8	8.4
X0.152	4.63	X3.9	6.9
X0.134	4.11	X3.4	6.1
X0.120	3.69	X3	5.5
HSS2.875X0.250	7.02	HSS73X6.4	10.4
X0.203	5.8	X5.2	8.6
X0.188	5.4	X4.8	8.0
X0.125	3.67	X3.2	5.5
HSS2.500X0.250	6.01	HSS63.5X6.4	9.0
X0.188	4.65	X4.8	6.9
X0.125	3.17	X3.2	4.7
HSS2.375X0.250	5.68	HSS60.3X6.4	8.5
X0.218	5.03	X5.5	7.5
X0.188	4.4	X4.8	6.5
X0.154	3.66	X3.9	5.4
X0.125	3.01	X3.2	4.5
HSS1.900X0.145	2.72	HSS48.3X3.7	4.0
HSS1.660X0.140	2.27	HSS42.2X3.6	3.4



**Table 4j**

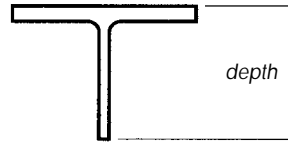
Dimensions for Pipes



U.S. Customary Units					Metric Units				
Nominal Diameter (in)	Nominal Weight (lb/ft)	Outside Diameter (in)	Inside Diameter (in)	Wall Thickness (in)	Nominal Diameter (mm)	Nominal Weight (kg/m)	Outside Diameter (mm)	Inside Diameter (mm)	Wall Thickness (mm)
<b>Standard</b>					<b>Standard</b>				
1/2	0.852	0.840	0.622	0.109	13	0.0124	21.3	15.8	2.8
3/4	1.13	1.05	0.824	0.113	19	0.0165	26.7	20.9	2.9
1	1.68	1.32	1.05	0.133	25	0.0245	33.4	26.6	3.4
1-1/4	2.27	1.66	1.38	0.140	32	0.0332	42.2	35.1	3.6
1-1/2	2.72	1.90	1.61	0.145	38	0.0397	48.3	40.9	3.7
2	3.66	2.38	2.07	0.154	51	0.0534	60.3	52.5	3.9
2-1/2	5.80	2.88	2.47	0.203	64	0.0846	73.0	62.7	5.2
3	7.58	3.50	3.07	0.216	75	0.111	88.9	77.9	5.5
3-1/2	9.12	4.00	3.55	0.226	89	0.133	102	90.1	5.7
4	10.8	4.50	4.03	0.237	102	0.158	114	102	6.0
5	14.6	5.56	5.05	0.258	127	0.214	141	128	6.6
6	19.0	6.63	6.07	0.280	152	0.277	168	154	7.1
8	28.6	8.63	7.98	0.322	203	0.417	219	203	8.2
10	40.5	10.8	10.0	0.365	254	0.591	273	255	9.3
12	49.6	12.8	12.0	0.375	310	0.724	324	305	9.5
<b>Extra Strong</b>					<b>Extra Strong</b>				
1/2	1.09	0.840	0.546	0.147	13	0.0159	21.3	13.9	3.7
3/4	1.48	1.05	0.742	0.154	19	0.0215	26.7	18.8	3.9
1	2.17	1.32	0.957	0.179	25	0.0317	33.4	24.3	4.5
1-1/4	3.00	1.66	1.28	0.191	32	0.0438	42.2	32.5	4.9
1-1/2	3.63	1.90	1.50	0.200	38	0.053	48.3	38.1	5.1
2	5.03	2.38	1.94	0.218	51	0.0734	60.3	49.3	5.5
2-1/2	7.67	2.88	2.32	0.276	64	0.112	73.0	59.0	7.0
3	10.3	3.50	2.90	0.300	75	0.15	88.9	73.7	7.6
3-1/2	12.5	4.00	3.36	0.318	89	0.183	102	85.4	8.1
4	15.0	4.50	3.83	0.337	102	0.219	114	97.2	8.6
5	20.8	5.56	4.81	0.375	127	0.304	141	122	9.5
6	28.6	6.63	5.76	0.432	152	0.417	168	146	11.0
8	43.4	8.63	7.63	0.500	203	0.634	219	194	12.7
10	54.8	10.8	9.75	0.500	254	0.8	273	248	12.7
12	65.5	12.8	11.8	0.500	310	0.956	324	298	12.7
<b>Double-Extra Strong</b>					<b>Double-Extra Strong</b>				
2	9.04	2.38	1.50	0.436	51	0.132	60.3	38.2	11.1
2-1/2	13.7	2.88	1.77	0.552	64	0.200	73.0	45.0	14.0
3	18.6	3.5	2.30	0.6	75	0.271	88.9	58.4	15.2
4	27.6	4.5	3.15	0.674	102	0.402	114	80.1	17.1
5	38.6	5.56	4.06	0.75	127	0.563	141	103	19.1
6	53.2	6.63	4.90	0.864	152	0.777	168	124	21.9
8	72.5	8.63	6.88	0.875	203	1.06	219	175	22.2

**Table 4k**

WT-Shapes (Split from W-Shapes)

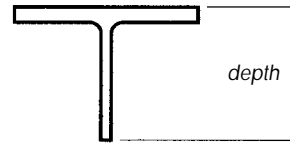


U.S. Customary Units				Metric Units			
nominal depth (in)	Split From	nominal depth (in)	Split From	nominal depth (mm)	Split From	nominal depth (mm)	Split From
x nominal weight (lb/ft)		x nominal weight (lb/ft)		x nominal weight (kg/m)		x nominal weight (kg/m)	
WT22X167.5	W44X335	WT16.5X193.5	W33X387	WT550X249.5	W1100X499	WT420X288	W840X576
X145	X290	X177	X354	X216.5	X433	X249	X527
X131	X262	X159	X318	X195	X390	X236.5	X473
X115	X230	X145.5	X291	X171.5	X343	X216.5	X433
		X131.5	X263			X196	X392
WT20X296.5	W40X593	X120.5	X241	WT500X441.5	W1000X883	X179.5	X359
X251.5	X503	X110.5	X221	X374	X748	X164.5	X329
X215.5	X431	X100.5	X201	X321	X642	X149.5	X299
X198.5	X397	X84.5	X169	X295.5	X591	X125.5	X251
X186	X372	X76	X152	X277	X554	X113	X226
X181	X362	X70.5	X141	X269.5	X539	X105	X210
X162	X324	X65	X130	X241.5	X483	X96.5	X193
X148.5	X297	X59	X118	X221.5	X443	X88	X176
X138.5	X277			X206	X412		
X124.5	X249	WT15X195.5	W30X391	X185.5	X371	WT380X291	W760X582
X107.5	X215	X178.5	X357	X160.5	X321	X265.5	X531
X99.5	X199	X163	X326	X148	X296	X242	X484
X196	X392	X146	X292	X292	X584	X217	X434
X165.5	X331	X130.5	X261	X247	X494	X194.5	X389
X163.5	X327	X117.5	X235	X243	X486	X175	X350
X139	X278	X105.5	X211	X207.5	X415	X157	X314
X132	X264	X95.5	X191	X196.5	X393	X142	X284
X117.5	X235	X86.5	X173	X175	X350	X128.5	X257
X105.5	X211	X74	X148	X157	X314	X110	X220
X91.5	X183	X66	X132	X136	X272	X98	X196
X83.5	X167	X62	X124	X124.5	X249	X92.5	X185
X74.5	X149	X58	X116	X111	X222	X86.5	X173
		X54	X108			X80.5	X161
WT18X399	W36X798	X49.5	X99	WT460X594	W920X1188	X73.5	X147
X325	X650	X45	X90	X483.5	X967	X67	X134
X263.5	X527			X392	X784		
X219.5	X439	WT13.5X269.5	W27X539	X326.5	X653	WT345X401	W690X802
X196.5	X393	X184	X368	X292.5	X585	X274	X548
X179.5	X359	X168	X336	X267	X534	X250	X500
X164	X328	X153.5	X307	X244	X488	X228.5	X457
X150	X300	X140.5	X281	X223	X446	X209.5	X419
X140	X280	X129	X258	X208.5	X417	X192	X384
X130	X260	X117.5	X235	X193.5	X387	X175	X350
X122.5	X245	X108.5	X217	X182.5	X365	X161.5	X323
X115	X230	X97	X194	X171	X342	X144.5	X289
X128	X256	X89	X178	X190.5	X381	X132.5	X265
X116	X232	X80.5	X161	X172.5	X345	X120	X240
X105	X210	X73	X146	X156.5	X313	X108.5	X217
X97	X194	X64.5	X129	X144.5	X289	X96	X192
X91	X182	X57	X114	X135.5	X271	X85	X170
X85	X170	X51	X102	X126.5	X253	X76	X152
X80	X160	X47	X94	X119	X238	X70	X140
X75	X150	X42	X84	X111.5	X223	X62.5	X125
X67.5	X135			X100.5	X201		



**Table 4k (Continued)**

WT-Shapes (Split from W-Shapes)

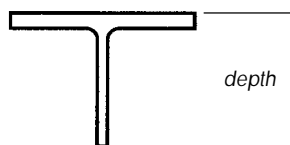


U.S. Customary Units				Metric Units			
nominal depth (in)	Split From	nominal depth (in)	Split From	nominal depth (mm)	Split From	nominal depth (mm)	Split From
x nominal weight (lb/ft)		x nominal weight (lb/ft)		x nominal weight (kg/m)		x nominal weight (kg/m)	
WT12X185	W24X370	WT9X35.5	W18X71	WT305X275.5	W610X551	WT230X53	W460X106
X167.5	X335	X32.5	X65	X249	X498	X48.5	X97
X153	X306	X30	X60	X227.5	X455	X44.5	X89
X139.5	X279	X27.5	X55	X207.5	X415	X41	X82
X125	X250	X25	X50	X186	X372	X37	X74
X114.5	X229	X23	X46	X170.5	X341	X34	X68
X103.5	X207	X20	X40	X153.5	X307	X30	X60
X96	X192	X17.5	X35	X142.5	X285	X26	X52
X88	X176			X131	X262		
X81	X162	WT8X50	W16X100	X120.5	X241	WT205X74.5	W410X149
X73	X146	X44.5	X89	X108.5	X217	X66	X132
X65.5	X131	X38.5	X77	X97.5	X195	X57	X114
X58.5	X117	X33.5	X67	X87	X174	X50	X100
X52	X104	X28.5	X57	X77.5	X155	X42.5	X85
X51.5	X103	X25	X50	X76.5	X153	X37.5	X75
X47	X94	X22.5	X45	X70	X140	X33.5	X67
X42	X84	X20	X40	X62.5	X125	X30	W410X60
X38	X76	X18	X36	X56.5	X113	X26.5	X53
X34	X68	X15.5	X31	X50.5	X101	X23.05	X46.1
X31	X62	X13	X26	X46	X92	X19.4	X38.8
X27.5	X55			X41	X82		
		WT7X404	W14X808			WT180X601	W360X1202
WT10.5X100.5	W21X201	X365	X730	WT265X150	W530X300	X543	X1086
X91	X182	X332.5	X665	X136	X272	X495	X990
X83	X166	X302.5	X605	X124	X248	X450	X900
X73.5	X147	X275	X550	X109.5	W530X219	X409	X818
X66	X132	X250	X500	X98	X196	X372	X744
X61	X122	X227.5	X455	X91	X182	X338.5	X677
X55.5	X111	X213	X426	X82.5	X165	X317	X634
X50.5	X101	X199	X398	X75	X150	X296	X592
X46.5	X93	X185	X370	X69	X138	X275.5	X551
X41.5	X83	X171	X342	X61.5	X123	X254.5	X509
X36.5	X73	X155.5	X311	X54.5	X109	X231.5	X463
X34	X68	X141.5	X283	X50.5	X101	X210.5	X421
X31	X62	X128.5	X257	X46	X92	X191	X382
X27.5	X55	X116.5	X233	X41	X82	X173.5	X347
X24	X48	X105.5	X211	X36	X72	X157	X314
X28.5	X57	X96.5	X193	X42.5	X85	X143.5	X287
X25	X50	X88	X176	X37	X74	X131	X262
X22	X44	X79.5	X159	X33	X66	X118.5	X237
		X72.5	X145			X108	X216
WT9X87.5	W18X175	X66	X132	WT230X130	W460X260	X98	X196
X79	X158	X60	X120	X117.5	X235	X89.5	X179
X71.5	X143	X54.5	X109	X106.5	X213	X81	X162
X65	X130	X49.5	X99	X96.5	X193	X73.5	X147
X59.5	X119	X45	X90	X88.5	X177	X67	X134
X53	X106	X41	X82	X79	X158	X61	X122
X48.5	X97	X37	X74	X72	X144	X55	X110
X43	X86	X34	X68	X64	X128	X50.5	X101
X38	X76	X30.5	X61	X56.5	X113	X45.5	X91



**Table 4k (Continued)**

WT-Shapes (Split from W-Shapes)



U.S. Customary Units				Metric Units			
nominal depth (in)	Split From	nominal depth (in)	Split From	nominal depth (mm)	Split From	nominal depth (mm)	Split From
x nominal weight (lb/ft)		x nominal weight (lb/ft)		x nominal weight (kg/m)		x nominal weight (kg/m)	
WT7X26.5	W14X53	WT5X15	W10X30	WT180X39.5	W360X79	WT125X22.4	W250X44.8
X24	X48	X13	X26	X36	X72	X19.25	X38.5
X21.5	X43	X11	X22	X32	X64	X16.35	X32.7
X19	X38	X9.5	X19	X28.9	X57.8	X14.2	X28.4
X17	X34	X8.5	X17	X25.5	X51	X12.65	X25.3
X15	X30	X7.5	X15	X22	X44	X11.15	X22.3
X13	X26	X6	X12	X19.5	X39	X8.95	X17.9
X11	X22			X16.45	X32.9		
		WT4X33.5	W8X67			WT100X50	W200X100
WT6X168	W12X336	X29	X58	WT155X250	W310X500	X43	X86
X152.5	X305	X24	X48	X227	X454	X35.5	X71
X139.5	X279	X20	X40	X207.5	X415	X29.5	X59
X126	X252	X17.5	X35	X187.5	X375	X26	X52
X115	X230	X15.5	X31	X171	X342	X23.05	X46.1
X105	X210	X14	X28	X156.5	X313	X20.85	X41.7
X95	X190	X12	X24	X141.5	X283	X17.95	X35.9
X85	X170	X10.5	X21	X126.5	X253	X15.65	X31.3
X76	X152	X9	X18	X113	X226	X13.3	X26.6
X68	X136	X7.5	X15	X101	X202	X11.25	X22.5
X60	X120	X6.5	X13	X89.5	X179	X9.65	X19.3
X53	X106	X5	X10	X79	X158	X7.5	X15
X48	X96			X71.5	X143		
X43.5	X87	WT3X12.5	W6X25	X64.5	X129	WT75X18.55	W150X37.1
X39.5	X79	X10	X20	X58.5	X117	X14.9	X29.8
X36	X72	X7.5	X15	X53.5	X107	X11.25	X22.5
X32.5	X65	X8	X16	X48.5	X97	X12	X24
X29	X58	X6	X12	X43	X86	X9	X18
X26.5	X53	X4.5	X9	X39.5	X79	X6.75	X13.5
X25	X50	X4.25	X8.5	X37	X74	X6.5	X13
X22.5	X45			X33.5	X67		
X20	X40	WT2.5X9.5	W5X19	X30	X60	WT65X14.05	W130X28.1
X17.5	X35	X8	X16	X26	X52	X11.9	X23.8
X15	X30			X22.25	X44.5		
X13	X26	WT2X6.5	W4X13	X19.35	X38.7	WT50X9.65	W100X19.3
X11	X22			X16.35	X32.7		
X9.5	X19			X14.15	X28.3		
X8	X16			X11.9	X23.8		
X7	X14			X10.5	X21		
WT5X56	W10X112			WT125X83.5	W250X167		
X50	X100			X74.5	X149		
X44	X88			X65.5	X131		
X38.5	X77			X57.5	X115		
X34	X68			X50.5	X101		
X30	X60			X44.5	X89		
X27	X54			X40	X80		
X24.5	X49			X36.5	W250X73		
X22.5	X45			X33.5	X67		
X19.5	X39			X29	X58		
X16.5	X33			X24.55	X49.1		



<b>Table 4l</b>			
MT-Shapes (Split from M-Shapes)			
U.S. Customary Units		Metric Units	
nominal depth (in) x nominal weight (lb/ft)	Split From	nominal depth (mm) x nominal weight (kg/m)	Split From
MT6X5.9 X5.4 X5	M12X11.8 X10.8 X10	MT155X8.8 X8.05 X7.45	M310X17.6 X16.1 X14.9
MT5X4.5 X4 X3.75	M10X9 X8 X7.5	MT125X6.7 X5.95 X5.6	M250X13.4 X11.9 X11.2
MT4X3.25 X3.1	M8X6.5 X6.2	MT100X4.85 X4.6	M200X9.7 X9.2
MT3X2.2 X1.85	M6X4.4 X3.7	MT75X3.3 X2.75	M150X6.6 X5.5
MT2.5X9.45	M5X18.9	MT65X14.05	M130X28.1
MT2X3	M4X6	MT50X4.45	M100X8.9

<b>Table 4m</b>							
ST-Shapes (Split from S-Shapes)							
U.S. Customary Units				Metric Units			
nominal depth (in) x nominal weight (lb/ft)	Split From	nominal depth (in) x nominal weight (lb/ft)	Split From	nominal depth (mm) x nominal weight (kg/m)	Split From	nominal depth (mm) x nominal weight (kg/m)	Split From
ST12X60.5 X53 X50 X45 X40	S24X121 X106 X100 X90 X80	ST6X17.5 X15.9	S12X35 X31.8	ST305X90 X79 X74.5 X67 X59.5	S610X180 X158 X149 X134 X119	ST155X26 X23.65	S310X52 X47.3
ST10X48 X43 X37.5 X33	S20X96 X86 X75 X66	ST5X17.5 X12.7	S10X35 X25.4	ST255X71.5 X64 X56 X49.1	S510X143 X128 X112 X98.2	ST125X26 X18.9	S250X52 X37.8
ST9X35 X27.35	S18X70 X54.7	ST4X11.5 X9.2	S8X23 X18.4	ST230X52 X40.7	S460X104 X81.4	ST100X17 X13.7	S200X34 X27.4
ST7.5X25 X21.45	S15X50 X42.9	ST3X8.63 X6.25	S6X17.25 X12.5	ST190X37 X32	S380X74 X64	ST75X12.85 X9.3	S150X25.7 X18.6
ST6X25 X20.4	S12X50 X40.8	ST2.5X5	S5X10	ST155X37 X30.35	S310X74 X60.7	ST65X7.5	S130X15
		ST2X4.75 X3.85	S4X9.5 X7.7			ST50X7.05 X5.75	S100X14.1 X11.5
		ST1.5X3.75 X2.85	S3X7.5 X5.7			ST37.5X5.6 X4.25	S75X11.2 X8.5





**Table 5a**

Surface and Box Perimeters, Surface Areas and Weight-to-Perimeter Ratios for W-Shapes

Shape	Case A (See Fig. 1, Pg. 88)			Case B (See Fig. 1, Pg. 88)			Case C (See Fig. 1, Pg. 88)			Case D (See Fig. 1, Pg. 88)		
	Peri- meter	W/D Ratio	Surf. Area	Peri- meter	W/D Ratio	Surf. Area	Peri- meter	W/D Ratio	Surf. Area	Peri- meter	W/D Ratio	Surf. Area
	in.		ft <sup>2</sup> /ft	in.		ft <sup>2</sup> /ft	in.		ft <sup>2</sup> /ft	in.		ft <sup>2</sup> /ft
W44x335	133	2.52	11.1	149	2.25	12.4	104	3.22	8.67	120	2.79	10.0
x290	132	2.20	11.0	147	1.97	12.3	103	2.82	8.58	119	2.44	9.92
x262	131	2.00	10.9	147	1.78	12.3	102	2.57	8.50	118	2.22	9.83
x230	130	1.77	10.8	146	1.58	12.2	102	2.25	8.50	117	1.97	9.75
W40x593	130	4.56	10.8	147	4.03	12.3	103	5.76	8.58	119	4.98	9.92
x503	128	3.93	10.7	144	3.49	12.0	101	4.98	8.42	117	4.30	9.75
x431	126	3.42	10.5	143	3.01	11.9	98.8	4.36	8.23	115	3.75	9.58
x397	126	3.15	10.5	142	2.80	11.8	98.1	4.05	8.18	114	3.48	9.50
x372	125	2.98	10.4	141	2.64	11.8	97.3	3.82	8.11	113	3.29	9.42
x362	125	2.90	10.4	141	2.57	11.8	97.2	3.72	8.10	113	3.20	9.42
x324	124	2.61	10.3	140	2.31	11.7	96.3	3.36	8.03	112	2.89	9.33
x297	123	2.41	10.3	139	2.14	11.6	95.4	3.11	7.95	111	2.68	9.25
x277	123	2.25	10.3	139	1.99	11.6	95.2	2.91	7.93	111	2.50	9.25
x249	123	2.02	10.3	139	1.79	11.6	94.6	2.63	7.88	110	2.26	9.17
x215	122	1.76	10.2	138	1.56	11.5	93.8	2.29	7.82	110	1.95	9.17
x199	121	1.64	10.1	137	1.45	11.4	93.2	2.14	7.77	109	1.83	9.08
W40x392	116	3.38	9.67	128	3.06	10.7	95.6	4.10	7.97	108	3.63	9.00
x331*	114	2.90	9.50	126	2.63	10.5	93.8	3.53	7.82	106	3.12	8.83
x327	113	2.89	9.42	125	2.62	10.4	93.7	3.49	7.81	106	3.08	8.83
x278	112	2.48	9.33	124	2.24	10.3	92.4	3.01	7.70	104	2.67	8.67
x264	112	2.36	9.33	124	2.13	10.3	91.9	2.87	7.66	104	2.54	8.67
x235	112	2.10	9.33	124	1.90	10.3	91.3	2.57	7.61	103	2.28	8.58
x211	111	1.90	9.25	123	1.72	10.3	90.6	2.33	7.55	102	2.07	8.50
x183	110	1.66	9.17	122	1.50	10.2	89.8	2.04	7.48	102	1.79	8.50
x167	109	1.53	9.08	121	1.38	10.1	89.0	1.88	7.42	101	1.65	8.42
x149	109	1.37	9.08	121	1.23	10.1	88.2	1.69	7.35	100	1.49	8.33
W36x798	131	6.09	10.9	149	5.36	12.4	102	7.82	8.50	120	6.65	10.0
x650	128	5.08	10.7	146	4.45	12.2	98.6	6.59	8.22	116	5.60	9.67
x527	125	4.22	10.4	142	3.71	11.8	95.6	5.51	7.97	113	4.66	9.42
x439	123	3.57	10.3	140	3.14	11.7	93.6	4.69	7.80	111	3.95	9.25
x393	121	3.25	10.1	138	2.85	11.5	92.4	4.25	7.70	109	3.61	9.08
x359	121	2.97	10.1	137	2.62	11.4	91.5	3.92	7.63	108	3.32	9.00
x328	120	2.73	10.0	137	2.39	11.4	90.8	3.61	7.57	107	3.07	8.92
x300	120	2.50	10.0	136	2.21	11.3	90.1	3.33	7.51	107	2.80	8.92
x280	119	2.35	9.92	136	2.06	11.3	89.6	3.13	7.47	106	2.64	8.83
x260	119	2.18	9.92	135	1.93	11.3	89.2	2.91	7.43	106	2.45	8.83
x245	118	2.08	9.83	135	1.81	11.3	88.7	2.76	7.39	105	2.33	8.75
x230	118	1.95	9.83	134	1.72	11.2	88.3	2.60	7.36	105	2.19	8.75

Case A: Shape perimeter, minus one flange surface.

Case C: Box perimeter, minus one flange surface.

Case B: Shape perimeter.

Case D: Box perimeter.



**Table 5a (Continued)**

Surface and Box Perimeters, Surface Areas and Weight-to-Perimeter Ratios for W-Shapes

Shape	Case A (See Fig. 1, Pg. 88)			Case B (See Fig. 1, Pg. 88)			Case C (See Fig. 1, Pg. 88)			Case D (See Fig. 1, Pg. 88)		
	Peri- meter	W/D Ratio	Surf. Area	Peri- meter	W/D Ratio	Surf. Area	Peri- meter	W/D Ratio	Surf. Area	Peri- meter	W/D Ratio	Surf. Area
	in.		ft <sup>2</sup> /ft	in.		ft <sup>2</sup> /ft	in.		ft <sup>2</sup> /ft	in.		ft <sup>2</sup> /ft
W36x256	108	2.37	9.00	120	2.13	10.0	87.0	2.94	7.25	99.2	2.58	8.27
x232	108	2.15	9.00	120	1.93	10.0	86.3	2.69	7.19	98.4	2.36	8.20
x210	107	1.96	8.92	119	1.76	9.92	85.6	2.45	7.13	97.8	2.15	8.15
x194	107	1.81	8.92	119	1.63	9.92	85.1	2.28	7.09	97.2	2.00	8.10
x182	106	1.72	8.83	119	1.53	9.92	84.7	2.15	7.06	96.8	1.88	8.07
x170	106	1.60	8.83	118	1.44	9.83	84.4	2.01	7.03	96.4	1.76	8.03
x160	106	1.51	8.83	118	1.36	9.83	84.0	1.90	7.00	96.0	1.67	8.00
x150	105	1.43	8.75	117	1.28	9.75	83.8	1.79	6.98	95.8	1.57	7.98
x135	105	1.29	8.75	117	1.15	9.75	83.2	1.62	6.93	95.2	1.42	7.93
W33x387	117	3.31	9.75	133	2.91	11.1	88.2	4.39	7.35	104	3.72	8.67
x354*	116	3.05	9.67	132	2.68	11.0	87.3	4.05	7.28	103	3.44	8.58
x318*	115	2.77	9.58	131	2.43	10.9	86.4	3.68	7.20	102	3.12	8.50
x291	114	2.55	9.50	130	2.24	10.8	85.5	3.40	7.13	101	2.88	8.42
x263	113	2.33	9.42	129	2.04	10.8	84.8	3.10	7.07	101	2.60	8.42
x241	113	2.13	9.42	129	1.87	10.8	84.3	2.86	7.03	100	2.41	8.33
x221	112	1.97	9.33	128	1.73	10.7	83.6	2.64	6.97	99.4	2.22	8.28
x201	112	1.79	9.33	127	1.58	10.6	83.1	2.42	6.93	98.8	2.03	8.23
W33x169	99.6	1.70	8.30	111	1.52	9.25	79.1	2.14	6.59	90.6	1.87	7.55
x152	99.3	1.53	8.28	111	1.37	9.25	78.6	1.93	6.55	90.2	1.69	7.52
x141	98.4	1.43	8.20	110	1.28	9.17	78.1	1.81	6.51	89.6	1.57	7.47
x130	98.3	1.32	8.19	110	1.18	9.17	77.7	1.67	6.48	89.2	1.46	7.43
x118	97.8	1.21	8.15	109	1.08	9.08	77.3	1.53	6.44	88.8	1.33	7.40
W30x391	109	3.59	9.08	125	3.13	10.4	82.0	4.77	6.83	97.6	4.01	8.13
x357	108	3.31	9.00	124	2.88	10.3	81.1	4.40	6.76	96.6	3.70	8.05
x326	107	3.05	8.92	123	2.65	10.3	80.2	4.06	6.68	95.6	3.41	7.97
x292	107	2.73	8.92	122	2.39	10.2	79.3	3.68	6.61	94.6	3.09	7.88
x261	106	2.46	8.83	121	2.16	10.1	78.4	3.33	6.53	93.6	2.79	7.80
x235	105	2.24	8.75	120	1.96	10.00	77.7	3.02	6.48	92.8	2.53	7.73
x211	105	2.01	8.75	120	1.76	10.00	76.9	2.74	6.41	92.0	2.29	7.67
x191	103	1.85	8.58	118	1.62	9.83	76.4	2.50	6.37	91.4	2.09	7.62
x173	104	1.66	8.67	119	1.45	9.92	75.8	2.28	6.32	90.8	1.91	7.57
W30x148	90.3	1.64	7.53	101	1.47	8.42	71.9	2.06	5.99	82.4	1.80	6.87
x132	89.5	1.47	7.46	100	1.32	8.33	71.1	1.86	5.93	81.6	1.62	6.80
x124	89.3	1.39	7.44	99.8	1.24	8.32	70.9	1.75	5.91	81.4	1.52	6.78
x116	89.1	1.30	7.43	99.6	1.16	8.30	70.5	1.65	5.88	81.0	1.43	6.75
x108	88.9	1.21	7.41	99.4	1.09	8.28	70.1	1.54	5.84	80.6	1.34	6.72
x99	88.5	1.12	7.38	99.0	1.00	8.25	69.9	1.42	5.83	80.4	1.23	6.70
x90	88.0	1.02	7.33	98.4	0.915	8.20	69.4	1.30	5.78	79.8	1.13	6.65

Case A: Shape perimeter, minus one flange surface.

Case C: Box perimeter, minus one flange surface.

Case B: Shape perimeter.

Case D: Box perimeter.



**Table 5a (Continued)**

Surface and Box Perimeters, Surface Areas and Weight-to-Perimeter Ratios for W-Shapes

Shape	Case A (See Fig. 1, Pg. 88)			Case B (See Fig. 1, Pg. 88)			Case C (See Fig. 1, Pg. 88)			Case D (See Fig. 1, Pg. 88)		
	Peri- meter	W/D Ratio	Surf. Area	Peri- meter	W/D Ratio	Surf. Area	Peri- meter	W/D Ratio	Surf. Area	Peri- meter	W/D Ratio	Surf. Area
	in.		ft <sup>2</sup> /ft	in.		ft <sup>2</sup> /ft	in.		ft <sup>2</sup> /ft	in.		ft <sup>2</sup> /ft
W21x201	80.5	2.50	6.71	93.1	2.16	7.76	58.6	3.43	4.88	71.2	2.82	5.93
x182	80.0	2.28	6.67	92.5	1.97	7.71	57.9	3.14	4.83	70.4	2.59	5.87
x166	79.5	2.09	6.63	91.9	1.81	7.66	57.4	2.89	4.78	69.8	2.38	5.82
x147	78.7	1.87	6.56	91.2	1.61	7.60	56.7	2.59	4.73	69.2	2.12	5.77
x132	78.5	1.68	6.54	90.9	1.45	7.58	56.0	2.36	4.67	68.4	1.93	5.70
x122	77.9	1.57	6.49	90.3	1.35	7.53	55.8	2.19	4.65	68.2	1.79	5.68
x111	77.4	1.43	6.45	89.7	1.24	7.48	55.3	2.01	4.61	67.6	1.64	5.63
x101	77.4	1.30	6.45	89.7	1.13	7.48	55.1	1.83	4.59	67.4	1.50	5.62
W21x93	66.3	1.40	5.53	74.8	1.24	6.23	51.6	1.80	4.30	60.0	1.55	5.00
x83	65.8	1.26	5.48	74.2	1.12	6.18	51.2	1.62	4.27	59.5	1.39	4.96
x73	65.5	1.11	5.46	73.8	0.989	6.15	50.7	1.44	4.23	59.0	1.24	4.92
x68	65.1	1.04	5.43	73.4	0.926	6.12	50.5	1.35	4.21	58.7	1.16	4.89
x62	65.1	0.952	5.43	73.3	0.846	6.11	50.2	1.24	4.18	58.5	1.06	4.88
x55	64.4	0.854	5.37	72.6	0.758	6.05	49.8	1.10	4.15	58.0	0.948	4.83
x48	64.0	0.750	5.33	72.1	0.666	6.01	49.3	0.974	4.11	57.5	0.835	4.79
W21x57	59.9	0.952	4.99	66.5	0.857	5.54	48.8	1.17	4.07	55.3	1.03	4.61
x50	59.7	0.838	4.98	66.3	0.754	5.53	48.1	1.04	4.01	54.7	0.914	4.56
x44	59.0	0.746	4.92	65.5	0.672	5.46	47.9	0.919	3.99	54.4	0.809	4.53
W18x175	71.1	2.46	5.93	82.5	2.12	6.88	51.4	3.40	4.28	62.8	2.79	5.23
x158	70.5	2.24	5.88	81.8	1.93	6.82	50.7	3.12	4.23	62.0	2.55	5.17
x143	69.8	2.05	5.82	81.0	1.77	6.75	50.2	2.85	4.18	61.4	2.33	5.12
x130	69.3	1.88	5.78	80.5	1.61	6.71	49.8	2.61	4.15	61.0	2.13	5.08
x119	69.2	1.72	5.77	80.5	1.48	6.71	49.3	2.41	4.11	60.6	1.96	5.05
x106	68.6	1.55	5.72	79.8	1.33	6.65	48.6	2.18	4.05	59.8	1.77	4.98
x97	68.1	1.42	5.68	79.2	1.22	6.60	48.3	2.01	4.03	59.4	1.63	4.95
x86	67.8	1.27	5.65	78.9	1.09	6.58	47.9	1.80	3.99	59.0	1.46	4.92
x76	67.3	1.13	5.61	78.3	0.971	6.53	47.4	1.60	3.95	58.4	1.30	4.87
W18x71	58.0	1.22	4.83	65.6	1.08	5.47	44.6	1.59	3.72	52.3	1.36	4.36
x65	57.6	1.13	4.80	65.2	0.997	5.43	44.4	1.46	3.70	52.0	1.25	4.33
x60	57.5	1.04	4.79	65.0	0.923	5.42	44.0	1.36	3.67	51.5	1.17	4.29
x55	57.1	0.963	4.76	64.7	0.850	5.39	43.7	1.26	3.64	51.3	1.07	4.28
x50	56.8	0.880	4.73	64.3	0.778	5.36	43.5	1.15	3.63	51.0	0.980	4.25
W18x46	52.4	0.878	4.37	58.5	0.786	4.88	42.3	1.09	3.53	48.3	0.952	4.03
x40	52.1	0.768	4.34	58.1	0.688	4.84	41.8	0.957	3.48	47.8	0.837	3.98
x35	52.1	0.672	4.34	58.1	0.602	4.84	41.4	0.845	3.45	47.4	0.738	3.95

Case A: Shape perimeter, minus one flange surface.

Case C: Box perimeter, minus one flange surface.

Case B: Shape perimeter.

Case D: Box perimeter.



**Table 5a (Continued)**

Surface and Box Perimeters, Surface Areas and Weight-to-Perimeter Ratios for W-Shapes

Shape	Case A (See Fig. 1, Pg. 88)			Case B (See Fig. 1, Pg. 88)			Case C (See Fig. 1, Pg. 88)			Case D (See Fig. 1, Pg. 88)		
	Peri- meter	W/D Ratio	Surf. Area	Peri- meter	W/D Ratio	Surf. Area	Peri- meter	W/D Ratio	Surf. Area	Peri- meter	W/D Ratio	Surf. Area
	in.		ft <sup>2</sup> /ft	in.		ft <sup>2</sup> /ft	in.		ft <sup>2</sup> /ft	in.		ft <sup>2</sup> /ft
W16x100	62.7	1.59	5.23	73.1	1.37	6.09	44.4	2.25	3.70	54.8	1.82	4.57
x89	62.4	1.43	5.20	72.8	1.22	6.07	44.0	2.02	3.67	54.4	1.64	4.53
x77	61.6	1.25	5.13	71.9	1.07	5.99	43.3	1.78	3.61	53.6	1.44	4.47
x67	61.4	1.09	5.12	71.6	0.936	5.97	42.8	1.57	3.57	53.0	1.26	4.42
W16x57	52.1	1.09	4.34	59.2	0.963	4.93	39.9	1.43	3.33	47.0	1.21	3.92
x50	52.0	0.962	4.33	59.1	0.846	4.93	39.7	1.26	3.31	46.7	1.07	3.89
x45	51.7	0.870	4.31	58.7	0.767	4.89	39.2	1.15	3.27	46.3	0.972	3.86
x40	51.3	0.780	4.28	58.3	0.686	4.86	39.0	1.03	3.25	46.0	0.870	3.83
x36	51.3	0.702	4.28	58.3	0.617	4.86	38.8	0.928	3.23	45.8	0.786	3.82
W16x31	46.9	0.661	3.91	52.4	0.592	4.37	37.3	0.831	3.11	42.9	0.723	3.58
x26	46.6	0.558	3.88	52.1	0.499	4.34	36.9	0.705	3.08	42.4	0.613	3.53
W14x808	92.3	8.75	7.69	111	7.28	9.25	64.2	12.6	5.35	82.8	9.76	6.90
x730	90.4	8.08	7.53	108	6.76	9.00	62.7	11.6	5.23	80.6	9.06	6.72
x665	88.8	7.49	7.40	107	6.21	8.92	60.9	10.9	5.08	78.6	8.46	6.55
x605	86.9	6.96	7.24	104	5.82	8.67	59.2	10.2	4.93	76.6	7.90	6.38
x550	85.6	6.43	7.13	103	5.34	8.58	57.6	9.55	4.80	74.8	7.35	6.23
x500	84.0	5.95	7.00	101	4.95	8.42	56.2	8.90	4.68	73.2	6.83	6.10
x455	82.3	5.53	6.86	99.1	4.59	8.26	54.8	8.30	4.57	71.6	6.35	5.97
x426	81.8	5.21	6.82	98.5	4.32	8.21	54.1	7.87	4.51	70.8	6.02	5.90
x398	80.7	4.93	6.73	97.3	4.09	8.11	53.2	7.48	4.43	69.8	5.70	5.82
x370	79.9	4.63	6.66	96.4	3.84	8.03	52.3	7.07	4.36	68.8	5.38	5.73
x342	79.1	4.32	6.59	95.5	3.58	7.96	51.4	6.65	4.28	67.8	5.04	5.65
x311	78.1	3.98	6.51	94.3	3.30	7.86	50.4	6.17	4.20	66.6	4.67	5.55
x283	77.3	3.66	6.44	93.4	3.03	7.78	49.5	5.72	4.13	65.6	4.31	5.47
x257	76.5	3.36	6.38	92.5	2.78	7.71	48.8	5.27	4.07	64.8	3.97	5.40
x233	75.6	3.08	6.30	91.5	2.55	7.63	47.9	4.86	3.99	63.8	3.65	5.32
x211	75.2	2.81	6.27	91.0	2.32	7.58	47.2	4.47	3.93	63.0	3.35	5.25
x193	74.3	2.60	6.19	90.0	2.14	7.50	46.7	4.13	3.89	62.4	3.09	5.20
x176	74.1	2.38	6.18	89.8	1.96	7.48	46.1	3.82	3.84	61.8	2.85	5.15
x159	73.5	2.16	6.13	89.1	1.78	7.43	45.6	3.49	3.80	61.2	2.60	5.10
x145	72.7	1.99	6.06	88.2	1.64	7.35	45.1	3.22	3.76	60.6	2.39	5.05
W14x132	70.0	1.89	5.83	84.7	1.56	7.06	44.1	2.99	3.68	58.8	2.24	4.90
x120	70.1	1.71	5.84	84.8	1.42	7.07	43.7	2.75	3.64	58.4	2.05	4.87
x109	69.6	1.57	5.80	84.2	1.29	7.02	43.2	2.52	3.60	57.8	1.89	4.82
x99	69.2	1.43	5.77	83.8	1.18	6.98	43.0	2.30	3.58	57.6	1.72	4.80
x90	68.7	1.31	5.73	83.2	1.08	6.93	42.5	2.12	3.54	57.0	1.58	4.75

Case A: Shape perimeter, minus one flange surface.

Case C: Box perimeter, minus one flange surface.

Case B: Shape perimeter.

Case D: Box perimeter.



**Table 5a (Continued)**

Surface and Box Perimeters, Surface Areas and Weight-to-Perimeter Ratios for W-Shapes

Shape	Case A (See Fig. 1, Pg. 88)			Case B (See Fig. 1, Pg. 88)			Case C (See Fig. 1, Pg. 88)			Case D (See Fig. 1, Pg. 88)		
	Peri- meter	W/D Ratio	Surf. Area	Peri- meter	W/D Ratio	Surf. Area	Peri- meter	W/D Ratio	Surf. Area	Peri- meter	W/D Ratio	Surf. Area
	in.		ft <sup>2</sup> /ft	in.		ft <sup>2</sup> /ft	in.		ft <sup>2</sup> /ft	in.		ft <sup>2</sup> /ft
W14x82	56.5	1.45	4.71	66.6	1.23	5.55	38.7	2.12	3.23	48.8	1.68	4.07
x74	56.2	1.32	4.68	66.3	1.12	5.53	38.5	1.92	3.21	48.6	1.52	4.05
x68	55.7	1.22	4.64	65.7	1.04	5.48	38.0	1.79	3.17	48.0	1.42	4.00
x61	55.7	1.10	4.64	65.7	0.928	5.48	37.8	1.61	3.15	47.8	1.28	3.98
W14x53	49.8	1.06	4.15	57.9	0.915	4.83	35.9	1.48	2.99	43.9	1.21	3.66
x48	49.5	0.970	4.13	57.5	0.835	4.79	35.6	1.35	2.97	43.7	1.10	3.64
x43	49.2	0.874	4.10	57.2	0.752	4.77	35.4	1.21	2.95	43.4	0.991	3.62
W14x38	47.0	0.809	3.92	53.8	0.706	4.48	35.0	1.09	2.92	41.7	0.911	3.48
x34	46.9	0.725	3.91	53.7	0.633	4.48	34.8	0.977	2.90	41.5	0.819	3.46
x30	46.6	0.644	3.88	53.4	0.562	4.45	34.3	0.875	2.86	41.1	0.730	3.43
W14x26	41.4	0.628	3.45	46.5	0.559	3.88	32.8	0.793	2.73	37.9	0.686	3.16
x22	41.2	0.534	3.43	46.2	0.476	3.85	32.4	0.679	2.70	37.4	0.588	3.12
W12x336	69.3	4.85	5.78	82.7	4.06	6.89	47.0	7.15	3.92	60.4	5.56	5.03
x305	67.9	4.49	5.66	81.1	3.76	6.76	45.8	6.66	3.82	59.0	5.17	4.92
x279	66.6	4.19	5.55	79.7	3.50	6.64	44.9	6.21	3.74	58.0	4.81	4.83
x252	65.7	3.84	5.48	78.7	3.20	6.56	43.8	5.75	3.65	56.8	4.44	4.73
x230	64.7	3.55	5.39	77.6	2.96	6.47	43.1	5.34	3.59	56.0	4.11	4.67
x210	64.2	3.27	5.35	77.0	2.73	6.42	42.2	4.98	3.52	55.0	3.82	4.58
x190	63.4	3.00	5.28	76.1	2.50	6.34	41.5	4.58	3.46	54.2	3.51	4.52
x170	62.6	2.72	5.22	75.2	2.26	6.27	40.6	4.19	3.38	53.2	3.20	4.43
x152	62.1	2.45	5.18	74.6	2.04	6.22	39.9	3.81	3.33	52.4	2.90	4.37
x136	60.9	2.23	5.08	73.3	1.86	6.11	39.2	3.47	3.27	51.6	2.64	4.30
x120	60.4	1.99	5.03	72.7	1.65	6.06	38.5	3.12	3.21	50.8	2.36	4.23
x106	59.9	1.77	4.99	72.1	1.47	6.01	38.0	2.79	3.17	50.2	2.11	4.18
x96	59.7	1.61	4.98	71.9	1.34	5.99	37.6	2.55	3.13	49.8	1.93	4.15
x87	59.1	1.47	4.93	71.2	1.22	5.93	37.1	2.35	3.09	49.2	1.77	4.10
x79	58.8	1.34	4.90	70.9	1.11	5.91	36.9	2.14	3.08	49.0	1.61	4.08
x72	58.3	1.23	4.86	70.3	1.02	5.86	36.6	1.97	3.05	48.6	1.48	4.05
x65	58.3	1.11	4.86	70.3	0.925	5.86	36.2	1.80	3.02	48.2	1.35	4.02
W12x58	52.7	1.10	4.39	62.7	0.925	5.23	34.4	1.69	2.87	44.4	1.31	3.70
x53	52.0	1.02	4.33	62.0	0.855	5.17	34.2	1.55	2.85	44.2	1.20	3.68
W12x50	47.0	1.06	3.92	55.0	0.909	4.58	32.5	1.54	2.71	40.6	1.23	3.38
x45	46.2	0.974	3.85	54.3	0.829	4.53	32.3	1.39	2.69	40.3	1.12	3.36
x40	46.5	0.860	3.88	54.5	0.734	4.54	31.8	1.26	2.65	39.8	1.01	3.32
W12x35	43.2	0.810	3.60	49.8	0.703	4.15	31.6	1.11	2.63	38.1	0.919	3.18
x30	42.9	0.699	3.58	49.4	0.607	4.12	31.1	0.965	2.59	37.6	0.798	3.13
x26	42.5	0.612	3.54	49.0	0.531	4.08	30.9	0.841	2.58	37.4	0.695	3.12

Case A: Shape perimeter, minus one flange surface.

Case C: Box perimeter, minus one flange surface.

Case B: Shape perimeter.

Case D: Box perimeter.



**Table 5a (Continued)**

Surface and Box Perimeters, Surface Areas and Weight-to-Perimeter Ratios for W-Shapes

Shape	Case A (See Fig. 1, Pg. 88)			Case B (See Fig. 1, Pg. 88)			Case C (See Fig. 1, Pg. 88)			Case D (See Fig. 1, Pg. 88)		
	Peri- meter	W/D Ratio	Surf. Area	Peri- meter	W/D Ratio	Surf. Area	Peri- meter	W/D Ratio	Surf. Area	Peri- meter	W/D Ratio	Surf. Area
	in.		ft <sup>2</sup> /ft	in.		ft <sup>2</sup> /ft	in.		ft <sup>2</sup> /ft	in.		ft <sup>2</sup> /ft
W12x22	35.3	0.623	2.94	39.3	0.560	3.28	28.6	0.769	2.38	32.7	0.673	2.73
x19	35.2	0.540	2.93	39.2	0.485	3.27	28.4	0.669	2.37	32.4	0.586	2.70
x16	35.0	0.457	2.92	39.0	0.410	3.25	28.0	0.571	2.33	32.0	0.500	2.67
x14	34.6	0.405	2.88	38.6	0.363	3.22	27.8	0.504	2.32	31.7	0.442	2.64
W10x112	51.5	2.17	4.29	61.9	1.81	5.16	33.2	3.37	2.77	43.6	2.57	3.63
x100	50.7	1.97	4.23	61.0	1.64	5.08	32.5	3.08	2.71	42.8	2.34	3.57
x88	50.5	1.74	4.21	60.8	1.45	5.07	31.9	2.76	2.66	42.2	2.09	3.52
x77	49.9	1.54	4.16	60.1	1.28	5.01	31.4	2.45	2.62	41.6	1.85	3.47
x68	49.1	1.38	4.09	59.2	1.15	4.93	30.9	2.20	2.58	41.0	1.66	3.42
x60	49.1	1.22	4.09	59.2	1.01	4.93	30.5	1.97	2.54	40.6	1.48	3.38
x54	48.6	1.11	4.05	58.6	0.922	4.88	30.2	1.79	2.52	40.2	1.34	3.35
x49	48.3	1.01	4.03	58.3	0.840	4.86	30.0	1.63	2.50	40.0	1.23	3.33
W10x45	42.6	1.06	3.55	50.7	0.888	4.23	28.2	1.60	2.35	36.2	1.24	3.02
x39	42.0	0.929	3.50	50.0	0.780	4.17	27.8	1.40	2.32	35.8	1.09	2.98
x33	42.0	0.786	3.50	49.9	0.661	4.16	27.4	1.20	2.28	35.4	0.932	2.95
W10x30	37.1	0.809	3.09	42.9	0.699	3.58	26.8	1.12	2.23	32.6	0.920	2.72
x26	36.7	0.708	3.06	42.5	0.612	3.54	26.4	0.985	2.20	32.1	0.810	2.68
x22	36.3	0.606	3.03	42.1	0.523	3.51	26.2	0.840	2.18	31.9	0.690	2.66
W10x19	31.3	0.607	2.61	35.3	0.538	2.94	24.4	0.779	2.03	28.4	0.669	2.37
x17	31.3	0.543	2.61	35.3	0.482	2.94	24.2	0.702	2.02	28.2	0.603	2.35
x15	31.0	0.484	2.58	35.0	0.429	2.92	24.0	0.625	2.00	28.0	0.536	2.33
x12	30.6	0.392	2.55	34.6	0.347	2.88	23.7	0.506	1.98	27.7	0.433	2.31
W8x67	40.7	1.65	3.39	48.9	1.37	4.08	26.3	2.55	2.19	34.6	1.94	2.88
x58	40.2	1.44	3.35	48.5	1.20	4.04	25.7	2.26	2.14	33.9	1.71	2.83
x48	39.7	1.21	3.31	47.8	1.00	3.98	25.1	1.91	2.09	33.2	1.45	2.77
x40	39.0	1.03	3.25	47.1	0.849	3.93	24.6	1.63	2.05	32.6	1.23	2.72
x35	38.6	0.907	3.22	46.7	0.749	3.89	24.3	1.44	2.03	32.3	1.08	2.69
x31	38.6	0.803	3.22	46.6	0.665	3.88	24.0	1.29	2.00	32.0	0.969	2.67
W8x28	34.2	0.819	2.85	40.7	0.688	3.39	22.7	1.23	1.89	29.2	0.959	2.43
x24	34.1	0.704	2.84	40.6	0.591	3.38	22.4	1.07	1.87	28.9	0.830	2.41
W8x21	31.1	0.675	2.59	36.4	0.577	3.03	21.8	0.963	1.82	27.1	0.775	2.26
x18	30.9	0.583	2.58	36.1	0.499	3.01	21.5	0.837	1.79	26.8	0.672	2.23
W8x15	27.2	0.551	2.27	31.2	0.481	2.60	20.2	0.743	1.68	24.2	0.620	2.02
x13	26.9	0.483	2.24	30.9	0.421	2.58	20.0	0.650	1.67	24.0	0.542	2.00
x10	26.7	0.375	2.23	30.6	0.327	2.55	19.7	0.508	1.64	23.7	0.422	1.98

Case A: Shape perimeter, minus one flange surface.

Case C: Box perimeter, minus one flange surface.

Case B: Shape perimeter.

Case D: Box perimeter.

**Table 5a (Continued)**

Surface and Box Perimeters, Surface Areas and Weight-to-Perimeter Ratios for W-Shapes

Shape	Case A (See Fig. 1, Pg. 88)			Case B (See Fig. 1, Pg. 88)			Case C (See Fig. 1, Pg. 88)			Case D (See Fig. 1, Pg. 88)		
	Peri- meter	W/D Ratio	Surf. Area	Peri- meter	W/D Ratio	Surf. Area	Peri- meter	W/D Ratio	Surf. Area	Peri- meter	W/D Ratio	Surf. Area
	in.		ft <sup>2</sup> /ft	in.		ft <sup>2</sup> /ft	in.		ft <sup>2</sup> /ft	in.		ft <sup>2</sup> /ft
W6x25	29.8	0.839	2.48	35.9	0.696	2.99	18.8	1.33	1.57	24.9	1.00	2.08
x20	29.5	0.678	2.46	35.5	0.563	2.96	18.4	1.09	1.53	24.4	0.820	2.03
x15	28.8	0.521	2.40	34.8	0.431	2.90	18.0	0.833	1.50	24.0	0.625	2.00
W6x16	23.4	0.684	1.95	27.4	0.584	2.28	16.6	0.964	1.38	20.6	0.777	1.72
x12	22.8	0.526	1.90	26.8	0.448	2.23	16.1	0.745	1.34	20.1	0.597	1.68
x9	22.6	0.398	1.88	26.6	0.338	2.22	15.7	0.573	1.31	19.7	0.457	1.64
x8.5	22.7	0.374	1.89	26.6	0.320	2.22	15.6	0.545	1.30	19.5	0.436	1.63
W5x19	24.5	0.776	2.04	29.5	0.644	2.46	15.3	1.24	1.28	20.4	0.931	1.70
x16	24.1	0.664	2.01	29.1	0.550	2.43	15.0	1.07	1.25	20.0	0.800	1.67
W4x13	19.4	0.670	1.62	23.4	0.556	1.95	12.4	1.05	1.03	16.4	0.793	1.37
Case A: Shape perimeter, minus one flange surface.						Case C: Box perimeter, minus one flange surface.						
Case B: Shape perimeter.						Case D: Box perimeter.						



**Table 5b**

Surface and Box Perimeters, Surface Areas and Weight-to-Perimeter Ratios for M-Shapes

Shape	Case A (See Fig. 1, Pg. 88)			Case B (See Fig. 1, Pg. 88)			Case C (See Fig. 1, Pg. 88)			Case D (See Fig. 1, Pg. 88)		
	Peri- meter	W/D Ratio	Surf. Area	Peri- meter	W/D Ratio	Surf. Area	Peri- meter	W/D Ratio	Surf. Area	Peri- meter	W/D Ratio	Surf. Area
	in.		ft <sup>2</sup> /ft	in.		ft <sup>2</sup> /ft	in.		ft <sup>2</sup> /ft	in.		ft <sup>2</sup> /ft
M12x11.8	32.5	0.363	2.71	35.6	0.331	2.97	27.1	0.435	2.26	30.1	0.392	2.51
x10.8	32.5	0.332	2.71	35.6	0.303	2.97	27.1	0.399	2.26	30.1	0.359	2.51
x10	33.0	0.303	2.75	36.2	0.276	3.02	27.3	0.366	2.28	30.5	0.328	2.54
M10x9	27.4	0.328	2.28	30.1	0.299	2.51	22.7	0.396	1.89	25.4	0.354	2.12
x8	27.4	0.292	2.28	30.1	0.266	2.51	22.6	0.354	1.88	25.3	0.316	2.11
x7.5	27.4	0.274	2.28	30.1	0.249	2.51	22.7	0.330	1.89	25.4	0.295	2.12
M8x6.5	22.2	0.293	1.85	24.5	0.265	2.04	18.3	0.355	1.53	20.6	0.316	1.72
x6.2	22.4	0.277	1.87	24.7	0.251	2.06	18.3	0.339	1.53	20.6	0.301	1.72
M6x4.4	17.0	0.259	1.42	18.8	0.234	1.57	13.8	0.319	1.15	15.7	0.280	1.31
x3.7	17.2	0.215	1.43	19.2	0.193	1.60	13.8	0.268	1.15	15.8	0.234	1.32
M5x18.9*	23.9	0.791	1.99	28.9	0.654	2.41	15.0	1.26	1.25	20.0	0.945	1.67
M4x6	18.2	0.330	1.52	22.0	0.273	1.83	11.4	0.526	0.950	15.2	0.395	1.27
Case A: Shape perimeter, minus one flange surface.						Case C: Box perimeter, minus one flange surface.						
Case B: Shape perimeter.						Case D: Box perimeter.						





**Table 5c**

Surface and Box Perimeters, Surface Areas and Weight-to-Perimeter Ratios for S-Shapes

Shape	Case A (See Fig. 1, Pg. 88)			Case B (See Fig. 1, Pg. 88)			Case C (See Fig. 1, Pg. 88)			Case D (See Fig. 1, Pg. 88)		
	Peri- meter	W/D Ratio	Surf. Area	Peri- meter	W/D Ratio	Surf. Area	Peri- meter	W/D Ratio	Surf. Area	Peri- meter	W/D Ratio	Surf. Area
	in.		ft <sup>2</sup> /ft	in.		ft <sup>2</sup> /ft	in.		ft <sup>2</sup> /ft	in.		ft <sup>2</sup> /ft
S24x121	68.6	1.76	5.72	76.6	1.58	6.38	57.1	2.12	4.76	65.1	1.86	5.43
x106	68.4	1.55	5.70	76.3	1.39	6.36	56.9	1.86	4.74	64.7	1.64	5.39
S24x100	65.5	1.53	5.46	72.8	1.37	6.07	55.3	1.81	4.61	62.5	1.60	5.21
x90	65.4	1.38	5.45	72.5	1.24	6.04	55.1	1.63	4.59	62.3	1.44	5.19
x80	65.2	1.23	5.43	72.2	1.11	6.02	55.0	1.45	4.58	62.0	1.29	5.17
S20x96	57.9	1.66	4.83	65.1	1.47	5.43	47.8	2.01	3.98	55.0	1.75	4.58
x86	57.8	1.49	4.82	64.9	1.33	5.41	47.7	1.80	3.98	54.7	1.57	4.56
S20x75	55.4	1.35	4.62	61.8	1.21	5.15	46.4	1.62	3.87	52.8	1.42	4.40
x66	55.3	1.19	4.61	61.5	1.07	5.13	46.3	1.43	3.86	52.5	1.26	4.38
S18x70	50.9	1.38	4.24	57.2	1.22	4.77	42.3	1.65	3.53	48.5	1.44	4.04
x54.7	50.7	1.08	4.23	56.7	0.965	4.73	42.0	1.30	3.50	48.0	1.14	4.00
S15x50	43.6	1.15	3.63	49.2	1.02	4.10	35.6	1.40	2.97	41.3	1.21	3.44
x42.9	43.4	0.988	3.62	48.9	0.877	4.08	35.5	1.21	2.96	41.0	1.05	3.42
S12x50	36.9	1.36	3.08	42.4	1.18	3.53	29.5	1.69	2.46	35.0	1.43	2.92
x40.8	36.6	1.11	3.05	41.9	0.974	3.49	29.3	1.39	2.44	34.5	1.18	2.88
S12x35	36.4	0.962	3.03	41.5	0.843	3.46	29.1	1.20	2.43	34.2	1.02	2.85
x31.8	36.3	0.876	3.03	41.3	0.770	3.44	29.0	1.10	2.42	34.0	0.935	2.83
S10x35	31.7	1.10	2.64	36.7	0.954	3.06	24.9	1.41	2.08	29.9	1.17	2.49
x25.4	31.5	0.806	2.63	36.1	0.704	3.01	24.7	1.03	2.06	29.3	0.867	2.44
S8x23	26.0	0.885	2.17	30.1	0.764	2.51	20.2	1.14	1.68	24.3	0.947	2.03
x18.4	25.8	0.713	2.15	29.8	0.617	2.48	20.0	0.920	1.67	24.0	0.767	2.00
S6x17.25	20.4	0.846	1.70	24.0	0.719	2.00	15.6	1.11	1.30	19.1	0.903	1.59
x12.5	20.2	0.619	1.68	23.5	0.532	1.96	15.3	0.817	1.28	18.7	0.668	1.56
S5x10	17.3	0.578	1.44	20.3	0.493	1.69	13.0	0.769	1.08	16.0	0.625	1.33
S4x9.5	14.5	0.655	1.21	17.3	0.549	1.44	10.8	0.880	0.900	13.6	0.699	1.13
x7.7	14.4	0.535	1.20	17.1	0.450	1.43	10.7	0.720	0.892	13.3	0.579	1.11
S3x7.5	11.8	0.636	0.983	14.3	0.524	1.19	8.51	0.881	0.709	11.0	0.682	0.917
x5.7	11.6	0.491	0.967	14.0	0.407	1.17	8.33	0.684	0.694	10.7	0.533	0.892

Case A: Shape perimeter, minus one flange surface.

Case C: Box perimeter, minus one flange surface.

Case B: Shape perimeter.

Case D: Box perimeter.



**Table 5d**

Surface and Box Perimeters, Surface Areas and Weight-to-Perimeter Ratios for HP-Shapes

Shape	Case A (See Fig. 1, Pg. 88)			Case B (See Fig. 1, Pg. 88)			Case C (See Fig. 1, Pg. 88)			Case D (See Fig. 1, Pg. 88)		
	Peri- meter	W/D Ratio	Surf. Area	Peri- meter	W/D Ratio	Surf. Area	Peri- meter	W/D Ratio	Surf. Area	Peri- meter	W/D Ratio	Surf. Area
	in.		ft <sup>2</sup> /ft	in.		ft <sup>2</sup> /ft	in.		ft <sup>2</sup> /ft	in.		ft <sup>2</sup> /ft
HP14x117	70.5	1.66	5.88	85.4	1.37	7.12	43.3	2.70	3.61	58.2	2.01	4.85
x102	69.9	1.46	5.83	84.7	1.20	7.06	42.8	2.38	3.57	57.6	1.77	4.80
x89	69.7	1.28	5.81	84.4	1.05	7.03	42.3	2.10	3.53	57.0	1.56	4.75
x73	69.1	1.06	5.76	83.7	0.872	6.98	41.8	1.75	3.48	56.4	1.29	4.70
HP12x84	59.0	1.42	4.92	71.3	1.18	5.94	36.9	2.28	3.08	49.2	1.71	4.10
x74	58.7	1.26	4.89	70.9	1.04	5.91	36.4	2.03	3.03	48.6	1.52	4.05
x63	58.5	1.08	4.88	70.6	0.892	5.88	35.9	1.75	2.99	48.0	1.31	4.00
x53	57.6	0.920	4.80	69.6	0.761	5.80	35.6	1.49	2.97	47.6	1.11	3.97
HP10x57	48.4	1.18	4.03	58.6	0.973	4.88	30.2	1.89	2.52	40.4	1.41	3.37
x42	48.2	0.871	4.02	58.3	0.720	4.86	29.5	1.42	2.46	39.6	1.06	3.30
HP8x36	38.5	0.935	3.21	46.7	0.771	3.89	24.2	1.49	2.02	32.3	1.11	2.69
Case A: Shape perimeter, minus one flange surface.						Case C: Box perimeter, minus one flange surface.						
Case B: Shape perimeter.						Case D: Box perimeter.						



**Table 5e**

Surface and Box Perimeters, Surface Areas and Weight-to-Perimeter Ratios for C-Shapes (American Standard Channels)

Shape	Case A (See Fig. 1, Pg. 88)			Case B (See Fig. 1, Pg. 88)			Case C (See Fig. 1, Pg. 88)			Case D (See Fig. 1, Pg. 88)		
	Peri- meter	W/D Ratio	Surf. Area	Peri- meter	W/D Ratio	Surf. Area	Peri- meter	W/D Ratio	Surf. Area	Peri- meter	W/D Ratio	Surf. Area
	in.		ft <sup>2</sup> /ft	in.		ft <sup>2</sup> /ft	in.		ft <sup>2</sup> /ft	in.		ft <sup>2</sup> /ft
C15x50	39.7	1.26	3.31	43.4	1.15	3.62	33.7	1.48	2.81	37.4	1.34	3.12
x40	39.2	1.02	3.27	42.7	0.937	3.56	33.5	1.19	2.79	37.0	1.08	3.08
x33.9	38.8	0.874	3.23	42.2	0.803	3.52	33.4	1.01	2.78	36.8	0.921	3.07
C12x30	32.3	0.929	2.69	35.5	0.845	2.96	27.2	1.10	2.27	30.3	0.990	2.53
x25	32.0	0.781	2.67	35.0	0.714	2.92	27.1	0.923	2.26	30.1	0.831	2.51
x20.7	31.7	0.653	2.64	34.6	0.598	2.88	26.9	0.770	2.24	29.9	0.692	2.49
C10x30	28.0	1.07	2.33	31.0	0.968	2.58	23.0	1.30	1.92	26.1	1.15	2.18
x25	27.6	0.906	2.30	30.5	0.820	2.54	22.9	1.09	1.91	25.8	0.969	2.15
x20	27.2	0.735	2.27	29.9	0.669	2.49	22.7	0.881	1.89	25.5	0.784	2.13
x15.3	26.8	0.571	2.23	29.4	0.520	2.45	22.6	0.677	1.88	25.2	0.607	2.10
C9x20	24.9	0.803	2.08	27.6	0.725	2.30	20.7	0.966	1.73	23.3	0.858	1.94
x15	24.5	0.612	2.04	27.0	0.556	2.25	20.5	0.732	1.71	23.0	0.652	1.92
x13.4	24.3	0.551	2.03	26.7	0.502	2.23	20.4	0.657	1.70	22.9	0.585	1.91
C8x18.75	22.6	0.830	1.88	25.1	0.747	2.09	18.5	1.01	1.54	21.1	0.889	1.76
x13.75	22.1	0.622	1.84	24.4	0.564	2.03	18.3	0.751	1.53	20.7	0.664	1.73
x11.5	21.9	0.525	1.83	24.1	0.477	2.01	18.3	0.628	1.53	20.5	0.561	1.71
C7x14.75	20.0	0.738	1.67	22.3	0.661	1.86	16.3	0.905	1.36	18.6	0.793	1.55
x12.25	19.7	0.622	1.64	21.9	0.559	1.83	16.2	0.756	1.35	18.4	0.666	1.53
x9.8	19.4	0.505	1.62	21.5	0.456	1.79	16.1	0.609	1.34	18.2	0.538	1.52
C6x13	17.6	0.739	1.47	19.8	0.657	1.65	14.2	0.915	1.18	16.3	0.798	1.36
x10.5	17.3	0.607	1.44	19.3	0.544	1.61	14.0	0.750	1.17	16.1	0.652	1.34
x8.2	17.0	0.482	1.42	18.9	0.434	1.58	13.9	0.590	1.16	15.8	0.519	1.32
C5x9	14.9	0.604	1.24	16.8	0.536	1.40	11.9	0.756	0.992	13.8	0.652	1.15
x6.7	14.5	0.462	1.21	16.3	0.411	1.36	11.8	0.568	0.983	13.5	0.496	1.13
C4x7.25	12.4	0.585	1.03	14.2	0.511	1.18	9.72	0.746	0.810	11.4	0.636	0.950
x5.4	12.1	0.446	1.01	13.6	0.397	1.13	9.58	0.564	0.798	11.2	0.482	0.933
x4.5	12.1	0.372	1.01	13.6	0.331	1.13	9.58	0.470	0.798	11.2	0.402	0.933
C3x6	10.1	0.594	0.842	11.7	0.513	0.975	7.60	0.789	0.633	9.20	0.652	0.767
x5	9.86	0.507	0.822	11.4	0.439	0.950	7.50	0.667	0.625	9.00	0.556	0.750
x4.1	9.61	0.427	0.801	11.0	0.373	0.917	7.41	0.553	0.618	8.82	0.465	0.735
x3.5	9.50	0.368	0.792	10.9	0.321	0.908	7.37	0.475	0.614	8.74	0.400	0.728

Case A: Shape perimeter, minus one flange surface.  
Case B: Shape perimeter.

Case C: Box perimeter, minus one flange surface.  
Case D: Box perimeter.



**Table 5f**

Surface and Box Perimeters, Surface Areas and Weight-to-Perimeter Ratios for MC-Shapes

Shape	Case A (See Fig. 1, Pg. 88)			Case B (See Fig. 1, Pg. 88)			Case C (See Fig. 1, Pg. 88)			Case D (See Fig. 1, Pg. 88)		
	Peri- meter	W/D Ratio	Surf. Area	Peri- meter	W/D Ratio	Surf. Area	Peri- meter	W/D Ratio	Surf. Area	Peri- meter	W/D Ratio	Surf. Area
	in.		ft <sup>2</sup> /ft	in.		ft <sup>2</sup> /ft	in.		ft <sup>2</sup> /ft	in.		ft <sup>2</sup> /ft
MC18x58	47.0	1.23	3.92	51.2	1.13	4.27	40.2	1.44	3.35	44.4	1.31	3.70
x51.9	46.7	1.11	3.89	50.8	1.02	4.23	40.1	1.29	3.34	44.2	1.17	3.68
x45.8	46.5	0.985	3.88	50.5	0.907	4.21	40.0	1.15	3.33	44.0	1.04	3.67
x42.7	46.3	0.922	3.86	50.3	0.849	4.19	40.0	1.07	3.33	43.9	0.973	3.66
MC13x50	37.6	1.33	3.13	42.0	1.19	3.50	30.4	1.64	2.53	34.8	1.44	2.90
x40	37.0	1.08	3.08	41.1	0.973	3.43	30.2	1.32	2.52	34.4	1.16	2.87
x35	36.7	0.954	3.06	40.7	0.860	3.39	30.1	1.16	2.51	34.1	1.03	2.84
x31.8	36.5	0.871	3.04	40.5	0.785	3.38	30.0	1.06	2.50	34.0	0.935	2.83
MC12x50	35.0	1.43	2.92	39.1	1.28	3.26	28.1	1.78	2.34	32.3	1.55	2.69
x45	34.6	1.30	2.88	38.6	1.17	3.22	28.0	1.61	2.33	32.0	1.41	2.67
x40	34.3	1.17	2.86	38.2	1.05	3.18	27.9	1.43	2.33	31.8	1.26	2.65
x35	34.0	1.03	2.83	37.7	0.928	3.14	27.8	1.26	2.32	31.5	1.11	2.63
x31	33.7	0.920	2.81	37.4	0.829	3.12	27.7	1.12	2.31	31.3	0.990	2.61
MC12x10.6	27.8	0.381	2.32	29.3	0.362	2.44	25.5	0.416	2.13	27.0	0.393	2.25
MC10x41.1	31.4	1.31	2.62	35.7	1.15	2.98	24.3	1.69	2.03	28.6	1.44	2.38
x33.6	30.8	1.09	2.57	34.9	0.963	2.91	24.1	1.39	2.01	28.2	1.19	2.35
x28.5	30.4	0.938	2.53	34.3	0.831	2.86	24.0	1.19	2.00	27.9	1.02	2.33
MC10x25	28.9	0.865	2.41	32.3	0.774	2.69	23.4	1.07	1.95	26.8	0.933	2.23
x22	28.7	0.767	2.39	32.0	0.688	2.67	23.3	0.944	1.94	26.6	0.827	2.22
MC10x8.4	23.8	0.353	1.98	25.3	0.332	2.11	21.5	0.391	1.79	23.0	0.365	1.92
MC9x25.4	27.2	0.934	2.27	30.7	0.827	2.56	21.5	1.18	1.79	25.0	1.02	2.08
x23.9	27.0	0.885	2.25	30.5	0.784	2.54	21.5	1.11	1.79	24.9	0.960	2.08
MC8x22.8	25.2	0.905	2.10	28.7	0.794	2.39	19.5	1.17	1.63	23.0	0.991	1.92
x21.4	25.1	0.853	2.09	28.5	0.751	2.38	19.5	1.10	1.63	22.9	0.934	1.91
MC8x20	23.9	0.837	1.99	27.0	0.741	2.25	19.0	1.05	1.58	22.1	0.905	1.84
x18.7	23.8	0.786	1.98	26.8	0.698	2.23	19.0	0.984	1.58	22.0	0.850	1.83
MC8x8.5	20.8	0.409	1.73	22.7	0.374	1.89	17.9	0.475	1.49	19.7	0.431	1.64
MC7x22.7	23.5	0.966	1.96	27.1	0.838	2.26	17.6	1.29	1.47	21.2	1.07	1.77
x19.1	23.1	0.827	1.93	26.5	0.721	2.21	17.5	1.09	1.46	20.9	0.914	1.74
MC6x18	21.2	0.849	1.77	24.7	0.729	2.06	15.5	1.16	1.29	19.0	0.947	1.58
x15.3	21.3	0.718	1.78	24.8	0.617	2.07	15.5	0.987	1.29	19.0	0.805	1.58
MC6x16.3	19.9	0.819	1.66	22.9	0.712	1.91	15.0	1.09	1.25	18.0	0.906	1.50
x15.1	19.7	0.766	1.64	22.6	0.668	1.88	14.9	1.01	1.24	17.9	0.844	1.49
MC6x12	18.6	0.645	1.55	21.1	0.569	1.76	14.5	0.828	1.21	17.0	0.706	1.42

Case A: Shape perimeter, minus one flange surface.  
Case B: Shape perimeter.

Case C: Box perimeter, minus one flange surface.  
Case D: Box perimeter.



**Table 5g**

Surface and Box Perimeters, Surface Areas and Weight-to-Perimeter Ratios for Angles

Shape	Case A-1 (See Fig. 1, Pg. 89)			Case A-2 (See Fig. 1, Pg. 89)			Case B (See Fig. 1, Pg. 89)		
	Perimeter	W/D Ratio	Surf. Area	Perimeter	W/D Ratio	Surf. Area	Perimeter	W/D Ratio	Surf. Area
	in.		ft <sup>2</sup> /ft	in.		ft <sup>2</sup> /ft	in.		ft <sup>2</sup> /ft
L8x8x1-1/8	23.7	2.41	1.98	23.7	2.41	1.98	31.7	1.80	2.64
x1	23.7	2.16	1.98	23.7	2.16	1.98	31.7	1.62	2.64
x7/8	23.7	1.91	1.98	23.7	1.91	1.98	31.7	1.43	2.64
x3/4	23.7	1.65	1.98	23.7	1.65	1.98	31.7	1.24	2.64
x5/8	23.7	1.39	1.98	23.7	1.39	1.98	31.7	1.04	2.64
x9/16	23.7	1.26	1.98	23.7	1.26	1.98	31.7	0.94	2.64
x1/2	23.7	1.13	1.98	23.7	1.13	1.98	31.7	0.842	2.64
L8x6x1	21.8	2.04	1.82	19.8	2.24	1.65	27.8	1.60	2.32
x7/8	21.8	1.80	1.82	19.8	1.98	1.65	27.8	1.41	2.32
x3/4	21.8	1.56	1.82	19.8	1.72	1.65	27.8	1.22	2.32
x5/8	21.8	1.31	1.82	19.8	1.44	1.65	27.8	1.03	2.32
x9/16	21.8	1.19	1.82	19.8	1.31	1.65	27.8	0.932	2.32
x1/2	21.8	1.06	1.82	19.8	1.17	1.65	27.8	0.835	2.32
x7/16	21.8	0.936	1.82	19.8	1.03	1.65	27.8	0.734	2.32
L8x4x1	19.8	1.90	1.65	15.8	2.38	1.32	23.8	1.58	1.98
x7/8	19.8	1.68	1.65	15.8	2.11	1.32	23.8	1.40	1.98
x3/4	19.8	1.46	1.65	15.8	1.83	1.32	23.8	1.21	1.98
x5/8	19.8	1.23	1.65	15.8	1.54	1.32	23.8	1.03	1.98
x9/16	19.8	1.12	1.65	15.8	1.40	1.32	23.8	0.929	1.98
x1/2	19.8	0.995	1.65	15.8	1.25	1.32	23.8	0.828	1.98
x7/16	19.8	0.879	1.65	15.8	1.10	1.32	23.8	0.731	1.98
L7x4x3/4	17.8	1.47	1.48	14.8	1.77	1.23	21.8	1.20	1.82
x5/8	17.8	1.24	1.48	14.8	1.49	1.23	21.8	1.01	1.82
x1/2	17.8	1.01	1.48	14.8	1.21	1.23	21.8	0.821	1.82
x7/16	17.8	0.888	1.48	14.8	1.07	1.23	21.8	0.725	1.82
x3/8	17.8	0.764	1.48	14.8	0.919	1.23	21.8	0.624	1.82
L6x6x1	17.8	2.11	1.48	17.8	2.11	1.48	23.8	1.58	1.98
x7/8	17.8	1.87	1.48	17.8	1.87	1.48	23.8	1.39	1.98
x3/4	17.8	1.62	1.48	17.8	1.62	1.48	23.8	1.21	1.98
x5/8	17.8	1.37	1.48	17.8	1.37	1.48	23.8	1.02	1.98
x9/16	17.8	1.24	1.48	17.8	1.24	1.48	23.8	0.924	1.98
x1/2	17.8	1.10	1.48	17.8	1.10	1.48	23.8	0.824	1.98
x7/16	17.8	0.972	1.48	17.8	0.972	1.48	23.8	0.727	1.98
x3/8	17.8	0.837	1.48	17.8	0.837	1.48	23.8	0.626	1.98
x5/16	17.8	0.702	1.48	17.8	0.702	1.48	23.8	0.525	1.98

Case A-1: Shape perimeter, minus short leg surface.

Case B: Shape perimeter.

Case A-2: Shape perimeter, minus long leg surface.



**Table 5g (Continued)**

Surface and Box Perimeters, Surface Areas and Weight-to-Perimeter Ratios for Angles

Shape	Case A-1 (See Fig. 1, Pg. 89)			Case A-2 (See Fig. 1, Pg. 89)			Case B (See Fig. 1, Pg. 89)		
	Perimeter	W/D Ratio	Surf. Area	Perimeter	W/D Ratio	Surf. Area	Perimeter	W/D Ratio	Surf. Area
	in.		ft <sup>2</sup> /ft	in.		ft <sup>2</sup> /ft	in.		ft <sup>2</sup> /ft
L6x4x7/8	15.8	1.72	1.32	13.8	1.96	1.15	19.8	1.37	1.65
x3/4	15.8	1.49	1.32	13.8	1.70	1.15	19.8	1.19	1.65
x5/8	15.8	1.25	1.32	13.8	1.43	1.15	19.8	1.00	1.65
x9/16	15.8	1.13	1.32	13.8	1.30	1.15	19.8	0.904	1.65
x1/2	15.8	1.01	1.32	13.8	1.16	1.15	19.8	0.808	1.65
x7/16	15.8	0.892	1.32	13.8	1.02	1.15	19.8	0.712	1.65
x3/8	15.8	0.772	1.32	13.8	0.884	1.15	19.8	0.616	1.65
x5/16	15.8	0.646	1.32	13.8	0.739	1.15	19.8	0.515	1.65
L6x3-1/2x1/2	15.3	1.00	1.28	12.8	1.20	1.07	18.8	0.814	1.57
x3/8	15.3	0.758	1.28	12.8	0.906	1.07	18.8	0.617	1.57
x5/16	15.3	0.635	1.28	12.8	0.759	1.07	18.8	0.517	1.57
L5x5x7/8	14.8	1.84	1.23	14.8	1.84	1.23	19.8	1.38	1.65
x3/4	14.8	1.60	1.23	14.8	1.60	1.23	19.8	1.20	1.65
x5/8	14.8	1.36	1.23	14.8	1.36	1.23	19.8	1.02	1.65
x1/2	14.8	1.10	1.23	14.8	1.10	1.23	19.8	0.823	1.65
x7/16	14.8	0.973	1.23	14.8	0.973	1.23	19.8	0.727	1.65
x3/8	14.8	0.838	1.23	14.8	0.838	1.23	19.8	0.626	1.65
x5/16	14.8	0.703	1.23	14.8	0.703	1.23	19.8	0.525	1.65
L5x3-1/2x3/4	13.3	1.49	1.11	11.8	1.68	0.98	16.8	1.18	1.400
x5/8	13.3	1.26	1.11	11.8	1.42	0.98	16.8	1.00	1.400
x1/2	13.3	1.02	1.11	11.8	1.15	0.98	16.8	0.810	1.400
x3/8	13.3	0.782	1.11	11.8	0.881	0.98	16.8	0.619	1.400
x5/16	13.3	0.656	1.11	11.8	0.739	0.98	16.8	0.519	1.400
x1/4	13.3	0.529	1.11	11.8	0.596	0.98	16.8	0.418	1.400
L5x3x1/2	12.8	1.00	1.07	10.8	1.19	0.90	15.8	0.810	1.320
x7/16	12.8	0.883	1.07	10.8	1.05	0.90	15.8	0.715	1.320
x3/8	12.8	0.761	1.07	10.8	0.902	0.90	15.8	0.616	1.320
x5/16	12.8	0.640	1.07	10.8	0.758	0.90	15.8	0.518	1.320
x1/4	12.8	0.516	1.07	10.8	0.611	0.90	15.8	0.418	1.320
L4x4x3/4	11.8	1.57	0.98	11.8	1.57	0.983	15.8	1.17	1.320
x5/8	11.8	1.33	0.98	11.8	1.33	0.983	15.8	0.994	1.320
x1/2	11.8	1.08	0.98	11.8	1.08	0.983	15.8	0.804	1.320
x7/16	11.8	0.949	0.98	11.8	0.949	0.983	15.8	0.709	1.320
x3/8	11.8	0.824	0.98	11.8	0.824	0.983	15.8	0.615	1.320
x5/16	11.8	0.692	0.98	11.8	0.692	0.983	15.8	0.516	1.320
x1/4	11.8	0.558	0.98	11.8	0.558	0.983	15.8	0.416	1.320

Case A-1: Shape perimeter, minus short leg surface.

Case B: Shape perimeter.

Case A-2: Shape perimeter, minus long leg surface.



**Table 5g (Continued)**

Surface and Box Perimeters, Surface Areas and Weight-to-Perimeter Ratios for Angles

Shape	Case A-1 (See Fig. 1, Pg. 89)			Case A-2 (See Fig. 1, Pg. 89)			Case B (See Fig. 1, Pg. 89)		
	Perimeter	W/D Ratio	Surf. Area	Perimeter	W/D Ratio	Surf. Area	Perimeter	W/D Ratio	Surf. Area
	in.		ft <sup>2</sup> /ft	in.		ft <sup>2</sup> /ft	in.		ft <sup>2</sup> /ft
L4x3-1/2x1/2	11.5	1.03	0.96	11.0	1.08	0.917	15.0	0.793	1.250
x3/8	11.5	0.791	0.96	11.0	0.827	0.917	15.0	0.607	1.250
x5/16	11.5	0.665	0.96	11.0	0.695	0.917	15.0	0.510	1.250
x1/4	11.5	0.537	0.96	11.0	0.562	0.917	15.0	0.412	1.250
L4x3x5/8	11.0	1.24	0.92	10.0	1.36	0.833	14.0	0.971	1.170
x1/2	11.0	1.01	0.92	10.0	1.11	0.833	14.0	0.793	1.170
x3/8	11.0	0.770	0.92	10.0	0.847	0.833	14.0	0.605	1.170
x5/16	11.0	0.647	0.92	10.0	0.712	0.833	14.0	0.509	1.170
x1/4	11.0	0.523	0.92	10.0	0.575	0.833	14.0	0.411	1.170
L3-1/2x3-1/2x1/2	10.3	1.08	0.86	10.3	1.08	0.858	13.8	0.80	1.150
x7/16	10.3	0.953	0.86	10.3	0.953	0.858	13.8	0.712	1.150
x3/8	10.3	0.826	0.86	10.3	0.826	0.858	13.8	0.617	1.150
x5/16	10.3	0.695	0.86	10.3	0.695	0.858	13.8	0.519	1.150
x1/4	10.3	0.562	0.86	10.3	0.562	0.858	13.8	0.420	1.150
L3-1/2x3x1/2	9.84	1.05	0.82	9.34	1.10	0.778	12.8	0.805	1.070
x7/16	9.84	0.924	0.82	9.34	0.973	0.778	12.8	0.710	1.070
x3/8	9.84	0.801	0.82	9.34	0.844	0.778	12.8	0.616	1.070
x5/16	9.84	0.676	0.82	9.34	0.712	0.778	12.8	0.520	1.070
x1/4	9.84	0.547	0.82	9.34	0.576	0.778	12.8	0.420	1.070
L3-1/2x2-1/2x1/2	9.34	1.010	0.778	8.34	1.13	0.695	11.8	0.80	0.983
x3/8	9.34	0.774	0.778	8.34	0.867	0.695	11.8	0.613	0.983
x5/16	9.34	0.653	0.778	8.34	0.731	0.695	11.8	0.517	0.983
x1/4	9.34	0.529	0.778	8.34	0.592	0.695	11.8	0.419	0.983
L3x3x1/2	8.84	1.060	0.737	8.84	1.06	0.737	11.8	0.79	0.983
x7/16	8.84	0.937	0.737	8.84	0.937	0.737	11.8	0.702	0.983
x3/8	8.84	0.811	0.737	8.84	0.811	0.737	11.8	0.608	0.983
x5/16	8.84	0.683	0.737	8.84	0.683	0.737	11.8	0.512	0.983
x1/4	8.84	0.553	0.737	8.84	0.553	0.737	11.8	0.414	0.983
x3/16	8.84	0.419	0.737	8.84	0.419	0.737	11.8	0.314	0.983
L3x2-1/2x1/2	8.34	1.020	0.695	7.84	1.09	0.653	10.8	0.79	0.900
x7/16	8.34	0.906	0.695	7.84	0.964	0.653	10.8	0.700	0.900
x3/8	8.34	0.787	0.695	7.84	0.837	0.653	10.8	0.607	0.900
x5/16	8.34	0.664	0.695	7.84	0.707	0.653	10.8	0.513	0.900
x1/4	8.34	0.538	0.695	7.84	0.573	0.653	10.8	0.416	0.900
x3/16	8.34	0.409	0.695	7.84	0.435	0.653	10.8	0.316	0.900

Case A-1: Shape perimeter, minus short leg surface.  
Case A-2: Shape perimeter, minus long leg surface.

Case B: Shape perimeter.



### Talbe 5g (Continued)

Surface and Box Perimeters, Surface Areas and Weight-to-Perimeter Ratios for Angles

Shape	Case A-1 (See Fig. 1, Pg. 89)			Case A-2 (See Fig. 1, Pg. 89)			Case B (See Fig. 1, Pg. 89)		
	Perimeter	W/D Ratio	Surf. Area	Perimeter	W/D Ratio	Surf. Area	Perimeter	W/D Ratio	Surf. Area
	in.		ft <sup>2</sup> /ft	in.		ft <sup>2</sup> /ft	in.		ft <sup>2</sup> /ft
L3x2x1/2	7.87	0.978	0.656	6.87	1.12	0.573	9.87	0.78	0.823
x3/8	7.87	0.756	0.656	6.87	0.866	0.573	9.87	0.603	0.823
x5/16	7.87	0.639	0.656	6.87	0.732	0.573	9.87	0.510	0.823
x1/4	7.87	0.520	0.656	6.87	0.595	0.573	9.87	0.414	0.823
x3/16	7.87	0.396	0.656	6.87	0.454	0.573	9.87	0.316	0.823
L2-1/2x2-1/2x1/2	7.39	1.040	0.616	7.39	1.04	0.616	9.89	0.77	0.824
x3/8	7.39	0.798	0.616	7.39	0.798	0.616	9.89	0.597	0.824
x5/16	7.39	0.674	0.616	7.39	0.674	0.616	9.89	0.504	0.824
x1/4	7.39	0.547	0.616	7.39	0.547	0.616	9.89	0.408	0.824
x3/16	7.39	0.414	0.616	7.39	0.414	0.616	9.89	0.309	0.824
L2-1/2x2x3/8	6.89	0.769	0.574	6.39	0.829	0.533	8.89	0.596	0.741
x5/16	6.89	0.652	0.574	6.39	0.703	0.533	8.89	0.505	0.741
x1/4	6.89	0.530	0.574	6.39	0.571	0.533	8.89	0.411	0.741
x3/16	6.89	0.403	0.574	6.39	0.435	0.533	8.89	0.313	0.741
L2x2x3/8	5.89	0.789	0.491	5.89	0.789	0.491	7.89	0.589	0.658
x5/16	5.89	0.669	0.491	5.89	0.669	0.491	7.89	0.499	0.658
x1/4	5.89	0.545	0.491	5.89	0.545	0.491	7.89	0.407	0.658
x3/16	5.89	0.418	0.491	5.89	0.418	0.491	7.89	0.312	0.658
x1/8	5.89	0.284	0.491	5.89	0.284	0.491	7.89	0.212	0.658
Case A-1: Shape perimeter, minus short leg surface.				Case B: Shape perimeter.					
Case A-2: Shape perimeter, minus long leg surface.									





**Table 5h**

Surface and Box Perimeters, Surface Areas and Weight-to-Perimeter Ratios for WT-Shapes

Shape	Case A (See Fig. 1, Pg. 89)			Case B (See Fig. 1, Pg. 89)			Case C (See Fig. 1, Pg. 89)			Case D (See Fig. 1, Pg. 89)		
	Peri- meter	W/D Ratio	Surf. Area	Peri- meter	W/D Ratio	Surf. Area	Peri- meter	W/D Ratio	Surf. Area	Peri- meter	W/D Ratio	Surf. Area
	in.		ft <sup>2</sup> /ft	in.		ft <sup>2</sup> /ft	in.		ft <sup>2</sup> /ft	in.		ft <sup>2</sup> /ft
WT22x167.5	59.3	2.82	4.94	75.3	2.22	6.28	60.0	2.79	5.00	76.0	2.20	6.33
x145	58.7	2.47	4.89	74.5	1.95	6.21	59.4	2.44	4.95	75.2	1.93	6.27
x131	58.5	2.24	4.88	74.3	1.76	6.19	59.2	2.21	4.93	75.0	1.75	6.25
x115	58.1	1.98	4.84	73.9	1.56	6.16	58.8	1.96	4.90	74.6	1.54	6.22
WT20x296.5	58.6	5.06	4.88	75.3	3.94	6.28	59.7	4.97	4.98	76.4	3.88	6.37
x251.5	57.3	4.39	4.78	73.7	3.41	6.14	58.4	4.31	4.87	74.8	3.36	6.23
x215.5	56.3	3.83	4.69	72.5	2.97	6.04	57.4	3.75	4.78	73.6	2.93	6.13
x198.5	56.0	3.54	4.67	72.1	2.75	6.01	57.1	3.48	4.76	73.2	2.71	6.10
x186	55.6	3.35	4.63	71.7	2.59	5.98	56.7	3.28	4.73	72.8	2.55	6.07
x181*	55.5	3.26	4.63	71.5	2.53	5.96	56.6	3.20	4.72	72.6	2.49	6.05
x162	55.0	2.95	4.58	70.9	2.28	5.91	56.1	2.89	4.68	72.0	2.25	6.00
x148.5	54.5	2.72	4.54	70.3	2.11	5.86	55.6	2.67	4.63	71.4	2.08	5.95
x138.5	54.3	2.55	4.53	70.1	1.98	5.84	55.4	2.50	4.62	71.2	1.95	5.93
x124.5	54.1	2.30	4.51	69.9	1.78	5.83	55.2	2.26	4.60	71.0	1.75	5.92
x107.5	53.7	2.00	4.48	69.5	1.55	5.79	54.8	1.96	4.57	70.6	1.52	5.88
x99.5	53.3	1.87	4.44	69.1	1.44	5.76	54.4	1.83	4.53	70.2	1.42	5.85
WT20x196	52.9	3.71	4.41	65.3	3.00	5.44	54.0	3.63	4.50	66.4	2.95	5.53
x165.5	51.9	3.19	4.33	64.1	2.58	5.34	53.0	3.12	4.42	65.2	2.54	5.43
x163.5	51.8	3.16	4.32	63.9	2.56	5.33	52.9	3.09	4.41	65.0	2.52	5.42
x139	51.1	2.72	4.26	63.1	2.20	5.26	52.2	2.66	4.35	64.2	2.17	5.35
x132	50.8	2.60	4.23	62.7	2.11	5.23	51.9	2.54	4.33	63.8	2.07	5.32
x117.5	50.4	2.33	4.20	62.3	1.89	5.19	51.5	2.28	4.29	63.4	1.85	5.28
x105.5	50.1	2.11	4.18	61.9	1.70	5.16	51.2	2.06	4.27	63.0	1.67	5.25
x91.5	49.7	1.84	4.14	61.5	1.49	5.13	50.8	1.80	4.23	62.6	1.46	5.22
x83.5	49.3	1.69	4.11	61.1	1.37	5.09	50.4	1.66	4.20	62.2	1.34	5.18
x74.5	48.9	1.52	4.08	60.7	1.23	5.06	50.0	1.49	4.17	61.8	1.21	5.15
WT18x399	58.9	6.77	4.91	76.9	5.19	6.41	60.0	6.65	5.00	78.0	5.12	6.50
x325	56.9	5.71	4.74	74.5	4.36	6.21	58.0	5.60	4.83	75.6	4.30	6.30
x263.5	55.3	4.76	4.61	72.5	3.63	6.04	56.4	4.67	4.70	73.6	3.58	6.13
x219.5	54.1	4.06	4.51	71.1	3.09	5.93	55.2	3.98	4.60	72.2	3.04	6.02
x196.5	53.5	3.67	4.46	70.3	2.80	5.86	54.6	3.60	4.55	71.4	2.75	5.95
x179.5	53.0	3.39	4.42	69.7	2.58	5.81	54.1	3.32	4.51	70.8	2.54	5.90
x164	52.5	3.12	4.38	69.1	2.37	5.76	53.6	3.06	4.47	70.2	2.34	5.85
x150	52.4	2.86	4.37	69.1	2.17	5.76	53.5	2.80	4.46	70.2	2.14	5.85
x140	52.1	2.69	4.34	68.7	2.04	5.73	53.2	2.63	4.43	69.8	2.01	5.82
x130	51.7	2.51	4.31	68.3	1.90	5.69	52.8	2.46	4.40	69.4	1.87	5.78
x122.5	51.4	2.38	4.28	67.9	1.80	5.66	52.5	2.33	4.38	69.0	1.78	5.75
x115	51.4	2.24	4.28	67.9	1.69	5.66	52.5	2.19	4.38	69.0	1.67	5.75

Case A: Shape perimeter, minus one flange surface.

Case C: Box perimeter, minus one flange surface.

Case B: Shape perimeter.

Case D: Box perimeter.



**Table 5h (Continued)**

Surface and Box Perimeters, Surface Areas and Weight-to-Perimeter Ratios for WT-Shapes

Shape	Case A (See Fig. 1, Pg. 89)			Case B (See Fig. 1, Pg. 89)			Case C (See Fig. 1, Pg. 89)			Case D (See Fig. 1, Pg. 89)		
	Peri- meter	W/D Ratio	Surf. Area	Peri- meter	W/D Ratio	Surf. Area	Peri- meter	W/D Ratio	Surf. Area	Peri- meter	W/D Ratio	Surf. Area
	In.		ft <sup>2</sup> /ft	In.		ft <sup>2</sup> /ft	In.		ft <sup>2</sup> /ft	In.		ft <sup>2</sup> /ft
WT18x128	48.8	2.62	4.07	61.0	2.10	5.08	49.6	2.58	4.13	61.8	2.07	5.15
x116	48.6	2.39	4.05	60.7	1.91	5.06	49.3	2.35	4.11	61.4	1.89	5.12
x105	48.0	2.19	4.00	60.2	1.74	5.02	48.8	2.15	4.07	61.0	1.72	5.08
x97	47.7	2.03	3.98	59.8	1.62	4.98	48.5	2.00	4.04	60.6	1.60	5.05
x91	47.7	1.91	3.98	59.8	1.52	4.98	48.5	1.88	4.04	60.6	1.50	5.05
x85	47.4	1.79	3.95	59.4	1.43	4.95	48.2	1.76	4.02	60.2	1.41	5.02
x80	47.2	1.69	3.93	59.2	1.35	4.93	48.0	1.67	4.00	60.0	1.33	5.00
x75	47.0	1.60	3.92	59.0	1.27	4.92	47.8	1.57	3.98	59.8	1.25	4.98
x67.5	46.8	1.44	3.90	58.8	1.15	4.90	47.6	1.42	3.97	59.6	1.13	4.97
WT16.5x193.5	51.4	3.76	4.28	67.6	2.86	5.63	52.2	3.71	4.35	68.4	2.83	5.70
x177	51.0	3.47	4.25	67.1	2.64	5.59	51.7	3.42	4.31	67.8	2.61	5.65
x159	50.5	3.15	4.21	66.5	2.39	5.54	51.2	3.11	4.27	67.2	2.37	5.60
x145.5	49.9	2.92	4.16	65.8	2.21	5.48	50.7	2.87	4.23	66.6	2.18	5.55
x131.5	49.7	2.65	4.14	65.5	2.01	5.46	50.4	2.61	4.20	66.2	1.99	5.52
x120.5	49.4	2.44	4.12	65.3	1.85	5.44	50.1	2.41	4.18	66.0	1.83	5.50
x110.5	49.1	2.25	4.09	64.9	1.70	5.41	49.8	2.22	4.15	65.6	1.68	5.47
x100.5	48.6	2.07	4.05	64.3	1.56	5.36	49.3	2.04	4.11	65.0	1.55	5.42
WT16.5x84.5	44.5	1.90	3.71	56.0	1.51	4.67	45.3	1.87	3.78	56.8	1.49	4.73
x76	44.2	1.72	3.68	55.8	1.36	4.65	45.0	1.69	3.75	56.6	1.34	4.72
x70.5	44.2	1.60	3.68	55.7	1.27	4.64	44.9	1.57	3.74	56.4	1.25	4.70
x65	43.7	1.49	3.64	55.2	1.18	4.60	44.5	1.46	3.71	56.0	1.16	4.67
x59	43.5	1.36	3.63	55.0	1.07	4.58	44.3	1.33	3.69	55.8	1.06	4.65
WT15x195.5	48.0	4.07	4.00	63.6	3.07	5.30	48.8	4.01	4.07	64.4	3.04	5.37
x178.5	47.5	3.76	3.96	63.0	2.83	5.25	48.3	3.70	4.03	63.8	2.80	5.32
x163	47.0	3.47	3.92	62.4	2.61	5.20	47.8	3.41	3.98	63.2	2.58	5.27
x146	46.5	3.14	3.88	61.8	2.36	5.15	47.3	3.09	3.94	62.6	2.33	5.22
x130.5	46.0	2.84	3.83	61.2	2.13	5.10	46.8	2.79	3.90	62.0	2.10	5.17
x117.5	45.7	2.57	3.81	60.8	1.93	5.07	46.5	2.53	3.88	61.6	1.91	5.13
x105.5	45.3	2.33	3.78	60.4	1.75	5.03	46.1	2.29	3.84	61.2	1.72	5.10
x95.5	44.9	2.13	3.74	59.9	1.59	4.99	45.6	2.09	3.80	60.6	1.58	5.05
x86.5	44.6	1.94	3.72	59.6	1.45	4.97	45.4	1.91	3.78	60.4	1.43	5.03
WT15x74	40.3	1.84	3.36	50.8	1.46	4.23	41.1	1.80	3.43	51.6	1.43	4.30
x66	40.1	1.65	3.34	50.6	1.30	4.22	40.9	1.61	3.41	51.4	1.28	4.28
x62	39.9	1.55	3.33	50.4	1.23	4.20	40.7	1.52	3.39	51.2	1.21	4.27
x58	39.7	1.46	3.31	50.2	1.16	4.18	40.5	1.43	3.38	51.0	1.14	4.25
x54	39.5	1.37	3.29	50.0	1.08	4.17	40.3	1.34	3.36	50.8	1.06	4.23
x49.5	39.3	1.26	3.28	49.8	0.994	4.15	40.1	1.23	3.34	50.6	0.978	4.22
x45	39.2	1.15	3.27	49.6	0.907	4.13	40.0	1.13	3.33	50.4	0.893	4.20

Case A: Shape perimeter, minus one flange surface.

Case C: Box perimeter, minus one flange surface.

Case B: Shape perimeter.

Case D: Box perimeter.



**Table 5h (Continued)**

Surface and Box Perimeters, Surface Areas and Weight-to-Perimeter Ratios for WT-Shapes

Shape	Case A (See Fig. 1, Pg. 89)			Case B (See Fig. 1, Pg. 89)			Case C (See Fig. 1, Pg. 89)			Case D (See Fig. 1, Pg. 89)		
	Peri- meter	W/D Ratio	Surf. Area	Peri- meter	W/D Ratio	Surf. Area	Peri- meter	W/D Ratio	Surf. Area	Peri- meter	W/D Ratio	Surf. Area
	in.		ft <sup>2</sup> /ft	in.		ft <sup>2</sup> /ft	in.		ft <sup>2</sup> /ft	in.		ft <sup>2</sup> /ft
WT13.5x269.5	47.1	5.72	3.93	62.4	4.32	5.20	47.9	5.63	3.99	63.2	4.26	5.27
x184	44.3	4.15	3.69	59.0	3.12	4.92	45.1	4.08	3.76	59.8	3.08	4.98
x168	43.8	3.84	3.65	58.4	2.88	4.87	44.6	3.77	3.72	59.2	2.84	4.93
x153.5	43.2	3.55	3.60	57.6	2.66	4.80	44.0	3.49	3.67	58.4	2.63	4.87
x140.5	42.8	3.28	3.57	57.2	2.46	4.77	43.6	3.22	3.63	58.0	2.42	4.83
x129	42.5	3.04	3.54	56.8	2.27	4.73	43.3	2.98	3.61	57.6	2.24	4.80
x117.5	42.0	2.80	3.50	56.2	2.09	4.68	42.8	2.75	3.57	57.0	2.06	4.75
x108.5	41.7	2.60	3.48	55.8	1.94	4.65	42.5	2.55	3.54	56.6	1.92	4.72
x97	41.4	2.34	3.45	55.4	1.75	4.62	42.2	2.30	3.52	56.2	1.73	4.68
x89	41.2	2.16	3.43	55.3	1.61	4.61	41.9	2.12	3.49	56.0	1.59	4.67
x80.5	40.8	1.97	3.40	54.8	1.47	4.57	41.6	1.94	3.47	55.6	1.45	4.63
x73	40.6	1.80	3.38	54.6	1.34	4.55	41.4	1.76	3.45	55.4	1.32	4.62
WT13.5x64.5	36.8	1.75	3.07	46.8	1.38	3.90	37.6	1.72	3.13	47.6	1.36	3.97
x57	36.5	1.56	3.04	46.6	1.22	3.88	37.3	1.53	3.11	47.4	1.20	3.95
x51	36.2	1.41	3.02	46.2	1.10	3.85	37.0	1.38	3.08	47.0	1.09	3.92
x47	36.2	1.30	3.02	46.2	1.02	3.85	37.0	1.27	3.08	47.0	1.00	3.92
x42	36.0	1.17	3.00	45.9	0.915	3.83	36.8	1.14	3.07	46.7	0.899	3.89
WT12x185	40.9	4.52	3.41	54.6	3.39	4.55	41.7	4.44	3.48	55.4	3.34	4.62
x167.5	40.3	4.16	3.36	53.8	3.11	4.48	41.1	4.08	3.43	54.6	3.07	4.55
x153	39.8	3.84	3.32	53.2	2.88	4.43	40.6	3.77	3.38	54.0	2.83	4.50
x139.5	39.3	3.55	3.28	52.6	2.65	4.38	40.1	3.48	3.34	53.4	2.61	4.45
x125	38.8	3.22	3.23	52.0	2.40	4.33	39.6	3.16	3.30	52.8	2.37	4.40
x114.5	38.3	2.99	3.19	51.4	2.23	4.28	39.1	2.93	3.26	52.2	2.19	4.35
x103.5	38.0	2.72	3.17	51.0	2.03	4.25	38.8	2.67	3.23	51.8	2.00	4.32
x96	37.6	2.55	3.13	50.6	1.90	4.22	38.4	2.50	3.20	51.4	1.87	4.28
x88	37.3	2.36	3.11	50.2	1.75	4.18	38.1	2.31	3.18	51.0	1.73	4.25
x81	37.2	2.18	3.10	50.2	1.61	4.18	38.0	2.13	3.17	51.0	1.59	4.25
x73	36.9	1.98	3.08	49.8	1.47	4.15	37.7	1.94	3.14	50.6	1.44	4.22
x65.5	36.5	1.79	3.04	49.4	1.33	4.12	37.3	1.76	3.11	50.2	1.30	4.18
x58.5	36.2	1.62	3.02	49.0	1.19	4.08	37.0	1.58	3.08	49.8	1.17	4.15
x52	36.0	1.44	3.00	48.8	1.07	4.07	36.8	1.41	3.07	49.6	1.05	4.13
WT12x51.5	32.8	1.57	2.73	41.8	1.23	3.48	33.6	1.53	2.80	42.6	1.21	3.55
x47	32.7	1.44	2.73	41.8	1.12	3.48	33.5	1.40	2.79	42.5	1.11	3.54
x42	32.4	1.30	2.70	41.5	1.01	3.46	33.2	1.27	2.77	42.2	0.995	3.52
x38	32.2	1.18	2.68	41.2	0.922	3.43	33.0	1.15	2.75	42.0	0.905	3.50
x34	32.0	1.06	2.67	41.0	0.829	3.42	32.8	1.04	2.73	41.7	0.815	3.48
WT12x31	30.1	1.03	2.51	37.1	0.836	3.09	30.8	1.01	2.57	37.9	0.818	3.16
x27.5	29.8	0.923	2.48	36.8	0.747	3.07	30.6	0.899	2.55	37.6	0.731	3.13

Case A: Shape perimeter, minus one flange surface.

Case C: Box perimeter, minus one flange surface.

Case B: Shape perimeter.

Case D: Box perimeter.



**Table 5h (Continued)**

Surface and Box Perimeters, Surface Areas and Weight-to-Perimeter Ratios for WT-Shapes

Shape	Case A (See Fig. 1, Pg. 89)			Case B (See Fig. 1, Pg. 89)			Case C (See Fig. 1, Pg. 89)			Case D (See Fig. 1, Pg. 89)		
	Peri- meter	W/D Ratio	Surf. Area	Peri- meter	W/D Ratio	Surf. Area	Peri- meter	W/D Ratio	Surf. Area	Peri- meter	W/D Ratio	Surf. Area
	in.		ft <sup>2</sup> /ft	in.		ft <sup>2</sup> /ft	in.		ft <sup>2</sup> /ft	in.		ft <sup>2</sup> /ft
WT10.5x100.5	34.9	2.88	2.91	47.5	2.12	3.96	35.6	2.82	2.97	48.2	2.09	4.02
x91	34.5	2.64	2.88	47.0	1.94	3.92	35.3	2.58	2.94	47.8	1.90	3.98
x83	34.0	2.44	2.83	46.4	1.79	3.87	34.8	2.39	2.90	47.2	1.76	3.93
x73.5	33.8	2.17	2.82	46.3	1.59	3.86	34.5	2.13	2.88	47.0	1.56	3.92
x66	33.4	1.98	2.78	45.8	1.44	3.82	34.2	1.93	2.85	46.6	1.42	3.88
x61	33.3	1.83	2.78	45.7	1.33	3.81	34.0	1.79	2.83	46.4	1.31	3.87
x55.5	33.1	1.68	2.76	45.4	1.22	3.78	33.9	1.64	2.83	46.2	1.20	3.85
x50.5	32.9	1.53	2.74	45.2	1.12	3.77	33.7	1.50	2.81	46.0	1.10	3.83
WT10.5x46.5	29.4	1.58	2.45	37.8	1.23	3.15	30.0	1.55	2.50	38.4	1.21	3.20
x41.5	29.2	1.42	2.43	37.5	1.11	3.13	29.8	1.39	2.48	38.1	1.09	3.18
x36.5	28.9	1.26	2.41	37.2	0.981	3.10	29.5	1.24	2.46	37.8	0.966	3.15
x34	28.9	1.18	2.41	37.1	0.916	3.09	29.5	1.15	2.46	37.7	0.902	3.14
x31	28.6	1.08	2.38	36.9	0.840	3.08	29.2	1.06	2.43	37.5	0.827	3.13
x27.5	28.4	0.968	2.37	36.7	0.749	3.06	29.0	0.948	2.42	37.2	0.739	3.10
x24	28.1	0.854	2.34	36.3	0.661	3.03	28.7	0.836	2.39	36.9	0.650	3.08
WT10.5x28.5	27.0	1.06	2.25	33.6	0.848	2.80	27.6	1.03	2.30	34.1	0.836	2.84
x25	26.7	0.936	2.23	33.2	0.753	2.77	27.3	0.916	2.28	33.9	0.737	2.83
x22	26.5	0.830	2.21	33.0	0.667	2.75	27.1	0.812	2.26	33.6	0.655	2.80
WT9x87.5	30.7	2.85	2.56	42.1	2.08	3.51	31.4	2.79	2.62	42.8	2.04	3.57
x79	30.2	2.62	2.52	41.5	1.90	3.46	31.0	2.55	2.58	42.3	1.87	3.53
x71.5	29.9	2.39	2.49	41.1	1.74	3.43	30.7	2.33	2.56	41.9	1.71	3.49
x65	29.7	2.19	2.48	40.9	1.59	3.41	30.5	2.13	2.54	41.7	1.56	3.48
x59.5	29.5	2.02	2.46	40.8	1.46	3.40	30.3	1.96	2.53	41.6	1.43	3.47
x53	29.2	1.82	2.43	40.4	1.31	3.37	29.9	1.77	2.49	41.1	1.29	3.43
x48.5	28.9	1.68	2.41	40.0	1.21	3.33	29.7	1.63	2.48	40.8	1.19	3.40
x43	28.8	1.49	2.40	39.9	1.08	3.33	29.5	1.46	2.46	40.6	1.06	3.38
x38	28.5	1.33	2.38	39.5	0.962	3.29	29.2	1.30	2.43	40.2	0.945	3.35
WT9x35.5	25.5	1.39	2.13	33.1	1.07	2.76	26.1	1.36	2.18	33.7	1.05	2.81
x32.5	25.4	1.28	2.12	32.9	0.988	2.74	26.0	1.25	2.17	33.5	0.970	2.79
x30	25.2	1.19	2.10	32.8	0.915	2.73	25.8	1.16	2.15	33.4	0.898	2.78
x27.5	25.1	1.10	2.09	32.6	0.844	2.72	25.7	1.07	2.14	33.2	0.828	2.77
x25	24.9	1.000	2.08	32.4	0.772	2.70	25.5	0.980	2.13	33.0	0.758	2.75
WT9x23	23.6	0.975	1.97	29.6	0.777	2.47	24.1	0.954	2.01	30.2	0.762	2.52
x20	23.4	0.855	1.95	29.4	0.680	2.45	23.9	0.837	1.99	29.9	0.669	2.49
x17.5	23.1	0.758	1.93	29.1	0.601	2.43	23.7	0.738	1.98	29.7	0.589	2.48

Case A: Shape perimeter, minus one flange surface.

Case C: Box perimeter, minus one flange surface.

Case B: Shape perimeter.

Case D: Box perimeter.



**Table 5h (Continued)**

Surface and Box Perimeters, Surface Areas and Weight-to-Perimeter Ratios for WT-Shapes

Shape	Case A (See Fig. 1, Pg. 89)			Case B (See Fig. 1, Pg. 89)			Case C (See Fig. 1, Pg. 89)			Case D (See Fig. 1, Pg. 89)		
	Peri- meter	W/D Ratio	Surf. Area	Peri- meter	W/D Ratio	Surf. Area	Peri- meter	W/D Ratio	Surf. Area	Peri- meter	W/D Ratio	Surf. Area
	in.		ft <sup>2</sup> /ft	in.		ft <sup>2</sup> /ft	in.		ft <sup>2</sup> /ft	in.		ft <sup>2</sup> /ft
WT8x50	26.6	1.88	2.22	37.0	1.35	3.08	27.4	1.82	2.28	37.8	1.32	3.15
x44.5	26.4	1.69	2.20	36.8	1.21	3.07	27.2	1.64	2.27	37.6	1.18	3.13
x38.5	26.1	1.48	2.18	36.4	1.06	3.03	26.8	1.44	2.23	37.1	1.04	3.09
x33.5	25.7	1.30	2.14	35.9	0.933	2.99	26.5	1.26	2.21	36.7	0.913	3.06
WT8x28.5	23.0	1.24	1.92	30.1	0.947	2.51	23.6	1.21	1.97	30.7	0.928	2.56
x25	22.7	1.10	1.89	29.8	0.839	2.48	23.3	1.07	1.94	30.4	0.822	2.53
x22.5	22.6	0.996	1.88	29.6	0.760	2.47	23.2	0.970	1.93	30.2	0.745	2.52
x20	22.4	0.893	1.87	29.4	0.680	2.45	23.0	0.870	1.92	30.0	0.667	2.50
x18	22.3	0.807	1.86	29.2	0.616	2.43	22.9	0.786	1.91	29.8	0.604	2.48
WT8x15.5	20.8	0.745	1.73	26.4	0.587	2.20	21.4	0.724	1.78	26.9	0.576	2.24
x13	20.6	0.631	1.72	26.1	0.498	2.18	21.2	0.613	1.77	26.7	0.487	2.23
WT7x404	40.3	10.00	3.36	58.9	6.86	4.91	41.4	9.76	3.45	60.0	6.73	5.00
x365	39.2	9.31	3.27	57.1	6.39	4.76	40.3	9.06	3.36	58.2	6.27	4.85
x332.5	38.2	8.70	3.18	55.9	5.95	4.66	39.3	8.46	3.28	57.0	5.83	4.75
x302.5	37.3	8.11	3.11	54.7	5.53	4.56	38.4	7.88	3.20	55.8	5.42	4.65
x275	36.3	7.58	3.03	53.5	5.14	4.46	37.4	7.35	3.12	54.6	5.04	4.55
x250	35.5	7.04	2.96	52.5	4.76	4.38	36.6	6.83	3.05	53.6	4.66	4.47
x227.5	34.7	6.56	2.89	51.5	4.42	4.29	35.8	6.35	2.98	52.6	4.33	4.38
x213	34.3	6.21	2.86	51.0	4.18	4.25	35.4	6.02	2.95	52.1	4.09	4.34
x199	33.8	5.89	2.82	50.4	3.95	4.20	34.9	5.70	2.91	51.5	3.86	4.29
x185	33.3	5.56	2.78	49.8	3.71	4.15	34.4	5.38	2.87	50.9	3.63	4.24
x171	32.8	5.21	2.73	49.2	3.48	4.10	33.9	5.04	2.83	50.3	3.40	4.19
x155.5	32.2	4.83	2.68	48.4	3.21	4.03	33.3	4.67	2.78	49.5	3.14	4.13
x141.5	31.7	4.46	2.64	47.8	2.96	3.98	32.8	4.31	2.73	48.9	2.89	4.08
x128.5	31.3	4.11	2.61	47.3	2.72	3.94	32.4	3.97	2.70	48.4	2.65	4.03
x116.5	30.8	3.78	2.57	46.7	2.49	3.89	31.9	3.65	2.66	47.8	2.44	3.98
x105.5	30.4	3.47	2.53	46.2	2.28	3.85	31.5	3.35	2.63	47.3	2.23	3.94
x96.5	30.1	3.21	2.51	45.8	2.11	3.82	31.2	3.09	2.60	46.9	2.06	3.91
x88	29.8	2.95	2.48	45.5	1.93	3.79	30.9	2.85	2.58	46.6	1.89	3.88
x79.5	29.5	2.69	2.46	45.1	1.76	3.76	30.6	2.60	2.55	46.2	1.72	3.85
x72.5	29.2	2.48	2.43	44.7	1.62	3.73	30.3	2.39	2.53	45.8	1.58	3.82
WT7x66	28.3	2.33	2.36	43.0	1.53	3.58	29.4	2.24	2.45	44.1	1.50	3.68
x60	28.1	2.14	2.34	42.8	1.40	3.57	29.2	2.05	2.43	43.9	1.37	3.66
x54.5	27.8	1.96	2.32	42.4	1.29	3.53	28.9	1.89	2.41	43.5	1.25	3.63
x49.5	27.7	1.79	2.31	42.3	1.17	3.53	28.8	1.72	2.40	43.4	1.14	3.62
x45	27.4	1.64	2.28	41.9	1.07	3.49	28.5	1.58	2.38	43.0	1.05	3.58

Case A: Shape perimeter, minus one flange surface.

Case C: Box perimeter, minus one flange surface.

Case B: Shape perimeter.

Case D: Box perimeter.



**Table 5h (Continued)**

Surface and Box Perimeters, Surface Areas and Weight-to-Perimeter Ratios for WT-Shapes

Shape	Case A (See Fig. 1, Pg. 89)			Case B (See Fig. 1, Pg. 89)			Case C (See Fig. 1, Pg. 89)			Case D (See Fig. 1, Pg. 89)		
	Peri- meter	W/D Ratio	Surf. Area	Peri- meter	W/D Ratio	Surf. Area	Peri- meter	W/D Ratio	Surf. Area	Peri- meter	W/D Ratio	Surf. Area
	in.		ft <sup>2</sup> /ft	in.		ft <sup>2</sup> /ft	in.		ft <sup>2</sup> /ft	in.		ft <sup>2</sup> /ft
WT7x41	23.7	1.73	1.98	33.8	1.21	2.82	24.4	1.68	2.03	34.5	1.19	2.88
x37	23.6	1.57	1.97	33.7	1.10	2.81	24.3	1.52	2.03	34.4	1.08	2.87
x34	23.3	1.46	1.94	33.3	1.02	2.78	24.0	1.42	2.00	34.0	1.00	2.83
x30.5	23.2	1.31	1.93	33.1	0.921	2.76	23.9	1.28	1.99	33.9	0.900	2.83
WT7x26.5	21.3	1.24	1.78	29.3	0.904	2.44	22.0	1.20	1.83	30.0	0.883	2.50
x24	21.1	1.14	1.76	29.1	0.825	2.43	21.8	1.10	1.82	29.9	0.803	2.49
x21.5	20.9	1.03	1.74	28.9	0.744	2.41	21.7	0.991	1.81	29.7	0.724	2.48
WT7x19	20.2	0.941	1.68	27.0	0.704	2.25	20.9	0.909	1.74	27.6	0.688	2.30
x17	20.1	0.846	1.68	26.9	0.632	2.24	20.7	0.821	1.73	27.5	0.618	2.29
x15	19.9	0.754	1.66	26.7	0.562	2.23	20.6	0.728	1.72	27.3	0.549	2.28
WT7x13	18.3	0.710	1.53	23.4	0.556	1.95	19.0	0.684	1.58	24.0	0.542	2.00
x11	18.1	0.608	1.51	23.1	0.476	1.93	18.7	0.588	1.56	23.7	0.464	1.98
WT6x168	29.4	5.71	2.45	42.8	3.93	3.57	30.2	5.56	2.52	43.6	3.85	3.63
x152.5	28.7	5.31	2.39	41.9	3.64	3.49	29.5	5.17	2.46	42.7	3.57	3.56
x139.5	28.2	4.95	2.35	41.3	3.38	3.44	29.0	4.81	2.42	42.1	3.31	3.51
x126	27.7	4.55	2.31	40.7	3.10	3.39	28.4	4.44	2.37	41.4	3.04	3.45
x115	27.2	4.23	2.27	40.1	2.87	3.34	28.0	4.11	2.33	40.9	2.81	3.41
x105	26.7	3.93	2.23	39.5	2.66	3.29	27.5	3.82	2.29	40.3	2.61	3.36
x95	26.3	3.61	2.19	39.0	2.44	3.25	27.1	3.51	2.26	39.8	2.39	3.32
x85	25.9	3.28	2.16	38.5	2.21	3.21	26.6	3.20	2.22	39.2	2.17	3.27
x76	25.4	2.99	2.12	37.9	2.01	3.16	26.2	2.90	2.18	38.7	1.96	3.23
x68	25.1	2.71	2.09	37.5	1.81	3.13	25.8	2.64	2.15	38.2	1.78	3.18
x60	24.7	2.43	2.06	37.0	1.62	3.08	25.4	2.36	2.12	37.7	1.59	3.14
x53	24.3	2.18	2.03	36.5	1.45	3.04	25.1	2.11	2.09	37.3	1.42	3.11
x48	24.1	1.99	2.01	36.3	1.32	3.03	24.9	1.93	2.08	37.1	1.29	3.09
x43.5	23.9	1.82	1.99	36.0	1.21	3.00	24.6	1.77	2.05	36.7	1.19	3.06
x39.5	23.7	1.67	1.98	35.8	1.10	2.98	24.5	1.61	2.04	36.6	1.08	3.05
x36	23.5	1.53	1.96	35.5	1.01	2.96	24.3	1.48	2.03	36.3	0.992	3.03
x32.5	23.4	1.39	1.95	35.4	0.918	2.95	24.1	1.35	2.01	36.1	0.900	3.01
WT6x29	21.5	1.35	1.79	31.5	0.921	2.63	22.2	1.31	1.85	32.2	0.901	2.68
x26.5	21.4	1.24	1.78	31.4	0.844	2.62	22.1	1.20	1.84	32.0	0.828	2.67
WT6x25	19.5	1.28	1.63	27.6	0.906	2.30	20.3	1.23	1.69	28.4	0.880	2.37
x22.5	19.4	1.16	1.62	27.5	0.818	2.29	20.1	1.12	1.68	28.2	0.798	2.35
x20	19.2	1.04	1.60	27.2	0.735	2.27	20.0	1.00	1.67	28.0	0.714	2.33
WT6x17.5	18.5	0.946	1.54	25.0	0.700	2.08	19.1	0.916	1.59	25.6	0.684	2.13
x15	18.3	0.820	1.53	24.8	0.605	2.07	18.9	0.794	1.58	25.4	0.591	2.12
x13	18.1	0.718	1.51	24.6	0.528	2.05	18.7	0.695	1.56	25.2	0.516	2.10

Case A: Shape perimeter, minus one flange surface.  
Case B: Shape perimeter.  
Case C: Box perimeter, minus one flange surface.  
Case D: Box perimeter.



**Table 5h (Continued)**

Surface and Box Perimeters, Surface Areas and Weight-to-Perimeter Ratios for WT-Shapes

Shape	Case A (See Fig. 1, Pg. 89)			Case B (See Fig. 1, Pg. 89)			Case C (See Fig. 1, Pg. 89)			Case D (See Fig. 1, Pg. 89)		
	Peri- meter	W/D Ratio	Surf. Area	Peri- meter	W/D Ratio	Surf. Area	Peri- meter	W/D Ratio	Surf. Area	Peri- meter	W/D Ratio	Surf. Area
	in.		ft <sup>2</sup> /ft	in.		ft <sup>2</sup> /ft	in.		ft <sup>2</sup> /ft	in.		ft <sup>2</sup> /ft
WT6x11	15.9	0.692	1.33	19.9	0.553	1.66	16.4	0.671	1.37	20.4	0.539	1.70
x9.5	15.7	0.605	1.31	19.7	0.482	1.64	16.2	0.586	1.35	20.2	0.470	1.68
x8	15.5	0.516	1.29	19.5	0.410	1.63	16.0	0.500	1.33	20.0	0.400	1.67
x7	15.4	0.455	1.28	19.4	0.361	1.62	15.9	0.440	1.33	19.9	0.352	1.66
WT5x56	21.2	2.64	1.77	31.6	1.77	2.63	21.8	2.57	1.82	32.2	1.74	2.68
x50	20.8	2.40	1.73	31.1	1.61	2.59	21.4	2.34	1.78	31.7	1.58	2.64
x44	20.5	2.15	1.71	30.8	1.43	2.57	21.1	2.09	1.76	31.4	1.40	2.62
x38.5	20.2	1.91	1.68	30.4	1.27	2.53	20.8	1.85	1.73	31.0	1.24	2.58
x34	19.9	1.71	1.66	30.0	1.13	2.50	20.5	1.66	1.71	30.6	1.11	2.55
x30	19.7	1.52	1.64	29.8	1.01	2.48	20.3	1.48	1.69	30.4	0.987	2.53
x27	19.5	1.38	1.63	29.5	0.915	2.46	20.1	1.34	1.68	30.1	0.897	2.51
x24.5	19.4	1.26	1.62	29.4	0.833	2.45	20.0	1.23	1.67	30.0	0.817	2.50
WT5x22.5	17.5	1.29	1.46	25.5	0.882	2.13	18.1	1.24	1.51	26.1	0.862	2.18
x19.5	17.3	1.13	1.44	25.3	0.771	2.11	17.9	1.09	1.49	25.9	0.753	2.16
x16.5	17.1	0.965	1.43	25.1	0.657	2.09	17.7	0.932	1.48	25.7	0.642	2.14
WT5x15	15.8	0.949	1.32	21.6	0.694	1.80	16.3	0.920	1.36	22.1	0.679	1.84
x13	15.6	0.833	1.30	21.3	0.610	1.78	16.1	0.807	1.34	21.9	0.594	1.83
x11	15.4	0.714	1.28	21.2	0.519	1.77	15.9	0.692	1.33	21.7	0.507	1.81
WT5x9.5	13.8	0.688	1.15	17.8	0.534	1.48	14.3	0.664	1.19	18.3	0.519	1.53
x8.5	13.6	0.625	1.13	17.7	0.480	1.48	14.1	0.603	1.18	18.1	0.470	1.51
x7.5	13.5	0.556	1.13	17.5	0.429	1.46	14.0	0.536	1.17	18.0	0.417	1.50
x6	13.4	0.448	1.12	17.3	0.347	1.44	13.8	0.435	1.15	17.8	0.337	1.48
WT4x33.5	16.7	2.01	1.39	25.0	1.34	2.08	17.3	1.94	1.44	25.6	1.31	2.13
x29	16.4	1.77	1.37	24.6	1.18	2.05	17.0	1.71	1.42	25.2	1.15	2.10
x24	16.0	1.50	1.33	24.1	0.996	2.01	16.6	1.45	1.38	24.7	0.972	2.06
x20	15.7	1.27	1.31	23.8	0.840	1.98	16.3	1.23	1.36	24.4	0.820	2.03
x17.5	15.5	1.13	1.29	23.6	0.742	1.97	16.1	1.09	1.34	24.2	0.723	2.02
x15.5	15.4	1.010	1.28	23.4	0.662	1.95	16.0	0.969	1.33	24.0	0.646	2.00
WT4x14	14.2	0.986	1.18	20.7	0.676	1.73	14.6	0.959	1.22	21.1	0.664	1.76
x12	14.0	0.857	1.17	20.5	0.585	1.71	14.4	0.833	1.20	20.9	0.574	1.74
WT4x10.5	13.1	0.802	1.09	18.4	0.571	1.53	13.6	0.772	1.13	18.8	0.559	1.57
x9	13.0	0.692	1.08	18.2	0.495	1.52	13.4	0.672	1.12	18.6	0.484	1.55
WT4x7.5	11.7	0.641	0.975	15.7	0.478	1.31	12.1	0.620	1.01	16.1	0.466	1.34
x6.5	11.6	0.560	0.967	15.6	0.417	1.30	12.0	0.542	1.00	16.0	0.406	1.33
x5	11.4	0.439	0.950	15.4	0.325	1.28	11.8	0.424	0.983	15.8	0.316	1.32

Case A: Shape perimeter, minus one flange surface.

Case C: Box perimeter, minus one flange surface.

Case B: Shape perimeter.

Case D: Box perimeter.



**Table 5h (Continued)**

Surface and Box Perimeters, Surface Areas and Weight-to-Perimeter Ratios for WT-Shapes

Shape	Case A (See Fig. 1, Pg. 89)			Case B (See Fig. 1, Pg. 89)			Case C (See Fig. 1, Pg. 89)			Case D (See Fig. 1, Pg. 89)		
	Peri- meter	W/D Ratio	Surf. Area	Peri- meter	W/D Ratio	Surf. Area	Peri- meter	W/D Ratio	Surf. Area	Peri- meter	W/D Ratio	Surf. Area
	in.		ft <sup>2</sup> /ft	in.		ft <sup>2</sup> /ft	in.		ft <sup>2</sup> /ft	in.		ft <sup>2</sup> /ft
WT3x12.5	12.0	1.04	1.00	18.1	0.691	1.51	12.5	1.00	1.04	18.5	0.676	1.54
x10	11.8	0.847	0.98	17.8	0.562	1.48	12.2	0.820	1.02	18.2	0.549	1.52
x7.5	11.6	0.647	0.967	17.6	0.426	1.47	12.0	0.625	1.00	18.0	0.417	1.50
WT3x8	9.9	0.807	0.826	13.9	0.576	1.16	10.3	0.777	0.858	14.3	0.559	1.19
x6	9.64	0.622	0.803	13.6	0.441	1.13	10.00	0.600	0.833	14.0	0.429	1.17
x4.5	9.43	0.477	0.786	13.4	0.336	1.12	9.84	0.457	0.820	13.8	0.326	1.15
x4.25	9.36	0.454	0.780	13.3	0.320	1.11	9.78	0.435	0.815	13.7	0.310	1.14
WT2.5x9.5	9.86	0.963	0.822	14.9	0.638	1.24	10.2	0.931	0.850	15.2	0.625	1.27
x8	9.69	0.826	0.808	14.7	0.544	1.23	10.00	0.800	0.833	15.0	0.533	1.25
WT2x6.5	7.87	0.826	0.656	11.9	0.546	0.99	8.22	0.791	0.685	12.3	0.528	1.03
Case A: Shape perimeter, minus one flange surface.						Case C: Box perimeter, minus one flange surface.						
Case B: Shape perimeter.						Case D: Box perimeter.						





**Table 5i**

Surface and Box Perimeters, Surface Areas and Weight-to-Perimeter Ratios for MT-Shapes

Shape	Case A (See Fig. 1, Pg. 89)			Case B (See Fig. 1, Pg. 89)			Case C (See Fig. 1, Pg. 89)			Case D (See Fig. 1, Pg. 89)		
	Peri- meter	W/D Ratio	Surf. Area	Peri- meter	W/D Ratio	Surf. Area	Peri- meter	W/D Ratio	Surf. Area	Peri- meter	W/D Ratio	Surf. Area
	in.		ft <sup>2</sup> /ft	in.		ft <sup>2</sup> /ft	in.		ft <sup>2</sup> /ft	in.		ft <sup>2</sup> /ft
MT6x5.9 x5.4 x5	14.8	0.399	1.23	17.9	0.330	1.49	15.1	0.391	1.26	18.1	0.326	1.51
	14.7	0.367	1.23	17.8	0.303	1.48	15.1	0.358	1.26	18.1	0.298	1.51
	15.0	0.333	1.25	18.2	0.275	1.52	15.2	0.329	1.27	18.5	0.270	1.54
MT5x4.5 x4 x3.75	12.4	0.363	1.03	15.1	0.298	1.26	12.7	0.354	1.06	15.4	0.292	1.28
	12.3	0.325	1.03	15.0	0.267	1.25	12.6	0.317	1.05	15.3	0.261	1.28
	12.5	0.300	1.04	15.2	0.247	1.27	12.7	0.295	1.06	15.4	0.244	1.28
MT4x3.25 x3.1	9.96	0.326	0.830	12.2	0.266	1.02	10.3	0.316	0.858	12.6	0.258	1.05
	10.1	0.307	0.842	12.3	0.252	1.03	10.3	0.301	0.858	12.6	0.246	1.05
MT3x2.2 x1.85	7.66	0.287	0.638	9.50	0.232	0.792	7.84	0.281	0.653	9.68	0.227	0.807
	7.76	0.238	0.647	9.76	0.190	0.813	7.92	0.234	0.660	9.92	0.186	0.827
MT2.5x9.45	9.66	0.978	0.805	14.7	0.643	1.23	10.00	0.945	0.833	15.0	0.630	1.25
MT2x3	7.31	0.410	0.609	11.1	0.270	0.925	7.60	0.395	0.633	11.4	0.263	0.950
Case A: Shape perimeter, minus one flange surface.						Case C: Box perimeter, minus one flange surface.						
Case B: Shape perimeter.						Case D: Box perimeter.						



**Table 5j**

Surface and Box Perimeters, Surface Areas and Weight-to-Perimeter Ratios for ST-Shapes

Shape	Case A (See Fig. 1, Pg. 89)			Case B (See Fig. 1, Pg. 89)			Case C (See Fig. 1, Pg. 89)			Case D (See Fig. 1, Pg. 89)		
	Peri- meter	W/D Ratio	Surf. Area	Peri- meter	W/D Ratio	Surf. Area	Peri- meter	W/D Ratio	Surf. Area	Peri- meter	W/D Ratio	Surf. Area
	in.		ft <sup>2</sup> /ft	in.		ft <sup>2</sup> /ft	in.		ft <sup>2</sup> /ft	in.		ft <sup>2</sup> /ft
ST12x60.5 x53	31.2	1.94	2.60	39.2	1.54	3.27	32.7	1.85	2.73	40.7	1.49	3.39
	31.0	1.71	2.58	38.8	1.37	3.23	32.5	1.63	2.71	40.3	1.32	3.36
ST12x50 x45 x40	29.9	1.67	2.49	37.1	1.35	3.09	31.3	1.60	2.61	38.5	1.30	3.21
	29.8	1.51	2.48	36.9	1.22	3.08	31.1	1.45	2.59	38.3	1.17	3.19
	29.6	1.35	2.47	36.6	1.09	3.05	31.0	1.29	2.58	38.0	1.05	3.17
ST10x48 x43	26.3	1.83	2.19	33.5	1.43	2.79	27.6	1.74	2.30	34.8	1.38	2.90
	26.1	1.65	2.18	33.2	1.30	2.77	27.5	1.56	2.29	34.5	1.25	2.88
ST10x37.5 x33	25.1	1.49	2.09	31.5	1.19	2.63	26.4	1.42	2.20	32.8	1.14	2.73
	25.0	1.32	2.08	31.3	1.05	2.61	26.3	1.25	2.19	32.5	1.02	2.71
ST9x35 x27.35	23.0	1.52	1.92	29.3	1.19	2.44	24.3	1.44	2.03	30.5	1.15	2.54
	22.8	1.20	1.90	28.8	0.950	2.40	24.0	1.14	2.00	30.0	0.912	2.50
ST7.5x25 x21.45	19.5	1.28	1.63	25.2	0.992	2.10	20.6	1.21	1.72	26.3	0.951	2.19
	19.4	1.11	1.62	24.9	0.861	2.08	20.5	1.05	1.71	26.0	0.825	2.17
ST6x25 x20.4	16.4	1.52	1.37	21.9	1.14	1.83	17.5	1.43	1.46	23.0	1.09	1.92
	16.2	1.26	1.35	21.4	0.953	1.78	17.3	1.18	1.44	22.5	0.907	1.88
ST6x17.5 x15.9	16.1	1.09	1.34	21.2	0.825	1.77	17.1	1.02	1.43	22.2	0.788	1.85
	16.0	0.994	1.33	21.0	0.757	1.75	17.0	0.935	1.42	22.0	0.723	1.83
ST5x17.5 x12.7	14.0	1.25	1.17	18.9	0.926	1.58	14.9	1.17	1.24	19.9	0.879	1.66
	13.7	0.927	1.14	18.4	0.690	1.53	14.7	0.864	1.23	19.3	0.658	1.61
ST4x11.5 x9.2	11.3	1.02	0.942	15.5	0.742	1.29	12.2	0.943	1.02	16.3	0.706	1.36
	11.2	0.821	0.933	15.2	0.605	1.27	12.0	0.767	1.00	16.0	0.575	1.33
ST3x8.625 x6.25	8.89	0.970	0.741	12.5	0.690	1.04	9.57	0.901	0.798	13.1	0.658	1.09
	8.65	0.723	0.721	12.0	0.521	1.00	9.33	0.670	0.778	12.7	0.492	1.06
ST2.5x5	7.38	0.678	0.615	10.4	0.481	0.867	8.00	0.625	0.667	11.0	0.455	0.917
ST2x4.75 x3.85	6.20	0.766	0.517	9.00	0.528	0.750	6.80	0.699	0.567	9.60	0.495	0.800
	6.06	0.635	0.505	8.72	0.442	0.727	6.66	0.578	0.555	9.32	0.413	0.777
ST1.5x3.75 x2.85	5.01	0.749	0.418	7.52	0.499	0.627	5.51	0.681	0.459	8.02	0.468	0.668
	4.83	0.590	0.403	7.16	0.398	0.597	5.33	0.535	0.444	7.66	0.372	0.638

Case A: Shape perimeter, minus one flange surface.

Case C: Box perimeter, minus one flange surface.

Case B: Shape perimeter.

Case D: Box perimeter.



**Table 6a**

Surface and Box Perimeters, Surface Areas and Area-to-Perimeter Ratios for Rectangular (and Square) Hollow Structural Sections

Shape	Case A (See Fig. 1, Pg. 89)			Case B (See Fig. 1, Pg. 89)			Case C (See Fig. 1, Pg. 89)		
	Peri- meter	A/P Ratio	Surf. Area	Peri- meter	A/P Ratio	Surf. Area	Peri- meter	A/P Ratio	Surf. Area
	in.		ft <sup>2</sup> /ft	in.		ft <sup>2</sup> /ft	in.		ft <sup>2</sup> /ft
HSS20x12x5/8	52.3	0.668	4.36	44.3	0.789	3.69	62.0	0.564	5.17
x1/2	52.3	0.542	4.36	44.3	0.640	3.69	62.4	0.454	5.20
x3/8	52.2	0.413	4.35	44.2	0.487	3.68	62.8	0.343	5.23
x5/16	52.2	0.346	4.35	44.2	0.409	3.68	63.0	0.287	5.25
HSS20x8x5/8	48.3	0.627	4.03	36.3	0.834	3.03	54.0	0.561	4.50
x1/2	48.3	0.510	4.03	36.3	0.679	3.03	54.4	0.453	4.53
x3/8	48.2	0.389	4.02	36.2	0.518	3.02	54.8	0.342	4.57
x5/16	48.2	0.327	4.02	36.2	0.435	3.02	55.0	0.286	4.58
HSS20x4x1/2	44.3	0.472	3.69	28.3	0.739	2.36	46.4	0.450	3.87
x3/8	44.2	0.361	3.68	28.2	0.566	2.35	46.8	0.341	3.90
x5/16	44.2	0.304	3.68	28.2	0.476	2.35	47.0	0.285	3.92
HSS18x12x5/8	48.3	0.675	4.03	42.3	0.771	3.53	58.0	0.563	4.83
x1/2	48.3	0.549	4.03	42.3	0.627	3.53	58.4	0.453	4.87
x3/8	48.2	0.418	4.02	42.2	0.477	3.52	58.8	0.342	4.90
HSS18x6x5/8	42.3	0.606	3.53	30.3	0.846	2.53	46.0	0.558	3.83
x1/2	42.3	0.494	3.53	30.3	0.691	2.53	46.4	0.450	3.87
x3/8	42.2	0.378	3.52	30.2	0.528	2.52	46.8	0.341	3.90
x5/16	42.2	0.318	3.52	30.2	0.445	2.52	47.0	0.285	3.92
x1/4	42.1	0.257	3.51	30.1	0.359	2.51	47.2	0.229	3.93
HSS16x16x5/8	48.3	0.723	4.03	48.3	0.723	4.03	62.0	0.564	5.17
x1/2	48.3	0.587	4.03	48.3	0.587	4.03	62.4	0.454	5.20
x3/8	48.2	0.447	4.02	48.2	0.447	4.02	62.8	0.343	5.23
x5/16	48.2	0.375	4.02	48.2	0.375	4.02	63.0	0.287	5.25
HSS16x12x5/8	44.3	0.684	3.69	40.3	0.752	3.36	54.0	0.561	4.50
x1/2	44.3	0.556	3.69	40.3	0.611	3.36	54.4	0.453	4.53
x3/8	44.2	0.424	3.68	40.2	0.466	3.35	54.8	0.342	4.57
x5/16	44.2	0.356	3.68	40.2	0.392	3.35	55.0	0.286	4.58

Case A: Shape perimeter, minus one short surface. Case B: Shape perimeter, minus one long surface. Case C: Shape perimeter.



**Table 6a (Continued)**

Surface and Box Perimeters, Surface Areas and Area-to-Perimeter Ratios for Rectangular (and Square) Hollow Structural Sections

Shape	Case A (See Fig. 1, Pg. 89)			Case B (See Fig. 1, Pg. 89)			Case C (See Fig. 1, Pg. 89)		
	Peri- meter	A/P Ratio	Surf. Area	Peri- meter	A/P Ratio	Surf. Area	Peri- meter	A/P Ratio	Surf. Area
	in.		ft <sup>2</sup> /ft	in.		ft <sup>2</sup> /ft	in.		ft <sup>2</sup> /ft
HSS16x8x5/8	40.3	0.636	3.36	32.3	0.794	2.69	46.0	0.558	3.83
x1/2	40.3	0.519	3.36	32.3	0.648	2.69	46.4	0.450	3.87
x3/8	40.2	0.397	3.35	32.2	0.495	2.68	46.8	0.341	3.90
x5/16	40.2	0.334	3.35	32.2	0.417	2.68	47.0	0.285	3.92
HSS16x4x1/2	36.3	0.474	3.03	24.3	0.708	2.03	38.4	0.447	3.20
x3/8	36.2	0.364	3.02	24.2	0.544	2.02	38.8	0.339	3.23
x5/16	36.2	0.306	3.02	24.2	0.459	2.02	39.0	0.284	3.25
HSS14x14x5/8	42.3	0.716	3.53	42.3	0.716	3.53	54.0	0.561	4.50
x1/2	42.3	0.582	3.53	42.3	0.582	3.53	54.4	0.453	4.53
x3/8	42.2	0.444	3.52	42.2	0.444	3.52	54.8	0.342	4.57
x5/16	42.2	0.373	3.52	42.2	0.373	3.52	55.0	0.286	4.58
HSS14x12x1/2	40.3	0.565	3.36	38.3	0.595	3.19	50.4	0.452	4.20
x3/8	40.2	0.432	3.35	38.2	0.454	3.18	50.8	0.341	4.23
HSS14x10x5/8	38.3	0.670	3.19	34.3	0.748	2.86	46.0	0.558	3.83
x1/2	38.3	0.546	3.19	34.3	0.610	2.86	46.4	0.450	3.87
x3/8	38.2	0.418	3.18	34.2	0.466	2.85	46.8	0.341	3.90
x5/16	38.2	0.351	3.18	34.2	0.393	2.85	47.0	0.285	3.92
x1/4	38.1	0.284	3.18	34.1	0.317	2.84	47.2	0.229	3.93
HSS14x6x5/8	34.3	0.612	2.86	26.3	0.798	2.19	38.0	0.553	3.17
x1/2	34.3	0.501	2.86	26.3	0.654	2.19	38.4	0.447	3.20
x3/8	34.2	0.385	2.85	26.2	0.502	2.18	38.8	0.339	3.23
x5/16	34.2	0.324	2.85	26.2	0.424	2.18	39.0	0.284	3.25
x1/4	34.1	0.263	2.84	26.1	0.343	2.18	39.2	0.229	3.27
x3/16	34.1	0.198	2.84	26.1	0.259	2.18	39.4	0.172	3.28
HSS14x4x5/8	32.3	0.578	2.69	22.3	0.837	1.86	34.0	0.550	2.83
x1/2	32.3	0.475	2.69	22.3	0.688	1.86	34.4	0.445	2.87
x3/8	32.2	0.365	2.68	22.2	0.530	1.85	34.8	0.338	2.90
x5/16	32.2	0.308	2.68	22.2	0.448	1.85	35.0	0.283	2.92
x1/4	32.1	0.250	2.68	22.1	0.363	1.84	35.2	0.228	2.93
x3/16	32.1	0.189	2.68	22.1	0.274	1.84	35.4	0.171	2.95

Case A: Shape perimeter, minus one short surface.

Case C: Shape perimeter.

Case B: Shape perimeter, minus one long surface.

**Table 6a (Continued)**

Surface and Box Perimeters, Surface Areas and Area-to-Perimeter Ratios for Rectangular (and Square) Hollow Structural Sections

Shape	Case A (See Fig. 1, Pg. 89)			Case B (See Fig. 1, Pg. 89)			Case C (See Fig. 1, Pg. 89)		
	Peri- meter	A/P Ratio	Surf. Area	Peri- meter	A/P Ratio	Surf. Area	Peri- meter	A/P Ratio	Surf. Area
	in.		ft <sup>2</sup> /ft	in.		ft <sup>2</sup> /ft	in.		ft <sup>2</sup> /ft
HSS12x12x5/8	36.3	0.707	3.03	36.3	0.707	3.03	46.0	0.558	3.83
x1/2	36.3	0.576	3.03	36.3	0.576	3.03	46.4	0.450	3.87
x3/8	36.2	0.441	3.02	36.2	0.441	3.02	46.8	0.341	3.90
x5/16	36.2	0.371	3.02	36.2	0.371	3.02	47.0	0.285	3.92
x1/4	36.1	0.300	3.01	36.1	0.300	3.01	47.2	0.229	3.93
HSS12x10x1/2	34.3	0.556	2.86	32.3	0.590	2.69	42.4	0.449	3.53
x3/8	34.2	0.426	2.85	32.2	0.452	2.68	42.8	0.340	3.57
x5/16	34.2	0.358	2.85	32.2	0.381	2.68	43.0	0.285	3.58
x1/4	34.1	0.290	2.84	32.1	0.308	2.68	43.2	0.229	3.60
HSS12x8x5/8	32.3	0.650	2.69	28.3	0.742	2.36	38.0	0.553	3.17
x1/2	32.3	0.532	2.69	28.3	0.608	2.36	38.4	0.447	3.20
x3/8	32.2	0.409	2.68	28.2	0.467	2.35	38.8	0.339	3.23
x5/16	32.2	0.345	2.68	28.2	0.394	2.35	39.0	0.284	3.25
x1/4	32.1	0.279	2.68	28.1	0.319	2.34	39.2	0.229	3.27
x3/16	32.1	0.211	2.68	28.1	0.241	2.34	39.4	0.172	3.28
HSS12x6x5/8	30.3	0.616	2.53	24.3	0.768	2.03	34.0	0.550	2.83
x1/2	30.3	0.506	2.53	24.3	0.631	2.03	34.4	0.445	2.87
x3/8	30.2	0.390	2.52	24.2	0.486	2.02	34.8	0.338	2.90
x5/16	30.2	0.329	2.52	24.2	0.410	2.02	35.0	0.283	2.92
x1/4	30.1	0.267	2.51	24.1	0.333	2.01	35.2	0.228	2.93
x3/16	30.1	0.202	2.51	24.1	0.252	2.01	35.4	0.171	2.95
HSS12x4x5/8	28.3	0.578	2.36	20.3	0.805	1.69	30.0	0.546	2.50
x1/2	28.3	0.476	2.36	20.3	0.664	1.69	30.4	0.443	2.53
x3/8	28.2	0.368	2.35	20.2	0.513	1.68	30.8	0.337	2.57
x5/16	28.2	0.311	2.35	20.2	0.434	1.68	31.0	0.282	2.58
x1/4	28.1	0.252	2.34	20.1	0.353	1.68	31.2	0.228	2.60
x3/16	28.1	0.191	2.34	20.1	0.267	1.68	31.4	0.171	2.62
HSS12x3-1/2x3/8	27.7	0.362	2.31	19.2	0.522	1.60	29.8	0.336	2.48
x5/16	27.7	0.306	2.31	19.2	0.442	1.60	30.0	0.282	2.50

Case A: Shape perimeter, minus one short surface.

Case C: Shape perimeter.

Case B: Shape perimeter, minus one long surface.





**Table 6a (Continued)**

Surface and Box Perimeters, Surface Areas and Area-to-Perimeter Ratios for Rectangular (and Square) Hollow Structural Sections

Shape	Case A (See Fig. 1, Pg. 89)			Case B (See Fig. 1, Pg. 89)			Case C (See Fig. 1, Pg. 89)		
	Peri- meter	A/P Ratio	Surf. Area	Peri- meter	A/P Ratio	Surf. Area	Peri- meter	A/P Ratio	Surf. Area
	in.		ft <sup>2</sup> /ft	in.		ft <sup>2</sup> /ft	in.		ft <sup>2</sup> /ft
HSS10x4x5/8	24.3	0.577	2.03	18.3	0.766	1.53	26.0	0.540	2.17
x1/2	24.3	0.478	2.03	18.3	0.635	1.53	26.4	0.439	2.20
x3/8	24.2	0.371	2.02	18.2	0.493	1.52	26.8	0.335	2.23
x5/16	24.2	0.314	2.02	18.2	0.418	1.52	27.0	0.281	2.25
x1/4	24.1	0.256	2.01	18.1	0.340	1.51	27.2	0.227	2.27
x3/16	24.1	0.194	2.01	18.1	0.258	1.51	27.4	0.171	2.28
HSS10x3-1/2x3/16	23.6	0.191	1.97	17.1	0.263	1.43	26.4	0.170	2.20
HSS10x3x3/8	23.2	0.357	1.93	16.2	0.511	1.35	24.8	0.334	2.07
x5/16	23.2	0.303	1.93	16.2	0.434	1.35	25.0	0.280	2.08
x1/4	23.1	0.246	1.93	16.1	0.353	1.34	25.2	0.226	2.10
x3/16	23.1	0.187	1.93	16.1	0.269	1.34	25.4	0.170	2.12
x1/8	23.1	0.127	1.93	16.1	0.182	1.34	25.6	0.114	2.13
HSS10x2x3/8	22.2	0.341	1.85	14.2	0.534	1.18	22.8	0.332	1.90
x5/16	22.2	0.290	1.85	14.2	0.454	1.18	23.0	0.279	1.92
x1/4	22.1	0.237	1.84	14.1	0.370	1.18	23.2	0.226	1.93
x3/16	22.1	0.180	1.84	14.1	0.282	1.18	23.4	0.170	1.95
HSS9x7x5/8	25.3	0.646	2.11	23.3	0.702	1.94	30.0	0.546	2.50
x1/2	25.3	0.533	2.11	23.3	0.579	1.94	30.4	0.443	2.53
x3/8	25.2	0.411	2.10	23.2	0.447	1.93	30.8	0.337	2.57
x5/16	25.2	0.348	2.10	23.2	0.378	1.93	31.0	0.282	2.58
x1/4	25.1	0.282	2.09	23.1	0.307	1.93	31.2	0.228	2.60
x3/16	25.1	0.214	2.09	23.1	0.232	1.93	31.4	0.171	2.62
HSS9x5x5/8	23.3	0.602	1.94	19.3	0.727	1.61	26.0	0.540	2.17
x1/2	23.3	0.499	1.94	19.3	0.602	1.61	26.4	0.439	2.20
x3/8	23.2	0.387	1.93	19.2	0.467	1.60	26.8	0.335	2.23
x5/16	23.2	0.328	1.93	19.2	0.396	1.60	27.0	0.281	2.25
x1/4	23.1	0.267	1.93	19.1	0.322	1.59	27.2	0.227	2.27
x3/16	23.1	0.202	1.93	19.1	0.245	1.59	27.4	0.171	2.28

Case A: Shape perimeter, minus one short surface.

Case C: Shape perimeter.

Case B: Shape perimeter, minus one long surface.



**Table 6a (Continued)**

Surface and Box Perimeters, Surface Areas and Area-to-Perimeter Ratios for Rectangular (and Square) Hollow Structural Sections

Shape	Case A (See Fig. 1, Pg. 89)			Case B (See Fig. 1, Pg. 89)			Case C (See Fig. 1, Pg. 89)		
	Peri- meter	A/P Ratio	Surf. Area	Peri- meter	A/P Ratio	Surf. Area	Peri- meter	A/P Ratio	Surf. Area
	in.		ft <sup>2</sup> /ft	in.		ft <sup>2</sup> /ft	in.		ft <sup>2</sup> /ft
HSS9x3x1/2	21.3	0.458	1.78	15.3	0.638	1.28	22.4	0.435	1.87
x3/8	21.2	0.357	1.77	15.2	0.498	1.27	22.8	0.332	1.90
x5/16	21.2	0.304	1.77	15.2	0.424	1.27	23.0	0.279	1.92
x1/4	21.1	0.248	1.76	15.1	0.346	1.26	23.2	0.226	1.93
x3/16	21.1	0.188	1.76	15.1	0.263	1.26	23.4	0.170	1.95
HSS8x8x5/8	24.3	0.673	2.03	24.3	0.673	2.03	30.0	0.546	2.50
x1/2	24.3	0.555	2.03	24.3	0.555	2.03	30.4	0.443	2.53
x3/8	24.2	0.428	2.02	24.2	0.428	2.02	30.8	0.337	2.57
x5/16	24.2	0.362	2.02	24.2	0.362	2.02	31.0	0.282	2.58
x1/4	24.1	0.294	2.01	24.1	0.294	2.01	31.2	0.228	2.60
x3/16	24.1	0.223	2.01	24.1	0.223	2.01	31.4	0.171	2.62
HSS8x6x5/8	22.3	0.629	1.86	20.3	0.691	1.69	26.0	0.540	2.17
x1/2	22.3	0.521	1.86	20.3	0.572	1.69	26.4	0.439	2.20
x3/8	22.2	0.404	1.85	20.2	0.444	1.68	26.8	0.335	2.23
x5/16	22.2	0.342	1.85	20.2	0.376	1.68	27.0	0.281	2.25
x1/4	22.1	0.279	1.84	20.1	0.306	1.68	27.2	0.227	2.27
x3/16	22.1	0.211	1.84	20.1	0.233	1.68	27.4	0.171	2.28
HSS8x4x5/8	20.3	0.577	1.69	16.3	0.718	1.36	22.0	0.533	1.83
x1/2	20.3	0.481	1.69	16.3	0.599	1.36	22.4	0.435	1.87
x3/8	20.2	0.375	1.68	16.2	0.468	1.35	22.8	0.332	1.90
x5/16	20.2	0.319	1.68	16.2	0.398	1.35	23.0	0.279	1.92
x1/4	20.1	0.260	1.68	16.1	0.325	1.34	23.2	0.226	1.93
x3/16	20.1	0.198	1.68	16.1	0.247	1.34	23.4	0.170	1.95
x1/8	20.1	0.134	1.68	16.1	0.168	1.34	23.6	0.114	1.97
HSS8x3x1/2	19.3	0.457	1.61	14.3	0.618	1.19	20.4	0.432	1.70
x3/8	19.2	0.358	1.60	14.2	0.484	1.18	20.8	0.331	1.73
x5/16	19.2	0.305	1.60	14.2	0.413	1.18	21.0	0.278	1.75
x1/4	19.1	0.249	1.59	14.1	0.337	1.18	21.2	0.225	1.77
x3/16	19.1	0.190	1.59	14.1	0.257	1.18	21.4	0.170	1.78
x1/8	19.1	0.129	1.59	14.1	0.175	1.18	21.6	0.114	1.80

Case A: Shape perimeter, minus one short surface. Case B: Shape perimeter, minus one long surface. Case C: Shape perimeter.





**Table 6a (Continued)**

Surface and Box Perimeters, Surface Areas and Area-to-Perimeter Ratios for Rectangular (and Square) Hollow Structural Sections

Shape	Case A (See Fig. 1, Pg. 89)			Case B (See Fig. 1, Pg. 89)			Case C (See Fig. 1, Pg. 89)		
	Peri- meter	A/P Ratio	Surf. Area	Peri- meter	A/P Ratio	Surf. Area	Peri- meter	A/P Ratio	Surf. Area
	in.		ft <sup>2</sup> /ft	in.		ft <sup>2</sup> /ft	in.		ft <sup>2</sup> /ft
HSS8x2x3/8	18.2	0.340	1.52	12.2	0.507	1.02	18.8	0.329	1.57
x5/16	18.2	0.290	1.52	12.2	0.433	1.02	19.0	0.277	1.58
x1/4	18.1	0.237	1.51	12.1	0.355	1.01	19.2	0.224	1.60
x3/16	18.1	0.181	1.51	12.1	0.271	1.01	19.4	0.169	1.62
x1/8	18.1	0.124	1.51	12.1	0.185	1.01	19.6	0.114	1.63
HSS7x7x5/8	21.3	0.659	1.78	21.3	0.659	1.78	26.0	0.540	2.17
x1/2	21.3	0.545	1.78	21.3	0.545	1.78	26.4	0.439	2.20
x3/8	21.2	0.423	1.77	21.2	0.423	1.77	26.8	0.335	2.23
x5/16	21.2	0.359	1.77	21.2	0.359	1.77	27.0	0.281	2.25
x1/4	21.1	0.292	1.76	21.1	0.292	1.76	27.2	0.227	2.27
x3/16	21.1	0.221	1.76	21.1	0.221	1.76	27.4	0.171	2.28
HSS7x5x5/8	19.3	0.607	1.61	17.3	0.677	1.44	22.0	0.533	1.83
x1/2	19.3	0.506	1.61	17.3	0.564	1.44	22.4	0.435	1.87
x3/8	19.2	0.395	1.60	17.2	0.440	1.43	22.8	0.332	1.90
x5/16	19.2	0.335	1.60	17.2	0.374	1.43	23.0	0.279	1.92
x1/4	19.1	0.274	1.59	17.1	0.306	1.43	23.2	0.226	1.93
x3/16	19.1	0.208	1.59	17.1	0.233	1.43	23.4	0.170	1.95
x1/8	19.1	0.141	1.59	17.1	0.158	1.43	23.6	0.114	1.97
HSS7x4x1/2	18.3	0.482	1.53	15.3	0.577	1.28	20.4	0.432	1.70
x3/8	18.2	0.378	1.52	15.2	0.453	1.27	20.8	0.331	1.73
x5/16	18.2	0.322	1.52	15.2	0.385	1.27	21.0	0.278	1.75
x1/4	18.1	0.263	1.51	15.1	0.315	1.26	21.2	0.225	1.77
x3/16	18.1	0.201	1.51	15.1	0.240	1.26	21.4	0.170	1.78
x1/8	18.1	0.136	1.51	15.1	0.164	1.26	21.6	0.114	1.80
HSS7x3x1/2	17.3	0.456	1.44	13.3	0.594	1.11	18.4	0.428	1.53
x3/8	17.2	0.359	1.43	13.2	0.468	1.10	18.8	0.329	1.57
x5/16	17.2	0.307	1.43	13.2	0.400	1.10	19.0	0.277	1.58
x1/4	17.1	0.251	1.43	13.1	0.328	1.09	19.2	0.224	1.60
x3/16	17.1	0.192	1.43	13.1	0.250	1.09	19.4	0.169	1.62
x1/8	17.1	0.131	1.43	13.1	0.171	1.09	19.6	0.114	1.63
Case A: Shape perimeter, minus one short surface.				Case C: Shape perimeter.					
Case B: Shape perimeter, minus one long surface.									



**Table 6a (Continued)**

Surface and Box Perimeters, Surface Areas and Area-to-Perimeter Ratios for Rectangular (and Square) Hollow Structural Sections

Shape	Case A (See Fig. 1, Pg. 89)			Case B (See Fig. 1, Pg. 89)			Case C (See Fig. 1, Pg. 89)		
	Peri- meter	A/P Ratio	Surf. Area	Peri- meter	A/P Ratio	Surf. Area	Peri- meter	A/P Ratio	Surf. Area
	in.		ft <sup>2</sup> /ft	in.		ft <sup>2</sup> /ft	in.		ft <sup>2</sup> /ft
HSS6x6x5/8	18.3	0.640	1.53	18.3	0.640	1.53	22.0	0.533	1.83
x1/2	18.3	0.533	1.53	18.3	0.533	1.53	22.4	0.435	1.87
x3/8	18.2	0.416	1.52	18.2	0.416	1.52	22.8	0.332	1.90
x5/16	18.2	0.354	1.52	18.2	0.354	1.52	23.0	0.279	1.92
x1/4	18.1	0.289	1.51	18.1	0.289	1.51	23.2	0.226	1.93
x3/16	18.1	0.220	1.51	18.1	0.220	1.51	23.4	0.170	1.95
x1/8	18.1	0.149	1.51	18.1	0.149	1.51	23.6	0.114	1.97
HSS6x5x3/8	17.2	0.400	1.43	16.2	0.425	1.35	20.8	0.331	1.73
x5/16	17.2	0.341	1.43	16.2	0.362	1.35	21.0	0.278	1.75
x1/4	17.1	0.278	1.43	16.1	0.296	1.34	21.2	0.225	1.77
x3/16	17.1	0.212	1.43	16.1	0.225	1.34	21.4	0.170	1.78
HSS6x4x1/2	16.3	0.484	1.36	14.3	0.552	1.19	18.4	0.428	1.53
x3/8	16.2	0.381	1.35	14.2	0.435	1.18	18.8	0.329	1.57
x5/16	16.2	0.326	1.35	14.2	0.372	1.18	19.0	0.277	1.58
x1/4	16.1	0.267	1.34	14.1	0.304	1.18	19.2	0.224	1.60
x3/16	16.1	0.204	1.34	14.1	0.233	1.18	19.4	0.169	1.62
x1/8	16.1	0.139	1.34	14.1	0.159	1.18	19.6	0.114	1.63
HSS6x3x1/2	15.3	0.455	1.28	12.3	0.567	1.03	16.4	0.424	1.37
x3/8	15.2	0.361	1.27	12.2	0.449	1.02	16.8	0.326	1.40
x5/16	15.2	0.309	1.27	12.2	0.385	1.02	17.0	0.275	1.42
x1/4	15.1	0.254	1.26	12.1	0.316	1.01	17.2	0.223	1.43
x3/16	15.1	0.194	1.26	12.1	0.242	1.01	17.4	0.169	1.45
x1/8	15.1	0.133	1.26	12.1	0.166	1.01	17.6	0.114	1.47
HSS6x2x3/8	14.2	0.337	1.18	10.2	0.469	0.850	14.8	0.323	1.23
x5/16	14.2	0.289	1.18	10.2	0.403	0.850	15.0	0.273	1.25
x1/4	14.1	0.239	1.18	10.1	0.333	0.842	15.2	0.222	1.27
x3/16	14.1	0.183	1.18	10.1	0.256	0.842	15.4	0.168	1.28
x1/8	14.1	0.126	1.18	10.1	0.176	0.842	15.6	0.113	1.30
Case A: Shape perimeter, minus one short surface.				Case C: Shape perimeter.					
Case B: Shape perimeter, minus one long surface.									

**Table 6a (Continued)**

Surface and Box Perimeters, Surface Areas and Area-to-Perimeter Ratios for Rectangular (and Square) Hollow Structural Sections

Shape	Case A (See Fig. 1, Pg. 89)			Case B (See Fig. 1, Pg. 89)			Case C (See Fig. 1, Pg. 89)		
	Peri- meter	A/P Ratio	Surf. Area	Peri- meter	A/P Ratio	Surf. Area	Peri- meter	A/P Ratio	Surf. Area
	in.		ft <sup>2</sup> /ft	in.		ft <sup>2</sup> /ft	in.		ft <sup>2</sup> /ft
HSS5-1/2x5-1/2x3/8	16.7	0.412	1.39	16.7	0.412	1.39	20.8	0.331	1.73
x5/16	16.7	0.351	1.39	16.7	0.351	1.39	21.0	0.278	1.75
x1/4	16.6	0.287	1.38	16.6	0.287	1.38	21.2	0.225	1.77
x3/16	16.6	0.219	1.38	16.6	0.219	1.38	21.4	0.170	1.78
x1/8	16.6	0.149	1.38	16.6	0.149	1.38	21.6	0.114	1.80
HSS5x5x1/2	15.3	0.516	1.28	15.3	0.516	1.28	18.4	0.428	1.53
x3/8	15.2	0.407	1.27	15.2	0.407	1.27	18.8	0.329	1.57
x5/16	15.2	0.347	1.27	15.2	0.347	1.27	19.0	0.277	1.58
x1/4	15.1	0.284	1.26	15.1	0.284	1.26	19.2	0.224	1.60
x3/16	15.1	0.217	1.26	15.1	0.217	1.26	19.4	0.169	1.62
x1/8	15.1	0.148	1.26	15.1	0.148	1.26	19.6	0.114	1.63
HSS5x4x1/2	14.3	0.487	1.19	13.3	0.524	1.11	16.4	0.424	1.37
x3/8	14.2	0.386	1.18	13.2	0.415	1.10	16.8	0.326	1.40
x5/16	14.2	0.330	1.18	13.2	0.356	1.10	17.0	0.275	1.42
x1/4	14.1	0.272	1.18	13.1	0.292	1.09	17.2	0.223	1.43
x3/16	14.1	0.208	1.18	13.1	0.224	1.09	17.4	0.169	1.45
HSS5x3x1/2	13.3	0.454	1.11	11.3	0.534	0.942	14.4	0.418	1.20
x3/8	13.2	0.362	1.10	11.2	0.427	0.933	14.8	0.323	1.23
x5/16	13.2	0.311	1.10	11.2	0.367	0.933	15.0	0.273	1.25
x1/4	13.1	0.257	1.09	11.1	0.303	0.925	15.2	0.222	1.27
x3/16	13.1	0.197	1.09	11.1	0.233	0.925	15.4	0.168	1.28
x1/8	13.1	0.135	1.09	11.1	0.160	0.925	15.6	0.113	1.30
HSS5x2-1/2x1/4	12.6	0.248	1.05	10.1	0.310	0.842	14.2	0.221	1.18
x3/16	12.6	0.191	1.05	10.1	0.239	0.842	14.4	0.167	1.20
x1/8	12.6	0.131	1.05	10.1	0.164	0.842	14.6	0.113	1.22
HSS5x2x3/8	12.2	0.335	1.02	9.20	0.444	0.767	12.8	0.319	1.07
x5/16	12.2	0.289	1.02	9.16	0.384	0.763	13.0	0.271	1.08
x1/4	12.1	0.239	1.01	9.13	0.318	0.761	13.2	0.220	1.10
x3/16	12.1	0.185	1.01	9.10	0.246	0.758	13.4	0.167	1.12
x1/8	12.1	0.127	1.01	9.07	0.169	0.756	13.6	0.113	1.13

Case A: Shape perimeter, minus one short surface.

Case C: Shape perimeter.

Case B: Shape perimeter, minus one long surface.



**Table 6a (Continued)**

Surface and Box Perimeters, Surface Areas and Area-to-Perimeter Ratios for Rectangular (and Square) Hollow Structural Sections

Shape	Case A (See Fig. 1, Pg. 89)			Case B (See Fig. 1, Pg. 89)			Case C (See Fig. 1, Pg. 89)		
	Peri- meter	A/P Ratio	Surf. Area	Peri- meter	A/P Ratio	Surf. Area	Peri- meter	A/P Ratio	Surf. Area
	in.		ft <sup>2</sup> /ft	in.		ft <sup>2</sup> /ft	in.		ft <sup>2</sup> /ft
HSS4-1/2x4-1/2x1/2	13.8	0.505	1.15	13.8	0.505	1.15	16.4	0.424	1.37
x3/8	13.7	0.400	1.14	13.7	0.400	1.14	16.8	0.326	1.40
x5/16	13.7	0.343	1.14	13.7	0.343	1.14	17.0	0.275	1.42
x1/4	13.6	0.281	1.13	13.6	0.281	1.13	17.2	0.223	1.43
x3/16	13.6	0.216	1.13	13.6	0.216	1.13	17.4	0.169	1.45
x1/8	13.6	0.147	1.13	13.6	0.147	1.13	17.6	0.114	1.47
HSS4x4x1/2	12.3	0.491	1.03	12.3	0.491	1.03	14.4	0.418	1.20
x3/8	12.2	0.392	1.02	12.2	0.392	1.02	14.8	0.323	1.23
x5/16	12.2	0.337	1.02	12.2	0.337	1.02	15.0	0.273	1.25
x1/4	12.1	0.278	1.01	12.1	0.278	1.01	15.2	0.222	1.27
x3/16	12.1	0.214	1.01	12.1	0.214	1.01	15.4	0.168	1.28
x1/8	12.1	0.146	1.01	12.1	0.146	1.01	15.6	0.113	1.30
HSS4x3x3/8	11.2	0.365	0.933	10.2	0.401	0.850	12.8	0.319	1.07
x5/16	11.2	0.315	0.933	10.2	0.346	0.850	13.0	0.271	1.08
x1/4	11.1	0.261	0.925	10.1	0.287	0.842	13.2	0.220	1.10
x3/16	11.1	0.202	0.925	10.1	0.222	0.842	13.4	0.167	1.12
x1/8	11.1	0.139	0.925	10.1	0.153	0.842	13.6	0.113	1.13
HSS4x2-1/2x5/16	10.7	0.303	0.892	9.16	0.352	0.763	12.0	0.269	1.00
x1/4	10.6	0.251	0.883	9.13	0.293	0.761	12.2	0.219	1.02
x3/16	10.6	0.195	0.883	9.10	0.227	0.758	12.4	0.166	1.03
HSS4x2x3/8	10.2	0.332	0.850	8.20	0.413	0.683	10.8	0.314	0.900
x5/16	10.2	0.289	0.850	8.16	0.359	0.680	11.0	0.267	0.917
x1/4	10.1	0.241	0.842	8.13	0.300	0.678	11.2	0.218	0.933
x3/16	10.1	0.187	0.842	8.10	0.233	0.675	11.4	0.166	0.950
x1/8	10.1	0.130	0.842	8.07	0.162	0.673	11.6	0.112	0.967
HSS3-1/2x3-1/2x3/8	10.7	0.382	0.892	10.7	0.382	0.892	12.8	0.319	1.07
x5/16	10.7	0.330	0.892	10.7	0.330	0.892	13.0	0.271	1.08
x1/4	10.6	0.273	0.883	10.6	0.273	0.883	13.2	0.220	1.10
x3/16	10.6	0.211	0.883	10.6	0.211	0.883	13.4	0.167	1.12
x1/8	10.6	0.145	0.883	10.6	0.145	0.883	13.6	0.113	1.13

Case A: Shape perimeter, minus one short surface.

Case C: Shape perimeter.

Case B: Shape perimeter, minus one long surface.



**Table 6a (Continued)**

Surface and Box Perimeters, Surface Areas and Area-to-Perimeter Ratios for Rectangular (and Square) Hollow Structural Sections

Shape	Case A (See Fig. 1, Pg. 89)			Case B (See Fig. 1, Pg. 89)			Case C (See Fig. 1, Pg. 89)		
	Peri- meter	A/P Ratio	Surf. Area	Peri- meter	A/P Ratio	Surf. Area	Peri- meter	A/P Ratio	Surf. Area
	in.		ft <sup>2</sup> /ft	in.		ft <sup>2</sup> /ft	in.		ft <sup>2</sup> /ft
HSS3-1/2x2-1/2x3/8	9.70	0.349	0.808	8.70	0.389	0.725	10.8	0.314	0.900
x5/16	9.66	0.304	0.805	8.66	0.339	0.722	11.0	0.267	0.917
x1/4	9.63	0.253	0.803	8.63	0.283	0.719	11.2	0.218	0.933
x3/16	9.60	0.197	0.800	8.60	0.220	0.717	11.4	0.166	0.950
x1/8	9.57	0.136	0.798	8.57	0.152	0.714	11.6	0.112	0.967
HSS3x3x3/8	9.20	0.368	0.767	9.20	0.368	0.767	10.8	0.314	0.900
x5/16	9.16	0.320	0.763	9.16	0.320	0.763	11.0	0.267	0.917
x1/4	9.13	0.267	0.761	9.13	0.267	0.761	11.2	0.218	0.933
x3/16	9.10	0.208	0.758	9.10	0.208	0.758	11.4	0.166	0.950
x1/8	9.07	0.144	0.756	9.07	0.144	0.756	11.6	0.112	0.967
HSS3x2-1/2x5/16	8.66	0.305	0.722	8.16	0.324	0.680	10.0	0.264	0.833
x1/4	8.63	0.256	0.719	8.13	0.271	0.678	10.2	0.216	0.850
x3/16	8.60	0.199	0.717	8.10	0.212	0.675	10.4	0.165	0.867
x1/8	8.57	0.139	0.714	8.07	0.147	0.673	10.6	0.112	0.883
HSS3x2x5/16	8.16	0.288	0.680	7.16	0.328	0.597	9.00	0.261	0.750
x1/4	8.13	0.243	0.678	7.13	0.277	0.594	9.20	0.214	0.767
x3/16	8.10	0.190	0.675	7.10	0.217	0.592	9.40	0.164	0.783
x1/8	8.07	0.133	0.673	7.07	0.152	0.589	9.60	0.112	0.800
HSS3x1-1/2x1/4	7.63	0.228	0.636	6.13	0.284	0.511	8.20	0.212	0.683
x3/16	7.60	0.180	0.633	6.10	0.224	0.508	8.40	0.163	0.700
x1/8	7.57	0.126	0.631	6.07	0.158	0.506	8.60	0.111	0.717
HSS3x1x1/8	7.07	0.119	0.589	5.07	0.166	0.423	7.60	0.110	0.633
HSS2-1/2x2-1/2x5/16	7.66	0.31	0.638	7.66	0.307	0.638	9.00	0.261	0.750
x1/4	7.63	0.259	0.636	7.63	0.259	0.636	9.20	0.214	0.767
x3/16	7.60	0.203	0.633	7.60	0.203	0.633	9.40	0.164	0.783
x1/8	7.57	0.142	0.631	7.57	0.142	0.631	9.60	0.112	0.800
HSS2-1/2x1-1/2x1/4	6.63	0.227	0.553	5.63	0.268	0.469	7.20	0.209	0.600
x3/16	6.60	0.181	0.550	5.60	0.213	0.467	7.40	0.161	0.617
x1/8	6.57	0.128	0.548	5.57	0.151	0.464	7.60	0.110	0.633

Case A: Shape perimeter, minus one short surface. Case C: Shape perimeter.  
Case B: Shape perimeter, minus one long surface.



**Table 6a (Continued)**

Surface and Box Perimeters, Surface Areas and Area-to-Perimeter Ratios for Rectangular (and Square) Hollow Structural Sections

Shape	Case A (See Fig. 1, Pg. 89)			Case B (See Fig. 1, Pg. 89)			Case C (See Fig. 1, Pg. 89)		
	Peri- meter	A/P Ratio	Surf. Area	Peri- meter	A/P Ratio	Surf. Area	Peri- meter	A/P Ratio	Surf. Area
	in.		ft <sup>2</sup> /ft	in.		ft <sup>2</sup> /ft	in.		ft <sup>2</sup> /ft
HSS2-1/4x2-1/4x1/4	6.13	0.253	0.511	6.13	0.253	0.511	7.20	0.212	0.600
x3/16	6.85	0.200	0.571	6.85	0.200	0.571	8.40	0.163	0.700
x1/8	6.82	0.140	0.568	6.82	0.140	0.568	8.60	0.111	0.717
HSS2x2x1/4	6.13	0.246	0.511	6.13	0.246	0.511	7.20	0.209	0.600
x3/16	6.10	0.196	0.508	6.10	0.196	0.508	7.40	0.161	0.617
x1/8	6.07	0.138	0.506	6.07	0.138	0.506	7.60	0.110	0.633
HSS2x1-1/2x3/16	5.60	0.182	0.467	5.10	0.200	0.425	6.40	0.159	0.533
HSS2x1x3/16	5.10	0.166	0.425	4.10	0.206	0.342	5.40	0.156	0.450
x1/8	5.07	0.120	0.423	4.07	0.149	0.339	5.60	0.108	0.467
HSS1-3/4x1-3/4x3/16	5.35	0.191	0.446	5.35	0.191	0.446	6.40	0.159	0.533
HSS1-5/8x1-5/8x3/16	4.97	0.187	0.414	4.97	0.187	0.414	5.90	0.158	0.492
x1/8	4.94	0.135	0.412	4.94	0.135	0.412	6.10	0.109	0.508
HSS1-1/2x1-1/2x3/16	4.60	0.184	0.383	4.60	0.184	0.383	5.40	0.156	0.450
x1/8	4.57	0.133	0.381	4.57	0.133	0.381	5.60	0.108	0.467
HSS1-1/4x1-1/4x3/16	3.85	0.174	0.321	3.85	0.174	0.321	4.40	0.152	0.367
x1/8	3.82	0.129	0.318	3.82	0.129	0.318	4.60	0.107	0.383
Case A: Shape perimeter, minus one short surface.			Case C: Shape perimeter.						
Case B: Shape perimeter, minus one long surface.									

**Table 6b**

Surface and Box Perimeters, Surface Areas and Area-to-Perimeter Ratios for Round Hollow Structural Sections

Shape	Case A (See Fig. 1, Pg. 89)			Case B (See Fig. 1, Pg. 89)		
	Perimeter	A/P Ratio	Surf. Area	Perimeter	A/P Ratio	Surf. Area
	in.		ft <sup>2</sup> /ft	in.		ft <sup>2</sup> /ft
HSS20.000x0.500	62.8	0.454	5.23	80.0	0.357	6.67
x0.375	62.8	0.343	5.23	80.0	0.269	6.67
HSS18.000x0.500	56.5	0.453	4.71	72.0	0.356	6.00
x0.375	56.5	0.342	4.71	72.0	0.269	6.00
HSS16.000x0.500	50.3	0.451	4.19	64.0	0.355	5.33
x0.438	50.3	0.397	4.19	64.0	0.312	5.33
x0.375	50.3	0.341	4.19	64.0	0.268	5.33
x0.312	50.3	0.286	4.19	64.0	0.224	5.33
HSS14.000x0.500	44.0	0.450	3.67	56.0	0.353	4.67
x0.375	44.0	0.340	3.67	56.0	0.267	4.67
x0.312	44.0	0.285	3.67	56.0	0.224	4.67
HSS12.750x0.500	40.1	0.448	3.34	51.0	0.352	4.25
x0.375	40.1	0.339	3.34	51.0	0.267	4.25
x0.250	40.1	0.229	3.34	51.0	0.180	4.25
HSS12.500x0.625	39.3	0.554	3.28	50.0	0.435	4.17
x0.500	39.3	0.448	3.28	50.0	0.352	4.17
x0.375	39.3	0.339	3.28	50.0	0.266	4.17
x0.312	39.3	0.284	3.28	50.0	0.223	4.17
x0.250	39.3	0.229	3.28	50.0	0.180	4.17
x0.188	39.3	0.172	3.28	50.0	0.135	4.17
HSS11.250x0.625	35.3	0.551	2.94	45.0	0.433	3.75
x0.500	35.3	0.446	2.94	45.0	0.350	3.75
x0.375	35.3	0.338	2.94	45.0	0.266	3.75
x0.312	35.3	0.283	2.94	45.0	0.223	3.75
x0.250	35.3	0.228	2.94	45.0	0.179	3.75
x0.188	35.3	0.171	2.94	45.0	0.135	3.75
HSS10.750x0.500	33.8	0.445	2.82	43.0	0.349	3.58
x0.250	33.8	0.228	2.82	43.0	0.179	3.58
HSS10.000x0.625	31.4	0.547	2.62	40.0	0.430	3.33
x0.500	31.4	0.443	2.62	40.0	0.348	3.33
x0.375	31.4	0.337	2.62	40.0	0.265	3.33
x0.312	31.4	0.283	2.62	40.0	0.222	3.33
x0.250	31.4	0.228	2.62	40.0	0.179	3.33
x0.188	31.4	0.171	2.62	40.0	0.134	3.33

Case A: Shape perimeter.

Case B: Box perimeter, equal to four times the depth.



**Table 6b (Continued)**

Surface and Box Perimeters, Surface Areas and Area-to-Perimeter Ratios for Round Hollow Structural Sections

Shape	Case A (See Fig. 1, Pg. 89)			Case B (See Fig. 1, Pg. 89)		
	Perimeter	A/P Ratio	Surf. Area	Perimeter	A/P Ratio	Surf. Area
	In.		ft <sup>2</sup> /ft	In.		ft <sup>2</sup> /ft
HSS9.625x0.500	30.2	0.443	2.52	38.5	0.348	3.21
x0.375	30.2	0.336	2.52	38.5	0.264	3.21
x0.312	30.2	0.282	2.52	38.5	0.222	3.21
x0.250	30.2	0.227	2.52	38.5	0.179	3.21
x0.188	30.2	0.171	2.52	38.5	0.134	3.21
HSS8.750x0.500	27.5	0.440	2.29	35.0	0.346	2.92
x0.375	27.5	0.335	2.29	35.0	0.263	2.92
x0.312	27.5	0.281	2.29	35.0	0.221	2.92
x0.250	27.5	0.227	2.29	35.0	0.178	2.92
x0.188	27.5	0.171	2.29	35.0	0.134	2.92
HSS8.625x0.500	27.1	0.440	2.26	34.5	0.346	2.88
x0.375	27.1	0.335	2.26	34.5	0.263	2.88
x0.322	27.1	0.290	2.26	34.5	0.227	2.88
x0.250	27.1	0.227	2.26	34.5	0.178	2.88
x0.188	27.1	0.170	2.26	34.5	0.134	2.88
HSS7.625x0.125	24.0	0.114	2.00	30.5	0.090	2.54
HSS7.500x0.500	23.6	0.436	1.97	30.0	0.343	2.50
x0.375	23.6	0.333	1.97	30.0	0.261	2.50
x0.312	23.6	0.280	1.97	30.0	0.220	2.50
x0.250	23.6	0.226	1.97	30.0	0.177	2.50
x0.188	23.6	0.170	1.97	30.0	0.133	2.50
HSS7.000x0.500	22.0	0.434	1.83	28.0	0.341	2.33
x0.375	22.0	0.332	1.83	28.0	0.260	2.33
x0.312	22.0	0.279	1.83	28.0	0.219	2.33
x0.250	22.0	0.225	1.83	28.0	0.177	2.33
x0.188	22.0	0.170	1.83	28.0	0.133	2.33
x0.125	22.0	0.114	1.83	28.0	0.090	2.33
HSS6.875x0.500	21.6	0.434	1.80	27.5	0.341	2.29
x0.375	21.6	0.331	1.80	27.5	0.260	2.29
x0.312	21.6	0.279	1.80	27.5	0.219	2.29
x0.250	21.6	0.225	1.80	27.5	0.177	2.29
x0.188	21.6	0.170	1.80	27.5	0.133	2.29

Case A: Shape perimeter.

Case B: Box perimeter, equal to four times the depth.





**Table 6b (Continued)**

Surface and Box Perimeters, Surface Areas and Area-to-Perimeter Ratios for Round Hollow Structural Sections

Shape	Case A (See Fig. 1, Pg. 89)			Case B (See Fig. 1, Pg. 89)		
	Perimeter	A/P Ratio	Surf. Area	Perimeter	A/P Ratio	Surf. Area
	in.		ft <sup>2</sup> /ft	in.		ft <sup>2</sup> /ft
HSS6.625x0.500	20.8	0.432	1.73	26.5	0.340	2.21
x0.432	20.8	0.378	1.73	26.5	0.297	2.21
x0.375	20.8	0.331	1.73	26.5	0.260	2.21
x0.312	20.8	0.278	1.73	26.5	0.219	2.21
x0.280	20.8	0.251	1.73	26.5	0.197	2.21
x0.250	20.8	0.225	1.73	26.5	0.177	2.21
x0.188	20.8	0.169	1.73	26.5	0.133	2.21
x0.125	20.8	0.114	1.73	26.5	0.0895	2.21
HSS6.125x0.500	19.2	0.430	1.60	24.5	0.337	2.04
x0.375	19.2	0.329	1.60	24.5	0.258	2.04
x0.312	19.2	0.277	1.60	24.5	0.218	2.04
x0.250	19.2	0.224	1.60	24.5	0.176	2.04
x0.188	19.2	0.169	1.60	24.5	0.133	2.04
HSS6.000x0.500	18.8	0.429	1.57	24.0	0.337	2.00
x0.375	18.8	0.329	1.57	24.0	0.258	2.00
x0.312	18.8	0.277	1.57	24.0	0.217	2.00
x0.280	18.8	0.250	1.57	24.0	0.196	2.00
x0.250	18.8	0.224	1.57	24.0	0.176	2.00
x0.188	18.8	0.169	1.57	24.0	0.133	2.00
x0.125	18.8	0.114	1.57	24.0	0.0893	2.00
HSS5.563x0.375	17.5	0.327	1.46	22.3	0.257	1.86
x0.258	17.5	0.231	1.46	22.3	0.181	1.86
x0.188	17.5	0.169	1.46	22.3	0.132	1.86
x0.134	17.5	0.122	1.46	22.3	0.0960	1.86
HSS5.500x0.500	17.3	0.426	1.44	22.0	0.334	1.83
x0.375	17.3	0.327	1.44	22.0	0.257	1.83
x0.258	17.3	0.230	1.44	22.0	0.181	1.83
HSS5.000x0.500	15.7	0.422	1.31	20.0	0.331	1.67
x0.375	15.7	0.325	1.31	20.0	0.255	1.67
x0.312	15.7	0.274	1.31	20.0	0.215	1.67
x0.258	15.7	0.229	1.31	20.0	0.180	1.67
x0.250	15.7	0.222	1.31	20.0	0.174	1.67
x0.188	15.7	0.168	1.31	20.0	0.132	1.67
x0.125	15.7	0.113	1.31	20.0	0.0890	1.67
HSS4.500x0.337	14.1	0.293	1.18	18.0	0.230	1.50
x0.237	14.1	0.210	1.18	18.0	0.165	1.50
x0.188	14.1	0.167	1.18	18.0	0.131	1.50
x0.125	14.1	0.113	1.18	18.0	0.0888	1.50

Case A: Shape perimeter.

Case B: Box perimeter, equal to four times the depth.



**Table 6b (Continued)**

Surface and Box Perimeters, Surface Areas and Area-to-Perimeter Ratios for Round Hollow Structural Sections

Shape	Case A (See Fig. 1, Pg. 89)			Case B (See Fig. 1, Pg. 89)		
	Perimeter	A/P Ratio	Surf. Area	Perimeter	A/P Ratio	Surf. Area
	in.		ft <sup>2</sup> /ft	in.		ft <sup>2</sup> /ft
HSS4.000x0.337	12.6	0.290	1.05	16.0	0.228	1.33
x0.313	12.6	0.270	1.05	16.0	0.212	1.33
x0.250	12.6	0.219	1.05	16.0	0.172	1.33
x0.237	12.6	0.209	1.05	16.0	0.164	1.33
x0.226	12.6	0.200	1.05	16.0	0.157	1.33
x0.220	12.6	0.194	1.05	16.0	0.153	1.33
x0.188	12.6	0.166	1.05	16.0	0.131	1.33
x0.125	12.6	0.113	1.05	16.0	0.0885	1.33
HSS3.500x0.313	11.0	0.267	0.917	14.0	0.210	1.17
x0.300	11.0	0.258	0.917	14.0	0.202	1.17
x0.250	11.0	0.217	0.917	14.0	0.171	1.17
x0.216	11.0	0.189	0.917	14.0	0.149	1.17
x0.203	11.0	0.179	0.917	14.0	0.140	1.17
x0.188	11.0	0.165	0.917	14.0	0.130	1.17
x0.125	11.0	0.112	0.917	14.0	0.0881	1.17
HSS3.000x0.300	9.42	0.254	0.785	12.0	0.199	1.00
x0.250	9.42	0.215	0.785	12.0	0.169	1.00
x0.216	9.42	0.188	0.785	12.0	0.147	1.00
x0.203	9.42	0.177	0.785	12.0	0.139	1.00
x0.188	9.42	0.164	0.785	12.0	0.129	1.00
x0.152	9.42	0.135	0.785	12.0	0.106	1.00
x0.134	9.42	0.120	0.785	12.0	0.0941	1.00
x0.120	9.42	0.108	0.785	12.0	0.0847	1.00
HSS2.875x0.250	9.03	0.214	0.753	11.5	0.168	0.958
x0.203	9.03	0.177	0.753	11.5	0.139	0.958
x0.188	9.03	0.163	0.753	11.5	0.128	0.958
x0.125	9.03	0.111	0.753	11.5	0.0874	0.958
HSS2.500x0.250	7.85	0.211	0.654	10.0	0.166	0.833
x0.188	7.85	0.162	0.654	10.0	0.127	0.833
x0.125	7.85	0.111	0.654	10.0	0.0869	0.833
HSS2.375x0.250	7.46	0.210	0.622	9.50	0.165	0.792
x0.218	7.46	0.186	0.622	9.50	0.146	0.792
x0.188	7.46	0.161	0.622	9.50	0.127	0.792
x0.154	7.46	0.134	0.622	9.50	0.106	0.792
x0.125	7.46	0.110	0.622	9.50	0.0867	0.792
HSS1.900x0.145	5.97	0.125	0.498	7.60	0.0985	0.633
HSS1.660x0.140	5.22	0.120	0.435	6.64	0.0941	0.553

Case A: Shape perimeter.

Case B: Box perimeter, equal to four times the depth.

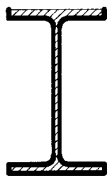
**Table 6c**

Surface and Box Perimeters, Surface Areas and Area-to-Perimeter Ratios for Pipes

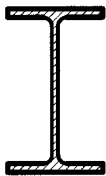
Shape	Case A (See Fig. 1, Pg. 89)			Case B (See Fig. 1, Pg. 89)		
	Perimeter	A/P Ratio	Surf. Area	Perimeter	A/P Ratio	Surf. Area
	in.		ft <sup>2</sup> /ft	in.		ft <sup>2</sup> /ft
<b>Standard Weight</b>						
12	40.1	0.364	3.34	51.0	0.286	4.25
10	33.8	0.353	2.81	43.0	0.277	3.58
8	27.1	0.310	2.26	34.5	0.243	2.88
6	20.8	0.268	1.73	26.5	0.211	2.21
5	17.5	0.246	1.46	22.3	0.193	1.85
4	14.1	0.225	1.18	18.0	0.176	1.50
3 1/2	12.6	0.213	1.05	16.0	0.167	1.33
3	11.0	0.203	0.916	14.0	0.159	1.17
2 1/2	9.03	0.189	0.753	11.5	0.148	0.958
2	7.46	0.144	0.622	9.50	0.113	0.792
1 1/2	5.97	0.134	0.497	7.60	0.105	0.633
1 1/4	5.22	0.128	0.435	6.64	0.101	0.553
1	4.13	0.120	0.344	5.26	0.0939	0.438
3/4	3.30	0.101	0.275	4.20	0.0792	0.350
1/2	2.64	0.0949	0.220	3.36	0.0745	0.280
<b>Extra Strong</b>						
12	40.1	0.480	3.34	51.0	0.377	4.25
10	33.8	0.477	2.81	43.0	0.374	3.58
8	27.1	0.471	2.26	34.5	0.370	2.88
6	20.8	0.404	1.73	26.5	0.317	2.21
5	17.5	0.350	1.46	22.3	0.275	1.85
4	14.1	0.312	1.18	18.0	0.245	1.50
3 1/2	12.6	0.293	1.05	16.0	0.230	1.33
3	11.0	0.274	0.916	14.0	0.215	1.17
2 1/2	9.03	0.250	0.753	11.5	0.196	0.958
2	7.46	0.198	0.622	9.50	0.156	0.792
1 1/2	5.97	0.179	0.497	7.60	0.141	0.633
1 1/4	5.22	0.169	0.435	6.64	0.133	0.553
1	4.13	0.155	0.344	5.26	0.121	0.438
3/4	3.30	0.131	0.275	4.20	0.103	0.350
1/2	2.64	0.121	0.220	3.36	0.0952	0.280
<b>Double-Extra Strong</b>						
8	27.1	0.786	2.26	34.5	0.618	2.88
6	20.8	0.751	1.73	26.5	0.590	2.21
5	17.5	0.649	1.46	22.3	0.510	1.85
4	14.1	0.573	1.18	18.0	0.450	1.50
3	11.0	0.497	0.916	14.0	0.390	1.17
2.5	9.03	0.446	0.753	11.5	0.350	0.958
2	7.46	0.356	0.622	9.50	0.280	0.792
Case A: Shape perimeter. Case B: Box perimeter, equal to four times the depth.						



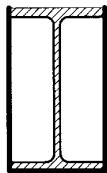
W- AND M-SHAPES



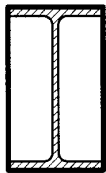
Case A



Case B

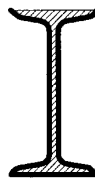


Case C

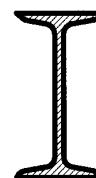


Case D

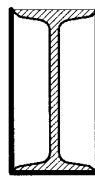
S-SHAPE



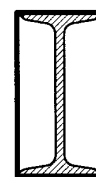
Case A



Case B

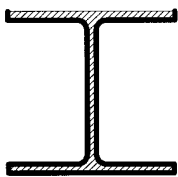


Case C

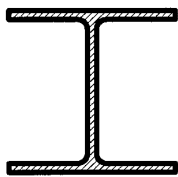


Case D

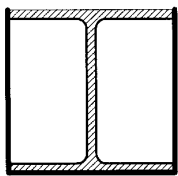
HP-SHAPES



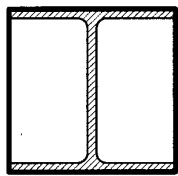
Case A



Case B

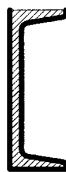


Case C

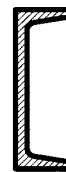


Case D

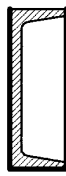
CHANNELS



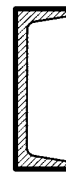
Case A



Case B



Case C

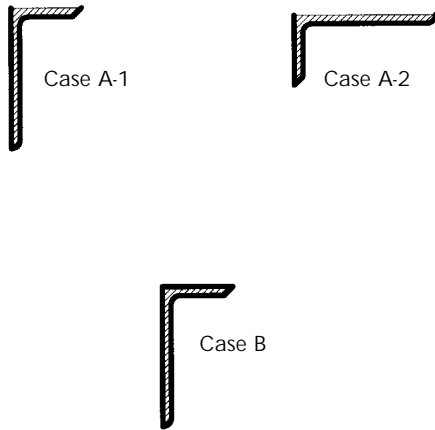


Case D

- Case A: Shape perimeter, minus one flange surface
- Case B: Shape perimeter
- Case C: Box perimeter, minus one flange surface
- Case D: Box perimeter

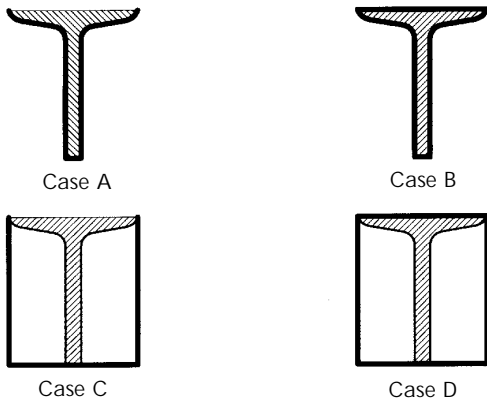
Figure 1. Shape and Box Perimeters

**ANGLES**



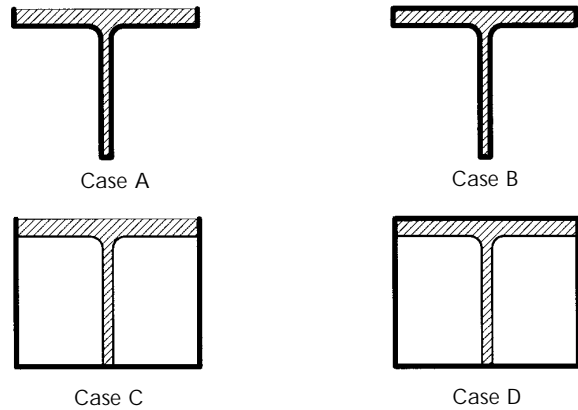
- Case A-1: Shape perimeter, minus short leg surface
- Case A-2: Shape perimeter, minus long leg surface
- Case B: Shape perimeter

**ST-SHAPES**



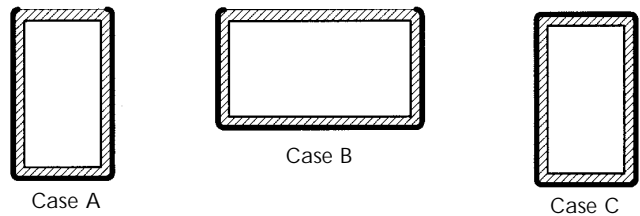
- Case A: Shape perimeter, minus one flange surface
- Case B: Shape perimeter
- Case C: Box perimeter, minus one flange surface
- Case D: Box perimeter

**WT- AND MT-SHAPES**



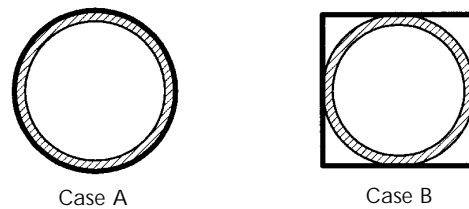
- Case A: Shape perimeter, minus one flange surface
- Case B: Shape perimeter
- Case C: Box perimeter, minus one flange surface
- Case D: Box perimeter

**RECTANGULAR (AND SQUARE) HSS**



- Case A: Shape perimeter, minus one short surface
- Case B: Shape perimeter, minus one long surface
- Case C: Shape perimeter

**ROUND HSS AND PIPES**



- Case A: Shape perimeter
- Case B: Shape perimeter, equal to four times the depth

**Figure 1. (Continued)** Shape and Box Perimeters





## CONTENTS OF DETAILS SECTION

INTRODUCTION .....	3
GENERAL CONSIDERATIONS .....	3
Lateral System .....	3
Floor System .....	3
Fireproofing .....	4
DETAILING CONSIDERATIONS FOR MASONRY .....	5
Enclosure System .....	5
Masonry Anchors .....	6
DETAILING CONSIDERATIONS FOR PRECAST CONCRETE PANELS .....	9
General Considerations .....	9
Gravity Load .....	9
Wind Load .....	9
Construction Tolerances .....	9
Connections .....	9
Inside Corners .....	9
DETAILING CONSIDERATIONS FOR LIMESTONE PANELS .....	14
Anchors .....	14
Back-up Systems .....	14
Supports .....	14
DETAILING CONSIDERATIONS FOR THIN STONE VENEER PANELS .....	15
General Design Considerations .....	15
Back-up System .....	15
Anchors .....	15
DETAILING CONSIDERATIONS FOR WINDOW WALL ENCLOSURE SYSTEMS .....	16
General Considerations .....	16
DETAILING CONSIDERATIONS FOR FLOOR/CEILING SANDWICH .....	17
M.E.P. Space .....	17
DESIGN CONSIDERATIONS FOR DIAGONAL BRACING DETAILS .....	18
General .....	18
Gusset Plates .....	18
Work Lines .....	18
Bracing Members .....	19
Work Point .....	19
ADDITIONAL REFERENCES .....	19



**LIST OF FIGURES**

Figure 1a. Detailing Considerations for Masonry (Plan Detail at Masonry Corner) ..... 7

Figure 1b. Detailing Considerations for Masonry (Sample Wall Section Details at Floor) ..... 7

Figure 1c. Detailing Considerations for Masonry (Sample Wall Section Details at Roof) ..... 8

Figure 2a. Detailing Considerations for Precast Concrete Panels  
(Sample Wall Section Detail at Vertical Span Precast Panels) ..... 10

Figure 2b. Detailing Considerations for Precast Concrete Panels  
(Sample Wall Section Detail at Horizontal Span Precast Panels) ..... 11

Figure 2c. Detailing Considerations for Precast Concrete Panels  
(Sample Plan Detail for Horizontal Span Precast Panels) ..... 12

Figure 2d. Detailing Considerations for Precast Concrete Panels  
(Sample Plan Detail for Vertical Span Precast Panels) ..... 12

Figure 2e. Detailing Considerations for Precast Concrete Panels  
(Sample Plan Detail for Horizontal Span Precast Panels at Inside Corner) ..... 13

Figure 2f. Detailing Considerations for Precast Concrete Panels  
(Sample Wall Section Details for Horizontal Span Precast Panels at Inside Corner) ..... 13

Figure 3. Detailing Considerations for Limestone Panels (Wall Section Detail) ..... 14

Figure 4. Detailing Considerations for Thin Stone Veneer Panels (Wall Section Detail) ..... 15

Figure 5. Detailing Considerations for Window Wall Enclosure Systems (Wall Section Detail) ..... 16

Figure 6. Detailing Considerations for Floor/Ceiling Sandwich ..... 17

Figure 7. Detailing Considerations for Diagonal Bracing ..... 18





## INTRODUCTION

This section has been developed to provide conceptual detailing considerations for various building enclosure systems (building skins) and their connections to different types of steel framing systems. The details are intended to identify issues that should be addressed in early phases of the project, as wall sections and interfaces with the structure are developed. Each type of enclosure system includes a commentary that elaborates on detailing considerations. Several references are given at the end of this section.

This section is not intended to be a comprehensive detailing guide. It is intended to identify issues that should be addressed in early phases of a project—when wall sections and enclosure systems are interfaced with the structure. The details are not intended to identify all necessary components of a weather tight enclosure system. Various regions of the country will have other details that are equally appropriate and cost effective.

## GENERAL CONSIDERATIONS

**Lateral System.** The type of lateral system used in a building will have a large impact on where the interior face of the enclosure system is located relative to the column centerlines. If diagonal bracing is used, the enclosure system and the interior wall finish, along with its supports, must clear the bracing members. Usually the bracing members are rods, angles, or structural tubes that are located on the column centerlines. If single angles are used, the vertical leg of the angle is attached to a gusset plate that is located on the column centerline and the horizontal leg is oriented either toward the interior or exterior face of the building. The horizontal leg should be oriented so as to avoid interference with the CMU back up and the interior wall finish supports. It should be noted that if a diagonally braced system is used, bracing is not required in every bay. Depending on the building size and configuration, bracing may only be required in one or two bays in each direction. Diagonally braced bays can sometimes accommodate doors and windows within the bay—provided the opening's frames and supports clear the bracing members.

If rigid moment frames or shear walls are used as the building's lateral system, the lateral system will not dictate the location of the enclosure system or interior wall finish surfaces. There are, however, cost implications and detail considerations that must be addressed if unbraced lateral systems are used. Additional information on lateral systems is given in the Systems Section of this Guide.

**Floor System.** The floor system shown is a steel floor deck with a concrete topping system. Typical floor system thicknesses range from 4 in. to 7.5 in. The thickness of the floor system is dependent on the floor loads, the distance that the system must span between beams, and the required fire rating. The metal deck can be either a composite steel floor deck, or a non-composite steel floor deck. A composite steel floor deck is a cold-formed steel deck that acts as a permanent form and as the positive bending reinforcement for the structural concrete topping. In other words, it is a steel deck which has dimples pressed in the deck which interlock with the cured cast-in-place concrete to form the tension reinforcing in the bottom of the slab. Non-composite steel floor deck is cold-formed steel deck that acts as permanent formwork for reinforced concrete slabs. It is only a form—the deck does not have dimples, and it does not act compositely with the concrete.

The floor system can be supported on either non-composite beams, or composite beams. Non-composite beams are standard steel beams that support the metal deck and concrete topping. Composite beams are steel beams that have headed studs welded to the top flanges of the beams after the metal deck has been installed. These studs interlock with the cured cast-in-place concrete and act together as a composite unit. The advantage of composite beams is that the steel depths and weights can usually decrease as a result of the composite action. It should be noted, however, that the resulting shallower floor system should be carefully checked for any floor vibration concerns.



Several other types of floor systems including cast-in-place concrete and precast concrete planks can be used with steel framing. Precast planks can economically span 10 to 40 ft between steel girders, depending on the floor load and plank thickness. Be careful, though, as long spans of planks may lead to deeper steel girders.

**Fireproofing.** Applicable building codes will determine the required fire ratings for various construction classifications. They also determine the required fire ratings for various components and systems within the building. All recognized fire rated systems are tested and passed by appropriate regulation standards agencies such as Underwriters Laboratories, or National Evaluation Service, Incorporated. Many types of fireproofing systems are available. Friable (soft) and cementitious fireproofing systems are generally the most cost effective types of spray-on systems. Intumescent paints may be a desirable solution as a fire-resistant coating for steel that is exposed to view.

Primed or painted surfaces can present potential adhesion problems for spray-on fireproof coatings. If paint is specified for structural steel that will subsequently be protected with spray-on fireproofing, e.g., metal deck, the architect should contact both the paint and fire protection suppliers, in advance, to ensure compatibility of the two products. Otherwise, bonding agents or costly field modifications may be necessary. Generally, as long as the steel surface is free of dirt and oil, the presence of light rust will not adversely affect the adhesion of spray-on fire protection.



## DETAILING CONSIDERATIONS FOR MASONRY

Sample plan and section details for masonry are given in Figures 1a, 1b, and 1c. These figures illustrate many of the concepts discussed in the GENERAL CONSIDERATIONS Section, as well as those discussed in this section.

**Enclosure System.** For the purpose of this Guide, the enclosure system is defined as the weather tight wall system that encloses the building. It is essential that the location of the enclosure system be determined relative to the column centerlines at an early stage of the project. Proper position of the enclosure system is critical because it can increase the chances for economical solutions to bracing systems, foundations, and perimeter framing member sizes in the building.

Concrete masonry units (CMU) have been selected as the back-up system for the masonry details. CMU was chosen because it has a long history of successful applications. Another viable back-up system that may be appropriate in various areas of the country is a metal stud back-up system. Consult a cost estimator for economic advantages of both systems in a particular area. A metal stud back-up system has been found to be economical for specific applications, however, it is generally a less forgiving system than CMU, and requires close attention to detailing and assembly of the system.

The following aspects of the enclosure system should be carefully considered:

- **Location of inside face of CMU relative to column centerline**

When considering the use of a brick and CMU enclosure system, the location of the entire enclosure system relative to the column centerline must be determined. The brick and block enclosure system should completely bypass the floor slab, perimeter beam flanges, as well as the column flanges, or the brick should bypass the slab while each floor slab supports the CMU.

There are advantages and disadvantages to both alternatives. If the masonry enclosure system bypasses the slab edge, the perimeter steel members do not support the load of the masonry at each floor, and therefore allow the perimeter steel members to be lighter and shallower.

The disadvantage of the masonry enclosure bypassing the slab edge is that the weight of the entire enclosure system would be supported directly on the perimeter footings or grade beams. This may require a larger and more expensive foundation. Furthermore, since no part of the exterior columns would be buried within the enclosure system, the columns would have a larger projection into the building's usable spaces. It should be noted that the location of the inside face of the masonry enclosure system would be dictated by clearances required for the largest column or widest beam flange at the perimeter of the building.

It should also be noted that when a building has a high overall ratio of openings to remaining walls, a system where the masonry bypasses the steel frame is a preferred solution.

- **Location of face brick relative to edge of slab**

There are basically two options for the location of the building's face brick relative to the floor slab edge. It can either bypass each floor, where the entire weight of the brick is supported on the perimeter foundation wall, or the brick can be supported on shelf angles at various floor levels.

If the vertical height of the building exceeds approximately 30 ft, it may be necessary to support the brick on shelf angles at periodic horizontal elevations. A structural engineer should be consulted to assist with this determination. However, if shelf angles are not required, it is generally more economical to support the entire weight of the face brick on the foundation wall. Note that some codes may require support at each floor.



- **Location of CMU and face brick for parapet detailing**

Depending on where the enclosure system is located relative to the column the CMU will either bypass the perimeter steel beam at the roof or it will not. If the CMU bypasses the perimeter centerline the CMU may extend above the roof as a cantilever and provide lateral support for the roof parapet. A structural engineer should be consulted to determine the maximum height where the CMU can support the parapet.

If the CMU does not bypass the steel framing, the continuity of the CMU will be lost and provisions will need to be made to prevent movement or rotation of the parapet above the roof.

**Masonry Anchors.** If the masonry walls span vertically between floors, adjustable anchors at a column would be a redundant form of reinforcement. Anchors at columns can also increase the cost of a masonry wall system, since a steel detailer would need to detail each anchor on each column (assuming that this is in the detailer's scope of work). If the anchors are field installed, anchor installation must be coordinated with the fireproofing contractor. It is expensive to remove fireproofing and install anchors to a column after the column has been fireproofed.

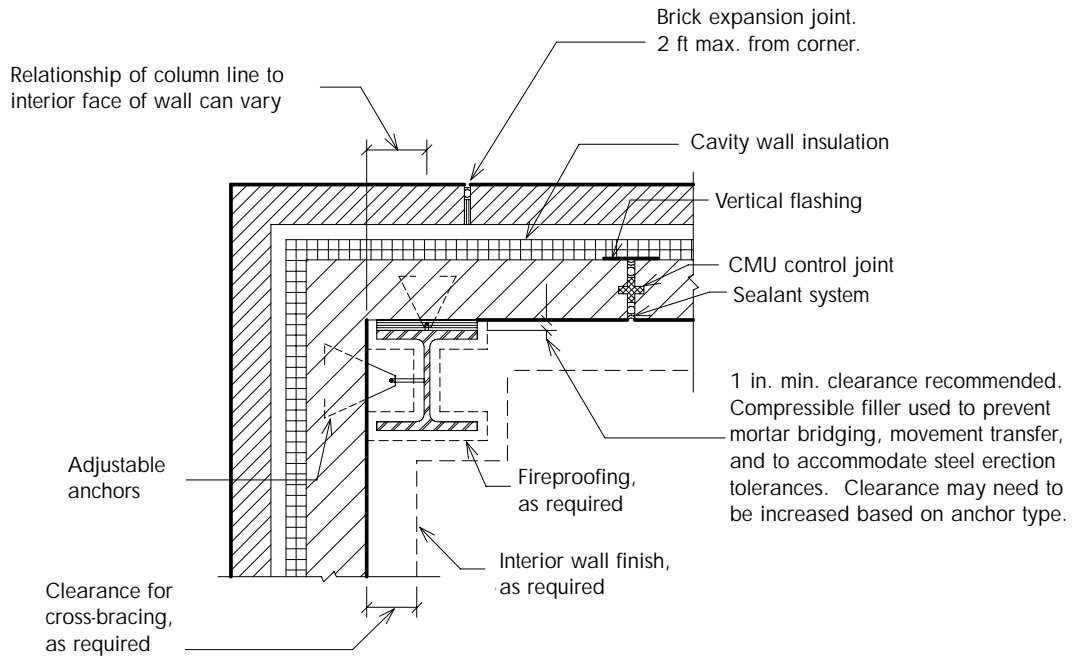


Figure 1a. Detailing Considerations for Masonry (Plan Detail at Masonry Corner)

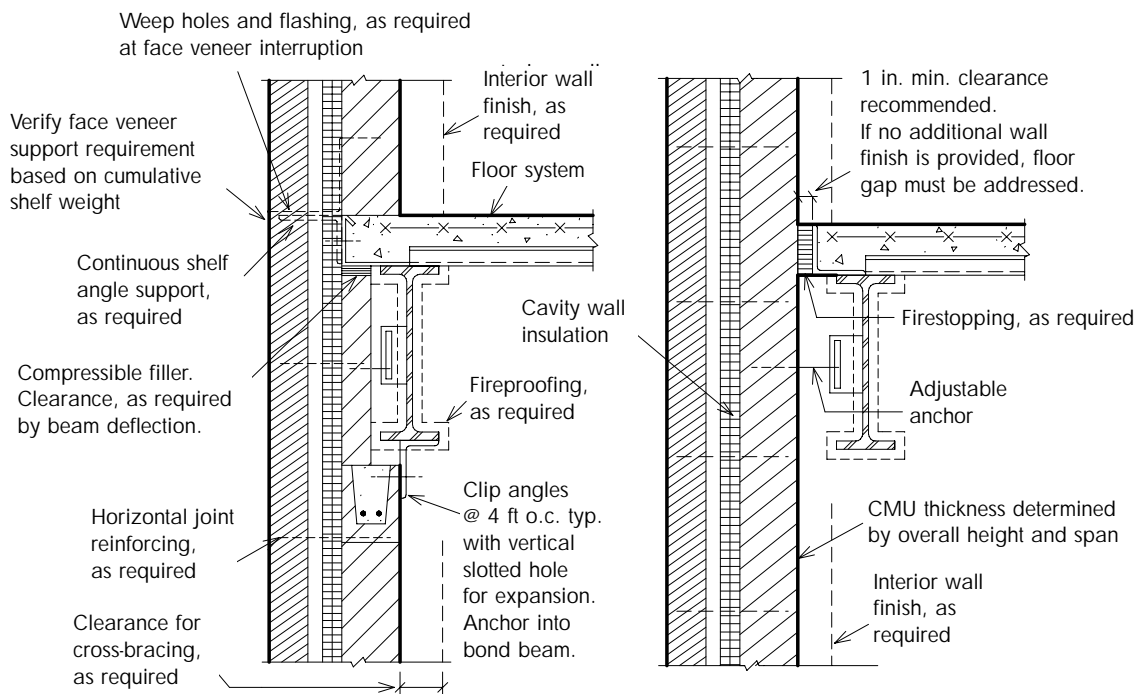
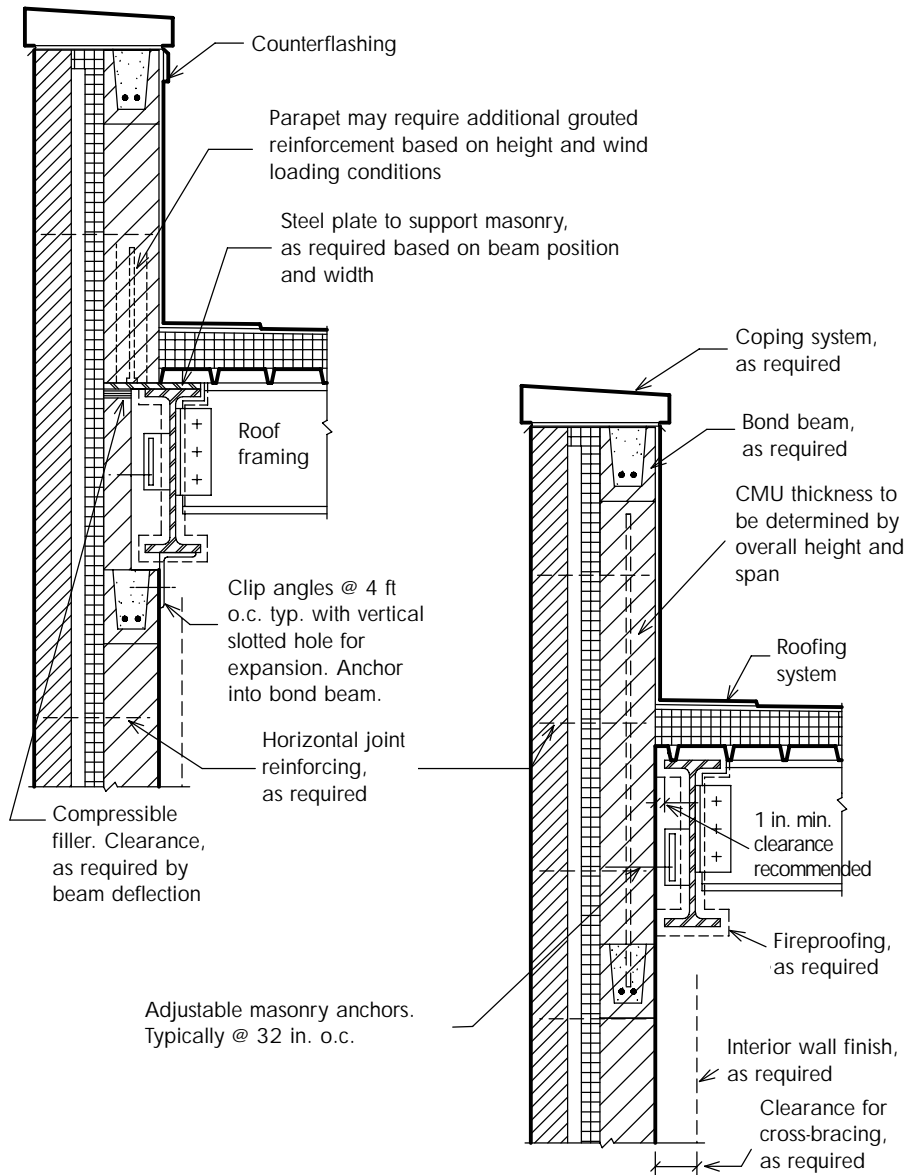


Figure 1b. Detailing Considerations for Masonry (Sample Wall Section Details at Floor)



**Figure 1c.** Detailing Considerations for Masonry (Sample Wall Section Details at Roof)



## DETAILING CONSIDERATIONS FOR PRECAST CONCRETE PANELS

Sample plan and section details for precast concrete panels are given in Figures 2a-2f. These figures illustrate many of the concepts discussed in the GENERAL CONSIDERATIONS Section, as well as those discussed in this section.

**General Considerations.** Precast concrete panels can be an attractive and economical enclosure system for appropriate applications. Precast panel systems are most economical when the panel sizes are 20 ft to 30 ft in length, and the panel width/height is limited to approximately 14 ft.

**Gravity Load.** Precast concrete panels are generally supported one of three ways. One way to support the panels is to span the panels horizontally between columns. The panels may also be supported at each floor level by the perimeter beams. Otherwise the panels may be stacked on each other and supported by the building's foundation. Obviously, a large building height may limit the feasibility of stacking the precast panels. The panel profile and structural bay size will determine the most economical panel support system.

**Wind Load.** Precast concrete panels can be designed to span either vertically or horizontally for the applied wind load. If the panels are designed to span vertically, they are generally laterally supported at each floor level or by a secondary lateral support system that transfers the lateral load to the primary structure. If the panels are designed to span horizontally, they are laterally supported at the columns as well as intermittent lateral supports at the floor levels. Precast concrete panels are usually designed as part of the enclosure system only, and not designed to be incorporated as part of the building's lateral system.

**Construction Tolerances.** All enclosure systems must have tolerances for deviations in materials and the construction process. Connections of precast panels to a steel frame must provide flexibility in all directions for field installation of the connection. Generally, it is not the architect's responsibility to design the connection, but the architect should recognize flexibility for field tolerances.

**Connections.** There are numerous ways to connect precast concrete exterior wall panels to the supporting steel frame. The precast panel manufacturer will generally determine the final details of the connection. It is, however, the architect's responsibility to make adequate provisions for proper support and construction tolerance of the panels. Some precast manufacturers prefer to bear the panels on recessed pockets within the panels that are supported directly on seated connections or haunches from beams or columns. The seated connections or haunches minimize the eccentricity of the panel self-weight on the support connection. Other support options include such assemblies as structural angles or channels attached to the columns or beams which would support embedded angles located on the back of the precast panels.

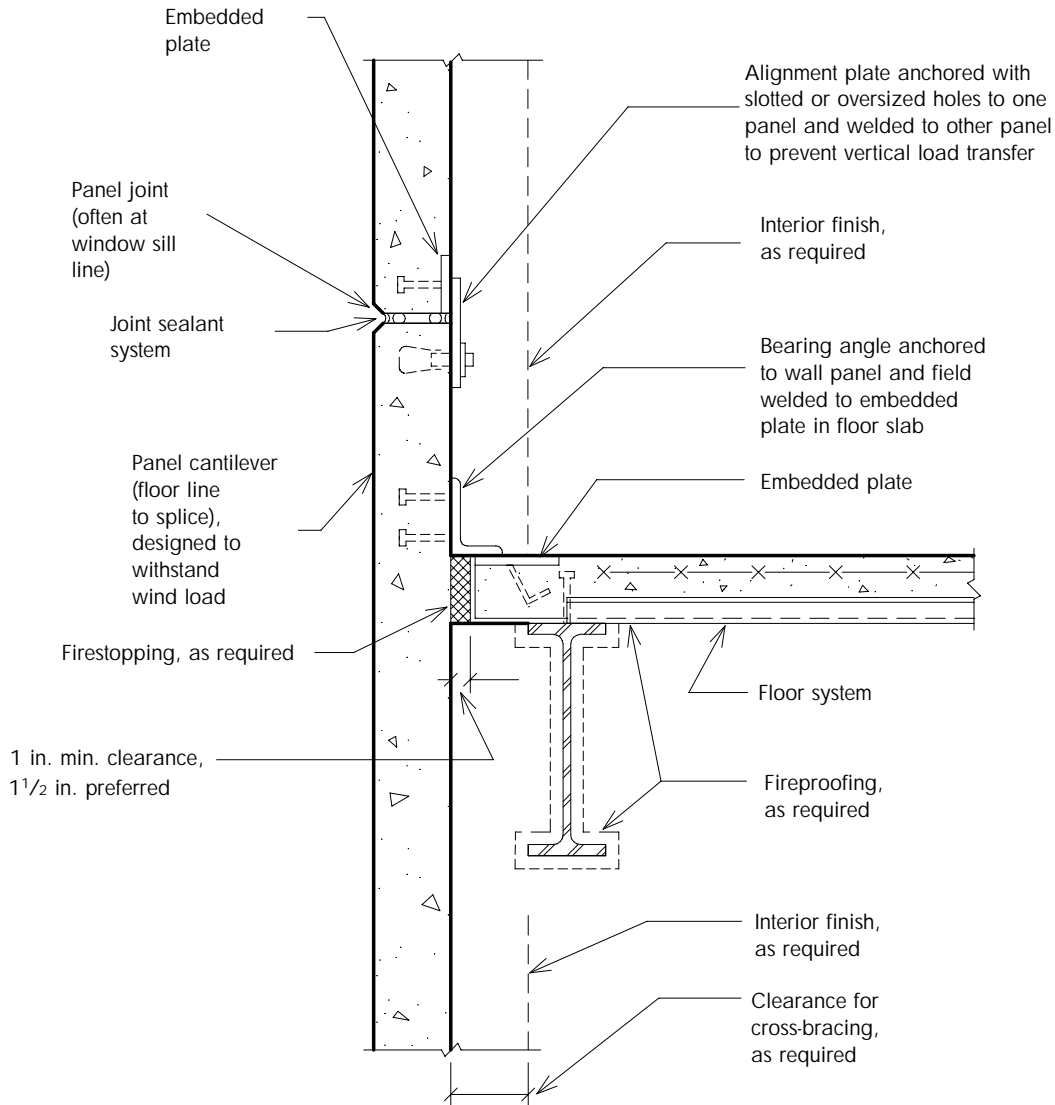
**Inside Corners.** One of the most overlooked conditions when detailing precast panel systems is the inside corner condition. This is a particularly important condition when using panels that span horizontally. The reason that inside corners must be carefully considered is because, unless carefully detailed, the panel may not have adequate support. Due to the column location at the corner configuration, the panels cannot be supported directly from the column. Instead, the panels are supported directly on the spandrel members or on the concrete slab above the spandrel members.

There are typically three methods to support precast panel ends at inside corners. The first method is to have each spandrel member act as the sole support for the panels near the column. This method can be successful if the spandrel is properly designed. Since the panels will have a tendency to roll or rotate, the spandrels must be designed for the torsional forces induced by the eccentricity of the precast panel. This method usually results in heavier spandrel members, but it does eliminate the need for stiffeners and braces. The second method is simi-



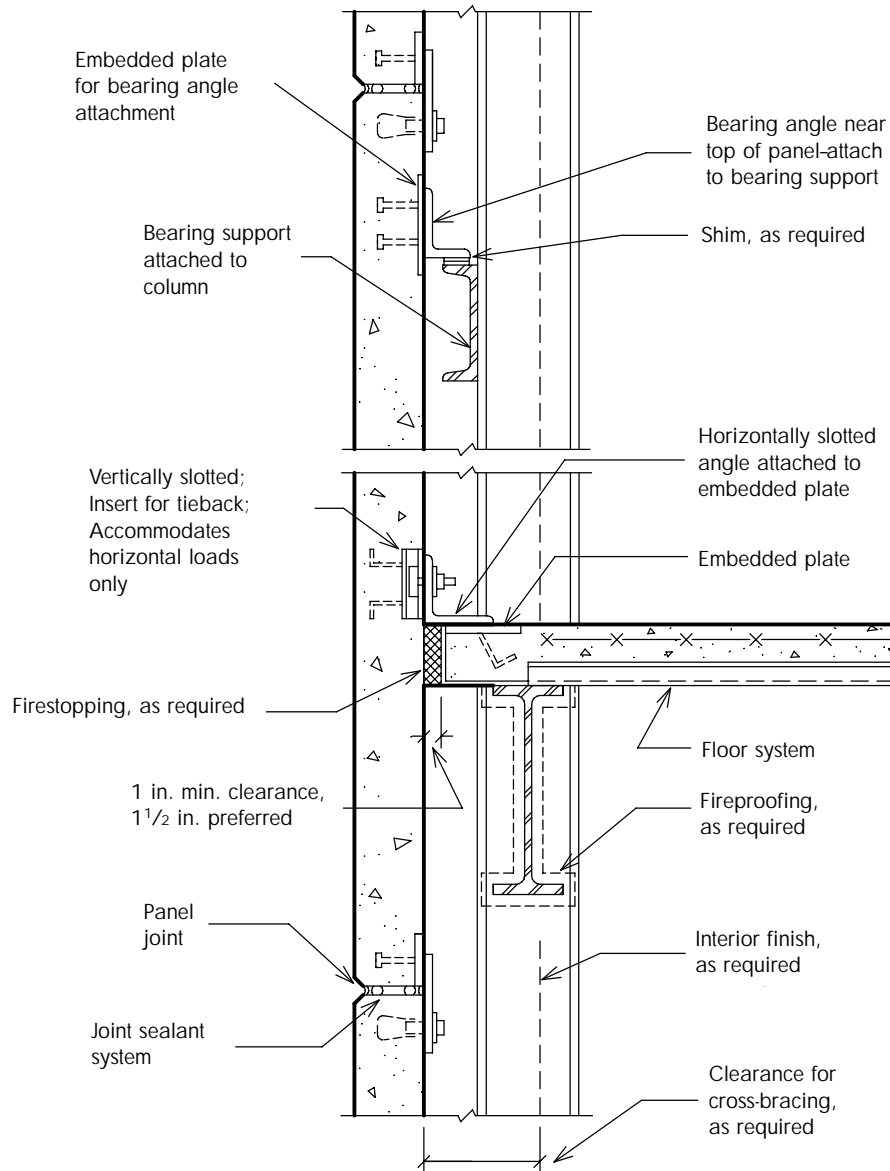
lar to the first method except that the spandrel members alone do not resist the torsional forces in the spandrel. A steel member is placed perpendicular to the spandrel at the point where the panel is supported. This solution will decrease the size of the spandrel members, but the additional perpendicular steel may be undesirable, or conflict with other building systems. The third method is to provide stiffener plates and kickers to resist the torsional effects on the spandrel beams. This has been a successful solution, but the stiffeners will increase the steel fabrication costs.

Supporting the horizontal spanning panels directly from the columns at an inside corner is not a suggested detail. To support directly from the column, the panels would have to be supported on steel members that cantilever horizontally from the column to the panel. The panel loads would be eccentric to the column, and would increase the bending and torsional stresses on the column. Furthermore, since both of the panels need to be supported from the same column, the cantilevered members would be at different elevations—creating a non-typical bearing support condition of the corner panels.

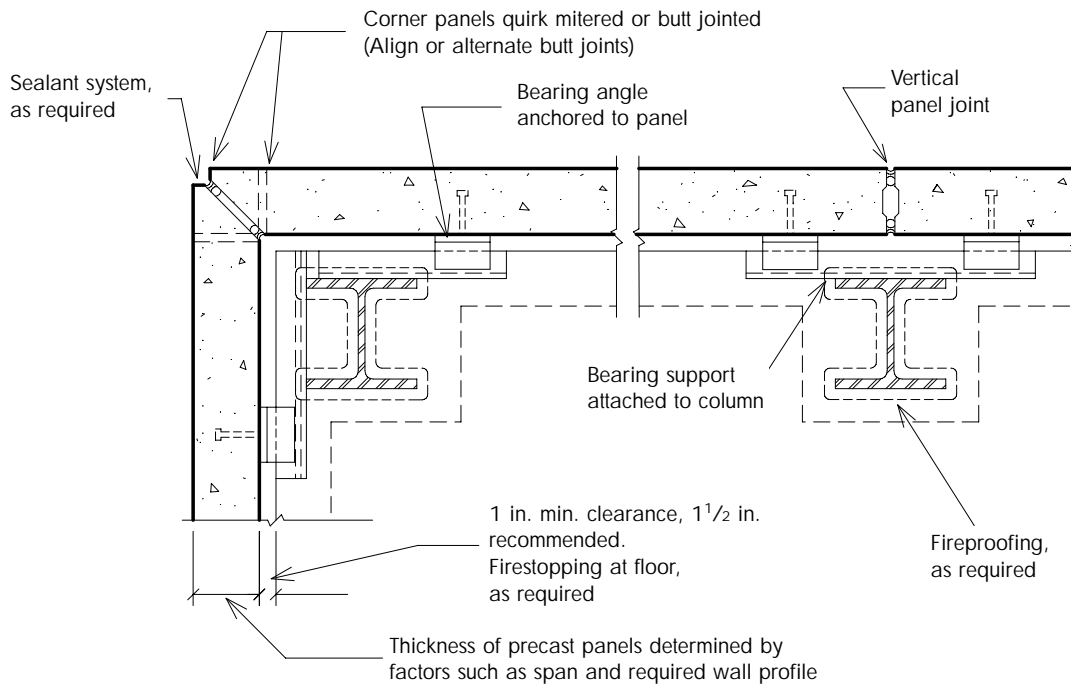


**Figure 2a.** Detailing Considerations for Precast Concrete Panels (Sample Wall Section Detail at Vertical Span Precast Panels)

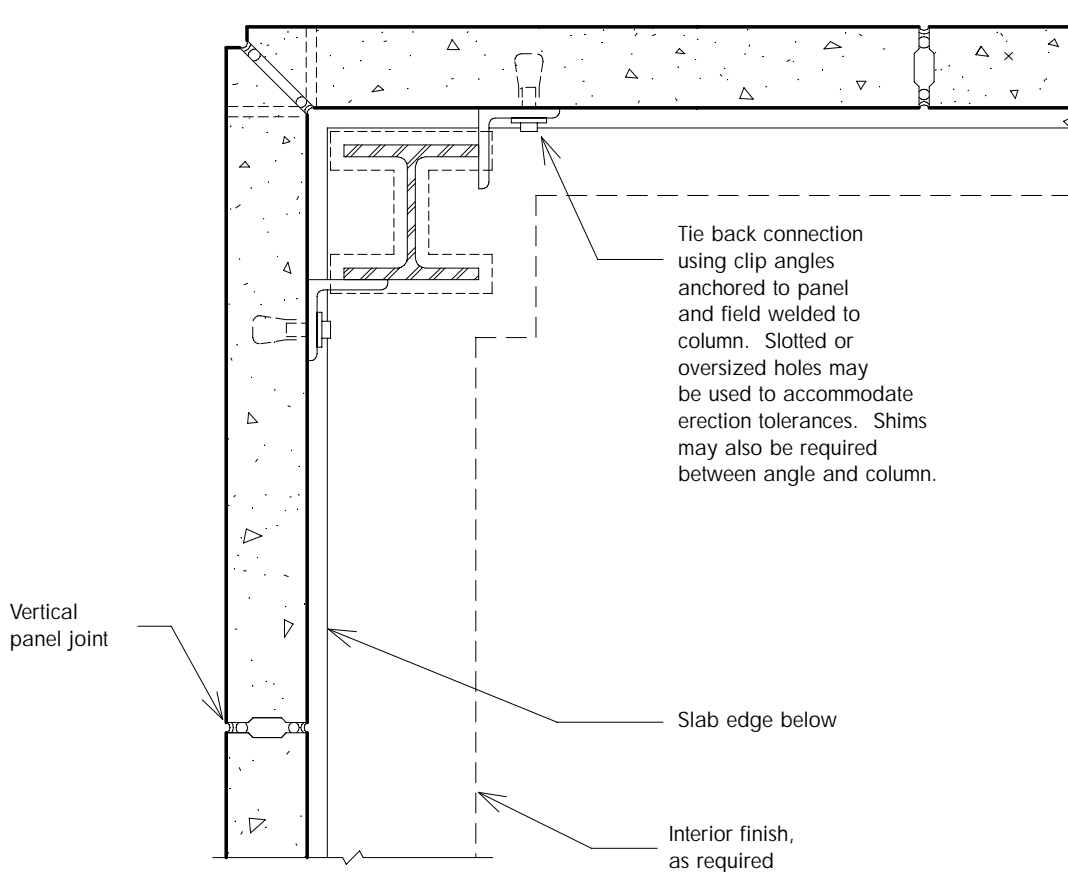




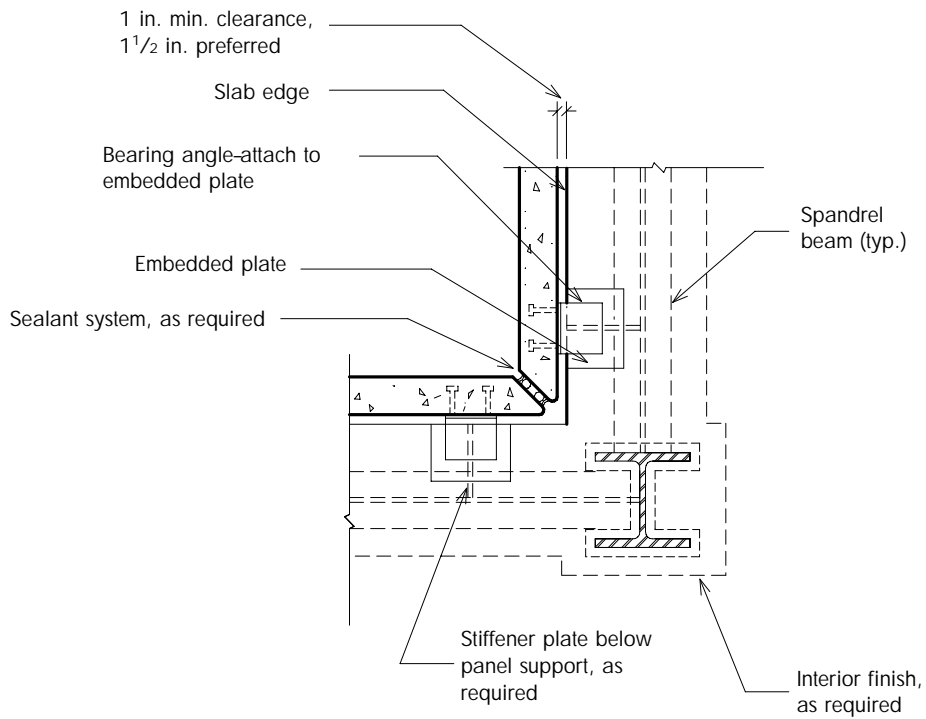
**Figure 2b.** Detailing Considerations for Precast Concrete Panels (Sample Wall Section Detail at Horizontal Span Precast Panels)



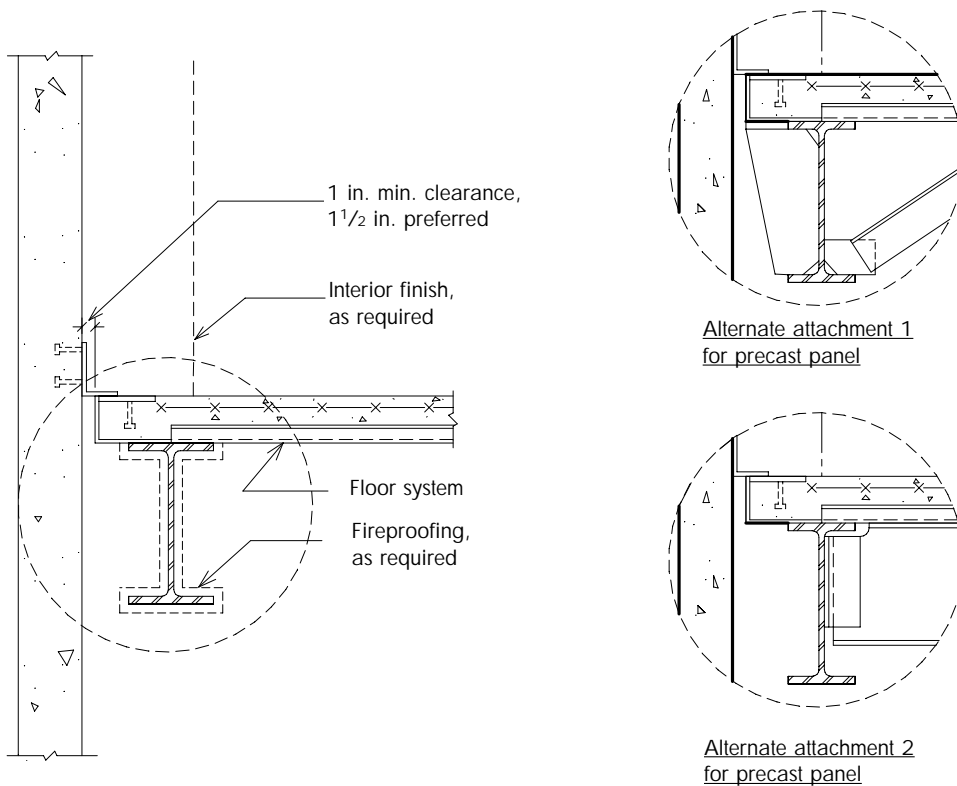
**Figure 2c.** Detailing Considerations for Precast Concrete Panels (Sample Plan Detail for Horizontal Span Precast Panels)



**Figure 2d.** Detailing Considerations for Precast Concrete Panels (Sample Plan Detail for Vertical Span Precast Panels)



**Figure 2e.** Detailing Considerations for Precast Concrete Panels  
(Sample Plan Detail for Horizontal Span Precast Panels at Inside Corner)



**Figure 2f.** Detailing Considerations for Precast Concrete Panels  
(Sample Wall Section Details for Horizontal Span Precast Panels at Inside Corner)



## DETAILING CONSIDERATIONS FOR LIMESTONE PANELS

A sample wall section detail for limestone panels is given in Figure 3. The figure illustrates many of the concepts discussed in the GENERAL CONSIDERATIONS Section, as well as those discussed in this section.

**Anchors.** The term "anchor" generally refers to straps, rods, or other connections between limestone and the structure. Most anchors are intended to hold limestone panels in their vertical position, as opposed to supporting the weight of the limestone. All anchors embedded in limestone should be a non-corrosive material (stainless steel, brass, bronze). Limestone anchors are typically embedded in the stone with mortar. Therefore, stainless steel or other non-corrosive materials will reduce the chance of staining and spalling problems resulting from corrosion of the anchor steel. Carbon steel of adequate strength may be used for supports that are not embedded in stone. It is recommended that a limestone fabricator be consulted for further detailing information.

**Back-up Systems.** Panel thickness, panel span, and wind load requirements, will all be variables in determining the proper back-up system for the limestone panels. The back-up system could be any material that is compatible with limestone and is stiff enough to limit the horizontal deflection and maintain the integrity of the panels. Typically, a steel sub-frame system is used as a back-up system, as illustrated in Figure 3. CMU may be considered as a back-up system, but it is usually most appropriate for smaller panel sizes and lighter overall loading conditions.

**Supports.** Unlike precast concrete panels, limestone panels should always be vertically supported at the bottom of the panel. If the panel bears on the panel directly below it (see Figure 3), non-corrosive anchors should be used to connect the two panels. If the panels are supported on steel angles with "grab rods," the angles may be carbon steel that is galvanized or painted, but the steel rods should be a non-corrosive material.

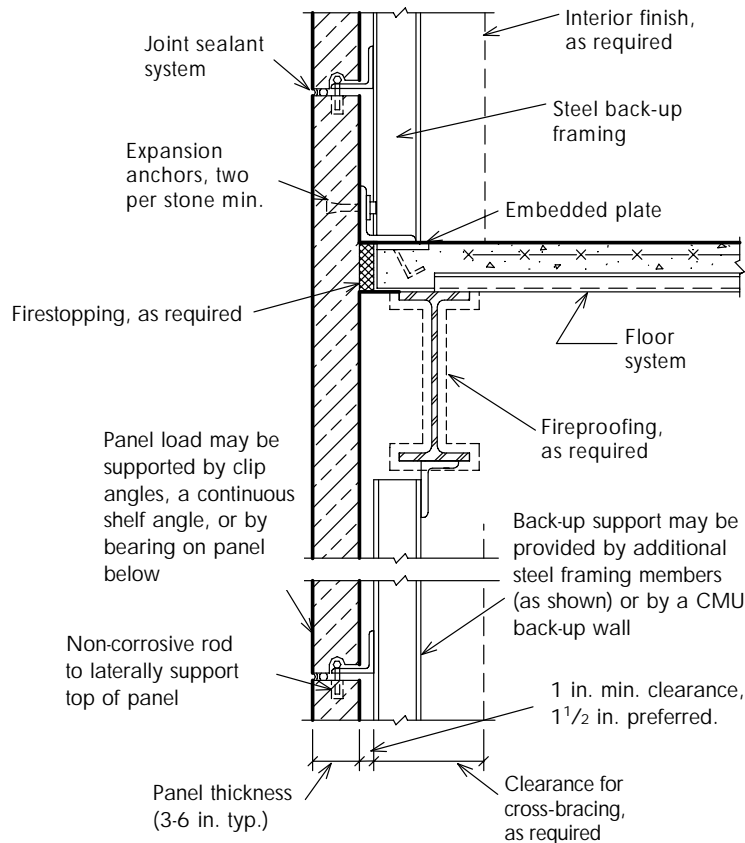


Figure 3. Detailing Considerations for Limestone Panels (Wall Section Detail)



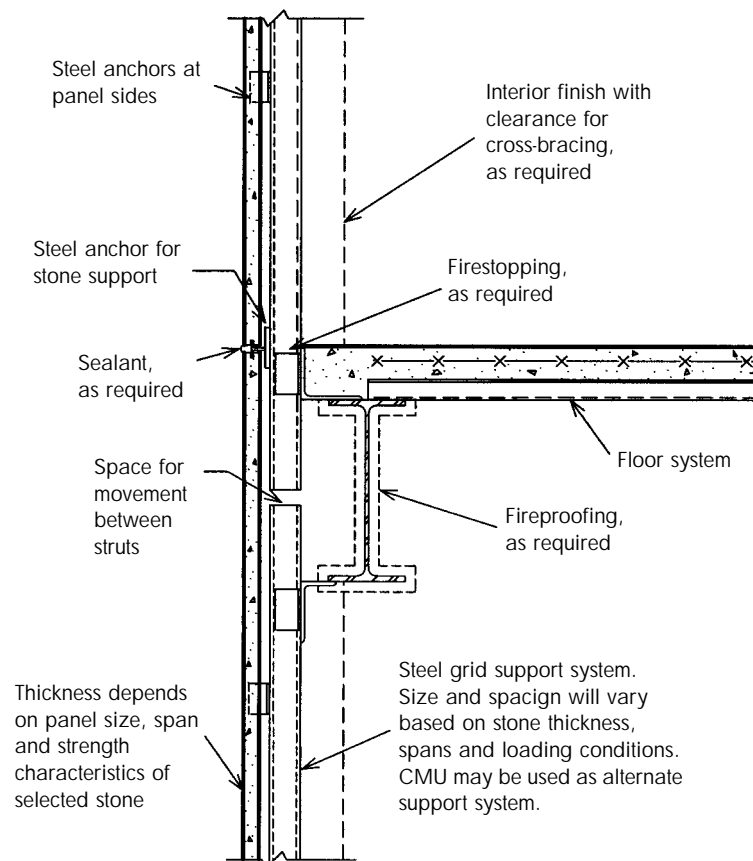
## DETAILING CONSIDERATIONS FOR THIN STONE VENEER PANELS

A sample wall section detail for thin stone veneer panels is given in Figure 4. The figure illustrates many of the concepts discussed in the GENERAL CONSIDERATIONS Section, as well as those discussed in this section.

**General Design Considerations.** Thin stone panels are products of nature. As a result, they have different physical properties—even stones from within the same quarry. For example, the strength characteristics of a granite panel may be as much as 150 percent of another granite panel. When selecting a thin stone veneer system, architects should carefully consider: the physical properties of the stone to be selected, design criteria for the veneer, evaluate the interrelationship of the exterior wall assembly, and determine/clarify the structural engineering responsibilities of the stone veneer and the anchoring system. See Figure 4 for a sample wall section detail.

**Back-up System.** A grid strut back-up system will be required to laterally and vertically support the thin stone. The back-up system is generally a steel sub-frame system, or a CMU wall. Consult a stone fabricator for detailing information and deflection limitation criteria.

**Anchors.** Because of the variety of strengths between stones, even between stones from the same quarry, stone panel anchors need to be chosen very carefully. There are hundreds of different anchors that are inserted into a kerf or slot cut into a hole drilled into the sides or rear of the stone panels. Choosing the appropriate anchor, based on the panel size, thickness and back-up system is critical to the success of thin stone veneer panel systems.

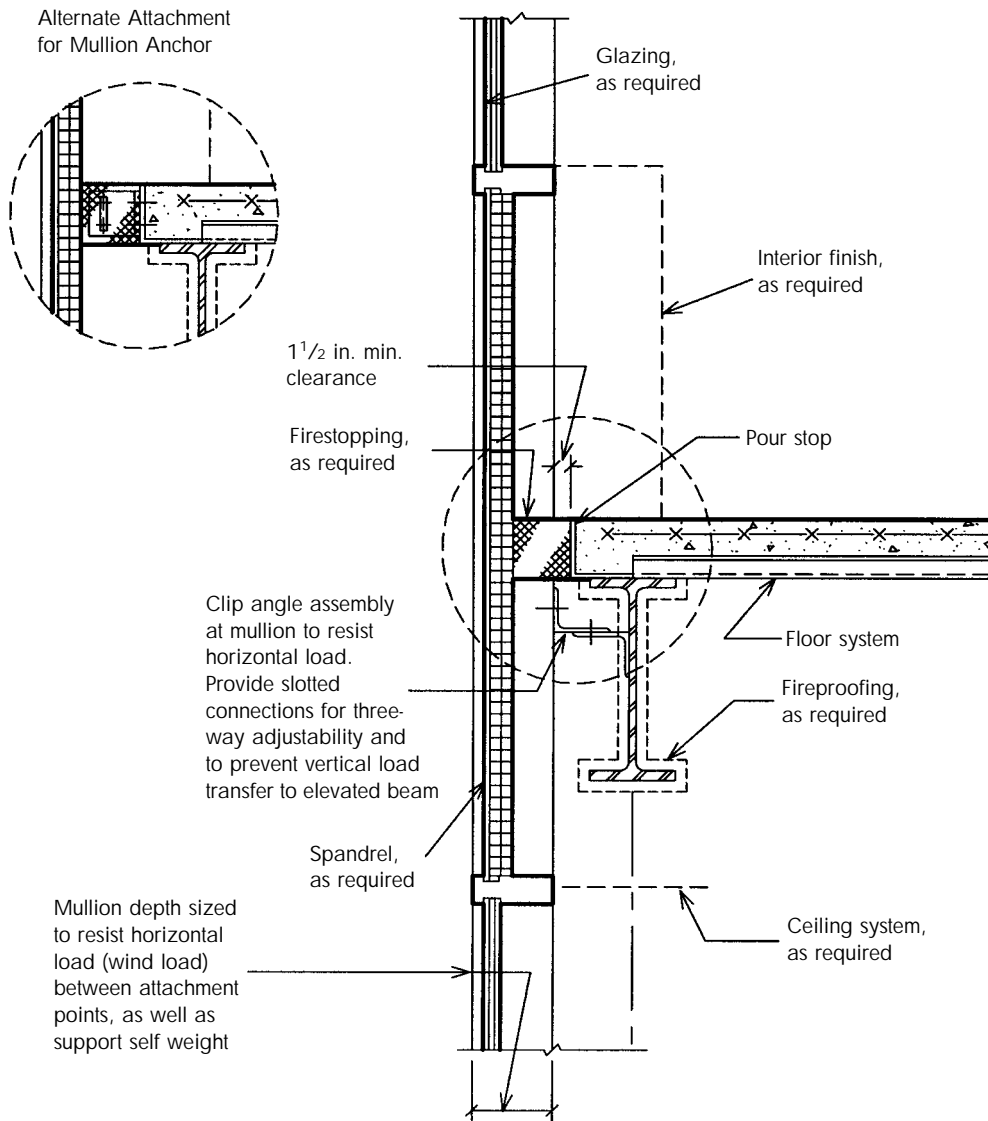


**Figure 4.** Detailing Considerations for Thin Stone Veneer Panels (Wall Section Detail)



## DETAILING CONSIDERATIONS FOR WINDOW WALL ENCLOSURE SYSTEMS

**General Considerations.** Window wall systems have a lateral load resisting structural system within themselves. The mullions of the window wall system provide support to transfer the exterior wind loads on the glazing to the primary building structure. Generally speaking, the glazing will span in the short direction between mullions. Therefore, depending on the proportions and orientation of the glazing, the structural mullions will span either horizontally or vertically. Consult a window wall manufacturer to determine practical mullion locations and depths. It should be noted that mullions could be reinforced with steel to increase their strength without increasing their depth. See Figure 5 for a sample wall section detail.



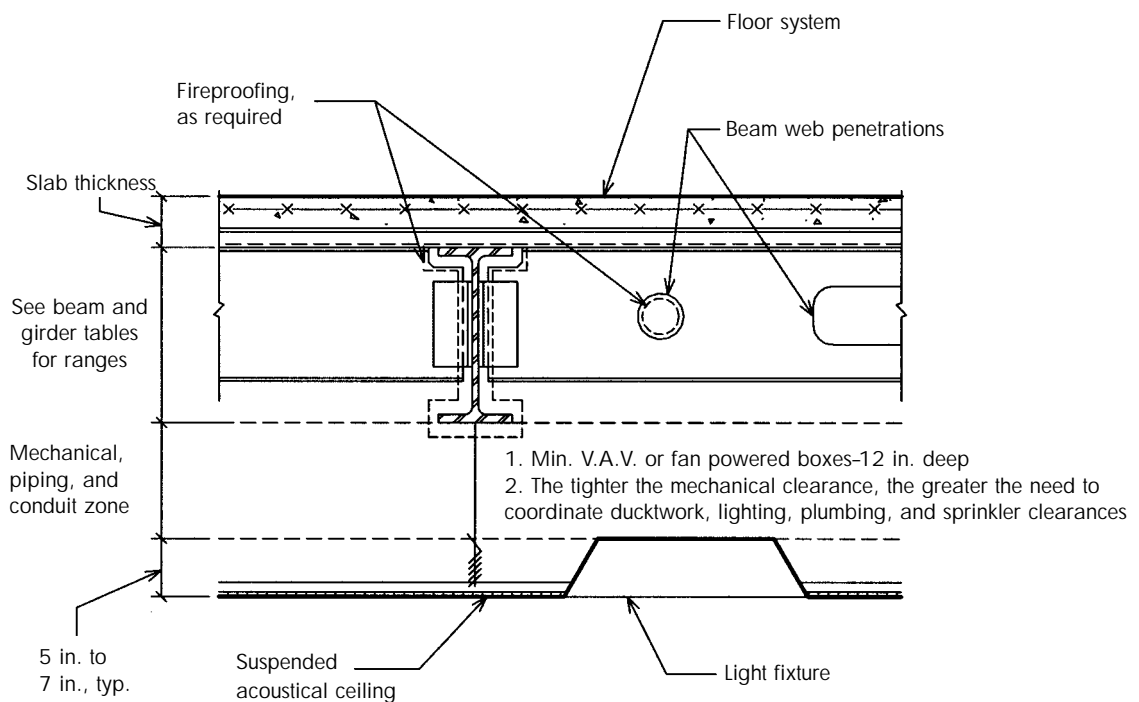
**Figure 5.** Detailing Considerations for Window Wall Enclosure Systems (Wall Section Detail)



## DETAILING CONSIDERATIONS FOR FLOOR/CEILING SANDWICH

A typical floor/ceiling sandwich detail is given in Figure 6.

**M.E.P. Space.** Evaluating space requirements for mechanical, electrical, and plumbing systems can be difficult to do at an early phase of a project. Unfortunately, that is when types of system decisions need to be made. Probably the most important system decision to be made is to determine the approximate sizes of the mechanical ductwork. Consult a mechanical engineer for this information. Also, general locations of major ductwork or piping crossovers should be identified. Crossovers can be the type of problem area that require lowered ceilings and expensive beam web penetrations if sufficient space is not provided when the ceiling sandwich depth is determined.



Note: Due to the extent, complexity, and frequency of revisions, hospitals require the largest mechanical zones

**Figure 6.** Detailing Considerations for Floor/Ceiling Sandwich



## DESIGN CONSIDERATIONS FOR DIAGONAL BRACING DETAILS

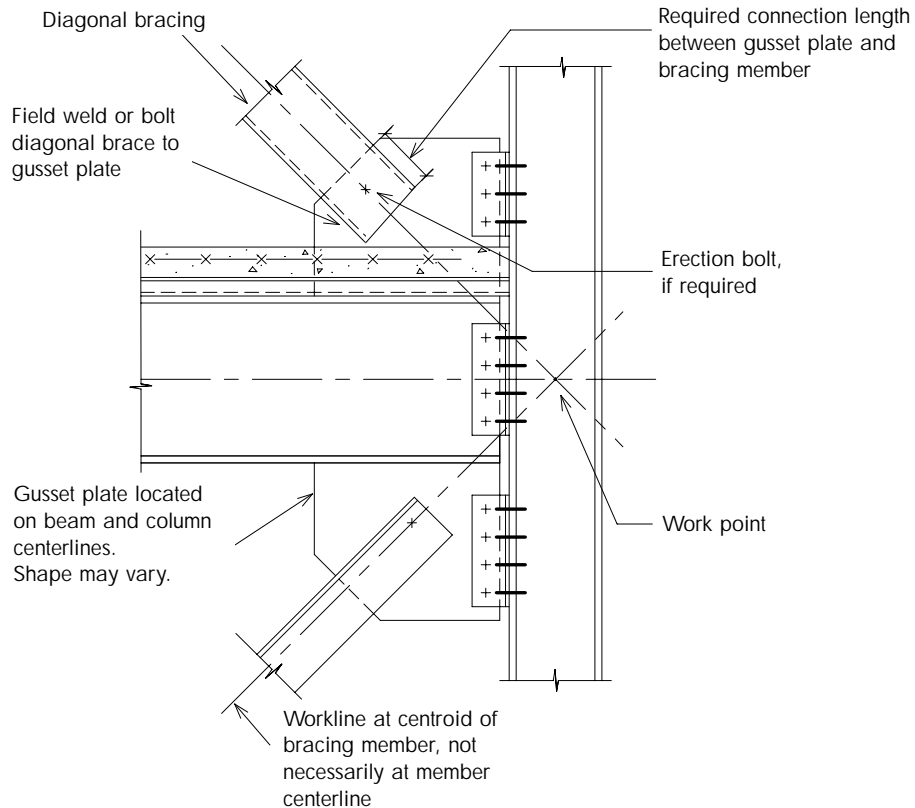
A sample diagonal bracing detail is given in Figure 7.

**General.** Buildings that use diagonal braces for the lateral system can be extremely economical (see the Systems section of this manual). However, the disadvantage of diagonal braces is that the braces may conflict with ideal locations for doors or windows. In order to minimize any sort of conflict between the bracing and the doors/windows, it is important to understand exactly what shape the brace member is, and where it is located.

It is desirable to have the work lines of all of the connecting members intersect at one work point (see Bracing Detail). The work lines run through the centroids of the members. If the member is not symmetrical, the work line is not at the mid-depths of the member, i.e., the centroid of an angle is not at the mid-depths of the angle. This is essential to understand when determining whether or not a window or doorframe will bypass the brace.

**Gusset Plates.** Gusset plates may be a variety of sizes and shapes. It will be dictated by the force in the diagonal brace and the thickness of the gusset plate. If the gusset plate is hidden within a wall, the size and shape of the gusset plate generally is not an issue. However, if the gusset plate is exposed, there are virtually endless possibilities for its shape. However, the size of the gusset plate may be governed by the amount of area that the diagonal brace must overlap the gusset plate in order to achieve an adequate connection. To minimize the gusset plate sizes, the diagonal brace may actually start below the finished floor surface, as shown in the detail.

**Work Lines.** The "work line" for the bracing member, located at the centroid of the bracing member, may not necessarily be at the mid-depths of the member. This would be the case for non-symmetrical members such as WT-shapes and angles. Also, the angle of the bracing member at a floor may be at a different angle from a floor above or below it. This would occur if the floors had different floor-to-floor heights.



**Figure 7.** Detailing Considerations for Diagonal Bracing





**Bracing Members.** Bracing members can consist of virtually any structural shape. Typically, rods, single angles, double angles, WT-shapes, and hollow structural sections are used for diagonal members in tension. Sometimes, wide flange shapes are used if the bracing forces are extremely large.

**Work Point.** The work point is the intersection point of all of the work lines. It should be noted that it is desirable, but not always necessary, for the work lines to intersect at a work point. If the work lines do not intersect at a work point, the connections must be designed for these eccentricities. As a result, the members may increase in size. Consult a structural engineer if this situation must be investigated.

## ADDITIONAL REFERENCES

*Masonry and Steel Detailing Handbook*, Walter Laska, The Aberdeen Group, 1993.

Coatings for Fire Protection in Utility Plants, E. Bud Senkowski, *Journal of Protective Coatings and Linings*, 1995.

*Indiana Limestone Handbook*, Indiana Limestone Institute of America, Inc., Stone City Bank Building, Suite 400, Bedford, Indiana 47421, (812) 275-4426, [www.iliai.com](http://www.iliai.com).

Testing Thin Stone Veneers, John P. Stecich, Ian R. Chin, and F. Dirk Heidbrink, *Masonry Construction*, March 1991.

Anchoring Thin-Stone Veneers, *Architecture*, December 1993.





# CONTENTS OF APPENDIX

## COMMON QUESTIONS ANSWERED

DEFINITIONS .....	3
MILL PRODUCTION AND TOLERANCES .....	3
Cross-sectional and Straightness Tolerances .....	3
Surface Condition .....	4
Ordering Steel .....	5
Other General Information .....	5
GENERAL FABRICATION .....	6
Material Identification and Traceability .....	6
Cutting and Finishing Steel .....	7
Use of Heat in Fabrication .....	10
Bolt Holes .....	10
Correction of Fabrication Errors .....	11
Other General Information .....	12
FABRICATION AND ERECTION TOLERANCES .....	13
Member Cross-sectional Tolerances .....	13
Member Straightness Tolerances .....	13
Element Location Tolerances .....	14
Erection Tolerances .....	15
Other General Information .....	15
PAINTING AND SURFACE PREPARATION .....	17
Painting Requirements .....	17
Paint Film Thickness .....	18
Surface Preparation Requirements .....	19
SSPC Surface Preparation Levels .....	20
Field Touch-up and Repair .....	21
Other General Information .....	21
FIRE PROTECTION .....	22
Fire Protection Systems .....	22
Fire Exposure .....	22
REFERENCES .....	23
CODE OF STANDARD PRACTICE FOR STEEL BUILDINGS AND BRIDGES, MARCH 7, 2000 .....	25
CONSTRUCTION INDUSTRY ORGANIZATIONS .....	117





## COMMON QUESTIONS ANSWERED

This section of the Appendix contains a listing of frequently asked questions (FAQs), along with answers. The reader is encouraged to visit [www.aisc.org/faq.html](http://www.aisc.org/faq.html) for a more comprehensive and regularly updated listing of FAQs. Additionally, the reader is encouraged to visit the quality certification portion of [www.aisc.org](http://www.aisc.org) for questions on quality certification.

### DEFINITIONS

The following terms and abbreviations appear throughout the text of this section. In general, defined terms are capitalized in the text.

AESS	Architecturally exposed structural steel, as defined in the <i>AISC Code of Standard Practice</i> Section 10
AISC	American Institute of Steel Construction
ANSI	American National Standards Institute
ASCE	American Society of Civil Engineers
ASME	American Society of Mechanical Engineers
ASTM	American Society of Testing and Materials
AWS	American Welding Society
CMTR	Certified mill test report
HSS	Hollow structural section
Mill	The steel material manufacturer
RCSC	Research Council on Structural Connections
SER	Structural Engineer of Record
SSPC	Steel Structures Painting Council

**Statically Loaded Structures.** Structures subject to loading that characteristically is slowly applied and removed, as would be typical in building, sign, and tower structures; dead, live, wind and similar loads are generally considered to be static

**Cyclically Loaded Structures.** Structures subject to loading that is applied and/or removed at a rate that cannot be considered to be static and requires consideration of fatigue, as would be typical in bridge structures and crane runways

### MILL PRODUCTION AND TOLERANCES

#### Cross-sectional and Straightness Tolerances

*Where are the (mill) dimensional tolerances for structural shapes and plates given?*

Permissible variations for structural shapes and plates as received from the mill are established in ASTM A6/A6M-01 Section 12. These historically developed standard tolerances define the acceptable limits of variation from theoretical dimension for the cross-sectional area, flatness, straightness, camber, and sweep for rolled sections.



It should be noted that cross-sectional tolerances are expressed as a percentage of weight or area, not as tolerances on dimensions such as the flange and web thicknesses.

Generally, standard fabrication practice accommodates these structurally acceptable variations. In special cases such as high-rise construction, the accumulation of mill tolerances may require consideration in design by the SER. If more restrictive tolerances are required, they must be specified in the contract documents.

## Surface Condition

*Where are the permissible variations in surface condition for structural shapes defined?*

ASTM A6/A6M-01 Section 9 defines the permissible variations in the surface condition for structural shapes and plates in the as-rolled condition. It should be recognized that surface imperfections, such as seams and scabs, within these specified limits may be present on material received at the fabrication shop; particularly on heavy-weight cross-sections because of higher finishing temperatures and production difficulties. Certain steel chemistries, such as that for ASTM A588, will also exhibit a higher incidence of surface imperfections.

Special surface-condition requirements must be specified in the contract documents. Material purchased to meet the requirements of ASTM A6/A6M is usually subject to acceptance or rejection based upon visual inspection both at the rolling mill and at the time of receipt by the fabricator, although more extensive inspection methods may be used. This inspection is important because mills normally limit their contractual liability to replacement or credit. Because occasional surface imperfections may be discovered after the fabricator's acceptance of mill material, particularly after blast cleaning, any requirements for remedial work should also be specified in the contract documents.

*What corrective procedures are available to the mill when variations in surface condition do not meet specified tolerances?*

ASTM A6/A6M-01 Section 9 specifies limited conditioning that the mill may perform when as-rolled material does not meet specified tolerances. Note that it further states that "conditioning of imperfections beyond the [specified] limits ... may be performed by [the fabricator] at the discretion of [the fabricator]".

Unless required in the contract documents, code-compliant surface imperfections generally need not be repaired or removed if they are not detrimental to the strength of the member. When required, they may be repaired by grinding or welding. The responsibility for any required repairs should be assigned in the contract documents so that it is clearly understood by all parties involved, including the owner's representative (e.g., general contractor), fabricator, erector, and painter.

*How should edge discontinuities in mill material be treated?*

Non-injurious edge discontinuities in Statically Loaded Structures need not be removed or repaired, unless otherwise specified in the contract documents. Injurious defects, such as a longitudinal discontinuity that will be subjected to through-thickness loading, should be repaired by welding and/or grinding. The requirements for treatment of such edge discontinuities must be clearly specified in the contract documents and the repair procedure should be approved by the SER.

In Cyclically Loaded Structures, the provisions of AWS D1.1:2000 Section 5.15.1.2 for edges that are to be welded are appropriate for non-welded edges, except that:



1. With the approval of the purchaser, discontinuities need not be explored to a depth greater than 1 in. When the depth of a discontinuity exceeds 1 in., the discontinuity should be gouged out to a depth of 1 in. beyond its intersection with the surface and repaired by the deposition of weld metal as indicated in AWS D1.1:2000 Section 5.15.1.1.
2. For discontinuities over 1-in. long, with depth exceeding 1/8 in. but not greater than 1 in., the discontinuity must be removed and repaired, but no single repair should exceed 20 percent of the length of the edge repaired.

## Ordering Steel

*What information is required to be reported in a Certified Mill Test Report (CMTR)?*

The information required to be reported in a CMTR is as given in ASTM A6/A6M-01 Section 14. This includes but is not limited to the steel grade and nominal sizes supplied and tension test results. This document may be in written form or, per ASTM A6/A6M-01 Section 14.8, transmitted electronically.

*What must the specifier indicate when material is subject to a domestic purchasing requirement?*

When a domestic purchasing requirement is in effect for a given project, the specifier must indicate in the contract documents and purchase order that material must be melted and manufactured in the United States of America.

*When a project is subject to a metric design requirement, what shapes are available?*

ASTM A6M, the metric equivalent of ASTM A6, covers the metric series of structural shapes that is in use in the United States. Because it is a soft metric conversion, the metric series is physically identical to the inch-pound-unit shape series. The dimensions are given in millimeters (mm) with mass expressed in kilograms (kg); note that the mass must be multiplied by the acceleration of gravity  $9.81 \text{ m/s}^2$  to obtain kilonewtons (kN).

Note that a soft conversion is made by directly converting the U.S. customary unit value to a metric equivalent, for example, 1 in. equals 25.4 mm; conversely, a hard conversion is made by selecting new values in round metric increments, such as replacing 1 in. with 25 mm.

*To what ASTM Specifications are hollow structural sections (HSS) ordered?*

ASTM A500 grade B (although ASTM A500 grade C is increasingly very common) and A847 are appropriate when specifying square, rectangular, and round HSS. These specifications cover cold-formed production of both welded and seamless HSS; ASTM A847 offers atmospheric corrosion resistance properties similar to that of ASTM A588 for W-shapes. Pipe-size rounds (P, PX, and PXX) are also available in ASTM A53 grade B material.

## Other General Information

*Color combinations are commonly used to indicate various steel grades. Where are these color combinations established?*

Colors that identify the various grades of structural steel are currently established in ASTM A6/A6M-01 Section 18.6; for example, green and yellow for ASTM A572 grade 50 steel, blue and yellow for ASTM A588 steel and green and black for ASTM A992 steel. Note that it is anticipated that color coding will no longer be required in future versions of ASTM A6/A6M.



*Where are chemistry requirements for structural steel specified?*

Chemistry limitations and requirements are specified in the ASTM specifications for structural steels, such as ASTM A36, A572, A588, etc. Steel producers are required to report steel chemistry for each heat of steel produced on a CMTR (see the first question in the Ordering Steel section).

*Structurally, is there a difference between a 1/2 x 4 bar and a 1/2 x 4 plate?*

Structurally, none; furthermore, plate is becoming a universally applied term today. However, the historical classification system for such structural material would suggest the following physical difference: all four sides of a 1/2 x 4 bar would be rolled edges, i.e., the mill rolled it to that thickness and width. A 1/2 x 4 plate will have been cut from a 1/2-in. plate of greater width either by shearing or flame cutting.

*What are the common length limits on structural steel members as ordered from the mill?*

Common mill lengths range from 30 ft to 65 ft in 5-ft increments. However, because individual mill practices and standards vary, it is best to consult with individual mills directly. When steel is purchased from a warehouse, the selection of available lengths may be further limited. Additionally, the method of shipment may also limit the available length.

## GENERAL FABRICATION

### Material Identification and Traceability

*What is required for the identification of material?*

Identification means the ability to determine that the specified material grade and size is being used. An identification system is required in the 1999 AISC LRFD Specification Section M5.5: "The fabricator shall be able to demonstrate by a written procedure and by actual practice a method of material application and identification, visible at least through the "fit-up" operation, of the main structural elements of a shipping piece. The identification method shall be capable of verifying proper material application as it relates to:

1. Material specification designation
2. Heat number, if required
3. [CMTR] for special requirements [if required]."

*What is the difference between traceability and identification of material?*

Traceability means the ability to identify a specific piece of steel in a structure, throughout the life of the structure, and its specific CMTR. As such, traceability requirements are significantly more expensive than the identification requirements in the previous question. The owner should clearly understand the differences, limitations, and relative costs involved.

Traceability is not a requirement in the AISC LRFD Specification and, when required, must be clearly specified in the contract documents prior to the ordering of material. The following elements of traceability should be selected only as needed:

1. *Lot traceability vs. piece-mark traceability vs. piece traceability:* Lot traceability means that the materials used in a given project can be traced to the set of CMTR's for that project. Piece-mark traceability means that the heat number can be correlated for each piece mark, of which there can be many individual





pieces. Piece traceability means that the heat number can be correlated for each piece, which effectively demand separate piece marks for each piece.

Each of these three successive levels of traceability adds significant costs. Piece traceability, the most expensive option, is necessary only in critical applications, such as the construction of a nuclear power facility. Piece-mark traceability is often specified for main members in bridges. Lot identification is most common in other applications where traceability is required.

2. *Main-material traceability vs. all-material traceability:* Main-material traceability means that beams, columns, braces, and other main structural members are traced as specified above. All-material traceability means that connection and detail materials are also traced as specified above.

All-material traceability, the more expensive option, is necessary only in critical applications, such as the construction of a nuclear power facility. In other cases, main-material traceability is sufficient, when traceability is a requirement.

3. *Consumables traceability* means that lot numbers for consumables such as bolts, welding electrodes, and paint can be traced. This is necessary only in critical applications, such as the construction of a nuclear power facility.
4. *Required record retention* defines the level of detail required in documenting traceability (who, what, when, where, how, etc.).
5. *Fool-proof record retention vs. fraud-proof record retention:* Fool-proof record retention means internal verification of records. Fraud-proof record retention means external certification of records. Fraud-proof record retention is necessary only in critical applications, such as the construction of a nuclear power facility. In other cases, foolproof record retention is sufficient, when traceability is a requirement.

#### *How does a fabricator maintain traceability, when it is required?*

Each heat of steel produced by the mill is tested for chemical content and mechanical properties and the results are recorded on a CMTR, which is provided to and maintained in the records of the fabricator. Each piece that is rolled from this heat is then labeled with an identification mark that relates to the corresponding CMTR. The fabricator applies an identification mark to each piece. Because this piece mark remains with the piece throughout the fabrication and erection process, the material is traceable back to the CMTR for that individual piece.

Many connecting elements and similar fittings are too small to accommodate the marks to identify the piece from which they were cut. Additionally, such items are commonly made from stock materials with marks that may have inadvertently been abraded or lost during years of storage. In such cases, the fabricator provides written certification that the stock material meets the contract requirements.

Manufacturers of consumables such as bolts, welding electrodes and paint provide documentation as to the content and specification compliance of their products. This documentation is provided to and maintained in the records of the fabricator. The packaging in which the products are shipped is referenced to this documentation.

In some cases, the fabricator may purchase materials through a warehouse. When this is the case, the warehouse must transmit the necessary documentation from the manufacturer to the fabricator.

## **Cutting and Finishing Steel**

### *What methods are available for cutting steel and what is the corresponding range of utility for each?*

The following methods are commonly used to cut steel:



1. Friction sawing, which is performed with a high-speed rotary blade, is commonly used by steel producers and is limited only by machine size. This cutting method, however, is no longer commonly used in fabrication shops.
2. Cold sawing, whether by rotary saw, hack saw, or band saw, is limited only by machine size.
3. Oxygen-acetylene (and related fuel) flame cutting, which can be mechanically or hand-guided, is commonly used for general cutting and edge preparation operations, such as coping, beveling, notching, etc.; its utility is virtually unlimited.
4. Plasma cutting, which is mechanically guided, is generally useful for cutting plate of up to 3/4-in. thickness.
5. Laser cutting, which is mechanically guided, is generally useful for cutting plate; thickness limitations vary.
6. Shearing, which is performed with mechanical presses, is generally useful for cutting plates and angles and is limited only by machine size and capacity.

Additional minor material removal and finishing may also be accomplished by one of the methods listed in the next question.

*What methods are commonly used to provide finished surfaces, when required?*

Some of the cutting methods in the previous question result in surfaces that are finished without further treatment. When this is not the case, the following methods are commonly used to provide finished surfaces:

1. Milling, which is commonly used to bring members to their required length and end finish.
2. Face machining, which can be used to finish large areas to exact dimensions.
3. Planing.
4. Grinding, which is commonly used for edge preparation, including treatment of flame-cut edges, removal of burrs, etc. when required.

*Can the end of a column, as received from the rolling mill, be considered to be a finished surface?*

Yes, provided the mill cut is at right angles to the column axis and meets the surface roughness requirements in ASME B46.1.

*Is it commonly necessary to mill bearing surfaces after sawing?*

No. As stated in the 1999 AISC LRFD Specification Section M2.6, "compression joints which depend on contact bearing ... shall have the bearing surfaces of individually fabricated pieces prepared by milling, sawing, or other suitable means." The 2000 AISC *Code of Standard Practice* Section 6.2.2 Commentary states that "Most cutting processes, including friction sawing and cold sawing, and milling processes meet a surface roughness limitation of 500 per [ASME B46.1]." Cold-sawing equipment produces cuts that are more than satisfactory.

*What constitutes acceptable thermal cutting practice?*

Structural steel preferably should be thermally cut by mechanically guided means. However, mechanically guided cutting may not be feasible in some cases, such as the cutting of copes, blocks, holes for other than bolt holes, and similar cuts. Accordingly, hand-guided thermal cutting should be allowed as an alternative. Regardless, thermally cut surfaces must meet the appropriate roughness limitations as summarized in the next question.



*What are the appropriate roughness limitations for thermally cut edges?*

Inadvertent notches or gouges of varying magnitude may occur in thermally cut edges, depending upon the cleanliness of the material surface, the adjustment and manipulation of the cutting head, and various other factors. When thermally cut edges are prepared for the deposition of weld metal, the 1999 AISC LRFD Specification Section M2.2 and AWS D1.1-2000 Section 5.15.1.1 provide acceptance criteria that consider the effect of discontinuities that are generally parallel to the applied stress on the soundness of welded joints. Additionally, correction methods for defects of various magnitudes are stipulated therein. When thermally cut edges are to remain unwelded, the following surface condition guidelines are recommended:

1. If subjected to a calculated tensile stress parallel to the edge, edges should, in general, have a surface roughness value not greater than 1,000 as defined in ASME B46.1.
2. Mechanically guided thermally cut edges not subjected to a calculated tensile stress should have a surface roughness value not greater than 2,000 as defined in ASME B46.1.
3. Hand-guided thermally cut edges not subjected to a calculated tensile stress should have a roughness not greater than 1/16 in.
4. All thermally cut edges should be free of notches (defined as a V-shaped indentation or hollow) and reasonably free of gouges (defined as a groove or cavity having a curved shape). Occasional gouges not more than 3/16-in. deep are permitted.

Gouges greater than 3/16-in. deep and all notches should be repaired as indicated in the next question.

*When surface roughness for thermally cut edged does not meet the limitations in the previous question, how is the surface repaired?*

Roughness exceeding the criteria in the previous question and notches not more than 3/16-in. deep should be removed by machining or grinding and fairing-in at a slope not to exceed 1:2½. The repair of notches or gouges greater than 3/16-in. deep by welding should be permitted. The following criteria are recommended:

1. The discontinuity should be suitably prepared for good welding.
2. Low-hydrogen electrodes not exceeding 5/32-in. diameter should be used.
3. Other applicable welding requirements of AWS D1.1 should be observed.
4. The repair should be made flush with the adjacent surface with good workmanship.
5. The repair should be inspected to assure soundness.

*To what profile must re-entrant corners, such as corners of beam copes, be shaped?*

Re-entrant corners should provide a smooth transition between adjacent surfaces, but generally need not be cut exactly to a circular profile. The recommendation in the 3<sup>rd</sup> Edition AISC LRFD Manual (Part 9) is that an approximate minimum radius of 1/2 in. is acceptable. However, the primary emphasis should be that square-cut corners and corners with significantly smaller radii do not provide the smooth transition that is required. From the 1999 AISC LRFD Specification Section J1.6, it is acceptable to provide radius transitions by drilling (or hole sawing) with common-diameter drill sizes (not less than 3/4 in.) as suggested in the 1999 LRFD Specification Commentary Figure C-J1.2.

When the corner of a cope has been square-cut, a common solution is to flame-cut additional material at the corner to provide a smooth transition as illustrated in Figure 1. Note that the sides of the cope need not meet the radius transition tangentially. Any notches that occur at re-entrant corners should be repaired as indicated in the previous section, "Cutting and Finishing Steel".



## Use of Heat in Fabrication

*Is it permissible to use controlled heat to straighten, curve, or camber structural steel shapes?*

Yes. AWS D1.1-2000 Section 5.26.2 permits heat-straightening of members that are distorted by welding and stipulates rules for this procedure. These rules are equally applicable for all heat straightening or curving. Furthermore, the 1999 AISC LRFD Specification Section M2.1 and a discussion in the 3<sup>rd</sup> Edition AISC LRFD Manual (Part 2), provide a sound basis for the use of controlled heat to straighten, curve, camber, and form structural steel. The proper control of heat application generally involves the use of rosebud tips on torches to disperse the applied flame and temperature indicating crayons or similar devices to monitor the induced temperature.

*Is it permissible to accelerate cooling of structural steel after the application of controlled heat?*

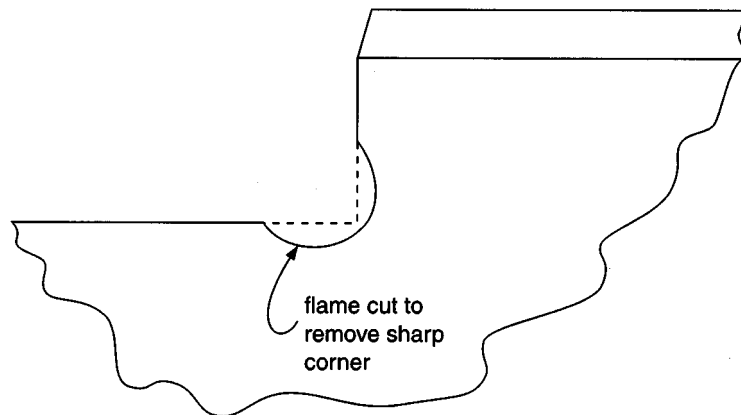
Yes, provided heated steel for Cyclically Loaded Structures is first allowed to cool ambiently to 600° Fahrenheit. Because the maximum temperature permitted by the 1999 AISC LRFD Specification Section M2.1 for heating operations is below any critical metallurgical temperature for the material being heated, the use of compressed air, water mist, or a combination thereof should be permitted to accelerate the final cooling of the heated. For members to be used in cyclically loaded structures (i.e., where fatigue and toughness are design issues) it is recommended that such accelerated cooling not begin until the temperature has dropped below 600° Fahrenheit. This limitation is more historical than technical in nature. As a fair balance between the desires of the fabricator and the concerns of the owner, it provides an added safeguard to prevent the abuse of excessive cooling and undesirable residual stresses should accepted procedures not be strictly monitored.

## Bolt Holes

*What are the acceptable methods for making bolt holes?*

Acceptable methods for making bolt holes include:

1. Punching
2. Sub-punching and reaming
3. Drilling
4. Hole sawing
5. Flame piercing and reaming
6. Flame cutting, subject to surface quality requirements as discussed in the next question.



**Figure 1.** Correction of square-cut copes.

*What variation in profile is generally acceptable for bolt holes?*

The slightly conical hole that naturally results from punching operations is acceptable, as noted in Table 3.1 of the 2000 RCSC Specification. The width of slotted holes that are produced by flame-cutting, or a combination of punching or drilling and flame-cutting should generally be not more than 1/32-in. greater than the nominal width except that gouges not more than 1/16-in. deep are permitted. In Statically Loaded Structures, the flame-cut surface need not be ground smooth; for Cyclically Loaded Structures, the flame-cut surface must be ground smooth.



*Must burrs be removed in bolted connections?*

From the 2000 RCSC Specification Section 3.4, "Burrs that extend 1/16 in. or less above the surface are permitted to remain on the faying surfaces of snug-tightened joints...[and pretensioned joints]. Burrs that extend over 1/16 in. above the surface shall be removed from all joints. Burrs that would prevent solid seating of the connected plies prior to the pretensioning of slip-critical joints ... shall be removed." From RCSC Bolt Bulletin No. 5, "... burrs are not detrimental to the performance of bearing connections. [In slip-critical connections] if burrs are so small that they are flattened during the snugging, it is not necessary that they be removed." It is further stated therein that larger burrs can remain if extra care is taken in the bolt installation process to achieve the proper bolt tension.

## Correction of Fabrication Errors

*Must fabrication errors always be repaired?*

No. Because the human element is involved in all phases of structural steel fabrication, material inadvertently may be cut to the wrong length, holes may be misplaced, parts may be located incorrectly, or notches or gouges may occur. However, many such errors or deviations need not be altered or repaired and are acceptable without change or penalty to the structure or its end use. Furthermore, some repair work may be more detrimental, as would that which creates higher residual stresses. In general, the SER should evaluate the deviation and whether it would be detrimental to the end use of the product.

In some cases, repair will be required and can usually be made so that the member will meet all performance criteria. Corrective measures to meet the requirements of shop drawings and specifications may generally be made by the fabricator during the normal course of fabrication, using qualified personnel and procedures that meet AISC and AWS specifications. Such action is considered to be a part of the fabricator's quality control program and should not require either notification of, or approval from, the owner or SER. However, in cases where major work is involved (cutting or removal of welded members from a welded assembly, modification of design, deviation from critical dimensions, etc.), the SER must be consulted and a plan of corrective action agreed upon.

*What repair is appropriate for material that is cut too short?*

When material is short of the minimum required length, welded splices or deposited weld metal, when applied with appropriate welding procedures and specified material, should be permitted with the approval of the SER.

*What repair is appropriate for mislocated bolt holes?*

Generally, mislocated fastener holes are not detrimental to the strength of a member if the remaining effective net section is adequate for the loads. As such, they may be left open, filled with bolts, or plug welded in accordance with AWS D1.1-2000 Section 5.26.5 with the approval of the SER. Ultrasonic inspection is not generally required for plug-welded fastener holes. Alternatively, if a bolt hole is mislocated by a small amount, say less than a bolt diameter, it is often possible to adjust the connection material to accommodate the error.

*What repair is required when a minor member mislocation occurs?*

When detail parts are placed in error, minor mislocations should be investigated to determine if relocation is necessary. When relocation is necessary, such as when dimensions are critical, the error is major, or the incorrectly placed part is visually unacceptable under an AESS requirement, the incorrectly placed part should be removed. For a welded detail, flame cutting, gouging, chipping, grinding, or machining may be required. Care should be taken to avoid damage to the main material of the associated member. The surface of the main material should be ground smooth and repaired, if necessary.



*What is "moderate reaming" as indicated in the 2000 AISC Code of Standard Practice Section 7.14?*

During the course of erection, it occasionally becomes necessary to ream holes so fasteners can be installed without damage to the threads, resulting in a hole that is larger than normal or elongated. The hole types recognized by the AISC and RCSC Specifications are standard, oversized, short-slotted, and long-slotted, with nominal dimensions as given in the 1999 AISC LRFD Specification Table J3.3. From the 2000 AISC *Code of Standard Practice* Section 7.14 Commentary, "the term "moderate" refers to the amount of reaming, grinding, welding or cutting that must be done on the project as a whole, not the amount that is required at an individual location. It is not intended to address limitations on the amount of material that is removed by reaming at an individual bolt hole, for example, which is limited by the bolt-hole size and tolerance requirements in the AISC and RCSC Specifications." Note that reamed holes must meet the provisions for minimum spacing and minimum edge distance in the 1999 AISC LRFD Specification Sections J3.3 and J3.4, respectively.

When more major misalignments occur, it is indicated in the 2000 AISC *Code of Standard Practice* Section 7.14 that they are "... promptly reported to the [owner] and the fabricator by the erector, to enable the responsible entity to either correct the error or approve the most efficient and economical method of correction to be used by others."

## Other General Information

*What precautions are required when cold bending material with sheared or flame-cut edges?*

When cold bending plates or performing other operations involving cold bending and a sheared or flame-cut edge, care must be taken to preclude the initiation of cracks at the edge. Minimum inside radii for cold bending plates of various steel grades are indicated in AISC 3<sup>rd</sup> Edition LRFD Manual Table 10-12 (Part 10). It is indicated in the corresponding text therein that the tabular values may have to be increased when bend lines are parallel to the direction of final rolling or longer than 36 in. Additionally, the Manual states that "Flame-cut edges of hardenable steels should be machined or softened by heat treatment. Nicks should be ground out and sharp corners should be rounded."

*What are the common length limits on fabricated structural steel members?*

The maximum length of a fabricated assembly is primarily limited by shipping and erectability concerns, such as overall length and total weight. However, because individual practices and capabilities vary, it is best to consult with the fabricator directly.

The common solution to a member length concern is a splice, which may be necessary and/or desirable for fabrication, shipping, and/or erectability considerations. When approved by the SER, fabricator-initiated splices in members are acceptable.

*Common steel items, such as metal deck and open-web steel joists, are not considered to be structural steel in the 2000 AISC Code of Standard Practice. Why?*

Even though items such as metal deck and open-web steel joists may be provided by the structural steel fabricator, they are not considered to be structural steel because they are neither manufactured nor fabricated by the structural steel fabricator. As such they are listed in Section 2.2 as "other steel or metal items". Items that are normally part of the fabricator's work are listed as structural steel items in Section 2.1.



## FABRICATION AND ERECTION TOLERANCES

### Member Cross-sectional Tolerances

*Can out-of-tolerance mill material be adjusted by the fabricator so that it conforms to the appropriate tolerances?*

Sometimes. Infrequently, material is discovered after delivery to be beyond mill tolerances. When material received from the rolling mill does not conform to the requirements of ASTM A6/A6M or more restrictive tolerances that are specified in the contract documents, the fabricator can use controlled heating, mechanical straightening, or a combination of both methods, consistent with manufacturer recommendations, to adjust cross-section, flatness, straightness, camber, and/or sweep.

*What is the tolerance on depth for built-up girders and trusses?*

The appropriate tolerances for the welded cross-section are specified in AWS D1.1-2000 Section 5.23. However, at bolted splices for such members, AWS D1.1-2000 Section 5.23 is silent on this subject. AISC recommends that the permissible deviations for girder depth in AWS D1.1-2000 Section 5.23.9 be applied to depth at bolted splices. Any differences within the prescribed tolerances at such joints should be taken up, if necessary, by shimming.

*What is the flatness tolerance for webs of built-up girders?*

For members in Statically Loaded Structures, web flatness does not affect the structural integrity of a girder because it primarily resists shear. Accordingly, neither the AISC LRFD Specification nor the AISC *Code of Standard Practice* includes a limitation on the out-of-flatness of girder webs. Such a tolerance is specified for welded plate girders, however, in AWS D1.1-2000 Section 5.23.6.2.

Shrinkage of web-to-flange welds and/or welds that attach stiffeners to the web can create operational difficulties in girder webs, particular those that are less than 5/16-in. thick. Accordingly, the dimensional tolerance for deviation from flatness of a girder web less than 5/16-in. thick, with or without stiffeners, in Statically Loaded Structures should be determined as the larger of 1/2-in. or the value determined in AWS D1.1-2000 Section 5.23.6.2. In Cyclically Loaded Structures, the value in AWS D1.1-2000 Section 5.23.6.3 should be observed. If architectural considerations require a more restrictive flatness tolerance, it should be specified in the contract documents. In all cases, the web thickness specified should be adequate to minimize such distortion.

### Member Straightness Tolerances

*How are the permissible deviations from straightness described in "Cross-sectional and Straightness Tolerances" accounted for in fabrication and erection?*

In most cases, deviations from true straightness and dimension of individual members (within the tolerances specified in ASTM A6/A6M) are compensated for during erection by the relative flexibility of the individual members compared to that of the overall structural steel frame they comprise. In some structures using heavy, rigid cross-sections, however, the stiffness of the member may preclude any adjustment of out-of-straightness that, although within acceptable limits, can prevent tight fit-up of connections. This situation is most likely to occur with multi-story building columns and may cause difficulty in erecting the floor framing members.

Although normal detailing practices may compensate in part for this problem, special shop layout practices are essential for heavy, rigid framing. A straight theoretical working line should be established between member ends as defined by the 2000 AISC *Code of Standard Practice* Section 7.13(c).



*What tolerance is applicable for the camber ordinate when beam camber is specified?*

As indicated in 2000 AISC *Code of Standard Practice* Section 6.4.4, for members less than 50-ft long, the camber tolerance is minus zero/plus 1/2-in; an additional 1/8 in. per each additional 10 ft of length (or fraction thereof) is allowed for lengths in excess of 50 ft. An exception is also included: members received from the rolling mill with 75 percent of the specified camber require no further cambering. Furthermore it is specified that camber be inspected in the fabricator's shop in an unstressed condition.

*What is the tolerance on sweep for curved girders?*

Permissible variations in sweep for horizontally curved welded plate girders are specified in AWS D1.1-2000 Section 5.23.5. However, because the method of measurement for this sweep dimension is not defined, the tolerance is sometimes misapplied. The permissible variation specified is the deviation of the theoretical mid-ordinate from a chord through the ends of a single fabricated girder section.

If it is required to hold the ordinate of additional points along the beam within a certain tolerance, these requirements should be specified in the contract documents. Note, however, that most girders have sufficient lateral flexibility to easily permit the attachment of diaphragms, cross-frames, lateral bracing, etc., without damaging the structural member or its attachment.

*What is the tolerance on twist of welded box members?*

As stated in AWS D1.1-2000 Section 5.23.11.4, "...[the tolerance on] twist of box members ... shall be individually determined and mutually agreed upon by the contractor and the owner with proper regard for erection requirements." In the absence of a specified tolerance, an attempt is sometimes made to apply the provisions of ASTM A500 or ASTM A6/A6M. However, the provisions of these material specifications should not be applied to fabricated box members.

In an unspliced member, the necessary tolerance on twist is generally a matter of serviceability or aesthetics. In a member that will be spliced, twist must be kept within limits that will allow safe and uncomplicated erection. Shop assembly of the entire member by the fabricator may be necessary to accomplish this. It is recommended that the fabricator and erector mutually agree on the means and methods necessary to achieve installation of an acceptable member in the completed structure (see the first question under "Other General Information"). Connection details for fabricated box members should accommodate twist in the completed member.

In any case, the required twist tolerance should be specified in the contract documents. Note, however, because of high torsional strength and stiffness, correction of twist in a closed box or similar shape is nearly impossible and carries the potential for damage. If the actual twist of a fabricated member exceeds a specified tolerance, whether to attempt correction should be a case-by-case decision made by the SER.

## Element Location Tolerances

*Is a tolerance on hole or hole pattern location specified in the 2000 AISC Code of Standard Practice?*

No. Neither the  $\pm 1/16$ -in. tolerance, where applicable, on overall length of members framed to other steel parts, nor the 1/16-in. clearance on size of standard holes, should be construed as implying that the tolerance  $\pm 1/16$  in. also applies either to the maximum tolerance on hole location within a pattern of holes or to the position of intermediate connections.

*What is the tolerance on location of intermediate and longitudinal stiffeners?*

When intermediate stiffeners are spaced at a distance that is approximately equal to the girder depth, weld shrinkage up to 3/8 in. in a 100-ft-long girder is not uncommon. Furthermore, thermal expansion or contraction in a





like length of girder due to a temperature differential of 50° Fahrenheit can cause a change in length of approximately 3/8 in. In view of these and other factors, there is a need for a tolerance on the location of longitudinal stiffeners. Because AWS D1.1-2000 Section 5.23 is silent on this subject, AISC recommends the following criteria:

1. Intermediate stiffeners may deviate from their theoretical location  $\pm 2$  in. as measured from the girder end.
2. Diaphragm and other connection stiffeners may deviate from their theoretical location by no more than twice the thickness of the stiffener.
3. Longitudinal stiffeners may deviate from their theoretical location by a distance equal to 1 percent of the girder depth.
4. If longitudinal stiffeners are interrupted by vertical stiffeners, the ends should not be offset by more than half the thickness of the longitudinal stiffeners.

*When forces are to be transferred by contact bearing, is a gap allowed between the contact surfaces?*

From the 1999 AISC LRFD Specification Section M4.4, "Lack of contact bearing not exceeding a gap of 1/16 in. (2 mm), regardless of the type of splice used (partial-point-penetration groove welded or bolted), is permitted." If the gap exceeds 1/16 in., but is less than 1/4 in., and an engineering investigation shows that the actual area in contact (within 1/16 in.) is adequate to transfer the load, then the gap is acceptable. Otherwise, per the 1999 AISC LRFD Specification Section M4.4, the gap must be packed with non-tapered steel shims. Similarly, a tolerance of 1/16 in. for bearing stiffeners is allowed in AWS D1.1-2000 Section 5.23.11.1. Such a gap would presumably be closed under load, bringing the stiffener into full contact bearing.

## Erection Tolerances

*How do individual member deviations impact the alignment and erected position of the overall structural steel frame?*

In many cases, individual member deviations that exceed established tolerances will have no adverse effect on the overall structural steel frame. However, in other instances, individual member deviations may accumulate and cause the overall structural steel frame to substantially exceed the overall permissible tolerances for plumbness, level, and line. It is essential that the effect of individual member tolerances on the overall structural steel frame be recognized and accounted for with practical detailing and fabrication techniques that permit compliance with overall tolerances.

## Other General Information

*How are tolerances determined if they are not addressed in the applicable standards?*

The fabrication and erection tolerances in the AISC LRFD Specification for Structural Steel Buildings, the AISC *Code of Standard Practice for Steel Buildings and Bridges*, AWS D1.1, and other existing specifications and codes have evolved over nearly three-quarters of a century. Although these standards generally present a workable format for the fabricator and erector, they tend to address individual members, rather than the role of individual members in the completed structure.

Tolerances for assemblies, such as those on shop-assembled bents, frames, platforms, pairs of girders, etc., are not covered by any code or standard. AWS D1.1 Section 5.23.11.4 states that "... other dimensional tolerances



of members not covered by [Section] 5.23 shall be individually determined and mutually agreed upon by the contractor and the owner with proper regard for erection requirements." This practice is recommended in all cases. The agreed upon tolerances should account for the erection tolerances specified in the AISC *Code of Standard Practice*.

*If special or more restrictive tolerances are required for the overall structural steel frame, can they be met?*

Possibly, but at a higher cost. Special clearances or tolerances may be difficult or impossible to achieve because of considerations such as temperature change, fabrication and construction procedures, and erection stresses. When specified, such requirements must be identified in the contract documents. The additional cost of special or more restrictive tolerance requirements should be justified.

*How can the accumulation of mill, fabrication, and erection tolerances be economically addressed?*

While individual member tolerances are usually self-compensating and of minor significance in the overall structure, the possibility exists that these tolerances may accumulate and lead to misalignments that are difficult to correct in the field. As an example of the effect individual member tolerances may have on the total structure, consider the tolerances on columns and beams. Individual column and beam members are shown with their respective permissible tolerances in Figure 2. These tolerances come from several sources: permissible camber and sweep are specified in ASTM A6/A6M and AWS D1.1; permissible variation from detailed length for members framed to other steel parts is specified in the AISC *Code of Standard Practice*; mill tolerances on the cross-section

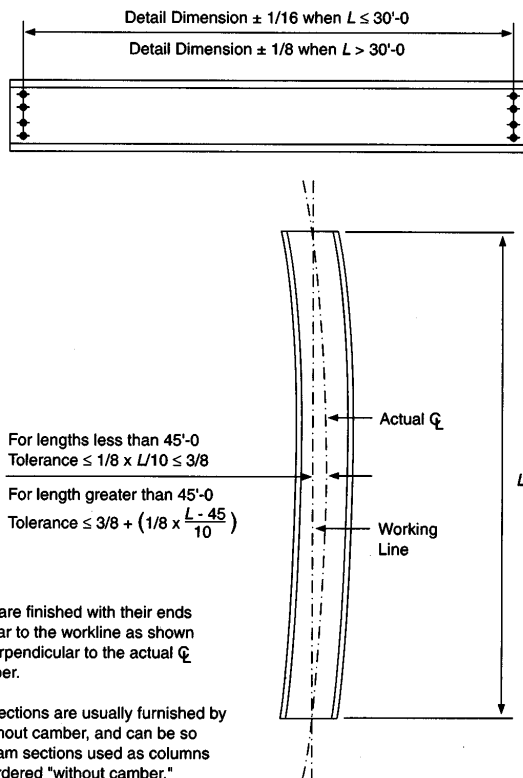


Figure 2. Beam and column fabrication tolerances

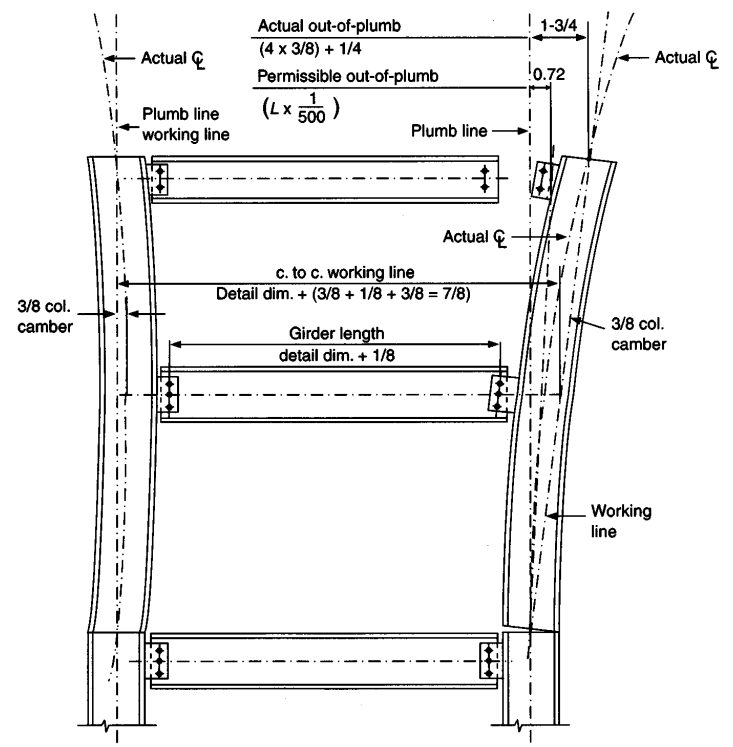


Figure 3. Possible (but unlikely) accumulation of tolerances when details are located from actual centerlines.



tion are illustrated in the 2000 AISC *Code of Standard Practice* Figure C-5.1. The foregoing example involves a possible but highly unlikely scenario.

A case where individual members fabricated within permissible tolerances could make it impossible to erect a heavy two-story column within the plumbness tolerance of  $\pm 1:500$  is illustrated in Figure 3. Although the condition shown would be unusual and represents the worst case with all member tolerances maximized and accumulated in one direction, it is evident that the accumulation of tolerances requires special consideration. Other possible examples include double-angle and end-plate connections to columns, attached shelf or spandrel angles, large plan dimensions in which many pieces line up, long bracing, expansion joints, and vertical systems such as stairs and multi-story wall panels. Deflections of cantilevered members and tolerance accumulation on complex framing systems involving a long series of connections before the load is in the column (causing accumulation of vertical tolerances) should also be considered.

Details for material supported by the steel framing must provide for the standard tolerances. For example, in buildings with large plans, it is beneficial to develop special details that accommodate the accumulation of fabrication tolerances. Note that building expansion joints cannot be adjusted to proper position without a provision for this adjustment.

The use of oversized holes, short-slotted holes, and long-slotted holes, provided a satisfactory method for achieving erection within tolerances as illustrated in Figures 4 and 5. Other satisfactory methods include the use of finger shims, shop layout to theoretical working lines, and recognition of tolerance accumulation in details for finishes, such as the curtain wall or stonework attachments.

## PAINING AND SURFACE PREPARATION

### Painting Requirements

*When must structural steel be painted?*

As stated in the 1999 AISC LRFD Specification Section M3.1, "Shop paint is not required unless specified by

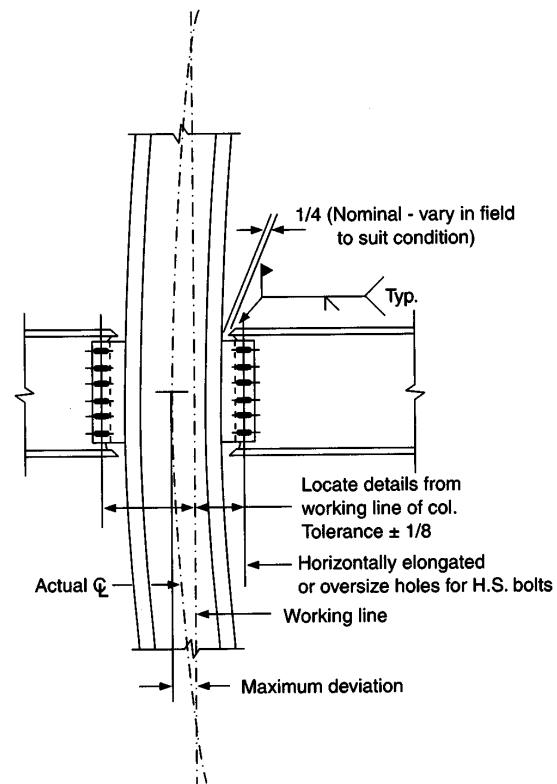


Figure 4. Adjustments for column curvature in beam-to-column connections.

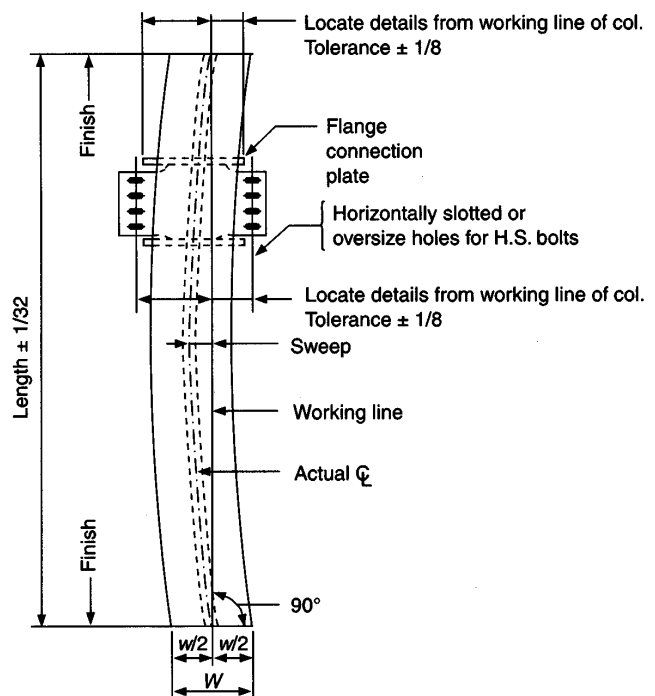


Figure 5. Adjustments for column sweep in beam-to-column connections.



the contract documents." Therefore, fabricated structural steel is left unpainted unless painting requirements are outlined in the contract documents.

In building structures, steel need not be primed or painted if it will be enclosed by building finish, coated with a contact-type fireproofing, or in contact with concrete. When enclosed, the steel is trapped in a controlled environment and the products required for corrosion are quickly exhausted. As indicated in the 1999 AISC LRFD Specification Commentary Section M3, "The surface condition of steel framing disclosed by the demolition of long-standing buildings has been found to be unchanged from the time of its erection, except at isolated spots where leakage may have occurred. Even in the presence of leakage, the shop [primer] coat is of minor influence (Bigos, Smith, Ball, and Foehl, 1954)." A similar situation exists when steel is fireproofed or in contact with concrete; in fact, paint is best omitted when steel is to be fireproofed because primer decreases its adhesion.

In exterior exposed applications, steel must be protected from corrosion by painting or other means. Likewise, steel must be protected from corrosion in special applications such as the corrosive environment of a paper processing plant or a structure with oceanfront exposure.

*When a paint system is required, how should it be selected?*

When paint is required, SSPC emphasizes the importance of the development of a total paint system. Among the primary considerations for this design decision by the owner, architect, or engineer are:

1. The end use of the member.
2. A realistic estimate of time and severity of exposure of each coat of paint.
3. An economic evaluation of the initial cost as compared to future maintenance cost.
4. A practical determination of the division between shop and field work and responsibilities.

*What should be included in contract documents when steel is to be painted?*

The following information should be specified when steel is to be painted:

1. The type and manufacturer of the specified paint (one alternative is the fabricator's standard shop primer)
2. The required level of surface preparation (expressed as an SSPC designation, i.e., SP2)
3. The desired dry film thickness

All technical data and directions for application of the specified paint, including required curing time, will be obtained by the fabricator from the paint manufacturer and need not be repeated in the contract documents, other than by reference.

*What paint system is implied by the general requirement of a "shop coat" or "paint"?*

When contract documents call for a "shop coat" or "paint" without specific identification of a paint system, this is interpreted as the fabricator's standard primer applied to a minimum thickness of 1 mil on steel that has been prepared in accordance with SSPC-SP2, with no conditional performance implied.

## Paint Film Thickness

*How is paint film thickness determined?*

The most commonly used paint-film-thickness measuring devices are wet-film thickness gauges and magnetic instruments for dry-film thickness measurement. When properly used during paint application, a wet film gauge is a direct-reading instrument that furnishes an immediate indication of thickness at a time when inadequacies



can be corrected, usually without the need for a full subsequent coat. The residual dry-film thickness can be determined from the wet-film thickness because the percent volume of solids in most paints is known. Alternatively, the correlation can be determined from actual dry-film thickness measurements taken at several areas. The readings of magnetic instruments for measurement of dry film thickness are often misinterpreted because they depend upon a number of variables such as initial calibration, type of cleaning, blast pattern profile, amount of mill scale remaining, and relative hardness of the paint film. However, when properly used, both wet-film and dry-film measurements provide an indication of the thickness of the paint over the peaks of the surface profile.

The primary measuring device for most types of paint should be the wet-film thickness gauge used during actual painting, with proper correlation to the percent volume of solids in the paint being applied. When magnetic instruments are used as a check on the dry film, SSPC-PA2 should be used for the dry-film thickness measurement.

*What frequency of paint film thickness inspection is appropriate?*

A sampling plan is defined in SSPC-A2 on the basis of the square footage of the structure being painted, which is useful for field painting applications. For sampling in shop painting applications, AISC recommends that 2 members be tested in every 25 tons or each shop layout of pieces to be painted. Any deficiencies in paint thickness or other specification requirements must be called to the attention of the fabricator by the owner/inspector at the time of completion of painting.

*Is a thicker paint film thickness than required acceptable?*

Yes. Because the specified paint thickness is usually a minimum requirement, greater thickness is permitted if it does not cause excessive mud cracking, runs, sags, or other defects of appearance or function.

## Surface Preparation Requirements

*What surface preparation should be specified for steel that is to remain unpainted?*

Steel that is to remain unpainted need only be cleaned of heavy deposits of oil and grease by appropriate means after fabrication. If other considerations dictate more stringent cleaning requirements, an SSPC-SP2 or other appropriate grade of cleaning should be specified in the contract documents.

*What level of surface preparation is specified for painted surfaces in the AISC Code of Standard Practice?*

As indicated in the 2000 AISC *Code of Standard Practice* Section 6.5.2, in the absence of other requirements in the contract documents, the fabricator hand cleans the steel of loose rust, loose mill scale, dirt, and other foreign matter, prior to painting, by means of wire brushing or by other methods elected by the fabricator, to meet the requirements of SSPC-SP2 (hand tool cleaning).

*Is it permissible for a fabricator to perform surface preparation beyond that called for in the contract documents?*

Yes, unless prohibited in the contract documents.

*What degree of cleaning is implied when surfaces are indicated to be "blast cleaned"?*

When blast-cleaned surfaces are specified in contract documents without identification of the desired degree of cleaning, SSPC-SP6 (commercial blast cleaning) is assumed.

*Where are surface cleaning requirements defined?*

The acceptance criteria for the degree of preparation are specified in SSPC-VIS-1, *The Pictorial Surface Preparation Standards for Painting Steel Surfaces*, for all SSPC surface preparation levels (SP1 through SP10).



*How is the blast profile inspected?*

When blast profile limits are specified, a Keane-Tator profile comparator, or equivalent, is acceptable for spot checking representative production blasting. Note that the specified profile range must be evaluated relative to the profile of the steel prior to blasting. Therefore, the total profile range will usually be greater than the range specified.

*When inspection of surface preparation is required, when should such inspection be made?*

When inspection is required in the contract documents, it should be made as soon as practical after the surface has been prepared. Inspection should be scheduled to avoid delays in the fabrication shop. Additionally, because the adequacy of surface preparation cannot be readily verified after painting, it should be inspected prior to application of the primer coat.

*What edge preparation is required for painting?*

Generally none, however, because a wet paint film is drawn by surface tension to a lesser thickness over sharp edges, some paint system specifications for severe exposures call for special edge treatments, such as grinding a light chamfer on sharp edges, striping corners or edges with shop paint to increase film thickness, or grinding corners to a minimum 1/16 in. radius. It should be noted that the term radius has precise meaning and an attempt is sometimes needlessly made to check corners with a radius template and require repairs at corners that do not conform closely to the specified radius. Because there is no significant difference in paint film thickness or life between a beveled corner and a corner that is ground to a small radius such treatment of edges is discouraged unless specified in the bid documents or in the paint manufacturer's directions. When required, edge treatment requirements should be limited to "breaking" the corner (eliminate the sharp 90 degree edge) with no reference to a specific dimension.

## **SSPC Surface Preparation Levels**

*What is the appropriate acceptance criteria for surface preparation in accordance with either SSPC-SP2 or SSPC-SP3?*

While the 2000 AISC *Code of Standard Practice* Section 6.5.2 calls for the removal of loose rust, loose mill scale, etc., the lack of specific definition (especially as to what constitutes "loose" mill scale) leaves the acceptance criteria subject to varying interpretation for both SSPC-SP2 (hand tool cleaning) and SSPC-SP3 (power tool cleaning). A mutually acceptable standard should be agreed upon by the owner so that the architect or engineer may knowledgeably design the paint system and the fabricator may realistically furnish the degree of surface preparation required.

*When SSPC-SP6 surface preparation is specified, what acceptance criteria should be applied?*

As stated in SSPC-SP6 (commercial blast cleaning) Section 2.2, "staining shall be limited to no more than 33 percent of each square inch of surface area and may consist of light shadows, slight streaks, or minor discolorations caused by stains of rust, stains of mill scale or stains of previously applied paint. Slight residues of rust and paint may also be left in the bottoms of pits if the original surface is pitted." Because specifying this requirement for each square inch is impractically restrictive, AISC recommends that this requirement be applied instead to the total surface area.



*When SSPC-SP10 surface preparation is specified, what acceptance criteria should be applied?*

As stated in SSPC-SP10 (near-white blast cleaning) Section 2.2, "staining shall be limited to no more than 5 percent of each square inch of surface area and may consist of light shadows, slight streaks, or minor discolorations caused by stains of rust, stains of mill scale or stains of previously applied paint." Because specifying this requirement for each square inch is impractically restrictive, AISC recommends that this requirement be applied instead to the total surface area.

## **Field Touch-up and Repair**

*How should contract documents address the problem of job-site mill-scale flaking?*

When SSPC-SP2 (hand tool cleaning) or SSPC-SP3 (power tool cleaning) surface preparation is specified and a short-exposure-life prime coat is subsequently applied, tight mill scale generally remains on the surface prior to shop painting. Likewise, tight mill scale may remain with SSPC-SP7 (brush-off blast cleaning) surface preparation. Depending upon the time of exposure, job-site conditions, and type of prime coat, some of this tight mill scale may loosen, resulting in mill-scale flaking. When required, provision should be made in the contract documents for an appropriate field touch-up and repair program. Traditionally, this work has been delegated to the painting contractor.

*Is the fabricator/erector responsible to clean steel after it has been erected?*

No. Shop-painted steel that is stored in the field pending erection should be kept free of the ground and so positioned as to minimize water-holding pockets, dust, mud, and other contamination of the paint film. However, because site conditions are frequently muddy, sandy, dusty, or a combination of all three, it may be impossible to store and handle the steel in such a way as to completely avoid accumulation of mud, dirt, or sand on the surface of the steel. When required, provision should be made in the contract documents for an appropriate cleaning program.

*Is the fabricator/erector responsible for field touch-up to the repair of blemishes and abrasions that result during handling and storage after painting?*

No. During storage, loading, transport, unloading, and erection, blemishes and abrasions caused by slings, chains, blocking, tie-downs, etc. occur in varying degrees and should be expected. Responsibility for field touch-up should be assigned in the contract documents. Traditionally, this work has been delegated to the painting contractor.

## **Other General Information**

*When welded surfaces are to be painted, what considerations are required?*

Some by-products of welding may be detrimental to paint performance and should be removed or neutralized prior to painting. Slag, chemical residue, and spatter compounds other than weld metal that are determined to be incompatible with the coating system should be removed or neutralized. Compatible residue, spatter compounds, and spattered weld metal that cannot be removed by hand scraping need not be removed provided that it is not detrimental to the performance of the structure or paint system.



## FIRE PROTECTION

### Fire Protection Systems

*What surface preparation should be specified for steel that is to be fireproofed?*

Steel that is designated to receive a field-applied contact-type fireproof coating should be shop cleaned of dirt, oil, grease, and loose mill scale by appropriate means. Rust, dirt, and other materials that might impair bond that accumulates between the time of fabrication and the time of application of the fireproof coating is not the responsibility of the fabricator/erector; such responsibility should be assigned in the contract documents.

### Fire Exposure

*What procedures should be followed when assessing steel that has been exposed to a fire?*

Dill (1960) concludes that, while exposure to fire will almost certainly cause warping and twisting of members, it does not inevitably follow that the strength of the steel is reduced. It is almost certain that any steel that has been heated hot enough to undergo damaging grain coarsening or that has been cooled rapidly enough to harden it will be so badly distorted that it would have no consideration for re-use anyway. This leads to the general statement that steel that has been through a fire but that can be made dimensionally re-usable by straightening with the methods that are available may be continued in use with full expectation of performance in accordance with its specified mechanical properties. Essentially then, the question is one of economics: if the steel can be straightened for less money than fabricating and installing a new piece, then that should be done.

Two possible exceptions to the above include quenched and tempered structural steels and high-strength fasteners. The mechanical properties of such heat-treated items may be affected by prolonged fire exposure and should be tested to determine the effects of the fire, if any.

Another reference is Council on Tall Buildings and Urban Habitat (1980).





## REFERENCES

American Institute of Steel Construction, 2001, *LRFD Manual of Steel Construction*, 3<sup>rd</sup> Edition, AISC, Chicago, IL.

American Institute of Steel Construction, 1999, *LRFD Specification for Structural Steel Buildings*, AISC, Chicago, IL.

American Institute of Steel Construction, 2000, *Code of Standard Practice for Steel Buildings and Bridges*, AISC, Chicago, IL.

American Society of Mechanical Engineers, 1995, ASME B46.1-1995, Surface Texture (Surface Roughness, Waviness, and Lay), ASME, New York, NY.

American Welding Society, 2000, *Structural Welding Code—Steel, D1.1*, AWS, Miami, FL.

Bigos, J., G.W. Smith, E.F. Ball, and P.J. Foehl, 1954, "Shop Paint and Painting Practice," *Proceedings of the 1954 AISC National Engineering Conference*, AISC, Chicago, IL.

Council on Tall Buildings and Urban Habitat, 1980, *Monograph on Planning and Design of Tall Buildings, Volume CL, Tall Building Criteria and Loading*, ASCE, Reston, VA.

Dill, F.H., 1960, "The Effects of Fire on Structural Steel," *Proceedings of the 1960 AISC National Engineering Conference*, AISC, Chicago, IL.

Research Council on Structural Connections, 2000, *Specification for Structural Joints Using ASTM A325 or A490 Bolts*, AISC, Chicago, IL.





---

# Code of Standard Practice for Steel Buildings and Bridges

---

March 7, 2000

Supersedes the June 10, 1992 AISC *Code of Standard Practice  
for Steel Buildings and Bridges* and all previous versions.

Prepared by the American Institute of Steel Construction, Inc. under  
the direction of the AISC Committee on the Code of Standard  
Practice and approved by the AISC Board of Directors.



**AMERICAN INSTITUTE OF STEEL CONSTRUCTION, INC.**  
One East Wacker Drive, Suite 3100, Chicago, Illinois 60601-2001



ii

Copyright © 2000

by

American Institute of Steel Construction, Inc.

All rights reserved. This book or any part thereof must not be reproduced in any form without the written permission of the publisher.

**The information presented in this publication has been prepared in accordance with recognized engineering principles and is for general information only. While it is believed to be accurate, this information should not be used or relied upon for any specific application without competent professional examination and verification of its accuracy, suitability and applicability by a licensed engineer, architect or other professional. The publication of the material contained herein is not intended as a representation or warranty on the part of the American Institute of Steel Construction, Inc. or of any other person named herein, that this information is suitable for any general or particular use or of freedom from infringement of any patent or patents. Anyone making use of this information assumes all liability arising from such use.**

**Caution must be exercised when relying upon other specifications and codes developed by other bodies and incorporated by reference herein since such material may be modified or amended from time to time subsequent to the printing of this edition. The American Institute of Steel Construction, Inc. bears no responsibility for such material other than to refer to it and incorporate it by reference at the time of the initial publication of this edition.**

Printed in the United States of America



## PREFACE

As in any industry, trade practices have developed among those that are involved in the design, purchase, fabrication and erection of structural steel. This Code provides a useful framework for a common understanding of the acceptable standards when contracting for structural steel. As such, it is useful for owners, architects, engineers, general contractors, construction managers, fabricators, steel detailers, erectors and others that are associated with construction in structural steel. Unless specific provisions to the contrary are contained in the contract documents, the existing trade practices that are contained herein are considered to be the standard custom and usage of the industry and are thereby incorporated into the relationships between the parties to a contract.

The Symbols and Glossary are an integral part of this Code. In many sections of this Code, a non-mandatory Commentary has been prepared to provide background and further explanation for the corresponding Code provisions. The user is encouraged to consult it.

Since the first edition of this Code was published in 1924, AISC has continuously surveyed the structural steel design community and construction industry to determine standard trade practices. Since then, this Code has been periodically updated to reflect new and changing technology and industry practices.

This edition is the fifth complete revision of this Code since it was first published. It is the result of the deliberations of a fair and balanced Committee, the membership of which included six structural engineers, two architects, one general contractor, seven fabricators, one steel detailer, three erectors and one attorney. The following major changes have been made in this revision:

- Commentary information, when available, has been placed immediately following its corresponding Code provisions.
- The use of the term “Owner” throughout this Code has been generally (but not completely) eliminated, where appropriate. Instead, one or both of the terms “Owner’s Designated Representative for Design” and “Owner’s Designated Representative for Construction” has been used.
- Both U.S. customary units and metric units have been provided. See Section 1.3.



iv

- Requirements for existing structures have been added to cover demolition and shoring, protection against damage, surveying or field dimensioning and hazardous materials.
- The classifications of materials in Section 2 have been editorially revised and expanded.
- Provisions for the resolution of discrepancies have been added in Section 3.3.
- Also in Section 3.3, the order of precedence of contract documents has been changed for simplicity and to reflect current practices.
- Provisions for fast-track project delivery have been added in Section 3.6.
- The responsibilities of the various entities involved in the shop and erection drawing approval process have been simplified and clarified in Section 4.
- Issues regarding the use of design drawings by the fabricator and/or the erector are now covered in Section 4.3.
- The permissible variation from theoretical curvature for a curved member is now covered in Section 6.4.2.
- Provisions have been added in Section 6.4.5 to cover permissible variations in camber for fabricated trusses.
- Section 6.5 has been editorially restructured and substantively modified to recognize that the majority of steel in building structures need not be primed or painted.
- Coverage of bearing devices has been revised: installation of bearing devices is now covered in Section 7.6 and grouting is covered in Section 7.7.
- Use of the terms self-supporting and non-self-supporting has been eliminated and replaced with the provisions for temporary support in Section 7.10.
- Provisions in Section 7.10.3 for the loads that must be considered during erection have been revised.
- The intent of the provisions that address the accumulation of mill tolerances and fabrication tolerances and their relationship to the erection tolerances has been clarified in Section 7.12.
- Quality-assurance provisions in Section 8 have been revised to recognize both the AISC Quality Certification program for fabricators and the AISC Erector Certification program.



- AESS requirements for welds have been clarified in Sections 10.2.5.
- AESS requirements for HSS weld seams have been added in Section 10.2.8.

In addition, many other changes have been made throughout this Code.

By the AISC Committee on the Code of Standard Practice,

Frank B. Wylie, III, Chairman  
Barry L. Barger, Vice Chairman  
Paul M. Brosnahan  
James R. Burdette, Jr.  
Richard B. Cook  
William B. Cooper  
William R. Davidson  
Joseph A. Free, Jr.  
Lawrence G. Griffis  
D. Kirk Harman  
James L. Larson  
William F. McEleney

Leonard R. Middleton  
James Mirgliotta  
Donald G. Moore  
Homer R. Peterson, II  
David B. Ratterman  
Rex D. Smith  
James A. Stori  
Thomas S. Tarpy, Jr.  
Michael J. Tylk  
Michael A. West  
Charles J. Carter, Secretary



## TABLE OF CONTENTS

<b>Glossary .....</b>	<b>ix</b>
<b>Section 1. General Provisions .....</b>	<b>1</b>
1.1. Scope .....	1
1.2. Referenced Specifications, Codes and Standards .....	1
1.3. Units .....	3
1.4. Design Criteria .....	3
1.5. Responsibility for Design .....	3
1.6. Patents and Copyrights .....	4
1.7. Existing Structures .....	4
1.8. Means, Methods and Safety of Erection .....	4
<b>Section 2. Classification of Materials .....</b>	<b>6</b>
2.1. Definition of Structural Steel .....	6
2.2. Other Steel, Iron or Metal Items .....	8
<b>Section 3. Design Drawings and Specifications .....</b>	<b>11</b>
3.1. Structural Design Drawings and Specifications .....	11
3.2. Architectural, Electrical and Mechanical Design Drawings and Specifications .....	16
3.3. Discrepancies .....	16
3.4. Legibility of Design Drawings .....	17
3.5. Revisions to the Design Drawings and Specifications .....	17
3.6. Fast-Track Project Delivery .....	18
<b>Section 4. Shop and Erection Drawings .....</b>	<b>20</b>
4.1. Owner Responsibility .....	20
4.2. Fabricator Responsibility .....	20
4.3. Use of CAD Files and/or Copies of Design Drawings .....	21
4.4. Approval .....	23
4.5. Shop and/or Erection Drawings Not Furnished by the Fabricator .....	25
<b>Section 5. Materials .....</b>	<b>26</b>
5.1. Mill Materials .....	26
5.2. Stock Materials .....	27





<b>Section 6. Shop Fabrication and Delivery .....</b>	<b>30</b>
6.1. Identification of Material .....	30
6.2. Preparation of Material .....	30
6.3. Fitting and Fastening .....	31
6.4. Fabrication Tolerances .....	32
6.5. Shop Cleaning and Painting .....	35
6.6. Marking and Shipping of Materials .....	38
6.7. Delivery of Materials .....	39
<b>Section 7. Erection .....</b>	<b>41</b>
7.1. Method of Erection .....	41
7.2. Job-Site Conditions .....	41
7.3. Foundations, Piers and Abutments .....	42
7.4. Building Lines and Bench Marks .....	42
7.5. Installation of Anchor Rods, Foundation Bolts and Other Embedded Items .....	42
7.6. Installation of Bearing Devices .....	44
7.7. Grouting .....	45
7.8. Field Connection Material .....	45
7.9. Loose Material .....	46
7.10. Temporary Support of Structural Steel Frames .....	46
7.11. Safety Protection .....	49
7.12. Structural Steel Frame Tolerances .....	51
7.13. Erection Tolerances .....	51
7.14. Correction of Errors .....	63
7.15. Cuts, Alterations and Holes for Other Trades .....	63
7.16. Handling and Storage .....	63
7.17. Field Painting .....	64
7.18. Final Cleaning Up .....	65
<b>Section 8. Quality Assurance .....</b>	<b>66</b>
8.1. General .....	66
8.2. Inspection of Mill Material.....	67
8.3. Non-Destructive Testing .....	67
8.4. Surface Preparation and Shop Painting Inspection .....	67
8.5. Independent Inspection .....	67



viii

<b>Section 9. Contracts .....</b>	<b>69</b>
9.1. Types of Contracts .....	69
9.2. Calculation of Weights .....	69
9.3. Revisions to the Contract Documents .....	71
9.4. Contract Price Adjustment .....	71
9.5. Scheduling .....	72
9.6. Terms of Payment .....	73
<b>Section 10. Architecturally Exposed Structural Steel .....</b>	<b>74</b>
10.1. General Requirements .....	74
10.2. Fabrication .....	74
10.3. Delivery of Materials .....	76
10.4. Erection .....	76



## GLOSSARY

The following terms are used in this Code. Where used, they are capitalized to alert the user that the term is defined in this Glossary.

*AASHTO.* American Association of State Highway and Transportation Officials.

*Adjustable Items.* See Section 7.13.1.3.

*AESS.* See Architecturally Exposed Structural Steel.

*AISC.* American Institute of Steel Construction, Inc.

*Anchor Bolt.* See Anchor Rod.

*Anchor Rod.* A mechanical device that is either cast or drilled and chemically adhered, grouted or wedged into concrete and/or masonry for the purpose of the subsequent attachment of Structural Steel.

*Anchor-Rod Group.* A set of Anchor Rods that receives a single fabricated Structural Steel shipping piece.

*ANSI.* American National Standards Institute.

*Architect.* The entity that is professionally qualified and duly licensed to perform architectural services.

*Architecturally Exposed Structural Steel.* See Section 10.

*AREMA.* American Railway Engineering and Maintenance of Way Association.

*ASME.* American Society of Mechanical Engineers.

*ASTM.* American Society for Testing and Materials.



x

*AWS.* American Welding Society.

*Bearing Devices.* Shop-attached base and bearing plates, loose base and bearing plates and leveling devices, such as leveling plates, leveling nuts and washers and leveling screws.

*CASE.* Council of American Structural Engineers.

*the Code, this Code.* This document, the *AISC Code of Standard Practice for Steel Buildings and Bridges* as adopted by the American Institute of Steel Construction, Inc.

*Connection.* An assembly of one or more joints that is used to transmit forces between two or more members and/or connection elements.

*Contract Documents.* The documents that define the responsibilities of the parties that are involved in bidding, fabricating and erecting Structural Steel. These documents normally include the Design Drawings, the Specifications and the contract.

*Design Drawings.* The graphic and pictorial portions of the Contract Documents showing the design, location and dimensions of the work. These documents generally include plans, elevations, sections, details, schedules, diagrams and notes.

*Embedment Drawings.* Drawings that show the location and placement of items that are installed to receive Structural Steel.

*EOR.* See Structural Engineer of Record.

*Engineer.* See Structural Engineer of Record.

*Engineer of Record.* See Structural Engineer of Record.

*Erection Bracing Drawings.* Drawings that are prepared by the Erector to illustrate the sequence of erection, any requirements for temporary supports and the requirements for raising, bolting and/or welding. These drawings are in addition to the Erection Drawings.



*Erection Drawings.* Field-installation or member-placement drawings that are prepared by the Fabricator to show the location and attachment of the individual shipping pieces.

*Erector.* The entity that is responsible for the erection of the Structural Steel.

*Established Column Line.* The actual field line that is most representative of the column centers along a line of columns placed using the dimensions shown in the structural Design Drawings, within the tolerances given in this Code.

*Fabricator.* The entity that is responsible for fabricating the Structural Steel.

*Hazardous Materials.* Components, compounds or devices that are either encountered during the performance of the contract work or incorporated into it containing substances that, notwithstanding the application of reasonable care, present a threat of harm to persons and/or the environment.

*Inspector.* The Owner's testing and inspection agency.

*MBMA.* Metal Building Manufacturers Association.

*Mill Material.* Steel mill products that are ordered expressly for the requirements of a specific project.

*Owner.* The entity that is identified as such in the Contract Documents.

*Owner's Designated Representative for Construction.* The Owner or the entity that is responsible to the Owner for the overall construction of the project, including its planning, quality and completion. This is usually the general contractor, the construction manager or similar authority at the job site.

*Owner's Designated Representative for Design.* The Owner or the entity



xii

that is responsible to the Owner for the overall structural design of the project, including the Structural Steel frame. This is usually the Structural Engineer of Record.

*Plans.* See Design Drawings.

*RCSC.* Research Council on Structural Connections.

*Released for Construction.* The term that describes the status of Contract Documents that are in such a condition that the Fabricator and the Erector can rely upon them for the performance of their work, including the ordering of material and the preparation of Shop and Erection Drawings.

*SER.* See Structural Engineer of Record.

*Shop Drawings.* Drawings of the individual Structural Steel shipping pieces that are to be produced in the fabrication shop.

*SJI.* Steel Joist Institute.

*Specifications.* The portion of the Contract Documents that consists of the written requirements for materials, standards and workmanship.

*SSPC.* SSPC: The Society for Protective Coatings, which was formerly known as the Steel Structures Painting Council.

*Standard Structural Shapes.* Hot-rolled W-, S-, M- and HP-shapes, channels and angles listed in ASTM A6/A6M; structural tees split from the hot-rolled W-, S- and M- shapes listed in ASTM A6/A6M; hollow structural sections produced to ASTM A500, A501, A618 or A847; and, steel pipe produced to ASTM A53/A53M.

*Steel Detailer.* The entity that produces the Shop and Erection Drawings.

*Structural Engineer of Record.* The licensed professional who is responsible for sealing the Contract Documents, which indicates that he or she has performed or supervised the analysis, design and document prepa-



ration for the structure and has knowledge of the load-carrying structural system.

*Structural Steel.* The elements of the structural frame as given in Section 2.1.

*Tier.* The Structural Steel framing defined by a column shipping piece.

*Weld Show-Through.* In Architecturally Exposed Structural Steel, visual indication of the presence of a weld or welds on the side of the member opposite the weld.



## NOTES





**CODE OF STANDARD PRACTICE  
FOR STEEL BUILDINGS AND BRIDGES**  
March 7, 2000

**SECTION 1. GENERAL PROVISIONS**

**1.1. Scope**

In the absence of specific instructions to the contrary in the Contract Documents, the trade practices that are defined in this Code shall govern the fabrication and erection of Structural Steel.

**Commentary:**

The practices defined in this Code are the commonly accepted standards of custom and usage for Structural Steel fabrication and erection, which generally represent the most efficient approach. This Code is not applicable to steel joists or metal building systems, which are addressed by SJI and MBMA, respectively.

**1.2. Referenced Specifications, Codes and Standards**

The following documents are referenced in this Code:

AASHTO Specification—The 1998 AASHTO *LRFD Bridge Design Specifications*, 2<sup>nd</sup> Edition, with interims up to and including 1999, or the 1996 AASHTO *Standard Specifications for Highway Bridges*, 16<sup>th</sup> Edition with interims up to and including 1999.

AISC Manual of Steel Construction—The AISC *Manual of Steel Construction, Volumes I and II, 2<sup>nd</sup> Edition LRFD or 9<sup>th</sup> Edition ASD*.

AISC Seismic Provisions—The AISC *Seismic Provisions for Structural Steel Buildings*, April 15, 1997 with *Seismic Provisions for Structural Steel Buildings (1997) Supplement No. 1*, February 15, 1999.

AISC Specification—The AISC *Specification for Structural Steel Buildings, 1999 LRFD or 1989 ASD*, as adopted by the American Institute of Steel Construction, Inc.

ANSI/ASME B46.1—ANSI/ASME B46.1-95, Surface Texture (Surface Roughness, Waviness and Lay).



- AREMA Specification—The 1999 AREMA *Manual for Railway Engineering, Volume II—Structures, Chapter 15*.
- ASTM A6/A6M—98, *Specification for General Requirements for Rolled Structural Steel Bars, Plates, Shapes, and Sheet Piling*.
- ASTM A53/A53M—99b, *Specification for Pipe, Steel, Black and Hot-Dipped, Zinc-Coated, Welded and Seamless*.
- ASTM A325—97, *Specification for Structural Bolts, Steel, Heat Treated, 120/105 ksi Minimum Tensile Strength*.
- ASTM A325M—97, *Specification for High-Strength Bolts for Structural Steel Joints (Metric)*.
- ASTM A490—97, *Specification for Heat-Treated Steel Structural Bolts, 150 ksi Minimum Tensile Strength*.
- ASTMA490M—93, *Specification for High-Strength Steel Bolts, Classes 10.9 and 10.9.3, for Structural Steel Joints (Metric)*.
- ASTM A500—99, *Specification for Cold-Formed Welded and Seamless Carbon Steel Structural Tubing in Rounds and Shapes*. No metric equivalent exists.
- ASTM A501—99, *Specification for Hot-Formed Welded and Seamless Carbon Steel Structural Tubing*. No metric equivalent exists.
- ASTM A618—99, *Specification for Hot-Formed Welded and Seamless High-Strength Low-Alloy Structural Tubing*. No metric equivalent exists.
- ASTM A847—99a, *Specification for Cold-Formed Welded and Seamless High-Strength, Low-Alloy Structural Tubing with Improved Atmospheric Corrosion Resistance*. No metric equivalent exists.
- ASTM F1852/F1852M—98, *Specification for “Twist-Off” Type Tension Control Structural Bolt/Nut/Washer Assemblies, Steel, Heat Treated, 120/105 ksi Minimum Tensile Strength*.
- AWS D1.1—The AWS D1.1 *Structural Welding Code—Steel*, 1998.
- CASE Document 11—*An Agreement Between Structural Engineer of Record and Contractor for Transfer of Computer Aided Drafting (CAD) files on Electronic Media*, 1996
- CASE Document 962—*The National Practice Guidelines for the Structural Engineer of Record*, Third Edition, 1997.
- RCSC Specification—*The Specification for Structural Joints Using ASTM A325 or A490 Bolts, 1994 LRFD or 1994 ASD*.



SSPC SP2—SSPC *Surface Preparation Specification No. 2, Hand Tool Cleaning*, July 5, 1995.

SSPC SP6—SSPC *Surface Preparation Specification No. 6, Commercial Blast Cleaning*, September 15, 1994.

### 1.3. Units

In this Code, the values stated in either U.S. customary units or metric units shall be used. Each system shall be used independently of the other.

#### **Commentary:**

In this Code, dimensions, weights and other measures are given in U.S. customary units with rounded or rationalized metric-unit equivalents in brackets. Because the values stated in each system are not exact equivalents, the selective combination of values from each of the two systems is not permitted.

### 1.4. Design Criteria

For buildings, in the absence of other design criteria, the provisions in the AISC Specification shall govern the design of the Structural Steel. For bridges, in the absence of other design criteria, the provisions in the AASHTO Specification and AREMA Specification shall govern the design of the Structural Steel, as applicable.

### 1.5. Responsibility for Design

1.5.1. When the Owner's Designated Representative for Design provides the design, Design Drawings and Specifications, the Fabricator and the Erector are not responsible for the suitability, adequacy or building-code conformance of the design.

1.5.2. When the Owner enters into a direct contract with the Fabricator to both design and fabricate an entire, completed steel structure, the Fabricator shall be responsible for the suitability, adequacy and building-code conformance of the Structural Steel design. The Owner shall be responsible for the suitability, adequacy and building-code conformance of the non-Structural Steel arrangement and the performance criteria for the Structural Steel frame.



4

**1.6. Patents and Copyrights**

The entity or entities that are responsible for the specification and/or selection of proprietary structural designs shall secure all intellectual property rights necessary for the use of those designs.

**1.7. Existing Structures**

1.7.1. Demolition and shoring of any part of an existing structure are not within the scope of work that is provided by either the Fabricator or the Erector. Such demolition and shoring shall be performed in a timely manner so as not to interfere with or delay the work of the Fabricator and the Erector.

1.7.2. Protection of an existing structure and its contents and equipment, so as to prevent damage from normal erection processes, is not within the scope of work that is provided by either the Fabricator or the Erector. Such protection shall be performed in a timely manner so as not to interfere with or delay the work of the Fabricator or the Erector.

1.7.3. Surveying or field dimensioning of an existing structure is not within the scope of work that is provided by either the Fabricator or the Erector. Such surveying or field dimensioning, which is necessary for the completion of Shop and Erection Drawings and fabrication, shall be performed and furnished to the Fabricator in a timely manner so as not to interfere with or delay the work of the Fabricator or the Erector.

1.7.4. Abatement or removal of Hazardous Materials is not within the scope of work that is provided by either the Fabricator or the Erector. Such abatement or removal shall be performed in a timely manner so as not to interfere with or delay the work of the Fabricator and the Erector.

**1.8. Means, Methods and Safety of Erection**

1.8.1. The Erector shall be responsible for the means, methods and safety of erection of the Structural Steel frame.



- 1.8.2. The Structural Engineer of Record shall be responsible for the structural adequacy of the structure in the completed project. The Structural Engineer of Record shall not be responsible for the means, methods and safety of erection of the Structural Steel frame. See also Sections 3.1.4 and 7.10.



## SECTION 2. CLASSIFICATION OF MATERIALS

### 2.1. Definition of Structural Steel

Structural Steel shall consist of the elements of the structural frame that are shown and sized in the structural Design Drawings, essential to support the design loads and described as:

Anchor Rods that will receive Structural Steel.

Base plates.

Beams, including built-up beams, if made from Standard Structural Shapes and/or plates.

Bearing plates.

Bearings of steel for girders, trusses or bridges.

Bracing, if permanent.

Canopy framing, if made from Standard Structural Shapes and/or plates.

Columns, including built-up columns, if made from Standard Structural Shapes and/or plates.

Connection materials for framing Structural Steel to Structural Steel.

Crane stops, if made from Standard Structural Shapes and/or plates.

Door frames, if made from Standard Structural Shapes and/or plates and if part of the Structural Steel frame.

Edge angles and plates, if attached to the Structural Steel frame or steel (open-web) joists.

Embedded Structural Steel parts, other than bearing plates, that will receive Structural Steel.

Expansion joints, if attached to the Structural Steel frame.

Fasteners for connecting Structural Steel items: permanent shop bolts, nuts and washers; shop bolts, nuts and washers for shipment; field bolts, nuts and washers for permanent Connections; and, permanent pins.

Floor-opening frames, if made from Standard Structural Shapes and/or plates and attached to the Structural Steel frame or steel (open-web) joists.

Floor plates (checkered or plain), if attached to the Structural Steel frame.



Girders, including built-up girders, if made from Standard Structural Shapes and/or plates.  
Girts, if made from Standard Structural Shapes.  
Grillage beams and girders.  
Hangers, if made from Standard Structural Shapes, plates and/or rods and framing Structural Steel to Structural Steel.  
Leveling nuts and washers.  
Leveling plates.  
Leveling screws.  
Lintels, if attached to the Structural Steel frame.  
Marquee framing, if made from Standard Structural Shapes and/or plates.  
Machinery supports, if made from Standard Structural Shapes and/or plates and attached to the Structural Steel frame.  
Monorail elements, if made from Standard Structural Shapes and/or plates and attached to the Structural Steel frame.  
Posts, if part of the Structural Steel frame.  
Purlins, if made from Standard Structural Shapes.  
Relieving angles, if attached to the Structural Steel frame.  
Roof-opening frames, if made from Standard Structural Shapes and/or plates and attached to the Structural Steel frame or steel (open-web) joists.  
Roof-screen support frames, if made from Standard Structural Shapes.  
Sag rods, if part of the Structural Steel frame and connecting Structural Steel to Structural Steel.  
Shear stud connectors, if specified to be shop attached.  
Shims, if permanent.  
Struts, if permanent and part of the Structural Steel frame.  
Tie rods, if part of the Structural Steel frame.  
Trusses, if made from Standard Structural Shapes and/or built-up members.  
Wall-opening frames, if made from Standard Structural Shapes and/or plates and attached to the Structural Steel frame.  
Wedges, if permanent.

**Commentary:**

The Fabricator normally fabricates the items listed in Section 2.1.



8

Such items must be shown, sized and described in the structural Design Drawings. Bracing includes vertical bracing for resistance to wind and seismic load and structural stability, horizontal bracing for floor and roof systems and permanent stability bracing for components of the Structural Steel frame.

## 2.2. Other Steel, Iron or Metal Items

Structural Steel shall not include other steel, iron or metal items that are not generally described in Section 2.1, even where such items are shown in the structural Design Drawings or are attached to the Structural Steel frame. Other steel, iron or metal items include but are not limited to:

- Bearings, if non-steel.
- Cables for permanent bracing or suspension systems.
- Castings.
- Catwalks.
- Chutes.
- Cold-formed steel products.
- Cold-rolled steel products, except those that are specifically covered in the AISC Specification.
- Corner guards.
- Crane rails, splices, bolts and clamps.
- Crane stops, if not made from Standard Structural Shapes or plates.
- Door guards.
- Embedded steel parts, other than bearing plates, that do not receive Structural Steel or that are embedded in precast concrete.
- Expansion joints, if not attached to the Structural Steel frame.
- Flagpole support steel.
- Floor plates (checkered or plain), if not attached to the Structural Steel frame.
- Forgings.
- Gage-metal products.
- Grating.
- Handrail.
- Hangers, if not made from Standard Structural Shapes, plates





and/or rods or not framing Structural Steel to Structural Steel.

Hoppers.  
Items that are required for the assembly or erection of materials that are furnished by trades other than the Fabricator or Erector.

Ladders.

Lintels, if not attached to the Structural Steel frame.

Masonry anchors.

Miscellaneous metal.

Ornamental metal framing.

Pressure vessels.

Reinforcing steel for concrete or masonry.

Relieving angles, if not attached to the Structural Steel frame.

Roof screen support frames, if not made from Standard Structural Shapes.

Safety cages.

Shear stud connectors, if specified to be field installed.

Stacks.

Stairs.

Steel deck.

Steel (open-web) joists.

Steel joist girders.

Tanks.

Toe plates.

Trench or pit covers.

**Commentary:**

Section 2.2 includes many items that may be furnished by the Fabricator if contracted to do so by specific notation and detail in the Contract Documents. When such items are contracted to be provided by the Fabricator, coordination will normally be required between the Fabricator and other material suppliers and trades. The provisions in this Code are not intended to apply to items in Section 2.2.

In previous editions of this Code, provisions regarding who should normally furnish field-installed shear stud connectors and



10

cold-formed steel deck support angles were included in Section 7.8. These provisions have been eliminated since field-installed shear stud connectors and steel deck support angles are not defined as Structural Steel in this Code.



## SECTION 3. DESIGN DRAWINGS AND SPECIFICATIONS

### 3.1. Structural Design Drawings and Specifications

Unless otherwise indicated in the Contract Documents, the structural Design Drawings shall be based upon consideration of the design loads and forces to be resisted by the Structural Steel frame in the completed project.

The structural Design Drawings shall clearly show the work that is to be performed and shall give the following information with sufficient dimensions to accurately convey the quantity and nature of the Structural Steel to be fabricated:

- (a) The size, section, material grade and location of all members;
- (b) All geometry and working points necessary for layout;
- (c) Floor elevations;
- (d) Column centers and offsets;
- (e) The camber requirements for members; and,
- (f) The information that is required in Sections 3.1.1 through 3.1.6.

The Structural Steel Specification shall include any special requirements for the fabrication and erection of the Structural Steel. The structural Design Drawings, Specifications and addenda shall be numbered and dated for the purposes of identification.

#### **Commentary:**

Contract Documents vary greatly in complexity and completeness. Nonetheless, the Fabricator and the Erector must be able to rely upon the accuracy and completeness of the Contract Documents. This allows the Fabricator and the Erector to provide the Owner with bids that are adequate and complete. It also enables the preparation of the Shop and Erection Drawings, the ordering of materials and the timely fabrication and erection of shipping pieces.

In some cases, the Owner can benefit when reasonable latitude is allowed in the Contract Documents for alternatives that can reduce cost without compromising quality. However, critical requirements that are necessary to protect the Owner's interest, that



affect the integrity of the structure or that are necessary for the Fabricator and the Erector to proceed with their work must be included in the Contract Documents. Some examples of critical information include:

- Standard specifications and codes that govern Structural Steel design and construction, including bolting and welding.
- Material specifications.
- Special material requirements to be reported on the certified mill test reports.
- Welded-joint configuration.
- Weld-procedure qualification.
- Special requirements for work of other trades.
- Final disposition of backing bars and runoff tabs.
- Lateral bracing.
- Stability bracing.
- Connections or data for Connection selection and/or completion.
- Restrictions on Connection types.
- Column stiffeners (also known as continuity plates).
- Column web doubler plates.
- Bearing stiffeners on beams and girders.
- Web reinforcement.
- Openings for other trades.
- Surface preparation and shop painting requirements.
- Shop and field inspection requirements.
- Non-destructive testing requirements, including acceptance criteria.
- Special requirements on delivery.
- Special erection limitations.
- Identification of non-Structural Steel elements that interact with the Structural Steel frame to provide for the lateral stability of the Structural Steel frame (see Section 3.1.4).
- Column differential shortening information.
- Special fabrication and erection tolerances for AESS.
- Special pay-weight provisions.

3.1.1. Permanent bracing, column stiffeners, column web doubler plates,



bearing stiffeners in beams and girders, web reinforcement, openings for other trades and other special details, where required, shall be shown in sufficient detail in the structural Design Drawings so that the quantity, detailing and fabrication requirements for these items can be readily understood.

3.1.2. The Owner's Designated Representative for Design shall either show the complete design of the Connections in the structural Design Drawings or allow the Fabricator to select or complete the Connection details while preparing the Shop and Erection Drawings. When the Fabricator is allowed to select or complete the Connection details, the following information shall be provided in the structural Design Drawings:

- (a) Any restrictions on the types of Connections that are permitted;
- (b) Data concerning the loads, including shears, moments, axial forces and transfer forces, that are to be resisted by the individual members and their Connections, sufficient to allow the Fabricator to select or complete the Connection details while preparing the Shop and Erection Drawings;
- (c) Whether the data required in (b) is given at the service-load level or the factored-load level; and,
- (d) Whether LRFD or ASD is to be used in the selection or completion of Connection details.

When the Fabricator selects or completes the Connection details, the Fabricator shall utilize the requirements in the AISC Specification and the Contract Documents and submit the Connection details to the Owner's Designated Representative for Design for approval.

**Commentary:**

When the Owner's Designated Representative for Design shows the complete design of the Connections in the structural Design Drawings, the following information is included:

- (a) All weld sizes and lengths;
- (b) All bolt sizes, locations, quantities and grades;



- (c) All plate and angle sizes, thicknesses and dimensions; and,
- (d) All work point locations and related information.

The intent of this approach is that complete information necessary for Connection detailing, fabrication and erection is shown in the structural Design Drawings. The Steel Detailer will then be able to transfer this information to the Shop and Erection Drawings, applying it to the individual pieces being detailed.

When the Owner's Designated Representative for Design allows the Fabricator to select or complete the Connections, this is commonly done by referring to tables in the Contract Documents or in the AISC Manual of Steel Construction, or by schematically showing the types of Connections required in the structural Design Drawings. The Steel Detailer will then configure the Connections based upon the design loads and other information given in the structural Design Drawings. If the desired Connection is not covered in those tables, a detail of the "special" Connection should be contained in the structural Design Drawings. This detail should provide such information as weld sizes, plate thicknesses and quantities of bolts. However, there may be some geometry and dimensional information that the Steel Detailer must develop. The intent of this method is that the Steel Detailer will select the Connection materials and configuration from the referenced tables or complete the specific Connection configuration (i.e. dimensions, edge distances and bolt spacing) based upon the Connection details that are shown in the structural Design Drawings.

This method will require the skill of an experienced Steel Detailer, who is familiar with the AISC requirements for Connection configurations, capable and experienced in the use of the Connection tables in the AISC Manual of Steel Construction and capable of calculating dimensions and adapting a typical Connection detail to similar situations. Notations of loadings in the structural Design Drawings are only to facilitate selection of the Connections from the referenced tables. It is not the intent of this method that the Steel Detailer practice engineering.

If there are any restrictions as to the types of Connections to be used, particularly as it relates to simple shear Connections, it is required that these limitations be set forth in the structural Design



Drawings and Specifications. There are a variety of Connections available in the AISC Manual of Steel Construction for a given situation. Preference for a particular type will vary between Fabricators and Erectors. Stating these limitations, if any, in the structural Design Drawings and Specifications will help to avoid repeated changes to the Shop and Erection Drawings due to the selection of a Connection that is not acceptable to the Owner's Designated Representative for Design, thereby avoiding additional cost and/or delay for the redrawing of the Shop and Erection Drawings.

The structural Design Drawings must indicate the method of design used as LRFD or ASD. In order to conform to the spirit of the AISC Specification, the Connections must be selected using the same method and the corresponding references.

- 3.1.3. When leveling plates are to be furnished as part of the contract requirements, their locations and required thickness and sizes shall be specified in the Contract Documents.
- 3.1.4. When the Structural Steel frame, in the completely erected and fully connected state, requires interaction with non-Structural Steel elements (see Section 2) for strength and/or stability, those non-Structural Steel elements shall be identified in the Contract Documents as required in Section 7.10.

**Commentary:**

Examples of non-Structural Steel elements include diaphragms made of steel deck, diaphragms made of concrete on steel deck and masonry and/or concrete shear walls.

- 3.1.5. When camber is required, the magnitude, direction and location of camber shall be specified in the structural Design Drawings.

**Commentary:**

For cantilevers, the specified camber may be up or down, depending upon the framing and loading.

- 3.1.6. Specific members or portions thereof that are to be left unpainted



shall be identified in the Contract Documents. When shop painting is required, the painting requirements shall be specified in the Contract Documents, including the following information:

- (a) The identification of specific members or portions thereof to be painted;
- (b) The surface preparation that is required for these members;
- (c) The paint specifications and manufacturer's product identification that are required for these members; and,
- (d) The minimum dry-film shop-coat thickness that is required for these members.

**Commentary:**

Some members or portions thereof may be required to be left unpainted, such as those that will be in contact and acting compositely with concrete, or those that will receive spray-applied fire protection materials.

**3.2. Architectural, Electrical and Mechanical Design Drawings and Specifications**

All requirements for the quantities, sizes and locations of Structural Steel shall be shown or noted in the structural Design Drawings. The use of architectural, electrical and/or mechanical Design Drawings as a supplement to the structural Design Drawings is permitted for the purposes of defining detail configurations and construction information.

**3.3. Discrepancies**

When a discrepancy is discovered in the Contract Documents in the course of the Fabricator's work, the Fabricator shall promptly notify the Owner's Designated Representative for Construction so that the discrepancy can be resolved by the Owner's Designated Representative for Design. Such resolution shall be timely so as not to delay the Fabricator's work.

When discrepancies exist between the Design Drawings and Specifications, the Design Drawings shall govern. When discrepancies exist between scale dimensions in the Design Drawings and the figures written in them, the figures shall govern. When dis-





crepancies exist between the structural Design Drawings and the architectural, electrical or mechanical Design Drawings or Design Drawings for other trades, the structural Design Drawings shall govern.

**Commentary:**

While it is the Fabricator's responsibility to report any discrepancies that are discovered in the Contract Documents, it is not the Fabricator's responsibility to discover discrepancies, including those that are associated with the coordination of the various design disciplines. The quality of the Contract Documents is the responsibility of the entities that produce those documents.

**3.4. Legibility of Design Drawings**

Design Drawings shall be clearly legible and drawn to a scale that is not less than 1/8 in. to the foot [10 mm per 1 000 mm]. More complex information shall be drawn to a scale that is adequate to clearly convey the information.

**3.5. Revisions to the Design Drawings and Specifications**

Revisions to the Design Drawings and Specifications shall be made either by issuing new Design Drawings and Specifications or by re-issuing the existing Design Drawings and Specifications. In either case, all revisions, including revisions that are communicated through the annotation of Shop and/or Erection Drawings (see Section 4.4.2), shall be clearly and individually indicated in the Contract Documents. The Contract Documents shall be dated and identified by revision number. Each Design Drawing shall be identified by the same drawing number throughout the duration of the project, regardless of the revision. See also Section 9.3.

**Commentary:**

Revisions to the Design Drawings and Specifications can be made by issuing sketches and supplemental information separate from the Design Drawings and Specifications. These sketches and supplemental information become amendments to the Design Drawings and Specifications and are considered new Contract Documents. All sketches and supplemental information must be



uniquely identified with a number and date as the latest instructions until such time as they may be superseded by new information.

When revisions are made by revising and re-issuing the existing structural Design Drawings and/or Specifications, a unique revision number and date must be added to those documents to identify that information as the latest instructions until such time as they may be superseded by new information. The same unique drawing number must identify each Design Drawing throughout the duration of the project so that revisions can be properly tracked, thus avoiding confusion and miscommunication among the various entities involved in the project.

When revisions are communicated through the annotation of Shop or Erection Drawings or contractor submissions, such changes must be confirmed in writing by one of the aforementioned methods. This written confirmation is imperative to maintain control of the cost and schedule of a project and to avoid potential errors in fabrication.

### **3.6. Fast-Track Project Delivery**

When the fast-track project delivery system is selected, release of the structural Design Drawings and Specifications shall constitute a Release for Construction, regardless of the status of the architectural, electrical, mechanical and other interfacing designs and Contract Documents. Subsequent revisions, if any, shall be the responsibility of the Owner and shall be made in accordance with Sections 3.5 and 9.3.

#### **Commentary:**

The fast-track project delivery system generally provides for a condensed schedule for the design and construction of a project. Under this delivery system, the Owner elects to Release for Construction the structural Design Drawings and Specifications, which may be partially complete, at a time that may precede the completion of and coordination with architectural, mechanical, electrical and other design work and Contract Documents. The release of these structural Design Drawings and Specifications may also precede the release of the General Conditions and Division 1 Specifications.

Release of the structural Design Drawings and



Specifications to the Fabricator for ordering of material constitutes a Release for Construction. Accordingly, the Fabricator and the Erector may begin their work based upon those partially complete documents. As the architectural, mechanical, electrical and other design elements of the project are completed, revisions may be required in design and/or construction. Thus, when considering the fast-track project delivery system, the Owner should balance the potential benefits to the project schedule with the project cost contingency that may be required to allow for these subsequent revisions.



## SECTION 4. SHOP AND ERECTION DRAWINGS

### 4.1. Owner Responsibility

The Owner shall furnish, in a timely manner and in accordance with the Contract Documents, complete structural Design Drawings and Specifications that have been Released for Construction. Unless otherwise noted, Design Drawings that are provided as part of a contract bid package shall constitute authorization by the Owner that the Design Drawings are Released for Construction

#### **Commentary:**

When the Owner issues Released-for-Construction Design Drawings and Specifications, the Fabricator and the Erector rely on the fact that these are the Owner's requirements for the project. This release is required by the Fabricator prior to the ordering of material and the preparation and completion of Shop and Erection Drawings.

To ensure the orderly flow of material procurement, detailing, fabrication and erection activities, on phased construction projects, it is essential that designs are not continuously revised after they have been Released for Construction. In essence, once a portion of a design is Released for Construction, the essential elements of that design should be "frozen" to ensure adherence to the contract price and construction schedule. Alternatively, all parties should reach a common understanding of the effects of future changes, if any, as they affect scheduled deliveries and added costs.

### 4.2. Fabricator Responsibility

Except as provided in Section 4.5, the Fabricator shall produce Shop and Erection Drawings for the fabrication and erection of the Structural Steel and is responsible for the following:

- (a) The transfer of information from the Contract Documents into accurate and complete Shop and Erection Drawings; and,
- (b) The development of accurate, detailed dimensional information to provide for the fit-up of parts in the field.



When the Fabricator submits a request to change Connection details that are described in the Contract Documents, the Fabricator shall notify the Owner's Designated Representatives for Design and Construction in writing in advance of the submission of the Shop and Erection Drawings. The Owner's Designated Representative for Design shall review and approve or reject the request in a timely manner.

When requested to do so by the Owner's Designated Representative for Design, the Fabricator shall advise the Owner's Designated Representatives for Design and Construction of its schedule for the submittal of Shop and Erection Drawings so as to facilitate the timely flow of information between all parties.

**Commentary:**

As the Fabricator develops the detailed dimensional information for production of the Shop and Erection Drawings, there may be discrepancies, missing information or conflicts discovered in the Contract Documents. See Section 3.3.

When the Fabricator intends to make a submission of alternative Connection details to those shown in the Contract Documents, the Fabricator must notify the Owner's Designated Representatives for Design and Construction in advance. This will allow the parties involved to plan for the increased effort that may be required to review the alternative Connection details. In addition, the Owner will be able to evaluate the potential for cost savings and/or schedule improvements against the additional design cost for review of the alternative Connection details by the Owner's Designated Representative for Design. This evaluation by the Owner may result in the rejection of the alternative Connection details or acceptance of the submission for review based upon cost savings, schedule improvements and/or job efficiencies.

When the Fabricator provides a schedule for the submission of the Shop and Erection Drawings, it must be recognized that this schedule may be affected by revisions and the response time to requests for missing information or the resolution of discrepancies.

**4.3. Use of CAD Files and/or Copies of Design Drawings**

The Fabricator shall neither use nor reproduce any part of the



Design Drawings as part of the Shop or Erection Drawings without the written permission of the Owner's Designated Representative for Design. When CAD files or copies of the Design Drawings are made available for the Fabricator's use, the Fabricator shall accept this information under the following conditions:

- (a) All information contained in the CAD files or copies of the Design Drawings shall be considered instruments of service of the Owner's Designated Representative for Design and shall not be used for other projects, additions to the project or the completion of the project by others. CAD files and copies of the Design Drawings shall remain the property of the Owner's Designated Representative for Design and in no case shall the transfer of these CAD files or copies of the Design Drawings be considered a sale.
- (b) The CAD files or copies of the Design Drawings shall not be considered to be Contract Documents. In the event of a conflict between the Design Drawings and the CAD files or copies thereof, the Design Drawings shall govern;
- (c) The use of CAD files or copies of the Design Drawings shall not in any way obviate the Fabricator's responsibility for proper checking and coordination of dimensions, details, member sizes and fit-up and quantities of materials as required to facilitate the preparation of Shop and Erection Drawings that are complete and accurate as required in Section 4.2; and,
- (d) The Fabricator shall remove information that is not required for the fabrication or erection of the Structural Steel from the CAD files or copies of the Design Drawings.

**Commentary:**

With the advent of electronic media and the internet, electronic copies of Design Drawings are becoming readily available to the Fabricator. As a result, the Owner's Designated Representative for Design may have reduced control over the unauthorized use of the Design Drawings. There are many copyright and other legal issues to be considered.

The Owner's Designated Representative for Design may



choose to make CAD files or copies of the Design Drawings available to the Fabricator, and may charge a service or licensing fee for this convenience. In doing so, a carefully negotiated agreement should be established to set out the specific responsibilities of both parties in view of the liabilities involved for both parties. For a sample contract, see CASE Document 11.

The CAD files and/or copies of the Design Drawings are provided to the Fabricator for convenience only. The information therein should be adapted for use only in reference to the placement of Structural Steel members during erection. The Fabricator should treat this information as if it were fully produced by the Fabricator and undertake the same level of checking and quality assurance. When amendments or revisions are made to the Contract Documents, the Fabricator must update this reference material.

When CAD files or copies of the Design Drawings are provided to the Fabricator, they often contain other information, such as architectural backgrounds or references to other Contract Documents. This additional material should be removed when producing Shop and Erection Drawings to avoid the potential for confusion.

#### **4.4. Approval**

Except as provided in Section 4.5, the Shop and Erection Drawings shall be submitted to the Owner's Designated Representatives for Design and Construction for review and approval. These drawings shall be returned to the Fabricator within 14 calendar days. Approved Shop and Erection Drawings shall be individually annotated by the Owner's Designated Representatives for Design and Construction as either approved or approved subject to corrections noted. When so required, the Fabricator shall subsequently make the corrections noted and furnish corrected Shop and Erection Drawings to the Owner's Designated Representatives for Design and Construction.

#### **Commentary:**

As used in this Code, the 14-day allotment for the return of Shop and Erection Drawings is intended to represent the Fabricator's portal-to-portal time. The intent in this Code is that, in the absence



of information to the contrary in the Contract Documents, 14 days may be assumed for the purposes of bidding, contracting and scheduling. A submittal schedule is commonly used to facilitate the approval process.

- 4.4.1. Approval of the Shop and Erection Drawings, approval subject to corrections noted and similar approvals shall constitute the following:
- (a) Confirmation that the Fabricator has correctly interpreted the Contract Documents in the preparation of those submittals;
  - (b) Confirmation that the Owner's Designated Representative for Design has reviewed and approved the Connection details shown on the Shop and Erection Drawings and submitted in accordance with Section 3.1.2, if applicable; and,
  - (c) Release by the Owner's Designated Representatives for Design and Construction for the Fabricator to begin fabrication using the approved submittals.

Such approval shall not relieve the Fabricator of the responsibility for either the accuracy of the detailed dimensions in the Shop and Erection Drawings or the general fit-up of parts that are to be assembled in the field.

The Fabricator shall determine the fabrication schedule that is necessary to meet the requirements of the contract.

**Commentary:**

When considering the current language in this Section, the Committee sought language that would parallel the practices of CASE. In CASE Document 962, CASE indicates that when the design of some element of the primary structural system is left to someone other than the Structural Engineer of Record, "...such elements, including connections designed by others, should be reviewed by the Structural Engineer of Record. He [or she] should review such designs and details, accept or reject them and be responsible for their effects on the primary structural system." Historically, this Code has embraced this same concept.

From the inception of this Code, AISC and the industry in





general have recognized that only the Owner's Designated Representative for Design has all the information necessary to evaluate the total impact of Connection details on the overall structural design of the project. This authority has traditionally been exercised during the approval process for Shop and Erection Drawings. The Owner's Designated Representative for Design has thus retained responsibility for the adequacy and safety of the entire structure since at least the 1927 edition of this Code.

- 4.4.2. Unless otherwise noted, any additions, deletions or revisions that are indicated on the approved Shop and Erection Drawings shall constitute authorization by the Owner that the additions, deletions or revisions are Released for Construction. The Fabricator and the Erector shall promptly notify the Owner's Designated Representative for Construction when any direction or notation on the Shop or Erection Drawings or other information will result in an additional cost and/or a delay. See Sections 3.5 and 9.3.

**Commentary:**

When the Fabricator notifies the Owner's Designated Representative for Construction that a direction or notation on the Shop or Erection Drawings will result in an additional cost or a delay, it is then normally the responsibility of the Owner's Designated Representative for Construction to subsequently notify the Owner's Designated Representative for Design.

**4.5. Shop and/or Erection Drawings Not Furnished by the Fabricator**

When the Shop and Erection Drawings are not prepared by the Fabricator, but are furnished by others, they shall be delivered to the Fabricator in a timely manner. These Shop and Erection Drawings shall be prepared, insofar as is practical, in accordance with the shop fabrication and detailing standards of the Fabricator. The Fabricator shall neither be responsible for the completeness or accuracy of Shop and Erection Drawings so furnished, nor for the general fit-up of the members that are fabricated from them.



## SECTION 5. MATERIALS

### 5.1. Mill Materials

Unless otherwise noted in the Contract Documents, the Fabricator is permitted to order the materials that are necessary for fabrication when the Fabricator receives Contract Documents that have been Released for Construction.

**Commentary:**

The Fabricator may purchase materials in stock lengths, exact lengths or multiples of exact lengths to suit the dimensions shown in the structural Design Drawings. Such purchases will normally be job-specific in nature and may not be suitable for use on other projects or returned for full credit if subsequent design changes make these materials unsuitable for their originally intended use. The Fabricator should be paid for these materials upon delivery from the mill, subject to appropriate additional payment or credit if subsequent unanticipated modification or reorder is required. Purchasing materials to exact lengths is not considered fabrication.

- 5.1.1. Unless otherwise specified by means of special testing requirements in the Contract Documents, mill testing shall be limited to those tests that are required for the material in the ASTM specifications indicated in the Contract Documents. Certified mill test reports shall be furnished by the Fabricator if requested to do so by the Owner's Designated Representative for Design, either in the Contract Documents or in separate written instructions given to the Fabricator prior to ordering Mill Materials.

**Commentary:**

Mill tests are performed to demonstrate material conformance to ASTM specifications in accordance with the contract requirements.

- 5.1.2. When Mill Material does not satisfy ASTM A6/A6M tolerances for camber, profile, flatness or sweep, the Fabricator shall be permitted to perform corrective procedures, including the use of controlled heating and/or mechanical straightening, subject to the limitations in the AISC Specification.

**Commentary:**

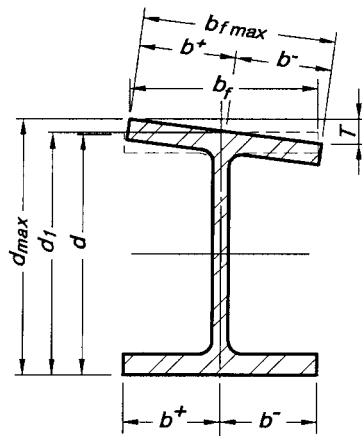
Mill dimensional tolerances are completely set forth in ASTM A6/A6M. Normal variations in the cross-sectional geometry of Standard Structural Shapes must be recognized by the designer, the Fabricator, the Steel Detailer and the Erector (for example, see Figure C-5.1). Such tolerances are mandatory because roll wear, thermal distortions of the hot cross-section immediately after leaving the forming rolls and differential cooling distortions that take place on the cooling beds are all unavoidable. Geometric perfection of the cross-section is not necessary for either structural or architectural reasons, if the tolerances are recognized and provided for.

ASTM A6/A6M also stipulates tolerances for straightness that are adequate for typical construction. However, these characteristics may be controlled or corrected to closer tolerances during the fabrication process when the added cost is justified by the special requirements for an atypical project.

- 5.1.3. When variations that exceed ASTM A6/A6M tolerances are discovered or occur after the receipt of Mill Material the Fabricator shall, at the Fabricator's option, be permitted to perform the ASTM A6/A6M corrective procedures for mill reconditioning of the surface of Structural Steel shapes and plates.
- 5.1.4. When special tolerances that are more restrictive than those in ASTM A6/A6M are required for Mill Materials, such special tolerances shall be specified in the Contract Documents. The Fabricator shall, at the Fabricator's option, be permitted to order material to ASTM A6/A6M tolerances and subsequently perform the corrective procedures described in Sections 5.1.2 and 5.1.3.

**5.2. Stock Materials**

- 5.2.1. If used for structural purposes, materials that are taken from stock by the Fabricator shall be of a quality that is at least equal to that required in the ASTM specifications indicated in the Contract Documents.
- 5.2.2. Certified mill test reports shall be accepted as sufficient record of the quality of materials taken from stock by the Fabricator. The

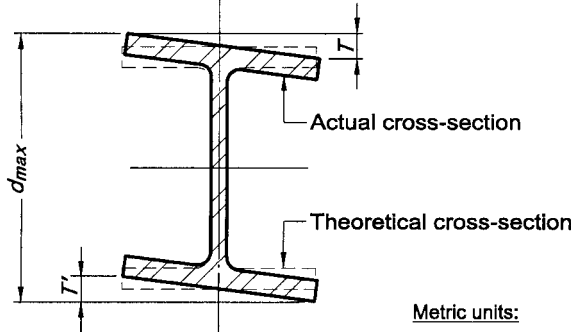


**U.S. customary units:**

Flange-tilt tolerances:  
 $T + T' = 1/4"$  in. for  $d \leq 12$  in.  
 $= 5/16"$  in. for  $d > 12$  in.

Actual depth with tolerances:  
 $d_1 = d$  plus or minus  $1/8$  in. (typ.)  
 $d_{max} = d + T + T'$

Actual flange width with tolerances:  
 $b^+ = 1/2 b_f$  plus or minus  $3/16$  in.  
 $b^- = 1/2 b_f$  minus or plus  $3/16$  in.  
 $b_{max} = b_f$  plus  $1/4$  in. or minus  $3/16$  in.



**Metric units:**

Flange-tilt tolerances:  
 $T + T' = 6$  mm for  $d \leq 300$  mm  
 $= 8$  mm for  $d > 300$  mm

Actual depth with tolerances:  
 $d_1 = d$  plus or minus 3 mm  
 $d_{max} = d + T + T'$

Actual flange width with tolerances:  
 $b^+ = 1/2 b_f$  plus or minus 5 mm  
 $b^- = 1/2 b_f$  minus or plus 5 mm  
 $b_{max} = b_f$  plus 6 mm or minus 5 mm

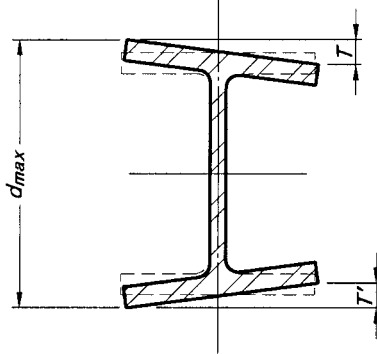


Figure C-5.1. Mill tolerances on the cross-section of a W-shape.



Fabricator shall review and retain the certified mill test reports that cover such stock materials. However, the Fabricator need not maintain records that identify individual pieces of stock material against individual certified mill test reports, provided the Fabricator purchases stock materials that meet the requirements for material grade and quality in the applicable ASTM specifications.

- 5.2.3. Stock materials that are purchased under no particular specification, under a specification that is less rigorous than the applicable ASTM specifications or without certified mill test reports or other recognized test reports shall not be used without the approval of the Owner's Designated Representative for Design.



## **SECTION 6. SHOP FABRICATION AND DELIVERY**

### **6.1. Identification of Material**

6.1.1. Material that is ordered to special requirements shall be marked by the supplier as specified in ASTM A6/A6M Section 12 prior to delivery to the Fabricator's shop or other point of use. Material that is ordered to special requirements, but not so marked by the supplier, shall not be used until:

- (a) Its identification is established by means of testing in accordance with the applicable ASTM specifications; and,
- (b) A Fabricator's identification mark, as described in Section 6.1.2 and 6.1.3, has been applied.

6.1.2. During fabrication, up to the point of assembling members, each piece of material that is ordered to special requirements shall carry a Fabricator's identification mark or an original supplier's identification mark. The Fabricator's identification mark shall be in accordance with the Fabricator's established identification system, which shall be on record and available prior to the start of fabrication for the information of the Owner's Designated Representative for Construction, the building-code authority and the Inspector.

6.1.3. Members that are made of material that is ordered to special requirements shall not be given the same assembling or erection mark as members made of other material, even if they are of identical dimensions and detail.

### **6.2. Preparation of Material**

6.2.1. The thermal cutting of Structural Steel by hand-guided or mechanically guided means is permitted.

6.2.2. Surfaces that are specified as "finished" in the Contract Documents shall have a roughness height value measured in accordance with ANSI/ASME B46.1 that is equal to or less than 500. The use of any fabricating technique that produces such a finish is permitted.

**Commentary:**

Most cutting processes, including friction sawing and cold sawing, and milling processes meet a surface roughness limitation of 500 per ANSI/ASME B46.1.

**6.3. Fitting and Fastening**

- 6.3.1. Projecting elements of Connection materials need not be straightened in the connecting plane, subject to the limitations in the AISC Specification.
- 6.3.2. Backing bars and runoff tabs shall be used in accordance with AWS D1.1 as required to produce sound welds. The Fabricator or Erector need not remove backing bars or runoff tabs unless such removal is specified in the Contract Documents. When the removal of backing bars is specified in the Contract Documents, such removal shall meet the requirements in AWS D1.1. When the removal of runoff tabs is specified in the Contract Documents, hand flame-cutting close to the edge of the finished member with no further finishing is permitted, unless other finishing is specified in the Contract Documents.

**Commentary:**

In most cases, the treatment of backing bars and runoff tabs is left to the discretion of the Owner's Designated Representative for Design. In some cases, treatment beyond the basic cases described in this Section may be required. As one example, special treatment is required for backing bars and runoff tabs in beam-to-column moment Connections when the requirements in the AISC Seismic Provisions must be met. In all cases, the Owner's Designated Representative for Design should specify the required treatments in the Contract Documents.

- 6.3.3. Unless otherwise noted in the Shop Drawings, high-strength bolts for shop-attached Connection material shall be installed in the shop in accordance with the requirements in the AISC Specification.



#### 6.4. Fabrication Tolerances

The tolerances on Structural Steel fabrication shall be in accordance with the requirements in Section 6.4.1 through 6.4.6.

##### **Commentary:**

Fabrication tolerances are stipulated in several specifications and codes, each applicable to a specialized area of construction. Basic fabrication tolerances are stipulated in this Section. For Architecturally Exposed Structural Steel, see Section 10. Other specifications and codes are also commonly incorporated by reference in the Contract Documents, such as the AISC Specification, the RCSC Specification, AWS D1.1 and the AASHTO Specification.

- 6.4.1. For members that have both ends finished (see Section 6.2.2) for contact bearing, the variation in the overall length shall be equal to or less than 1/32 in. [1 mm]. For other members that frame to other Structural Steel elements, the variation in the detailed length shall be as follows:
- (a) For members that are equal to or less than 30 ft [9 000 mm] in length, the variation shall be equal to or less than 1/16 in. [2 mm].
  - (b) For members that are greater than 30 ft [9 000 mm] in length, the variation shall be equal to or less than 1/8 in. [3 mm].
- 6.4.2. For straight structural members other than compression members, whether of a single Standard Structural Shape or built-up, the variation in straightness shall be equal to or less than that specified for wide-flange shapes in ASTM A6/A6M, except when a smaller variation in straightness is specified in the Contract Documents. For straight compression members, whether of a Standard Structural Shape or built-up, the variation in straightness shall be equal to or less than 1/1000 of the axial length between points that are to be laterally supported. For curved structural members, the variation from the theoretical curvature shall be equal to or less than the variation in sweep that is specified for an equivalent straight member of the same straight length in ASTM A6/A6M.





In all cases, completed members shall be free of twists, bends and open joints. Sharp kinks or bends shall be cause for rejection.

- 6.4.3. For beams and trusses that are detailed without specified camber, the member shall be fabricated so that, after erection, any incidental camber due to rolling or shop fabrication is upward.
- 6.4.4. For beams that are specified in the Contract Documents with camber, beams received by the Fabricator with 75% of the specified camber shall require no further cambering. Otherwise, the variation in camber shall be as follows:
- (a) For beams that are equal to or less than 50 ft [15 000 mm] in length, the variation shall be equal to or less than minus zero / plus 1/2 in. [13 mm].
  - (b) For beams that are greater than 50 ft [15 000 mm] in length, the variation shall be equal to or less than minus zero / plus 1/2 in. plus 1/8 in. for each 10 ft or fraction thereof [13 mm plus 3 mm for each 3 000 mm or fraction thereof] in excess of 50 ft [15 000 mm] in length.

For the purpose of inspection, camber shall be measured in the Fabricator's shop in the unstressed condition.

**Commentary:**

There is no known way to inspect beam camber after the beam is received in the field because of factors that include:

- (a) The release of stresses in members over time and in varying applications;
- (b) The effects of the dead weight of the member;
- (c) The restraint caused by the end Connections in the erected state; and,
- (d) The effects of additional dead load that may ultimately be intended to be applied, if any.

Therefore, inspection of the Fabricator's work on beam camber



must be done in the fabrication shop in the unstressed condition.

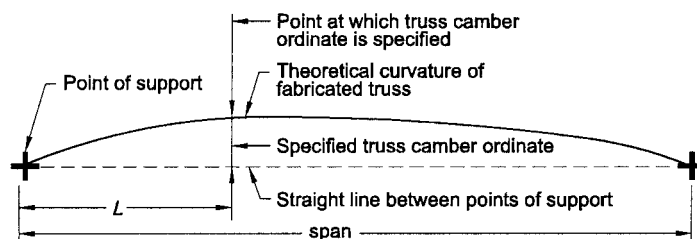
- 6.4.5. For fabricated trusses that are specified in the Contract Documents with camber, the variation in camber at each specified camber point shall be equal to or less than plus or minus  $1/800$  of the distance to that point from the nearest point of support. For the purpose of inspection, camber shall be measured in the Fabricator's shop in the unstressed condition.

**Commentary:**

There is no known way to inspect truss camber after the truss is received in the field because of factors that include:

- (a) The effects of the dead weight of the member;
- (b) The restraint caused by the truss Connections in the erected state; and,
- (c) The effects of additional dead load that may ultimately be intended to be applied, if any.

Therefore, inspection of the Fabricator's work on truss camber must be done in the fabrication shop in the unstressed condition. See Figure C-6.1.



Taking  $L$  as the distance from the point at which truss camber is specified to the closer point of support, in. [mm], the tolerance on truss camber at that point is calculated as  $L/800$ .  $L$  must be equal to or less than one-half the span.

*Figure C-6.1. Illustration of the tolerance on camber for fabricated trusses with specified camber.*



- 6.4.6. When permissible variations in the depths of beams and girders result in abrupt changes in depth at splices, such deviations shall be accounted for as follows:
- (a) For splices with bolted joints, the variations in depth shall be taken up with filler plates; and,
  - (b) For splices with welded joints, the weld profile shall be adjusted to conform to the variations in depth, the required cross-section of weld shall be provided and the slope of the weld surface shall meet the requirements in AWS D1.1.

**6.5. Shop Cleaning and Painting (see also Section 3.1.6)**

Structural Steel that does not require shop paint shall be cleaned of oil and grease with solvent cleaners, and of dirt and other foreign material by sweeping with a fiber brush or other suitable means. For Structural Steel that is required to be shop painted, the requirements in Sections 6.5.1 through 6.5.4 shall apply.

**Commentary:**

Extended exposure of unpainted Structural Steel that has been cleaned for the subsequent application of fire protection materials can be detrimental to the fabricated product. Most levels of cleaning require the removal of all loose mill scale, but permit some amount of tightly adhering mill scale. When a piece of Structural Steel that has been cleaned to an acceptable level is left exposed to a normal environment, moisture can penetrate behind the scale, and some “lifting” of the scale by the oxidation process is to be expected. Cleanup of “lifted” mill scale is not the responsibility of the Fabricator, but is to be assigned by contract requirement to an appropriate contractor.

Section 6.5.4 of this Code is not applicable to weathering steel, for which special cleaning specifications are always required in the Contract Documents.

- 6.5.1. The Fabricator is not responsible for deterioration of the shop coat that may result from exposure to ordinary atmospheric conditions or corrosive conditions that are more severe than ordinary atmos-



pheric conditions.

**Commentary:**

The shop coat of paint is the prime coat of the protective system. It is intended as protection for only a short period of exposure in ordinary atmospheric conditions, and is considered a temporary and provisional coating.

- 6.5.2. Unless otherwise specified in the Contract Documents, the Fabricator shall, as a minimum, hand clean the Structural Steel of loose rust, loose mill scale, dirt and other foreign matter, prior to painting, by means of wire brushing or by other methods elected by the Fabricator, to meet the requirements of SSPC-SP2. If the Fabricator's workmanship on surface preparation is to be inspected by the Inspector, such inspection shall be performed in a timely manner prior to the application of the shop coat.

**Commentary:**

The selection of a paint system is a design decision involving many factors including:

- (a) The Owner's preference;
- (b) The service life of the structure;
- (c) The severity of environmental exposure;
- (d) The cost of both initial application and future renewals; and,
- (e) The compatibility of the various components that comprise the paint system (surface preparation, shop coat and subsequent coats).

Because the inspection of shop painting must be concerned with workmanship at each stage of the operation, the Fabricator provides notice of the schedule of operations and affords the Inspector access to the work site. Inspection must then be coordinated with that schedule so as to avoid delay of the scheduled operations.

Acceptance of the prepared surface must be made prior to the application of the shop coat because the degree of surface preparation cannot be readily verified after painting. Time delay



between surface preparation and the application of the shop coat can result in unacceptable deterioration of a properly prepared surface, necessitating a repetition of surface preparation. This is especially true with blast-cleaned surfaces. Therefore, to avoid potential deterioration of the surface, it is assumed that surface preparation is accepted unless it is inspected and rejected prior to the scheduled application of the shop coat.

The shop coat in any paint system is designed to maximize the wetting and adherence characteristics of the paint, usually at the expense of its weathering capabilities. Deterioration of the shop coat normally begins immediately after exposure to the elements and worsens as the duration of exposure is extended. Consequently, extended exposure of the shop coat will likely lead to its deterioration and may necessitate repair, possibly including the repetition of surface preparation and shop coat application in limited areas. With the introduction of high-performance paint systems, avoiding delay in the application of the shop coat has become more critical. High-performance paint systems generally require a greater degree of surface preparation, as well as early application of weathering protection for the shop coat.

Since the Fabricator does not control the selection of the paint system, the compatibility of the various components of the total paint system, or the length of exposure of the shop coat, the Fabricator cannot guarantee the performance of the shop coat or any other part of the system. Instead, the Fabricator is responsible only for accomplishing the specified surface preparation and for applying the shop coat (or coats) in accordance with the Contract Documents.

This Section stipulates that the Structural Steel is to be cleaned to meet the requirements in SSPC-SP2. This stipulation is not intended to represent an exclusive cleaning level, but rather the level of surface preparation that will be furnished unless otherwise specified in the Contract Documents if the Structural Steel is to be painted.

Further information regarding shop painting is available in *A Guide to Shop Painting of Structural Steel*, published jointly by SSPC and AISC.



38

- 6.5.3. Unless otherwise specified in the Contract Documents, paint shall be applied by brushing, spraying, rolling, flow coating, dipping or other suitable means, at the election of the Fabricator. When the term “shop coat”, “shop paint” or other equivalent term is used with no paint system specified, the Fabricator’s standard shop paint shall be applied to a minimum dry-film thickness of one mil [25  $\mu\text{m}$ ].
- 6.5.4. Touch-up of abrasions caused by handling after painting shall be the responsibility of the contractor that performs touch-up in the field or field painting.

**Commentary:**

Touch-up in the field and field painting are not normally part of the Fabricator’s or the Erector’s contract.

**6.6. Marking and Shipping of Materials**

- 6.6.1. Unless otherwise specified in the Contract Documents, erection marks shall be applied to the Structural Steel members by painting or other suitable means.
- 6.6.2. Bolt assemblies and loose bolts, nuts and washers shall be shipped in separate closed containers according to length and diameter, as applicable. Pins and other small parts and packages of bolts, nuts and washers shall be shipped in boxes, crates, kegs or barrels. A list and description of the material shall appear on the outside of each closed container.

**Commentary:**

In most cases bolts, nuts and other components in a fastener assembly can be shipped loose in separate containers. However, ASTM F1852/F1852M twist-off-type tension-control bolt assemblies and galvanized ASTM A325, A325M and F1852/F1852M bolt assemblies must be assembled and shipped in the same container according to length and diameter.



## 6.7. Delivery of Materials

- 6.7.1. Fabricated Structural Steel shall be delivered in a sequence that will permit efficient and economical fabrication and erection, and that is consistent with requirements in the Contract Documents. If the Owner or Owner's Designated Representative for Construction wishes to prescribe or control the sequence of delivery of materials, that entity shall specify the required sequence in the Contract Documents. If the Owner's Designated Representative for Construction contracts separately for delivery and for erection, the Owner's Designated Representative for Construction shall coordinate planning between contractors.
- 6.7.2. Anchor Rods, washers, nuts and other anchorage or grillage materials that are to be built into concrete or masonry shall be shipped so that they will be available when needed. The Owner's Designated Representative for Construction shall allow the Fabricator sufficient time to fabricate and ship such materials before they are needed.
- 6.7.3. If any shortage is claimed relative to the quantities of materials that are shown in the shipping statements, the Owner's Designated Representative for Construction or the Erector shall promptly notify the Fabricator so that the claim can be investigated.

### **Commentary:**

The quantities of material that are shown in the shipping statement are customarily accepted as correct by the Owner's Designated Representative for Construction, the Fabricator and the Erector.

- 6.7.4. Unless otherwise specified in the Contract Documents, and subject to the approved Shop and Erection Drawings, the Fabricator shall limit the number of field splices to that consistent with minimum project cost.

### **Commentary:**

This Section recognizes that the size and weight of Structural Steel assemblies may be limited by shop capabilities, the permissible



40

weight and clearance dimensions of available transportation or job-site conditions.

- 6.7.5. If material arrives at its destination in damaged condition, the receiving entity shall promptly notify the Fabricator and carrier prior to unloading the material, or promptly upon discovery prior to erection.





## SECTION 7. ERECTION

### 7.1. Method of Erection

Fabricated Structural Steel shall be erected using methods and a sequence that will permit efficient and economical performance of erection, and that is consistent with the requirements in the Contract Documents. If the Owner or Owner's Designated Representative for Construction wishes to prescribe or control the method and/or sequence of erection, or specifies that certain members cannot be erected in their normal sequence, that entity shall specify the required method and sequence in the Contract Documents. If the Owner's Designated Representative for Construction contracts separately for fabrication services and for erection services, the Owner's Designated Representative for Construction shall coordinate planning between contractors.

#### **Commentary:**

Design modifications are sometimes requested by the Erector to allow or facilitate the erection of the Structural Steel frame. When this is the case, the Erector should notify the Fabricator prior to the preparation of Shop and Erection Drawings so that the Fabricator may refer the Erector's request to the Owner's Designated Representatives for Design and Construction for resolution.

### 7.2. Job-Site Conditions

The Owner's Designated Representative for Construction shall provide and maintain the following for the Fabricator and the Erector:

- (a) Adequate access roads into and through the job site for the safe delivery and movement of the material to be erected and of derricks, cranes, trucks and other necessary equipment under their own power;
- (b) A firm, properly graded, drained, convenient and adequate space at the job site for the operation of the Erector's equipment, free from overhead obstructions, such as power lines, telephone lines or similar conditions; and,
- (c) Adequate storage space, when the structure does not occupy the full available job site, to enable the Fabricator and the Erector to operate at maximum practical speed.



Otherwise, the Owner's Designated Representative for Construction shall inform the Fabricator and the Erector of the actual job-site conditions and/or special delivery requirements prior to bidding.

**7.3. Foundations, Piers and Abutments**

The accurate location, strength and suitability of, and access to, all foundations, piers and abutments shall be the responsibility of the Owner's Designated Representative for Construction.

**7.4. Building Lines and Bench Marks**

The Owner's Designated Representative for Construction shall be responsible for the accurate location of building lines and benchmarks at the job site and shall furnish the Erector with a plan that contains all such information. The Owner's Designated Representative for Construction shall establish offset building lines and reference elevations at each level for the Erector's use in the positioning of Adjustable Items (see Section 7.13.1.3), if any.

**7.5. Installation of Anchor Rods, Foundation Bolts and Other Embedded Items**

7.5.1. Anchor Rods, foundation bolts and other embedded items shall be set by the Owner's Designated Representative for Construction in accordance with an approved Embedment Drawing. The variation in location of these items from the dimensions shown in the Embedment Drawings shall be as follows:

- (a) The variation in dimension between the centers of any two Anchor Rods within an Anchor-Rod Group shall be equal to or less than 1/8 in. [3 mm].
- (b) The variation in dimension between the centers of adjacent Anchor-Rod Groups shall be equal to or less than 1/4 in. [6 mm].
- (c) The variation in elevation of the tops of Anchor Rods shall be equal to or less than plus or minus 1/2 in. [13 mm].
- (d) The accumulated variation in dimension between centers of Anchor-Rod Groups along the Established Column Line



through multiple Anchor-Rod Groups shall be equal to or less than 1/4 in. per 100 ft [2 mm per 10 000 mm], but not to exceed a total of 1 in. [25 mm].

- (e) The variation in dimension from the center of any Anchor-Rod Group to the Established Column Line through that group shall be equal to or less than 1/4 in. [6 mm].

The tolerances that are specified in (b), (c) and (d) shall apply to offset dimensions shown in the structural Design Drawings, measured parallel and perpendicular to the nearest Established Column Line, for individual columns that are shown in the structural Design Drawings as offset from Established Column Lines.

**Commentary:**

The tolerances established in this Section have been selected for compatibility with the holes sizes that are recommended for base plates in the AISC Manual of Steel Construction. If special conditions require more restrictive tolerances, the contractor responsible for setting the Anchor Rods should be so informed in the Contract Documents. When the Anchor Rods are set in sleeves, the adjustment provided may be used to satisfy the required Anchor-Rod setting tolerances.

- 7.5.2. Unless otherwise specified in the Contract Documents, Anchor Rods shall be set with their longitudinal axis perpendicular to the theoretical bearing surface.
- 7.5.3. Embedded items and Connection materials that are part of the work of other trades, but that will receive Structural Steel, shall be located and set by the Owner's Designated Representative for Construction in accordance with an approved Embedment Drawing. The variation in location of these items shall be limited to a magnitude that is consistent with the tolerances that are specified in Section 7.13 for the erection of the Structural Steel.
- 7.5.4. All work that is performed by the Owner's Designated Representative for Construction shall be completed so as not to delay or interfere with the work of the Fabricator and the Erector.



The Owner's Designated Representative for Construction shall conduct a survey of the as-built locations of Anchor Rods, foundation bolts and other embedded items, and shall verify that all items covered in Section 7.5 meet the corresponding tolerances. When corrective action is necessary, the Owner's Designated Representative for Construction shall obtain the guidance and approval of the Owner's Designated Representative for Design.

**Commentary:**

Few Fabricators or Erectors have the capability to provide this survey. Under standard practice, it is the responsibility of others.

**7.6. Installation of Bearing Devices**

All leveling plates, leveling nuts and washers and loose base and bearing plates that can be handled without a derrick or crane are set to line and grade by the Owner's Designated Representative for Construction. Loose base and bearing plates that require handling with a derrick or crane shall be set by the Erector to lines and grades established by the Owner's Designated Representative for Construction. The Fabricator shall clearly scribe loose base and bearing plates with lines or other suitable marks to facilitate proper alignment.

Promptly after the setting of Bearing Devices, the Owner's Designated Representative for Construction shall check them for line and grade. The variation in elevation relative to the established grade for all Bearing Devices shall be equal to or less than plus or minus 1/8 in. [3 mm]. The final location of Bearing Devices shall be the responsibility of the Owner's Designated Representative for Construction.

**Commentary:**

The 1/8 in. [3 mm] tolerance on elevation of Bearing Devices relative to established grades is provided to permit some variation in setting Bearing Devices, and to account for the accuracy that is attainable with standard surveying instruments. The use of leveling plates larger than 22 in. by 22 in. [550 mm by 550 mm] is discouraged and grouting is recommended with larger sizes. For the purposes of erection stability, the use of leveling nuts and washers is discouraged when base plates have less than four Anchor Rods.



## 7.7. Grouting

Grouting shall be the responsibility of the Owner's Designated Representative for Construction. Leveling plates and loose base and bearing plates shall be promptly grouted after they are set and checked for line and grade. Columns with attached base plates, beams with attached bearing plates and other similar members with attached Bearing Devices that are temporarily supported on leveling nuts and washers, shims or other similar leveling devices, shall be promptly grouted after the Structural Steel frame or portion thereof has been plumbed.

### **Commentary:**

In the majority of structures the vertical load from the column bases is transmitted to the foundations through structural grout. In general, there are three methods by which support is provided for column bases during erection:

- (a) Pre-grouted leveling plates or loose base plates;
- (b) Shims; and,
- (c) Leveling nuts and washers on the Anchor Rods beneath the column base.

Standard practice provides that loose base plates and leveling plates are to be grouted as they are set. Bearing Devices that are set on shims or leveling nuts are grouted after plumbing, which means that the weight of the erected Structural Steel frame is supported on the shims or washers, nuts and Anchor Rods. The Erector must take care to ensure that the load that is transmitted in this temporary condition does not exceed the strength of the shims or washers, nuts and Anchor Rods. These considerations are presented in greater detail in AISC Design Guides No. 1 and 10.

## 7.8. Field Connection Material

- 7.8.1. The Fabricator shall provide field Connection details that are consistent with the requirements in the Contract Documents and that



46

will, in the Fabricator's opinion, result in economical fabrication and erection.

- 7.8.2. When the Fabricator is responsible for erecting the Structural Steel, the Fabricator shall furnish all materials that are required for both temporary and permanent Connection of the component parts of the Structural Steel frame.
- 7.8.3. When the erection of the Structural Steel is not performed by the Fabricator, the Fabricator shall furnish the following field Connection material:
- (a) Bolts, nuts and washers of the required grade, type and size and in sufficient quantity for all Structural Steel-to-Structural Steel field Connections that are to be permanently bolted, including an extra 2 percent of each bolt size (diameter and length);
  - (b) Shims that are shown as necessary for make-up of permanent Structural Steel-to-Structural Steel Connections; and,
  - (c) Backing bars and run-off tabs that are required for field welding.
- 7.8.4. The Erector shall furnish all welding electrodes, fit-up bolts and drift pins used for the erection of the Structural Steel.

**Commentary:**

See the commentary for Section 2.2.

**7.9. Loose Material**

Unless otherwise specified in the Contract Documents, loose Structural Steel items that are not connected to the Structural Steel frame shall be set by the Owner's Designated Representative for Construction without assistance from the Erector.

**7.10. Temporary Support of Structural Steel Frames**

- 7.10.1. The Owner's Designated Representative for Design shall identify the following in the Contract Documents:



- (a) The lateral-load-resisting system and connecting diaphragm elements that provide for lateral strength and stability in the completed structure; and,
- (b) Any special erection conditions or other considerations that are required by the design concept, such as the use of shores, jacks or loads that must be adjusted as erection progresses to set or maintain camber, position within specified tolerances or pre-stress.

**Commentary:**

See Commentary Section 7.10.3.

- 7.10.2. The Owner's Designated Representative for Construction shall indicate to the Erector prior to bidding, the installation schedule for non-Structural Steel elements of the lateral-load-resisting system and connecting diaphragm elements identified by the Owner's Designated Representative for Design in the Contract Documents.

**Commentary:**

See Commentary Section 7.10.3.

- 7.10.3. Based upon the information provided in accordance with Sections 7.10.1 and 7.10.2, the Erector shall determine, furnish and install all temporary supports, such as temporary guys, beams, falsework, cribbing or other elements required for the erection operation. These temporary supports shall be sufficient to secure the bare Structural Steel framing or any portion thereof against loads that are likely to be encountered during erection, including those due to wind and those that result from erection operations.

The Erector need not consider loads during erection that result from the performance of work by, or the acts of, others, except as specifically identified by the Owner's Designated Representatives for Design and Construction, nor those that are unpredictable, such as loads due to hurricane, tornado, earthquake, explosion or collision.

Temporary supports that are required during or after the erection of the Structural Steel frame for the support of loads



caused by non-Structural Steel elements, including cladding, interior partitions and other such elements that will induce or transmit loads to the Structural Steel frame during or after erection, shall be the responsibility of others.

**Commentary:**

Many Structural Steel frames have lateral-load-resisting systems that are activated during the erection process. Such lateral-load-resisting systems may consist of welded moment frames, braced frames or, in some instances, columns that cantilever from fixed-base foundations. Such frames are normally braced with temporary guys that, together with the steel deck floor and roof diaphragms, or other diaphragm bracing that may be included as part of the design, provide stability during the erection process. The guy cables are also commonly used to plumb the Structural Steel frame. The Erector normally furnishes and installs the required temporary supports and bracing to secure the bare Structural Steel frame, or portion thereof, during the erection process.

If the Owner's Designated Representative for Construction determines that steel decking is not installed by the Erector, temporary diaphragm bracing may be required if a horizontal diaphragm is not available to distribute loads to the vertical and lateral load resisting system. If the steel deck will not be available as a diaphragm during Structural Steel erection, the Owner's Designated Representative for Construction must communicate this condition to the Erector prior to bidding. If such diaphragm bracing is required, it must be furnished and installed by the Erector.

Sometimes structural systems that are employed by the Owner's Designated Representative for Design rely upon other elements besides the Structural Steel frame for lateral-load resistance. For instance, concrete or masonry shear walls or precast spandrels may be used to provide resistance to vertical and lateral loads in the completed structure. Because these situations may not be obvious to the contractor or the Erector, it is required in this Code that the Owner's Designated Representative for Design identify such situations in the Contract Documents. Similarly, if a structure is designed so that special erection techniques are required, such as jacking to impose certain loads or position during erection, it is





required in this Code that such requirements be specifically identified in the Contract Documents.

In some instances, the Owner's Designated Representative for Design may elect to show erection bracing in the Design Drawings. When this is the case, the Owner's Designated Representative for Design should then confirm that the bracing requirements were understood by review and approval of the Erection Drawings during the submittal process.

Sometimes during construction of a building, collateral building elements, such as exterior cladding, may be required to be installed on the bare Structural Steel frame prior to completion of the lateral-load-resisting system. These elements may increase the potential for lateral loads on the temporary supports. Such temporary supports may also be required to be left in place after the Structural Steel frame has been erected. Special provisions should be made by the Owner's Designated Representative for Construction for these conditions.

- 7.10.4. All temporary supports that are required for the erection operation and furnished and installed by the Erector shall remain the property of the Erector and shall not be modified, moved or removed without the consent of the Erector. Temporary supports provided by the Erector shall remain in place until the portion of the Structural Steel frame that they brace is complete and the lateral-load-resisting system and connecting diaphragm elements identified by the Owner's Designated Representative for Design in accordance with Section 7.10.1 are installed. Temporary supports that are required to be left in place after the completion of Structural Steel erection shall be removed when no longer needed by the Owner's Designated Representative for Construction and returned to the Erector in good condition.

## **7.11. Safety Protection**

- 7.11.1. The Erector shall provide floor coverings, handrails, walkways and other safety protection for the Erector's personnel as required by law and the applicable safety regulations. Unless otherwise specified in the Contract Documents, the Erector is permitted to remove



50

such safety protection from areas where the erection operations are completed.

7.11.2 When safety protection provided by the Erector is left in an area for the use of other trades after the Structural Steel erection activity is completed, the Owner's Designated Representative for Construction shall:

- (a) Accept responsibility for and maintain this protection;
- (b) Indemnify the Fabricator and the Erector from damages that may be incurred from the use of this protection by other trades;
- (c) Ensure that this protection is adequate for use by other affected trades;
- (d) Ensure that this protection complies with applicable safety regulations when being used by other trades; and,
- (e) Remove this protection when it is no longer required and return it to the Erector in the same condition as it was received.

7.11.3. Safety protection for other trades that are not under the direct employment of the Erector shall be the responsibility of the Owner's Designated Representative for Construction.

7.11.4. When permanent steel decking is used for protective flooring and is installed by the Owner's Designated Representative for Construction, all such work shall be scheduled and performed in a timely manner so as not to interfere with or delay the work of the Fabricator or the Erector. The sequence of installation that is used shall meet all safety regulations.

7.11.5. Unless the interaction and safety of activities of others, such as construction by others or the storage of materials that belong to others, are coordinated with the work of the Erector by the Owner's Designated Representative for Construction, such activities shall not be permitted until the erection of the Structural Steel frame or portion thereof is completed by the Erector and accepted by the Owner's Designated Representative for Construction.



### 7.12. Structural Steel Frame Tolerances

The accumulation of the mill tolerances and fabrication tolerances shall not cause the erection tolerances to be exceeded.

#### **Commentary:**

In previous editions of this Code, it was stated that "...variations are deemed to be within the limits of good practice when they do not exceed the cumulative effect of rolling tolerances, fabricating tolerances and erection tolerances." It is recognized in the current provision in this Section that accumulations of mill tolerances and fabrication tolerances generally occur between the locations at which erection tolerances are applied, and not at the same locations.

### 7.13. Erection Tolerances

Erection tolerances shall be defined relative to member working points and working lines, which shall be defined as follows:

- (a) For members other than horizontal members, the member work point shall be the actual center of the member at each end of the shipping piece.
- (b) For horizontal members, the working point shall be the actual centerline of the top flange or top surface at each end.
- (c) The member working line shall be the straight line that connects the member working points.

The substitution of other working points is permitted for ease of reference, provided they are based upon the above definitions.

The tolerances on Structural Steel erection shall be in accordance with the requirements in Sections 7.13.1 through 7.13.3.

#### **Commentary:**

The erection tolerances defined in this Section have been developed through long-standing usage as practical criteria for the erection of Structural Steel. Erection tolerances were first defined in the 1924 edition of this Code in Section 7(f), "Plumbing Up." With the changes that took place in the types and use of materials in building construction after World War II, and the increasing demand by



Architects and Owners for more specific tolerances, AISC adopted new standards for erection tolerances in Section 7(h) of the March 15, 1959 edition of this Code. Experience has proven that those tolerances can be economically obtained.

Differential column shortening may be a consideration in design and construction. In some cases, it may occur due to variability in the accumulation of dead load among different columns (see Figure C-7.1). In other cases, it may be characteristic of the structural system that is employed in the design. Consideration of the effects of differential column shortening may be very important, such as when the slab thickness is reduced, when electrical and other similar fittings mounted on the Structural Steel are intended to be flush with the finished floor and when there is little clearance between bottoms of beams and the tops of door frames or ductwork.

Expansion and contraction in a Structural Steel frame may also be a consideration in the design and construction. Steel will expand or contract approximately 1/8 in. per 100 ft for each change of 15°F [2 mm per 10 000 mm for each change of 15°C] in temperature. This change in length can be assumed to act about the center of rigidity. When anchored to their foundations, end columns will be plumb only when the steel is at normal temperature (see Figure C-7.2). It is therefore necessary to correct field measurements of offsets to the structure from established baselines for the expansion or contraction of the exposed Structural Steel frame. For example, a 200-ft-long [60 000-m-long] building that is plumbed up at 100°F [38°C] should have working points at the tops of the end columns positioned 1/2 in. [14 mm] further apart than the working points at the corresponding bases in order for the columns to be plumb at 70°F [21°C]. Differential temperature effects on column length should also be taken into account in plumbing surveys when tall Structural Steel frames are subjected to sun exposure on one side.

The alignment of lintels, spandrels, wall supports and similar members that are used to connect other building construction units to the Structural Steel frame should have an adjustment of sufficient magnitude to allow for the accumulation of mill tolerances and fabrication tolerances, as well as the erection tolerances. See Figure C-7.3.



7.13.1. The tolerances on position and alignment of member working points and working lines shall be as described in Sections 7.13.1.1 through 7.13.1.3.

7.13.1.1. For an individual column shipping piece, the angular variation of the working line from a plumb line shall be equal to or less than

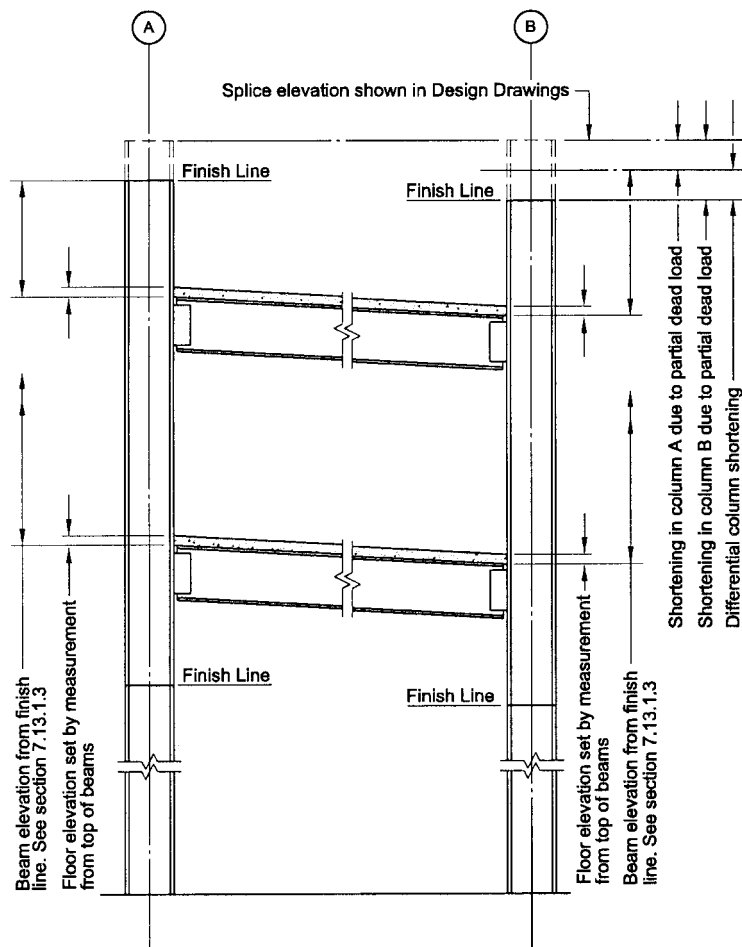


Figure C-7.1. Effects of differential column shortening.



When plumbing columns, apply a temperature adjustment at a rate of 1/8 in. per 100 ft. for each change of 15°F [2 mm per 10 000 mm for each change of 15°C] between the temperature at the time of erection and the working temperature.

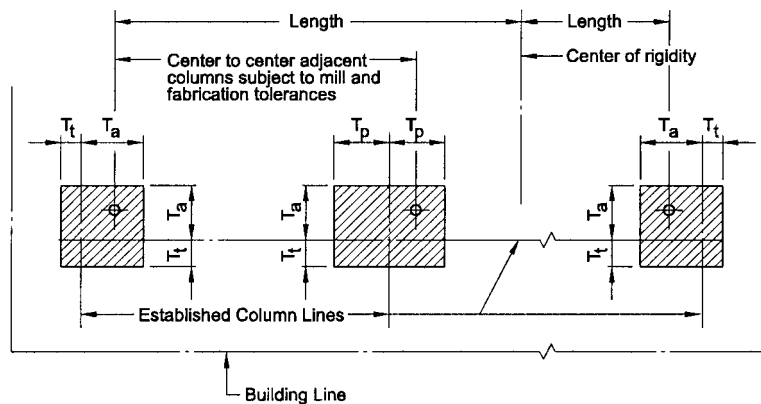


Figure C-7.2. Tolerances in plan location of column.

1/500 of the distance between working points, subject to the following additional limitations:

- (a) For an individual column shipping piece that is adjacent to an elevator shaft, the displacement of member working points shall be equal to or less than 1 in. [25 mm] from the Established Column Line in the first 20 stories. Above this level, an increase in the displacement of 1/32 in. [1 mm] is permitted for each additional story up to a maximum displacement of 2 in. [50 mm] from the Established Column Line.
- (b) For an exterior individual column shipping piece, the displacement of member working points from the Established Column Line in the first 20 stories shall be equal to or less than 1 in. [25 mm] toward and 2 in. [50 mm] away from the building line. Above this level, an increase in the displacement of 1/16 in. [2 mm] is permitted for each additional story up to a maximum



displacement of 2 in. [50 mm] toward and 3 in. [75 mm] away from the building line.

**Commentary:**

The limitations that are described in this Section and illustrated in Figures C-7.4 and C-7.5 make it possible to maintain built-in-place or prefabricated facades in a true vertical plane up to the 20th story, if Connections that provide for 3 in. [75 mm] of adjustment are used. Above the 20th story, the facade may be maintained within 1/16 in. [2 mm] per story with a maximum total deviation of 1 in. [25 mm] from a true vertical plane, if Connections that provide for 3 in. [75 mm] of adjustment are used. Connections that permit adjustments of plus 2 in. [50 mm] to minus 3 in. [75 mm] (5 in. [125 mm] total) will be necessary in cases where it is desired to construct the facade to a true vertical plane above the 20th story.

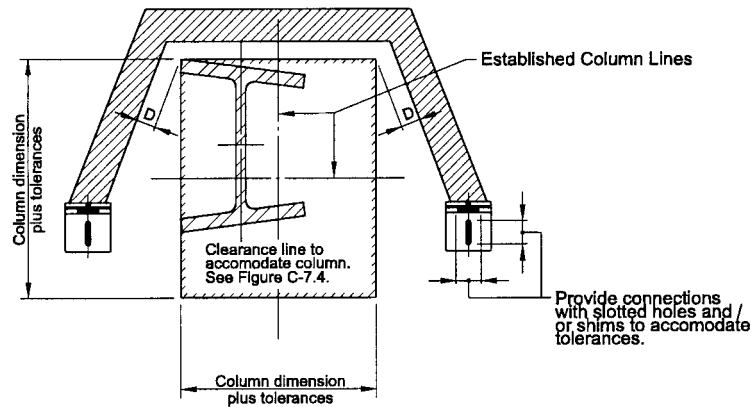
- (c) For an exterior individual column shipping piece, the member working points at any splice level for multi-Tier buildings and at the tops of columns for single-Tier buildings shall fall within a horizontal envelope, parallel to the building line, that is equal to or less than 1 1/2 in. [38 mm] wide for buildings up to 300 ft [90 000 mm] in length. An increase in the width of this horizontal envelope of 1/2 in. [13 mm] is permitted for each additional 100 ft [30 000 m] in length up to a maximum width of 3 in. [75 mm].

**Commentary:**

This Section limits the position of exterior column working points at any given splice elevation to a narrow horizontal envelope parallel to the building line (see Figure C-7.6). This envelope is limited to a width of 1 1/2 in. [38 mm], normal to the building line, in up to 300 ft [90 000 mm] of building length. The horizontal location of this envelope is not necessarily directly above or below the corresponding envelope at the adjacent splice elevations, but should be within the limitation of the 1 in 500 plumbness tolerance specified for the controlling columns (see Figure C-7.5).



56



If fascia joints are set from nearest column finish line, allow  $\pm 5/8$  in. [16mm] for vertical adjustment. The entity responsible for the fascia details must allow for progressive shortening of steel columns.

D= Tolerances required by manufacturer of wall units plus survey tolerances.

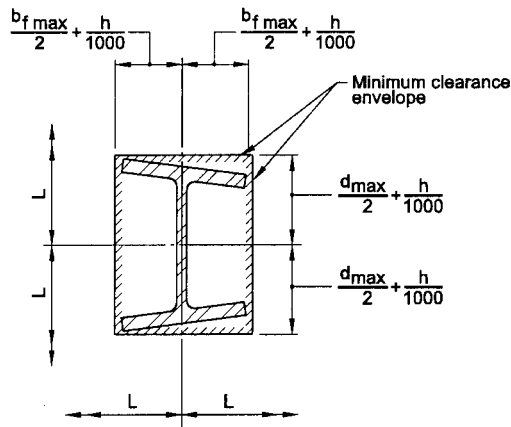
Figure C-7.3. Clearance required to accommodate fascia.

- (d) For an exterior column shipping piece, the displacement of member working points from the Established Column Line, parallel to the building line, shall be equal to or less than 2 in. [50 mm] in the first 20 stories. Above this level, an increase in the displacement of 1/16 in. [2 mm] is permitted for each additional story up to a maximum displacement of 3 in. [75 mm] parallel to the building line.

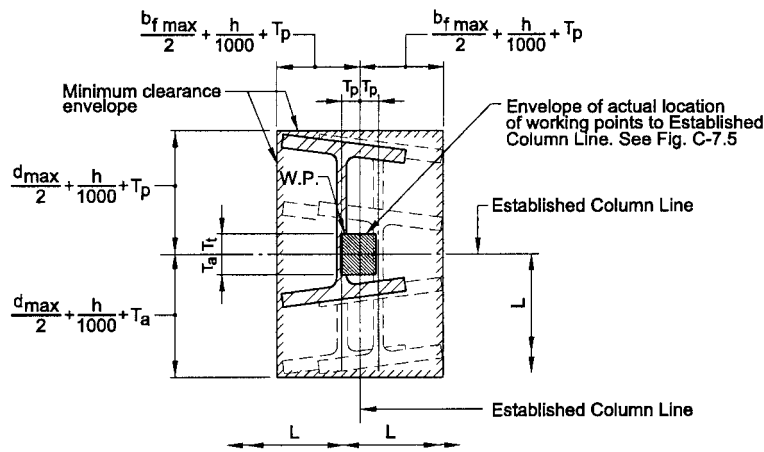
7.13.1.2. For members other than column shipping pieces, the following limitations shall apply:

- (a) For a member that consists of an individual, straight shipping piece without field splices, other than a cantilevered member,





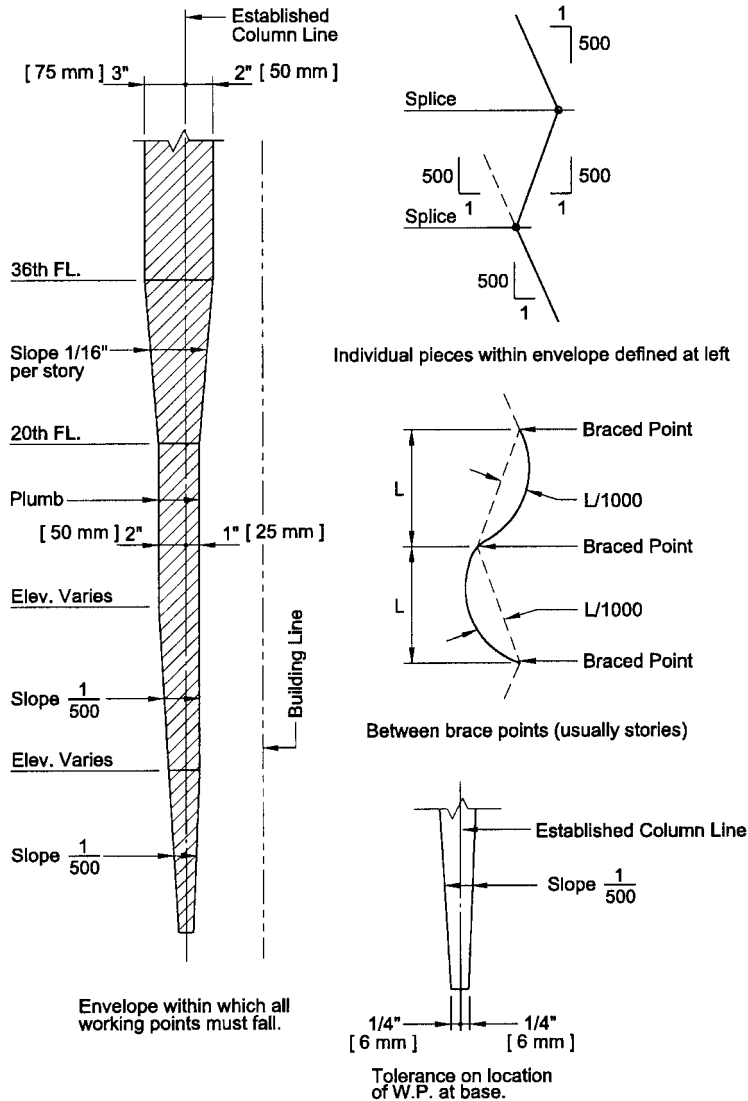
For enclosures or attachments that may follow column alignment.



For enclosures or attachments that must be held to precise plan location.

- L = Actual center to center of columns = plan dimensions ± column cross section tolerance of columns ± beam length tolerance.
- T<sub>a</sub> = Plumbness tolerance away from building line (varies, see Fig. C-7.5)
- T<sub>†</sub> = Plumbness tolerance toward building line (varies, see Fig. C-7.5)
- T<sub>p</sub> = Plumbness tolerance parallel to building line (=T<sub>a</sub>)

Figure C-7.4. Clearance required to accommodate accumulated column tolerances.



Note: The plumb line through the base working point for an individual column is not necessarily the precise plan location because Sect. 7.13.1.1 deals only with plumbness tolerances and does not include inaccuracies in location of the Established Column Line, foundations and anchor rods beyond the Erector's control

Figure C-7.5. Exterior column plumbness tolerances normal to building line.

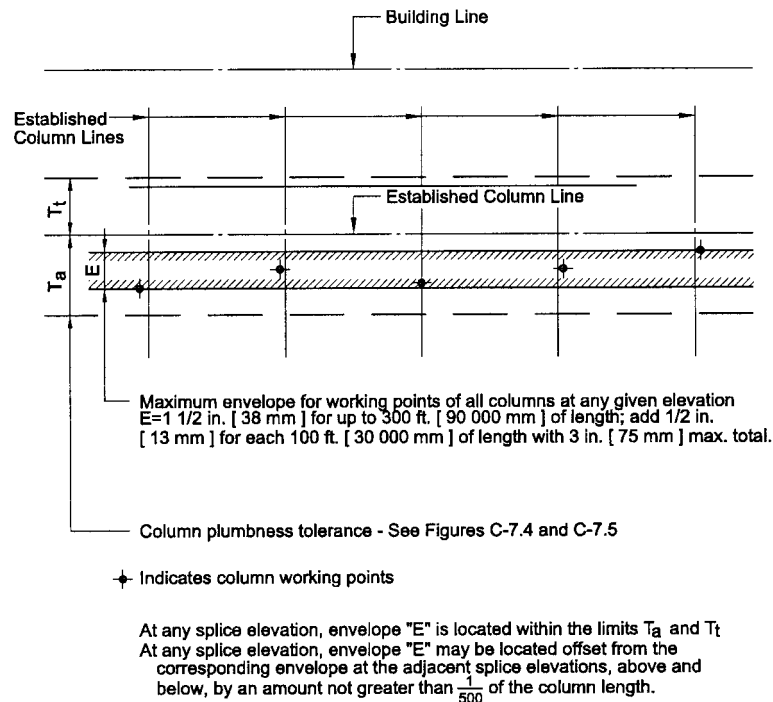


Figure C-7.6. Tolerances in plan at any splice elevation of exterior columns.

the variation in alignment shall be acceptable if it is caused solely by variations in column alignment and/or primary supporting member alignment that are within the permissible variations for the fabrication and erection of such members.

- (b) For a member that consists of an individual, straight shipping piece that connects to a column, the variation in the distance from the member working point to the upper finished splice line of the column shall be equal to or less than plus  $3/16$  in. [5 mm] and minus  $5/16$  in. [8 mm].
- (c) For a member that consists of an individual shipping piece that does not connect to a column, the variation in elevation shall be acceptable if it is caused solely by the variations in the elevations of the supporting members within the permissible variations for the fabrication and erection of those members.



- (d) For a member that consists of an individual, straight shipping piece and that is a segment of a field assembled unit containing field splices between points of support, the plumbness, elevation and alignment shall be acceptable if the angular variation of the working line from the plan alignment is equal to or less than  $1/500$  of the distance between working points.
- (e) For a cantilevered member that consists of an individual, straight shipping piece, the plumbness, elevation and alignment shall be acceptable if the angular variation of the working line from a straight line that is extended in the plan direction from the working point at its supported end is equal to or less than  $1/500$  of the distance from the working point at the free end.
- (f) For a member of irregular shape, the plumbness, elevation and alignment shall be acceptable if the fabricated member is within its tolerances and the members that support it are within the tolerances specified in this Code.

**Commentary:**

The angular misalignment of the working line of all fabricated shipping pieces relative to the line between support points of the member as a whole in erected position must not exceed 1 in 500. Note that the tolerance is not stated in terms of a linear displacement at any point and is not to be taken as the overall length between supports divided by 500. Typical examples are shown in Figure C-7.7. Numerous conditions within tolerance for these and other cases are possible. This condition applies to both plan and elevation tolerances.

7.13.1.3. For members that are identified as Adjustable Items by the Owner's Designated Representative for Design in the Contract Documents, the Fabricator shall provide adjustable Connections for these members to the supporting Structural Steel frame. Otherwise, the Fabricator is permitted to provide non-adjustable Connections. When Adjustable Items are specified, the Owner's Designated Representative for Design shall indicate the total adjustability that is required for the proper alignment of these supports for other trades. The variation in the position and alignment of Adjustable Items shall be as follows:

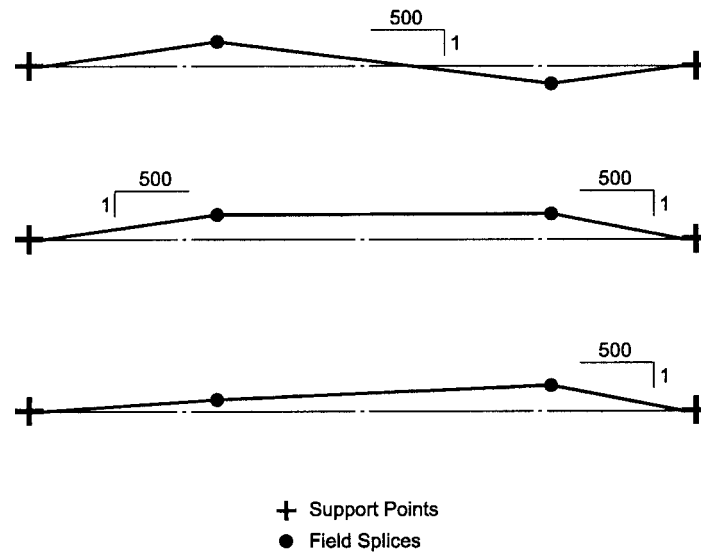


Figure C-7.7. Alignment tolerances for members with field splices.

- (a) The variation in the vertical distance from the upper finished splice line of the nearest column to the support location specified in the structural Design Drawings shall be equal to or less than plus or minus 3/8 in. [10 mm].
- (b) The variation in the horizontal distance from the established finish line at the particular floor shall be equal to or less than plus or minus 3/8 in. [10 mm].
- (c) The variation in vertical and horizontal alignment at the abutting ends of Adjustable Items shall be equal to or less than plus or minus 3/16 in. [5 mm].

**Commentary:**

When the alignment of lintels, wall supports, curb angles, mullions and similar supporting members for the use of other trades is required to be closer than that permitted by the foregoing tolerances for Structural Steel, the Owner's Designated Representative for



Design must identify such items in the Contract Documents as Adjustable Items.

- 7.13.2. In the design of steel structures, the Owner's Designated Representative for Design shall provide for the necessary clearances and adjustments for material furnished by other trades to accommodate the mill tolerances, fabrication tolerances and erection tolerances in this Code for the Structural Steel frame.

**Commentary:**

In spite of all efforts to minimize inaccuracies, deviations will still exist; therefore, in addition, the designs of prefabricated wall panels, partition panels, fenestrations, floor-to-ceiling door frames and similar elements must provide for clearance and details for adjustment as described in Section 7.13.2. Designs must provide for adjustment in the vertical dimension of prefabricated facade panels that are supported by the Structural Steel frame because the accumulation of shortening of loaded steel columns will result in the unstressed facade supported at each floor level being higher than the Structural Steel framing to which it must be attached. Observations in the field have shown that where a heavy facade is erected to a greater height on one side of a multistory building than on the other, the Structural Steel framing will be pulled out of alignment. Facades should be erected at a relatively uniform rate around the perimeter of the structure.

- 7.13.3. Prior to placing or applying any other materials, the Owner's Designated Representative for Construction shall determine that the location of the Structural Steel is acceptable for plumbness, elevation and alignment. The Erector shall be given either timely notice of acceptance by the Owner's Designated Representative for Construction, or a listing of specific items that are to be corrected in order to obtain acceptance. Such notice shall be rendered promptly upon completion of any part of the work and prior to the start of work by other trades that may be supported, attached or applied to the Structural Steel frame.

**7.14. Correction of Errors**

The correction of minor misfits by moderate amounts of reaming, grinding, welding or cutting, and the drawing of elements into line with drift pins, shall be considered to be normal erection operations. Errors that cannot be corrected using the foregoing means, or that require major changes in member or Connection configuration, shall be promptly reported to the Owner's Designated Representatives for Design and Construction and the Fabricator by the Erector, to enable the responsible entity to either correct the error or approve the most efficient and economical method of correction to be used by others.

**Commentary:**

As used in this Section, the term "moderate" refers to the amount of reaming, grinding, welding or cutting that must be done on the project as a whole, not the amount that is required at an individual location. It is not intended to address limitations on the amount of material that is removed by reaming at an individual bolt hole, for example, which is limited by the bolt-hole size and tolerance requirements in the AISC and RCSC Specifications.

**7.15. Cuts, Alterations and Holes for Other Trades**

Neither the Fabricator nor the Erector shall cut, drill or otherwise alter their work, nor the work of other trades, to accommodate other trades, unless such work is clearly specified in the Contract Documents. When such work is so specified, the Owner's Designated Representatives for Design and Construction shall furnish complete information as to materials, size, location and number of alterations in a timely manner so as not to delay the preparation of Shop and Erection Drawings.

**7.16. Handling and Storage**

The Erector shall take reasonable care in the proper handling and storage of the Structural Steel during erection operations to avoid the accumulation of excess dirt and foreign matter. The Erector shall not be responsible for the removal from the Structural Steel of dust, dirt or other foreign matter that may accumulate during erection.



tion as the result of job-site conditions or exposure to the elements. The Erector shall handle and store all bolts, nuts, washers and related fastening products in accordance with the requirements of the RCSC Specification.

**Commentary:**

During storage, loading, transport, unloading and erection, blemish marks caused by slings, chains, blocking, tie-downs, etc., occur in varying degrees. Abrasions caused by handling or cartage after painting are to be expected. It must be recognized that any shop-applied coating, no matter how carefully protected, will require touching-up in the field. Touching-up of these blemished areas is the responsibility of the contractor performing the field touch-up or field painting.

The Erector is responsible for the proper storage and handling of fabricated Structural Steel at the job site during erection. Shop-painted Structural Steel that is stored in the field pending erection should be kept free of the ground and positioned so as to minimize the potential for water retention. The Owner or Owner's Designated Representative for Construction is responsible for providing suitable job-site conditions and proper access so that the Fabricator/Erector may perform its work.

Job-site conditions are frequently muddy, sandy, dusty or a combination thereof during the erection period. Under such conditions it may be impossible to store and handle the Structural Steel in such a way as to completely avoid any accumulation of mud, dirt or sand on the surface of the Structural Steel, even though the Fabricator and the Erector manages to proceed with their work.

Repairs of damage to painted surfaces and/or removal of foreign materials due to adverse job-site conditions are outside the scope of responsibility of the Fabricator and the Erector when reasonable attempts at proper handling and storage have been made.

**7.17. Field Painting**

Neither the Fabricator nor the Erector is responsible to paint field bolt heads and nuts or field welds, nor to touch up abrasions of the shop coat, nor to perform any other field painting.





**7.18. Final Cleaning Up**

Upon the completion of erection and before final acceptance, the Erector shall remove all of the Erector's falsework, rubbish and temporary buildings.



## SECTION 8. QUALITY ASSURANCE

### 8.1. General

- 8.1.1. The Fabricator shall maintain a quality assurance program to ensure that the work is performed in accordance with the requirements in this Code, the AISC Specification and the Contract Documents. The Fabricator shall have the option to use the AISC Quality Certification Program to establish and administer the quality assurance program.

**Commentary:**

The AISC Quality Certification Program confirms to the construction industry that a certified Structural Steel fabrication shop has the capability by reason of commitment, personnel, organization, experience, procedures, knowledge and equipment to produce fabricated Structural Steel of the required quality for a given category of work. The AISC Quality Certification Program is not intended to involve inspection and/or judgment of product quality on individual projects. Neither is it intended to guarantee the quality of specific fabricated Structural Steel products.

- 8.1.2. The Erector shall maintain a quality assurance program to ensure that the work is performed in accordance with the requirements in this Code, the AISC Specification and the Contract Documents. The Erector shall be capable of performing the erection of the Structural Steel, and shall provide the equipment, personnel and management for the scope, magnitude and required quality of each project. The Erector shall have the option to use the AISC Erector Certification Program to establish and administer the quality assurance program.

**Commentary:**

The AISC Erector Certification Program confirms to the construction industry that a certified Structural Steel Erector has the capability by reason of commitment, personnel, organization, experience, procedures, knowledge and equipment to erect fabricated Structural Steel to the required quality for a given category of work.



The AISC Erector Certification Program is not intended to involve inspection and/or judgment of product quality on individual projects. Neither is it intended to guarantee the quality of specific erected Structural Steel products.

- 8.1.3. When the Owner requires more extensive quality assurance or independent inspection by qualified personnel, or requires that the Fabricator be certified under the AISC Quality Certification Program and/or requires that the Erector be certified under the AISC Erector Certification Program, this shall be clearly stated in the Contract Documents, including a definition of the scope of such inspection.

**8.2. Inspection of Mill Material**

Certified mill test reports shall constitute sufficient evidence that the mill product satisfies material order requirements. The Fabricator shall make a visual inspection of material that is received from the mill, but need not perform any material tests unless the Owner's Designated Representative for Design specifies in the Contract Documents that additional testing is to be performed at the Owner's expense.

**8.3. Non-Destructive Testing**

When non-destructive testing is required, the process, extent, technique and standards of acceptance shall be clearly specified in the Contract Documents.

**8.4. Surface Preparation and Shop Painting Inspection**

Inspection of surface preparation and shop painting shall be planned for the acceptance of each operation as the Fabricator completes it. Inspection of the paint system, including material and thickness, shall be made promptly upon completion of the paint application. When wet-film thickness is to be inspected, it shall be measured during the application.

**8.5. Independent Inspection**

When inspection by personnel other than those of the Fabricator and/or Erector is specified in the Contract Documents, the require-



ments in Sections 8.5.1 through 8.5.6 shall be met.

- 8.5.1. The Fabricator and the Erector shall provide the Inspector with access to all places where the work is being performed. A minimum of 24 hours notification shall be given prior to the commencement of work.
- 8.5.2. Inspection of shop work by the Inspector shall be performed in the Fabricator's shop to the fullest extent possible. Such inspections shall be timely, in-sequence and performed in such a manner as will not disrupt fabrication operations and will permit the repair of non-conforming work prior to any required painting while the material is still in-process in the fabrication shop.
- 8.5.3. Inspection of field work shall be promptly completed without delaying the progress or correction of the work.
- 8.5.4. Rejection of material or workmanship that is not in conformance with the Contract Documents shall be permitted at any time during the progress of the work. However, this provision shall not relieve the Owner or the Inspector of the obligation for timely, in-sequence inspections.
- 8.5.5. The Fabricator and the Erector shall be informed of deficiencies that are noted by the Inspector promptly after the inspection. Copies of all reports prepared by the Inspector shall be promptly given to the Fabricator and the Erector. The necessary corrective work shall be performed in a timely manner.
- 8.5.6. The Inspector shall not suggest, direct, or approve the Fabricator or Erector to deviate from the Contract Documents or the approved Shop and Erection Drawings, or approve such deviation, without the written approval of the Owner's Designated Representatives for Design and Construction.



## SECTION 9. CONTRACTS

### 9.1. Types of Contracts

- 9.1.1. For contracts that stipulate a lump sum price, the work that is required to be performed by the Fabricator and the Erector shall be completely defined in the Contract Documents.
- 9.1.2. For contracts that stipulate a price per pound, the scope of work that is required to be performed by the Fabricator and the Erector, the type of materials, the character of fabrication and the conditions of erection shall be based upon the Contract Documents, which shall be representative of the work to be performed.
- 9.1.3. For contracts that stipulate a price per item, the work that is required to be performed by the Fabricator and the Erector shall be based upon the quantity and the character of the items that are described in the Contract Documents.
- 9.1.4. For contracts that stipulate unit prices for various categories of Structural Steel, the scope of work that is required to be performed by the Fabricator and the Erector shall be based upon the quantity, character and complexity of the items in each category as described in the Contract Documents, and shall also be representative of the work to be performed in each category.

### 9.2. Calculation of Weights

Unless otherwise specified in the contract, for contracts stipulating a price per pound for fabricated Structural Steel that is delivered and/or erected, the quantities of materials for payment shall be determined by the calculation of the gross weight of materials as shown in the Shop Drawings.

#### **Commentary:**

The standard procedure for calculation of weights that is described in this Code meets the need for a universally acceptable system for defining “pay weights” in contracts based upon the weight of delivered and/or erected materials. These procedures permits the Owner



to easily and accurately evaluate price-per-pound proposals from potential suppliers and enables all parties to a contract to have a clear and common understanding of the basis for payment.

The procedure in this Code affords a simple, readily understood method of calculation that will produce pay weights that are consistent throughout the industry and that may be easily verified by the Owner. While this procedure does not produce actual weights, it can be used by purchasers and suppliers to define a widely accepted basis for bidding and contracting for Structural Steel. However, any other system can be used as the basis for a contractual agreement. When other systems are used, both the supplier and the purchaser should clearly understand how the alternative procedure is handled.

- 9.2.1. The unit weight of steel shall be taken as 490 lb/ft<sup>3</sup> [7 850 kg/m<sup>3</sup>]. The unit weight of other materials shall be in accordance with the manufacturer's published data for the specific product.
- 9.2.2. The weights of Standard Structural Shapes, plates and bars shall be calculated on the basis of Shop Drawings that show the actual quantities and dimensions of material to be fabricated, as follows:
  - (a) The weights of all Standard Structural Shapes shall be calculated using the nominal weight per ft [mass per m] and the detailed overall length.
  - (b) The weights of plates and bars shall be calculated using the detailed overall rectangular dimensions.
  - (c) When parts can be economically cut in multiples from material of larger dimensions, the weight shall be calculated on the basis of the theoretical rectangular dimensions of the material from which the parts are cut.
  - (d) When parts are cut from Standard Structural Shapes, leaving a non-standard section that is not useable on the same contract, the weight shall be calculated using the nominal weight per ft [mass per m] and the detailed overall length of the Standard Structural Shapes from which the parts are cut.
  - (e) Deductions shall not be made for material that is removed for cuts, copes, clips, blocks, drilling, punching, boring, slot milling, planing or weld joint preparation.



- 9.2.3. The items for which weights are shown in tables in the AISC Manual of Steel Construction shall be calculated on the basis of the tabulated weights shown therein.
- 9.2.4. The weights of items that are not shown in tables in the AISC Manual of Steel Construction shall be taken from the manufacturer's catalog and the manufacturer's shipping weight shall be used.

**Commentary:**

Many items that are weighed for payment purposes are not tabulated with weights in the AISC Manual of Steel Construction. These include, but are not limited to, Anchor Rods, clevises, turnbuckles, sleeve nuts, recessed-pin nuts, cotter pins and similar devices.

- 9.2.5. The weights of shop or field weld metal and protective coatings shall not be included in the calculated weight for the purposes of payment.

**9.3. Revisions to the Contract Documents**

Revisions to the Contract Documents shall be confirmed by change order or extra work order. Unless otherwise noted, the issuance of a revision to the Contract Documents shall constitute authorization by the Owner that the revision is Released for Construction. The contract price and schedule shall be adjusted in accordance with Sections 9.4 and 9.5.

**9.4. Contract Price Adjustment**

- 9.4.1. When the scope of work and responsibilities of the Fabricator and the Erector are changed from those previously established in the Contract Documents, an appropriate modification of the contract price shall be made. In computing the contract price adjustment, the Fabricator and the Erector shall consider the quantity of work that is added or deleted, the modifications in the character of the work and the timeliness of the change with respect to the status of material ordering, detailing, fabrication and erection operations.

**Commentary:**

The fabrication and erection of Structural Steel is a dynamic process. Typically, material is being acquired at the same time that the Shop and Erection Drawings are being prepared. Additionally, the fabrication shop will normally fabricate pieces in the order that the Structural Steel is being shipped and erected.

Items that are revised or placed on hold generally upset these relationships and can be very disruptive to the detailing, fabricating and erecting processes. The provisions in Sections 3.5, 4.4.2 and 9.3 are intended to minimize these disruptions so as to allow work to continue. Accordingly, it is required in this Code that the reviewer of requests for contract price adjustments recognize this and allow compensation to the Fabricator and the Erector for these inefficiencies and for the materials that are purchased and the detailing, fabrication and erection that has been performed, when affected by the change.

- 9.4.2. Requests for contract price adjustments shall be presented by the Fabricator and/or the Erector in a timely manner and shall be accompanied by a description of the change that is sufficient to permit evaluation and timely approval by the Owner.
- 9.4.3. Price-per-pound and price-per-item contracts shall provide for additions or deletions to the quantity of work that are made prior to the time the work is Released for Construction. When changes are made to the character of the work at any time, or when additions and/or deletions are made to the quantity of the work after it is released for detailing, fabrication or erection, the contract price shall be equitably adjusted.

**9.5. Scheduling**

- 9.5.1. The contract schedule shall state when the Design Drawings will be Released for Construction, if the Design Drawings are not available at the time of bidding, and when the job site, foundations, piers and abutments will be ready, free from obstructions and accessible to the Erector, so that erection can start at the designated time and continue without interference or delay caused by the Owner's Designated Representative for Construction or other trades.





- 9.5.2. The Fabricator and the Erector shall advise the Owner's Designated Representatives for Design and Construction, in a timely manner, of the effect any revision has on the contract schedule.
- 9.5.3. If the fabrication or erection is significantly delayed due to revisions to the requirements of the contract, or for other reasons that are the responsibility of others, the Fabricator and/or Erector shall be compensated for the additional costs incurred.

**9.6. Terms of Payment**

The Fabricator shall be paid for Mill Materials and fabricated product that is stored off the job site. Other terms of payment for the contract shall be outlined in the Contract Documents.

**Commentary:**

These terms include such items as progress payments for material, fabrication, erection, retainage, performance and payment bonds and final payment. If a performance or payment bond, paid for by the Owner, is required by contract, no retainage shall be required.



## **SECTION 10. ARCHITECTURALLY EXPOSED STRUCTURAL STEEL**

### **10.1. General Requirements**

When members are specifically designated as “Architecturally Exposed Structural Steel” or “AESS” in the Contract Documents, the requirements in Sections 1 through 9 shall apply as modified in Section 10. AESS members or components shall be fabricated and erected with the care and dimensional tolerances that are stipulated in Sections 10.2 through 10.4. The following additional information shall be provided in the Contract Documents when AESS is specified:

- (a) Specific identification of members or components that are AESS;
- (b) Fabrication and/or erection tolerances that are to be more restrictive than provided for in this Section, if any; and,
- (c) Requirements, if any, of a mock-up panel or components for inspection and acceptance standards prior to the start of fabrication.

#### **Commentary:**

This Section of this Code defines additional requirements that apply only to members that are specifically designated by the Contract Documents as “Architecturally Exposed Structural Steel” (AESS). The rapidly increasing use of exposed Structural Steel as a medium of architectural expression has given rise to a demand for closer dimensional tolerances and smoother finished surfaces than required for ordinary Structural Steel framing.

This Section of this Code establishes standards for these requirements that take into account both the desired finished appearance and the abilities of the fabrication shop to produce the desired product. It should be pointed out that the term “Architecturally Exposed Structural Steel” (AESS), as covered in this Section, must be specified in the Contract Documents if the Fabricator is required to meet the fabricating standards in this Section, and applies only to that portion of the Structural Steel so identified.



AESS requirements usually involve significant cost in excess of that for Structural Steel that is fabricated in the absence of an AESS requirement. Therefore, the designation AESS should be applied rationally, with visual acceptance criteria that are appropriate for the distance at which the exposed element will be viewed in the completed structure. In order to avoid misunderstandings and to hold costs to a minimum, only those Structural Steel surfaces and Connections that will remain exposed and subject to normal view by pedestrians or occupants of the completed structure should be designated as AESS.

## 10.2. Fabrication

- 10.2.1. The permissible tolerances for out-of-square or out-of-parallel, depth, width and symmetry of rolled shapes shall be as specified in ASTM A6/A6M. Unless otherwise specified in the Contract Documents, the exact matching of abutting cross-sectional configurations shall not be necessary. The as-fabricated straightness tolerances of members shall be one-half of the standard camber and sweep tolerances in ASTM A6/A6M.
- 10.2.2. The tolerances on overall profile dimensions of members that are built-up from a series of Standard Structural Shapes, plates and/or bars by welding shall be taken as the accumulation of the variations that are permitted for the component parts in ASTM A6/A6M. The as-fabricated straightness tolerances for the member as a whole shall be one-half the standard camber and sweep tolerances for rolled shapes in ASTM A6/A6M.
- 10.2.3. Unless specific visual acceptance criteria for Weld Show-Through are specified in the Contract Documents, the members or components shall be acceptable as produced.

### **Commentary:**

Weld Show-Through is generally a function of weld size and material thickness.

- 10.2.4. All copes, miters and cuts in surfaces that are exposed to view shall



be made with uniform gaps of 1/8 in. [3 mm] if shown as open joints, or in reasonable contact if shown without gap.

10.2.5. All welds that are exposed to view shall be visually acceptable if they meet the requirements in AWS D1.1, except all groove and plug welds that are exposed to view shall not project more than 1/16 in. [2 mm] above the exposed surface. Finishing or grinding of welds shall not be necessary, unless such treatment is required to provide for clearances or fit of other components.

10.2.6. Erection marks or other painted marks shall not be made on those surfaces of weathering steel AESS members that are to be exposed in the completed structure. Unless otherwise specified in the Contract Documents, the Fabricator shall clean weathering steel AESS members to meet the requirements of SSPC-SP6.

10.2.7. Stamped or raised manufacturer's identification marks shall not be filled, ground or otherwise removed.

10.2.8. Seams of hollow structural sections shall be acceptable as produced. Seams shall be oriented away from view or as directed in the Contract Documents.

### **10.3. Delivery of Materials**

The Fabricator shall use special care to avoid bending, twisting or otherwise distorting the Structural Steel.

### **10.4. Erection**

10.4.1. The Erector shall use special care in unloading, handling and erecting the Structural Steel to avoid marking or distorting the Structural Steel. Care shall also be taken to minimize damage to any shop paint. If temporary braces or erection clips are used, care shall be taken to avoid the creation of unsightly surfaces upon removal. Tack welds shall be ground smooth and holes shall be filled with weld metal or body solder and smoothed by grinding or filing. The Erector shall plan and execute all operations in such a manner that the close fit and neat appearance of the structure will not be



impaired.

- 10.4.2. Unless otherwise specified in the Contract Documents, AESS members and components shall be plumbed, leveled and aligned to a tolerance that is one-half that permitted for non-AESS members. To accommodate these erection tolerances for AESS, the Owner's Designated Representative for Design shall specify Connections between AESS members and non-AESS members, masonry, concrete and other supports as Adjustable Items, in order to provide the Erector with means for adjustment.

When AESS is backed with concrete, the Owner's Designated Representative for Construction shall provide sufficient shores, ties and strongbacks to prevent sagging, bulging or similar deformation of the AESS members due to the weight and pressure of the wet concrete.



**AMERICAN INSTITUTE OF STEEL CONSTRUCTION, INC.**  
One East Wacker Drive, Suite 3100, Chicago, Illinois 60601-2001

Pub. No. S303 (20M500)



## CONSTRUCTION INDUSTRY ORGANIZATIONS

This section contains a listing of private organizations, government related organizations, and foreign organizations that are potential sources for technical information for those engaged in steel design, detailing, fabrication, erection, project management, and building operation.

The following is a summary of the organizations. Statements that appear in the text of this section were provided in whole or in part by the respective organizations.

### PRIVATE AND NON-GOVERNMENT RELATED AGENCIES

Aluminum Association, Inc. (AA)

American Concrete Institute (ACI)

American Galvanizers Association (AGA)

American Institute for Hollow Structural Sections (AIHSS)

American Institute of Architects (AIA)

American Institute of Mining, Metallurgical, and Petroleum Engineers (AIME)

American Institute of Steel Construction (AISC)

American Institute of Timber Construction (AITC)

American Iron and Steel Institute (AISI)

American National Standards Institute (ANSI)

American Nuclear Society (ANS)

American Petroleum Institute (API)

American Railway Engineering and Maintenance-Of-Way Association (AREMA)

American Society for Metals International (ASMI)

American Society for Nondestructive Testing (ASNT)

American Society for Testing and Materials (ASTM)

American Society of Civil Engineers (ASCE)

American Society of Mechanical Engineers (ASME)

American Water Works Association (AWWA)

American Welding Institute (AWI)

American Welding Society (AWS)

American Zinc Association (AZA)

Association of American Railroads (AAR)

Association of Iron and Steel Engineers (AISE)

Building Officials and Code Administrators International (BOCA)



Concrete Reinforcing Steel Institute (CRSI)  
Construction Specifications Institute (CSI)  
Corrugated Steel Pipe Institute (CSPI)  
Crane Manufacturers Association of America (CMAA)  
Electronic Industries Alliance (EIA)  
United Engineering Foundation  
Factory Mutual Engineering and Research Company  
Gypsum Association  
Indiana Limestone Institute of America, Inc. (ILI)  
Industrial Fasteners Institute (IFI)  
Institute of the Ironworking Industry (III)  
International Conference of Building Officials (ICBO)  
Iron and Steel Society (ISS)  
James F. Lincoln Arc Welding Foundation (JLWF)  
Light Gauge Steel Engineers Association (LGSEA)  
Material Handling Industry (MHI)  
Materials Properties Council  
Metal Building Manufacturers Association (MBMA)  
Metal Construction Association (MCA)  
Metal Roofing Alliance (MRA)  
Metals Service Center Institute (MSCI)  
National Association of Architectural Metals Manufacturers (NAAMM)  
National Association of Corrosion Engineers (NACE)  
National Concrete Masonry Association (NCMA)  
National Corrugated Steel Pipe Association (NCSPA)  
National Erectors Association (NEA)  
National Fire Protection Association (NFPA)  
National Fire Sprinkler Association (NFSA)  
National Institute of Steel Detailing (NISD)  
Nickel Development Institute (NiDI)  
North American Steel Framing Alliance (NASFA)





Portland Cement Association (PCA)  
Post-Tensioning Institute (PTI)  
Prestressed Concrete Institute (PCI)  
Southern Building Code Congress International (SBCCI)  
Steel Deck Institute (SDI)  
Steel Erectors Association of America (SEAA)  
Steel Joist Institute (SJI)  
Steel Plate Fabricators Association (SPFA)  
Steel Recycling Institute (SRI)  
Society for Protective Coatings (SSPC)  
Steel Tank Institute (STI)  
Steel Tube Institute of North America (STI)  
Structural Stability Research Council (SSRC)  
Underwriters Laboratories Inc. (UL)  
Welding Research Council (WRC)

## **FEDERAL AND STATE GOVERNMENT AND RELATED AGENCIES**

Army Corps of Engineers  
American Association of State Highway and Transportation Officials (AASHTO)  
Bureau of Labor Statistics  
Department of Housing and Urban Development (HUD)  
Environmental Protection Agency (EPA)  
Federal Construction Council (FCC)  
Federal Highway Administration (FHA)  
Federal Railroad Administration  
General Services Administration (GSA)  
National Institute of Building Sciences (NIBS)  
National Institute of Standards and Technology (NIST)  
National Science Foundation (NSF)  
National Technical Information Service (NTIS)  
Occupational Safety and Health Administration (OSHA)



## FOREIGN ORGANIZATIONS

Australian Institute of Steel Construction (AISC)  
British Constructional Steelwork Association (BCSA)  
Canadian Institute of Steel Construction (CISC)  
Canadian Sheet Steel Building Institute (CSSBI)  
European Convention for Constructional Steelwork (ECCS)  
Japanese Society of Steel Construction (JSSC)  
Mexican Institute of Steel Construction (MISC)  
South African Institute of Steel Construction (SAISC)

## PRIVATE AND NON-GOVERNMENT RELATED AGENCIES

### **Aluminum Association, Inc. (AA)**

900 19th Street, N.W., Washington, DC 20006  
(202) 862-5100  
(202) 862-5164 (fax)  
[www.aluminum.org](http://www.aluminum.org)

The Aluminum Association (AA) is the trade association for domestic producers of primary and secondary aluminum and semi-fabricated aluminum products. Member companies operate 300 plants in 40 states.

### **American Concrete Institute (ACI)**

ACI International, P.O. Box. 9094 Farmington Hills, MI 48333  
(248) 848-3700  
(248) 848-3701  
[www.aci-int.org](http://www.aci-int.org)

The American Concrete Institute (ACI) is a non-profit organization which represents the public agency, engineer, architect, owner, contractor, educator, or other specialist interested in the design, construction, or maintenance of concrete structures.

### **American Galvanizers Association (AGA)**

6881 South Holly Circle, Suite 108, Englewood, CO 80112  
(800) H OT SPEC or (720) 554-0900  
(720) 554-0909 (fax)  
[www.galvanizeit.org](http://www.galvanizeit.org)

The American Galvanizers Association (AGA) promotes corrosion prevention through the use of post-fabrication hot-dip galvanizing. The AGA produces over 50 different publications, videos, and slide programs discussing various aspects of galvanizing for long-term corrosion prevention. These materials are provided at no charge to specifiers. Other complimentary services include educational seminars and the 1-800-HOT-SPEC line for answering questions about galvanizing and its applications. The AGA represents galvanizing companies in the United States, Canada, Mexico, and 18 other countries.

**American Institute for Hollow Structural Sections (AIHSS)**

The American Institute for Hollow Structural Sections (AIHSS) is a non-profit technical organization committed to advancing and improving the use of structural steel tubing and pipe in buildings, bridges, and special structures. AIHSS encourages knowledgeable decisions concerning hollow structural sections in construction applications through the development and publication of engineering data and design aids, seminars, research and development, and specifications and standards activities. Among its publications are HSS/Structural Steel Tubing-Dimensions and Section Properties, HSS-Column Load Tables, and HSS-Beam Load Tables.

**American Institute of Architects (AIA)**

1735 New York Avenue, N.W., Washington, DC 20006  
(202) 626-7300 or (800) AIA-3837  
(202) 626-7547 (fax)  
[www.aia.org](http://www.aia.org)

Since 1857, The American Institute of Architects has represented the professional interests of America's architects. The AIA works to meet the needs and interests of the nation's architects and the public they serve by developing public awareness in the value of architecture and the importance of good design. In partnership with The American Architectural Foundation, the AIA strives for a national design literacy in the belief that a well-trained, creative profession and an informed public are prerequisites for a community's quality of life.

**American Institute of Mining, Metallurgical, and Petroleum Engineers (AIME)**

Three Park Avenue, New York NY 10016  
(212) 419-7676  
(212) 419-7671(fax)  
[www.aimeny.org](http://www.aimeny.org)

Constituent societies of AIME include the Iron and Steel Society (see separate entry), the Society of Petroleum Engineers, the Society of Mining Engineers, and the Minerals, Metals, and Materials Society.

**American Institute of Steel Construction (AISC)**

One East Wacker Drive, Suite 3100, Chicago, IL 60601-2001  
(312) 670-2400  
(312) 670-5403 (fax)  
[www.aisc.org](http://www.aisc.org)

The American Institute of Steel Construction (AISC) is a non-profit trade association representing and serving the fabricated structural steel industry as well as engineers practicing structural steel design in the United States. For over 70 years, its purpose has been to advance the technology and competitiveness of steel construction through standardization, research and development, education, technical assistance, and quality control. AISC's programs include: the development of specifications and technical publications, research, technical and management seminars, engineering fellowships, and programs for quality control, productivity, and safety. AISC represents the combined experience, judgment, and strength of the steel fabricating industry and the structural engineering design profession.

**American Institute of Timber Construction (AITC)**

7012 S. Revere Parkway, Suite 140, Englewood, CO 80112  
(303) 792-9559  
(303) 792-0669 (fax)  
[www.aitc-glulam.org](http://www.aitc-glulam.org)



The American Institute of Timber Construction (AITC) is the oldest national technical trade association of the structural glued-laminated (glulam) timber industry. AITC was formed in 1952 to further the development, production, and promotion of laminated timber systems through the application of sound engineering practices and research. AITC has established design and product standards and developed industry quality control and inspection procedures that help assure economical, efficient, and reliable performance in structural applications.

**American Iron and Steel Institute (AISI)**

1101 17th Street, N.W., Suite 1300, Washington, DC 20036-4700  
(202) 452-7100  
(202) 463-6573 (fax)  
www.steel.org

The American Iron and Steel Institute (AISI) is a non-profit association of companies and individuals in the Western Hemisphere engaged in the iron and steel industry. The Construction Marketing Committee promotes the use of steel buildings, bridges, pipe/tank, and construction products through research, education, and promotion programs. The Committee on Construction Codes and Standards oversees efforts to achieve competitive provisions in applicable building codes and standards. AISI publishes the Specification for the Design of Cold-Formed Steel Structural Members.

**American National Standards Institute (ANSI)**

Headquarters, 1819 L Street, N.W. 6th Floor, Washington, DC 20036  
(202) 293-8020  
(202) 293-9287 (fax)  
www.ansi.org

The American National Standards Institute (ANSI) is a private non-profit membership organization that coordinates the United States voluntary standards system, bringing together interests from the private and public sectors to develop voluntary standards for a wide array of United States industries. ANSI is the official United States member body to the world's leading standards bodies: the International Organization for Standardization (ISO) and the International Electrotechnical Commission (IEC), via the United States National Committee (USNC).

**American Nuclear Society (ANS)**

555 N. Kensington Avenue, LaGrange Park, IL 60526  
(708) 352-6611  
(708) 352-0499 (fax)  
www.ans.org  
(<http://www.ans.org/about/>)

The American Nuclear Society is a not-for-profit, international, scientific and educational organization. It was established by a group of individuals who recognized the need to unify the professional activities within the diverse fields of nuclear science and technology. December 11, 1954, marks the Society's historic beginning at the National Academy of Sciences in Washington, D.C. ANS has since developed a multifarious membership composed of approximately 11,000 engineers, scientists, administrators, and educators representing 1,600 plus corporations, educational institutions, and government agencies. It is governed by three officers and a board of directors elected by the membership.

**American Petroleum Institute (API)**

1220 L Street, N.W., Washington, DC 20005  
(202) 682-8000  
(202) 962-4739(fax)  
www.api.org



The American Petroleum Institute (API), founded in 1919, is a non-profit corporation that represents the domestic petroleum industry. Its membership consists of a broad cross section of the petroleum and allied industries, including such functional segments as exploration, production, transportation, refining, and marketing.

**American Railway Engineering and Maintenance-Of-Way Association (AREMA)**

8201 Corporate Drive, Suite 1125, Landover, MD 20785  
(301) 459-3200  
(301) 459-8077 (fax)  
www.arema.org

American Railway Engineering and Maintenance-Of-Way Association (AREMA) is a professional organization concerned with engineering and maintenance work on railways in North America. It covers the track and bridge aspects of railroading, as well as roadbed, electrification, scales, and the mechanics of track maintenance machinery. AREMA's twenty-two technical committees determine the content of the Manual for Railway Engineering. This standard reference in its field is revised annually to reflect the latest field-proven procedures and designs for railway engineering.

**American Society for Metals International (ASMI)**

9639 Kinsman Road, Materials Park, OH 44073-0002  
(440) 338-5151 or (800) 336-5152  
(440) 338-4634 (fax)  
www.asm-intl.org  
(www.asm-intl.org)

ASM International is the society for materials engineers and scientists, a worldwide network dedicated to advancing industry, technology and applications of metals and materials.

**American Society for Nondestructive Testing (ASNT)**

P.O. Box 28518, 1711 Arlingate Lane, Columbus, OH 43228-0518  
(614) 274-6003 or (800) 222-2768  
(614) 274-6899 (fax)  
www.asnt.org  
(<http://www.asnt.org/whatasnt/whatasnt.htm>)

The American Society for Nondestructive Testing, Inc. (ASNT) is the world's largest technical society for nondestructive testing (NDT) professionals. Through our organization and membership, we provide a forum for exchange of NDT technical information; NDT educational materials and programs; and standards and services for the qualification and certification of NDT personnel. ASNT promotes the discipline of NDT as a profession and facilitates NDT research and technology applications.

**American Society for Testing and Materials (ASTM)**

100 Barr Harbor Drive, West Conshohocken PA, 19428-2959  
(610) 832-9585  
(610) 832-9555 (fax)  
www.astm.org

Organized in 1898, ASTM has grown into one of the world's largest voluntary, full-consensus standards development organizations. From the work of 132 technical standards-writing committees, ASTM publishes standard testing methods, specifications, practices, guides, classifications, and terminology for materials, products, systems, and services. Related scientific and technical information is also published in various books and journals. ASTM's activities encompass metals, paints, plastics, textiles, petroleum, construction, energy, the environment, consumer products, medical services and devices, electronics, and many other areas. Technical research and



testing is performed voluntarily by 34,000 members worldwide. Almost 9,000 standards are published each year in the 69 volumes of the Annual Book of ASTM Standards. These standards and related information are widely used and accepted throughout the world.

#### **American Society of Civil Engineers (ASCE)**

World Headquarters, 1801 Alexander Bell Drive, Reston, VA 20191-4400  
(800) 548-ASCE or (703)-295-6300  
(703) 295-6222 (fax)  
[www.asce.org](http://www.asce.org)

The mission of the American Society of Civil Engineers is to advance professional knowledge and improve the practice of civil engineering in service to humanity by: improving the quality of life worldwide; developing and promoting standards of excellence; providing life-long education for civil engineers; serving members' needs, to meet the challenges at the frontiers of developing technology and societal change. The building load standard ASCE-7 is one of several that ASCE produces.

#### **American Society of Mechanical Engineers (ASME)**

ASME International, Three Park Ave. New York, NY 10016-5990  
(212) 591-7722 or (800) THE-ASME  
(212) 591-7674 (fax)  
[www.asme.org](http://www.asme.org)

The American Society of Mechanical Engineers (ASME) is a non-profit educational and technical organization. Founded in 1880, ASME serves its members, industry, and government by encouraging the development of new technologies and finding solutions to the problems of an increasingly global technological society. Its programs include publishing, technical conferences and exhibits, engineering education, government relations, and public education, as well as the development of codes and standards.

#### **American Water Works Association (AWWA)**

6666 West Quincy Avenue, Denver, CO 80235-3098  
(303) 794-7711  
(303) 794-7310 (fax) or (303) 794-8915 (fax)  
[www.awwa.org](http://www.awwa.org)

The American Water Works Association (AWWA) is composed of over 54,000 professionals and 4,000 companies in the water supply field. AWWA is dedicated to the promotion of public health and welfare by assuring drinking water of unquestionable quality and sufficient quantity. As a leader for the public drinking water profession, AWWA is an effective instrument of education and change, setting standards, and advancing technology, science, and governmental policies relative to the management, collection, storage, treatment, and distribution of public water supplies.

#### **American Welding Institute (AWI)**

The American Welding Institute (AWI) is a member owned non-profit organization. AWI promotes quality improvement, along with productivity, as top priorities for the United States welding industry. The mission of AWI is to put America's best ideas about welding to productive use in American industry. AWI provides services to the welding industry including welding engineering, equipment evaluation, mechanical testing, customized software, onsite trouble-shooting, metallurgical analysis, specialized training, and failure analysis.

#### **American Welding Society (AWS)**

550 N.W. LeJeune Road, P.O. Box 351040, Miami, FL 33135  
(305) 443-9353 or (800) 443-9353  
(305) 443-7559 (fax)  
[www.aws.org](http://www.aws.org)



The American Welding Society (AWS) provides services to its members and the industry that advance the science, technology, and applications of welding and materials joining throughout the world. In its leadership role, AWS is recognized as the authority on joining technology and the source for coordinating matters pertaining to codes, standards, materials, education, certification, and research. Services include the AWS International Welding Exposition, publishing the Welding Journal, developing and publishing consensus standards, and offering a broad range of educational and welding certification programs.

**American Zinc Association (AZA)**

1112 Sixteenth Street NW, Suite 240, Washington DC 20036  
(202) 835 0164  
(202) 835-0155  
[www.zinc.org](http://www.zinc.org)

The American Zinc Association is a Washington, D.C. based trade organization comprised of primary and secondary producers of zinc metal, zinc oxide and zinc dust marketed in the United States. AZA is the voice for zinc in the United States-- the world's largest single-country market. Through active public policy and public relations programs, AZA seeks to influence the development of legislation and regulations which impact zinc and to educate the public and key audience about the metal.

**Association of American Railroads (AAR)**

50 F Street NW, Washington, DC 20001  
(202) 639-2100  
(202) 639-2558 (fax)  
[www.aar.org](http://www.aar.org)

**Association of Iron and Steel Engineers (AISE)**

Three Gateway Center, Suite 1900, Pittsburgh, PA 15222-1097  
(412) 281-6323  
(412) 281-4657 (fax)  
[www.aise.org](http://www.aise.org)

The Association of Iron and Steel Engineers (AISE) is a technical society serving the steel industry worldwide through the collection and dissemination of technical information relating to the production of iron and steel. This is accomplished through a monthly technical journal, national conventions, local and regional meetings, technical publications, equipment specifications, a biennial industrial trade show, and technical committees which represent both user and supplier. Founded in 1907, AISE has developed into a multi-disciplined organization with over 10,000 members covering all phases of steel industry operations.

**Building Officials and Code Administrators International (BOCA)**

4051 West Flossmoor Road, Country Club Hills, IL 60478-5795  
(708) 799-2300 or (800) 214-4321  
(708) 799-4981 (fax)  
[www.bocai.org](http://www.bocai.org)

Building Officials and Code Administrators (BOCA) International, Inc., is a not-for-profit organization which publishes the National Building Code. Founded in 1915, BOCA International is the original professional association of construction code officials. The organization was specifically established to provide a forum for the exchange of knowledge and ideas concerning building safety and construction regulation. BOCA came into being because its founders had a desire for excellence and professionalism in code enforcement. Today, BOCA offers a wide variety of membership services to promote code professionalism. The organization maintains ongoing model code development activity, conducts regular training and education programs, offers a wide variety of model con-



struction codes and code-related publications, provides code interpretation assistance to members, and provides various other code-related services in the public interest.

**Concrete Reinforcing Steel Institute (CRSI)**

933 North Plum Grove Road, Schaumburg, IL 60173-4758  
(847) 517 1200  
(847) 517-1206 (fax)  
www.crsi.org

The Concrete Reinforcing Steel Institute represents reinforcing steel producers and fabricators, epoxy coating applicators and powder manufacturers, and suppliers of other products used in concrete construction and fabricating equipment manufacturing. Technical activities are conducted by the CRSI Engineering Practice Committee and subcommittees on bar supports, placing reinforcing bars, concrete joist construction, detailing reinforced concrete, epoxy coating, and splicing reinforcing steel.

**Construction Specifications Institute (CSI)**

99 Canal Center Plaza, Suite 300, Alexandria, VA 22314-1791  
(703) 684-0300 or (800) 689-2900  
(703) 684-0465 (fax)  
www.csinet.org

The Construction Specifications Institute (CSI), founded in 1948, is a not-for-profit organization dedicated to the advancement of construction technology through communication, education, research, and service. CSI serves the interest of architects, engineers, specifiers, contractors, product manufacturers, and others in the construction industry.

**Corrugated Steel Pipe Institute (CSPI)**

652 Bishop Street N., Unit 2A, Cambridge, Ontario, Canada, N3H 4V6  
(519) 650-8080  
(519) 650-8081 (fax)  
www.cspi.ca

The Corrugated Steel Pipe Institute (CSPI) was formed in 1961 to promote wider use of corrugated steel pipe and corrugated structural plate structures for drainage and other uses across Canada. CSPI provides product information, recommends standards and specifications, and recommends practices in the design, selection, application, and installation of corrugated steel pipe. CSPI provides liaison with the Canadian Standards Association, the National Corrugated Steel Pipe Association, and the American Iron and Steel Institute.

**Crane Manufacturers Association of America (CMAA)**

8720 Red Oak Boulevard, #201, Charlotte, NC 28217  
(704) 676-1190  
(704) 676-1199 (fax)  
([http://www.mhia.org/psc/PSC\\_Products\\_Cranes.cfm](http://www.mhia.org/psc/PSC_Products_Cranes.cfm))

CMAA is the Crane Manufacturers Association of America, Inc., an independent trade association affiliated with the United States Division of Material Handling Industry. The voluntary association of CMAA members has existed since 1955. Member companies represent industry leaders in the overhead crane market.

**Electronic Industries Alliance (EIA)**

2500 Wilson Blvd., Arlington, VA 22201  
(703) 907-7500  
www.eia.org





For more than 68 years, the Electronic Industries Alliance (EIA) has been the national trade organization representing the United States electronics manufacturers. Committed to the competitiveness of the American producer, EIA represents the entire spectrum of companies involved in the manufacture of electronic components, parts, systems, and equipment for communications, industrial, government, and consumer-end uses.

**United Engineering Foundation**

Three Park Ave. 27th Floor, New York, NY 10016  
(212) 591-7836  
(212) 591-7441 (fax)  
[www.uefoundation.org/](http://www.uefoundation.org/)

**Factory Mutual Engineering and Research Company**

1151 Boston-Providence Turnpike, Norwood, MA 02062  
(781) 762-4300  
(781) 762-9375 (fax)

**Gypsum Association**

810 First Street NE, #510, Washington, DC 20002  
(202) 289-5440  
(202) 289-3707  
[www.gypsum.org](http://www.gypsum.org)  
([www.gypsum.org](http://www.gypsum.org))

The Gypsum Association is a not-for-profit trade association established in 1930. To be eligible for membership, a firm or individual must manufacture gypsum board. The Gypsum Association is located in Washington DC. It represents manufacturers of gypsum board in the U.S. and Canada and provides technical information and assistance to the construction industry and code enforcement community regarding gypsum board.

**Indiana Limestone Institute of America, Inc. (ILI)**

400 Stone City Bank Bldg., Bedford, Indiana 47421  
(812) 275-4426  
(812) 279-8682 (fax)  
[www.ili.ai.com](http://www.ili.ai.com)  
([www.ili.ai.com](http://www.ili.ai.com))

The Indiana Limestone Institute of America, Inc. serves the construction industry as a coordinating agency for the dissemination of accurate, unbiased information on limestone standards, recommended practices, grades, colors, finishes, and all technical data required for specifying, detailing, fabricating and erecting Indiana Limestone. ILI will assist architects, contractors, and building owners in solving design problems and in all questions relating to best usage, maintenance and other matters.

**Industrial Fasteners Institute (IFI)**

East Ohio Building, Suite 1105, 1717 East Ninth Street, Cleveland, OH 44114-2879  
(216) 241-1482  
(216) 241-5901 (fax)  
[www.industrial-fasteners.org](http://www.industrial-fasteners.org)

The Industrial Fasteners Institute (IFI) is an association of North American manufacturers of bolts, nuts, screws, rivets, and special formed parts. IFI members combine their technical knowledge to advance the technology and application engineering of fasteners and formed parts through planned programs of research and education. IFI and its members work closely with leading national and international technical organizations in developing standards and other technical practices. IFI is comprised of 90 fastener manufacturers and 35 suppliers of goods and services commonly used in the manufacture of fasteners.

**Institute of the Ironworking Industry (III)**

1750 New York Avenue N.W., Suite 400, Washington, DC 20006  
(202) 783-3998  
(202) 393-1507 (fax)

The Institute of the Ironworking Industry (III) is a non-profit labor-management trade association representing over 8,500 erection firms and 150,000 ironworkers. A board of directors equally apportioned from management and the Ironworkers International Union (AFL-CIO) sets policy to develop ways of eliminating problems which reduce the competitiveness and inhibit the economic development of the erection industry in the United States and Canada. Cooperation with other associations related to steel construction is encouraged to enhance safety, productivity, and the quality of the delivered product.

**International Conference of Building Officials (ICBO)**

5360 Workman Mill Road, Whittier, CA 90601-2258  
(913) 764-2272  
(310) 692-3853 (fax)  
[www.icbo.org](http://www.icbo.org)

The International Conference of Building Officials is dedicated worldwide to public safety in the built environment through the development, maintenance, and promotion of uniform codes and standards, enhancement of professionalism in code administration, and the facilitation of the acceptance of innovative building products and systems. The Conference works toward these objectives through the publication of the Uniform Building Code and its associated family of codes and standards and through the offering of high quality training, technical assistance, and certification examinations based on these documents.

**Iron and Steel Society (ISS)**

186 Thorn Hill Road, Warrendale, PA 15086-7528  
(724) 776-1535  
(724) 776-0430 (fax)  
[www.iss.org](http://www.iss.org)

The Iron and Steel Society (ISS) is a constituent society of the American Institute of Mining, Metallurgical, and Petroleum Engineers (AIME). ISS members are active in the field of iron and steel processing and technology. ISS provides a medium of communication and cooperation among those interested in any phase of ferrous metallurgy and materials science and technology.

**James F. Lincoln Arc Welding Foundation (JFLF)**

22801 St. Clair, P.O. Box 17035, Cleveland, OH 44117-0035  
(216) 481-8100  
(216) 486-1751 (fax)  
[www.lincolnelectric.com](http://www.lincolnelectric.com)

The James F. Lincoln Arc Welding Foundation, incorporated as a non-profit entity in 1936, is the only organization in the United States specifically dedicated to educating the public about the art and science of arc welding. The Lincoln Foundation recognizes technical achievement with substantial monetary awards and publishes educational materials for dissemination to the public. International Assistant Secretaries now carry out Lincoln Foundation programs in Argentina, Australia, Canada, Croatia, Hungary, Japan, New Zealand, the People's Republic of China, Russia, Southern Africa, and the United Kingdom.

**Light Gauge Steel Engineers Association (LGSEA)**

1726 M. Street, N.W., Suite 601 Washington, D.C. 20036  
(202) 263-4488  
(202) 785-3856 fax  
[www.lgsea.com](http://www.lgsea.com)

The Light Gauge Steel Engineers Association (LGSEA) was formed in 1994 to build a national network of architects and engineers knowledgeable in efficient steel framing design, and to resolve technical issues related to steel framing and then deliver those solutions to the marketplace. We are accomplishing these objectives through publications and educational programs produced through the combined expertise of the world's foremost leaders in research, structural design, and fabrication of products for the light gauge steel framing industry.

**Material Handling Industry (MHI)**

8720 Red Oak Boulevard, Suite 201, Charlotte, NC 28217  
(704) 676-1190  
(704) 676-1199 (fax)  
[www.mhia.org](http://www.mhia.org)  
([www.mhia.org/about/](http://www.mhia.org/about/))

Material Handling Industry of America (MHIA) is the non-profit organization under which domestic and international activities are conducted. Active members are manufacturers of industrial material handling equipment and systems, or user-specified components for such equipment. They market their products in the United States. Associate membership is held by business, publications, consultants and systems simulators.

**Materials Properties Council**

Three Park Ave. 27th Floor, New York, NY 10016  
(212) 591-7693  
(212) 591-7183 (fax)  
[www.forengineers.org](http://www.forengineers.org)

**Metal Building Manufacturers Association (MBMA)**

1300 Sumner Avenue, Cleveland, OH 44115-2851  
(216) 241-7333  
(216) 241-0105 (fax)  
[www.mbma.com](http://www.mbma.com)

The Metal Building Manufacturers Association (MBMA) was formed in 1956 with the goal of developing sound design criteria for verifying the performance of structures under various loads. MBMA has promoted the benefits of metal building systems to building code officials, architects, and engineers. MBMA has 27 member manufacturing firms that employ 10,000 persons and operate 57 manufacturing facilities in 24 states and three foreign countries.

**Metal Construction Association (MCA)**

[www.mca1.org](http://www.mca1.org)

The Metal Construction Association (MCA) was established in 1983 to promote the wider use of metal in construction. MCA programs include education, industry advertising, and technical service through the development of guidelines, statistics, and specifications. Membership is open to all firms and individuals with an interest in the metal construction industry. MCA holds two membership meetings each year, in January and August. In addition, the Association sponsors the only industry-wide trade show for metal in construction, Metalcon International.

**Metal Roofing Alliance (MRA)**

3309 56th Street NW, Suite 105 Gig Harbor, WA 98335  
(253) 858-0233  
(216) 241-0105 (fax)  
[www.metalroofing.com](http://www.metalroofing.com)

The result of more than three years of planning by industry leaders, we launched The Metal Roofing Alliance (MRA) in 1998. We're a coalition of metal roofing manufacturers, paint suppliers and coaters, dealers, associations and related companies whose purpose is to educate the public about the many benefits of residential metal roofing.

**Metals Service Center Institute (MSCI)**

8550 Bryn Mawr Suite 550, Chicago, IL 60631  
(773) 867-1300  
(773) 867-8750 (fax)  
[www.msci.org](http://www.msci.org)

The Metals Service Center Institute (MSCI) was established in 1907 to enhance the financial return of member companies by providing information, education, governmental representation, networking opportunities, and a forum to enhance the quality of products and services in meeting customer, supplier, and employee expectations. Steel service centers purchase basic steel products, add value to them through services such as inventory management, pre-production processing, just-in-time delivery, electronic data interchange, and barcoding, and subsequently sell production-ready metal pieces and parts to manufacturers. Producing mills are Associate Members. International members are welcome.

**National Association of Architectural Metals Manufacturers (NAAMM)**

Association Headquarters, 8 South Michigan Ave., Suite 1000, Chicago, IL 60603  
(312) 332-0405  
(312) 332-0706 (fax)  
[www.naamm.org](http://www.naamm.org)

The National Association of Architectural Metal Manufacturers (NAAMM) is the Chicago-based trade association representing manufacturers of metal products. NAAMM develops, maintains, and publishes technical information on products from members in its five divisions: Architectural Metals Products Division (metal stairs, railing systems, and miscellaneous and ornamental products), Flagpole Division, Hollow Metal Manufacturers Association Division (hollow metal doors and frames), Metal Bar Grating Division, and Metal Lath/Steel Framing Association Division.

**National Association of Corrosion Engineers (NACE)**

1440 S. Creek Dr., Houston, TX 77084-4906  
(281) 228-6200  
(281) 228-6300 (fax)  
[www.nace.org](http://www.nace.org)

NACE develops and distributes high-quality technology to prevent and control degradation of materials in engineered systems. NACE promotes: (1) the application of all materials, e.g., metals, polymers, concrete, ceramics, natural materials, composites, and electronic materials; (2) the integration of all degradation phenomena, e.g., corrosion, wear, and fracture; and, (3) the integration of corrosion science and engineering into the design process. NACE is a professional association with more than 16,000 members across many industries. Programs include professional recognition and certification, education, training, seminars, committee work weeks, and an annual conference. NACE also publishes two monthly journals, standards, books, and computer software.

**National Concrete Masonry Association (NCMA)**

13750 Sunrise Valley Dr., Herndon, VA 20171  
(703) 713-1900  
(703) 713-1910 (fax)  
www.ncma.org  
(www.ncma.org/)

The National Concrete Masonry Association (NCMA), established in 1918, is the national trade association representing the concrete masonry industry. The Association is involved in a broad range of technical, research, marketing, government relations and communications activities. NCMA is an association of producers of concrete masonry products, and suppliers of products and services related to the industry. NCMA offers a variety of technical services and design aids through publications, computer programs, slide presentations and technical training.

**National Corrugated Steel Pipe Association (NCSPA)**

1255 Twenty-third St., NW Washington, DC 20037-1174  
(202) 452-1700  
(202) 833-3636 (fax)  
www.ncspa.org

The National Corrugated Steel Pipe Association (NCSPA) was founded in 1956 to promote sound public policy relating to the use of corrugated steel drainage structures in private and public construction. The association collects and distributes technical information, assists in the formulation of specifications and designs, and conducts seminars to increase the awareness of the product. Among publications are Design Data Sheets, Drainage Technology Bulletins, two installation manuals, and two cost analyses of pipe materials.

**National Erectors Association (NEA)**

1501 Lee Highway, Suite 202, Arlington, VA 22209  
(703) 524-3336  
(703) 524-3364 (fax)

The National Erectors Association (NEA) is a national trade association of union contractors dedicated to providing its members with the highest level of labor relations and safety services, the promotion of positive labor-management programs in construction, and the advancement of a dynamic union construction industry. Membership includes steel erectors, industrial maintenance contractors, specialty contractors, general contractors, and construction managers. Active standing committees include its nationally-known Labor Committee and Safety & Health Committee.

**National Fire Protection Association (NFPA)**

1 Batterymarch Park, P.O. Box 9101, Quincy, MA 02269-9101  
(617) 770-3000  
(617) 770-0700 (fax)  
www.nfpa.org

The National Fire Protection Association (NFPA), an international non-profit organization, is recognized as the premier institution dedicated exclusively to protecting lives and property from fire and related hazards. NFPA publishes over 270 nationally recognized codes and standards, as well as numerous fire service training and educational programs. More than 62,500 members work voluntarily to further NFPA's mission.

**National Fire Sprinkler Association (NFSA)**

Robin Hill Corporate Park, Route 22, P.O. Box 1000, Patterson, NY 12563  
(845) 878-4200 Ex. 133  
(845) 878-4215 (fax)  
[www.nfsa.org](http://www.nfsa.org)

**National Institute of Steel Detailing (NISD)**

7700 Edgewater Drive, Suite 670, Oakland, CA 94621  
(510) 568-3741  
(510) 568-3781 (fax)  
[www.nisd.org](http://www.nisd.org)

The National Institute of Steel Detailing (NISD) was formed in 1969 to create a better understanding and bond between individuals engaged in the detailing profession. NISD strives to eliminate practices which are injurious, to promote the efficiency of their work, and to uphold the proper standards for the steel detailer in relations with other members of the construction industry. The institute is a non-profit association of regional chapters, firms, and individuals in the United States who serve the fabricated structural and miscellaneous steel industry.

**Nickel Development Institute (NiDI)**

214 King Street, Suite 510, Toronto, Ontario, Canada M5H 3S6  
(416) 591-7999  
(416) 591-7987 (fax)  
[www.NiDI.org](http://www.NiDI.org)

The Nickel Development Institute (NiDI) provides technical service to nickel consumers and others concerned with nickel/nickel alloys and their uses. NiDI's information services are available to designers, specifiers, and educators as well as nickel users. Inquiries are welcomed from architects, engineers, specification writers, and others responsible for selection of materials for manufacturing and construction. NiDI looks forward to cooperating with colleges and universities by furnishing relevant information and materials for engineering, materials science, and industrial design education.

**North American Steel Framing Alliance (NASFA)**

1726 M Street, NW, Suite 601, Washington, DC 20036-4523  
(202) 785-2022  
(202) 785-3856 (fax)  
[www.nasfa.org](http://www.nasfa.org)

The North American Steel Framing Alliance (NASFA) is an organization that was established by the American Iron and Steel Institute in 1998 to rapidly accelerate the use of light gauge steel framing in residential construction.

**Portland Cement Association (PCA)**

5420 Old Orchard Road, Skokie, IL 60077-1083  
(847) 966-6200  
(847) 966-8389 (fax)  
[www.apca.org](http://www.apca.org)

**Post-Tensioning Institute (PTI)**

1717 West Northern Avenue, Suite 114, Phoenix, AZ 85021  
(602) 870-7540  
(602) 870-7541 (fax)  
[www.post-tensioning.org](http://www.post-tensioning.org)

The Post-Tensioning Institute, a not-for-profit organization, provides research, technical development, marketing, and promotional activities for companies engaged in post-tensioned prestressed construction. Its publications are



a major communications system for disseminating information on p/t design and construction technology. In addition, PTI publishes a quarterly newsletter dealing with developments in the p/t industry. Members include p/t materials fabricators, manufacturers of prestressing materials, companies supplying miscellaneous materials, services, and equipment used in p/t construction, and more than 700 professional engineers, architects, and contractors.

**Prestressed Concrete Institute (PCI)**

175 W. Jackson Street, Chicago, IL 60604  
(312) 786-0300  
(312) 786-0353 (fax)  
[www.pci.org](http://www.pci.org)

**Society for Protective Coatings (SSPC)**

40 24th Street, 6th Floor, Pittsburgh, PA 15222-4656  
(412) 281-2331 or (877) 281-7772  
(412) 281-9992 (fax)  
[www.sspc.org](http://www.sspc.org)

SSPC was founded in 1950 as the Steel Structures Painting Council, a non-profit professional society concerned with the use of coatings to protect industrial steel structures. Renamed as The Society for Protective Coatings, SSPC serves its members and advances the industry through standards, regulatory advocacy, education, and information exchange.

**Southern Building Code Congress International (SBCCI)**

900 Montclair Road, Birmingham, AL 35213-1206  
(205) 591-1853  
(205) 591-0775 (fax)  
[www.sbcci.org](http://www.sbcci.org)

The Southern Building Code Congress International, Inc. (SBCCI) was established in 1940 as a membership organization dedicated to promulgating and maintaining a comprehensive set of model building codes and to providing support services to users of the code. It continues that tradition today with the Standard Codes™ which cover every aspect of commercial and residential construction. The SBCCI also provides technical and educational services to assist code enforcement professionals and others in providing the most efficient, effective, and skilled service to the building industry.

**Steel Deck Institute (SDI)**

P.O. Box 25, Fox River Grove, IL 60021-0025  
(847) 462-1930  
(847) 462 1940 (fax)  
[www.sdi.org](http://www.sdi.org)

Since 1939, the Steel Deck Institute (SDI) has provided uniform industry standards for the engineering, design, manufacture, and field usage of steel decks. The SDI is concerned with cold-formed steel products, with various configurations distinctive to individual manufacturers, used to support finished roofing materials, or to serve as a permanent form and/or positive reinforcement for concrete floor slabs. Members of SDI are manufacturers of steel floor and roof decks. Associate members are manufacturers of fasteners, coatings, and other related components.

**Steel Erectors Association of America (SEAA)**

2216 West Meadowview Road, Ste 115, Greensboro, NC 27407.  
(336) 294-8880  
(413) 208-6936 (fax)  
[www.seaa.net](http://www.seaa.net)

The Steel Erectors Association of America is dedicated to advancing the common interests and needs of all engaged in building with steel. The Association's objectives in achieving this goal include the promotion of safety, education, and training programs for steel erector trades, development and promotion of standards, and cooperation with others in activities which impact the commercial construction business.

**Steel Joist Institute (SJI)**

3127 10th Ave., North Ext., Myrtle Beach, SC 29577  
(843) 626-1995  
(843) 626-5565 (fax)  
[www.steeljoist.com](http://www.steeljoist.com)

The Steel Joist Institute (SJI) is a not-for-profit organization. Besides setting standards for the steel joist industry, SJI works closely with major building code bodies throughout the country helping to develop code regulations regarding steel joists and joist girders. SJI also invests thousands of dollars in ongoing research related to steel joists and joist girders, and offers a complete library of publications and other training and research aids.

**Steel Plate Fabricators Association (SPFA)**

11305 Reed Hartman Highway, Suite 202, Cincinnati, Ohio, 45241  
(513) 469-0500  
(513) 469-0599 (fax)  
[www.spfa.org](http://www.spfa.org)

The Steel Plate Fabricators Association (SPFA) has been a forum for the steel plate fabricating industry for nearly 60 years. Members are fabricators manufacturing products from steel plate and companies supplying goods and technology. SPFA promotes profitable industry growth through award programs for the Steel Plate Fabricated Product of the Year for reservoir, elevated, and standpipe storage tanks, quality certification for steel pipe and accessory manufacturers, seminars on steel water pipe, steel water tanks, welding cost reduction, and productivity. Services include a monthly business trends report.

**Steel Recycling Institute (SRI)**

680 Anderson Dr., Pittsburgh, PA 15220-2700  
(412) 922-2772 or (800) 876-7274  
[www.recycle-steel.org](http://www.recycle-steel.org)

The Steel Recycling Institute (SRI), a unit of the American Iron and Steel Institute, is an industry association that promotes and sustains the recycling of all steel products. The SRI educates the solid waste industry, government, business and ultimately the consumer about the benefits of steel's infinite recycling cycle.

**Steel Tank Institute (STI)**

570 Oakwood Road, Lake Zurich, IL 60047  
(847) 438-8265  
(847) 438-8766 (fax)  
[www.steeltank.org](http://www.steeltank.org)

The Steel Tank Institute (STI) is a trade association and standards-setting body representing steel tank fabricators and affiliated corporations. STI develops technical standards for fabrication, corrosion control, installation, and





secondary containment of underground and aboveground storage tanks. STI members manufacture single- and double-wall steel UST's with sti-P3 or ACT-100R corrosion protection systems, new Permatank™ double-wall UST's and F911™ and F921™ secondarily contained aboveground tanks.

**Steel Tube Institute of North America (STI)**

8500 Station Street, Suite 270, Mentor, OH 44060  
(440) 974-6990  
(440) 974-6994 (fax)  
[www.steeltubeinstitute.org](http://www.steeltubeinstitute.org)

The Steel Tube Institute of North America (STI), founded in 1930, promotes the responsible growth, prosperity, and competitiveness of the steel tubing industry. STI collects and disseminates information on manufacturing techniques and data and analysis on growth areas, market trends, and product applications. STI provides information to customers on tubular products. Active members are producers of mechanical, pressure, and structural tubing. Associates are suppliers of raw materials and equipment to the tubular products industry.

**Structural Stability Research Council (SSRC)**

University of Florida, Dept. of Civil and Coastal Engineering, 345 weil Hall, P.O. Box 116580  
Gainesville, FL 32611-6580  
(352) 846-3874 ext. 1424  
(352) 846-3978 (fax)  
[www.ce.ufl.edu/~ssrc](http://www.ce.ufl.edu/~ssrc)

The Structural Stability Research Council (SSRC), founded in 1944, offers guidance, through its 16 task groups and 8 task reporters, to specification writers and practicing engineers by developing both simplified and refined calculation procedures for the solution of stability problems, and assessing the limitations of these procedures. SSRC holds regular annual meetings to report on research activities and to indicate where deficiencies exist in our present understanding of structural behavior. The membership of the SSRC is made up of representatives from organizations, consulting firms, and individuals.

**Underwriters Laboratories Inc. (UL)**

333 Pfingsten Road, Northbrook, IL 60062-2096  
(847) 272-8800  
(847) 272-8129 (fax)  
[www.ul.com](http://www.ul.com)

Underwriters Laboratories Inc. (UL), an independent, not-for-profit, safety testing and certification organization, evaluates products, materials, and systems in the interest of public safety. Founded in 1894, UL is neither a commercial enterprise nor a government agency, but a member of the private sector whose primary objective is to help manufacturers bring safer products to U.S. and global markets. More than 6 billion UL Marks are placed on products annually by more than 40,000 manufacturers. A UL Listing Mark on a product means samples of the product have been tested to nationally recognized safety standards and have been found to be reasonably free from fire, electric shock, and related safety hazards.

**Welding Research Council (WRC)**

3 Park Ave. 27th Floor, New York, NY 10016-5902  
(212) 591-7956  
(212) 591-7183  
[www.forengineers.org/wrc](http://www.forengineers.org/wrc)



## FEDERAL AND STATE GOVERNMENT AND RELATED AGENCIES

### **Army Corps of Engineers**

Office of the Chief of Engineers, Hdqr., U.S. Army corps of engineers, 1000 Independence Avenue SW, Washington, DC 20314-1000  
(202) 761-0660  
(202) 272-1803 (fax)  
[www.usace.army.mil/](http://www.usace.army.mil/)

### **American Association of State Highway and Transportation Officials (AASHTO)**

444 N. Capitol Street, N.W., Suite 249, Washington, DC 20001  
(202) 624-5800  
(202) 624-5806 (fax)  
[www.aashto.org](http://www.aashto.org)

### **Bureau of Labor Statistics**

Postal Square Building, 2 Massachusetts Ave. NE, Washington, DC 20212-0001  
(202) 606-7828  
<http://stats.bls.gov/>

### **Department of Housing and Urban Development (HUD)**

451 Seventh Street, S.W., Washington, DC 20410  
(202) 708-1112  
(202) 708-0299 (fax)  
[www.hud.gov](http://www.hud.gov)

### **Environmental Protection Agency (EPA)**

1200 Pennsylvania Ave. NW, Washington, DC 20460  
(202) 382-2090  
[www.epa.gov](http://www.epa.gov)

### **Federal Construction Council (FCC)**

c/o National Academy of Sciences, 2101 Constitution Avenue NW, Washington, DC 20418  
(202) 334-3378

### **Federal Highway Administration (FHA)**

Department of Transportation, 400 Seventh Street, S.W., Washington, DC 20590  
(202) 366-0650  
(202) 366-3244  
[www.fhwa.dot.gov](http://www.fhwa.dot.gov)

### **Federal Railroad Administration**

1120 Vermont Ave. NW., Washington, DC 20590  
(202) 493-6130  
(202) 493-6171  
[www.fra.dot.gov/site](http://www.fra.dot.gov/site)

### **General Services Administration (GSA)**

[www.gsa.gov](http://www.gsa.gov)

**National Institute of Building Sciences (NIBS)**

1090 Vermont Ave., N.W., Suite 700, Washington, DC 20005  
(202) 289-7800  
(202) 289-1092 (fax)  
[www.nibs.org](http://www.nibs.org)

**National Institute of Standards and Technology (NIST)**

NIST, 100 Bureau Drive, Stop 3460, Gaithersburg, MD 20899-3460  
(301) 975-6478  
(301) 975-8295 (fax)  
[www.nist.gov](http://www.nist.gov)

**National Science Foundation (NSF)**

4201 Wilson Boulevard, Arlington, Virginia 22230  
(703) 292-5111  
(703) 292-5090  
[www.nsf.gov](http://www.nsf.gov)

**National Technical Information Service (NTIS)**

NTIS Operations Center, 5285 Port Royal Road, Springfield, VA 22161  
(703) 605-6000  
(703) 321-8547 (fax)  
[www.ntis.gov](http://www.ntis.gov)

**Occupational Safety and Health Administration (OSHA)**

Department of Labor, 200 Constitution Avenue, N.W., Washington, DC 20210  
(202) 693-1999  
[www.osha.gov](http://www.osha.gov)

**FOREIGN ORGANIZATIONS****Australian Institute of Steel Construction (AISC)**

Level 13, 99 Mount Street, North Sydney, Australia NSW 2060  
PO Box 6366, North Sydney, Australia NSW 2059  
011-61-2/9296666  
011-61-2/9555406 (fax)  
[www.aisc.com.au](http://www.aisc.com.au)

**British Constructional Steelwork Association (BCSA)**

4 Whitehall Court  
London, SW1A 2ES, United Kingdom  
011-4471-839-8566  
011-4471-976-1634 (fax)  
[www.metalworld.com/assn/aa008150.html](http://www.metalworld.com/assn/aa008150.html)

**Canadian Institute of Steel Construction (CISC)**

201 Consumers Road, Suite 300, Willowdale, Ontario, Canada M2J 4G8  
(416) 491-4552  
(416) 491-6461 (fax)  
[www.cisc-icca.ca/](http://www.cisc-icca.ca/)



The Canadian Institute of Steel Construction (CISC), a national association, represents the structural steel, steel platework, and open-web steel joist industries by promoting good design, safety, and efficient and economical use of steel as a means of expanding markets for its Fabricator, Mill, Honorary, and Associate Members. Services encompass steel design information, technical publications, such as the Handbook of Steel Construction, computer programs, continuing education courses, marketing, and industry-government relations. CISC manages the Steel Structures Education Foundation and the Canadian Steel Construction Council.

**Canadian Sheet Steel Building Institute (CSSBI)**

652 Bishop St. N., Unit 2A Cambridge, Ontario N3H 4V6  
(519) 650-1285  
(519) 650-8081 (fax)  
[www.cssbi.ca](http://www.cssbi.ca)

The Canadian Sheet Steel Building Institute, commonly called the CSSBI, is the national association of companies involved in the structural sheet steel industry. To find out more on who we are and what we do, navigate the buttons in the left sidebar.

**European Convention for Constructional Steelwork (ECCS)**

Avenue des Ombrages, 32/36 boîte 20, B1200, Brussels, Belgium  
011-322-762-0429  
011-322-762-0935 (fax)  
[www.steelconstruct.com](http://www.steelconstruct.com)

**Japanese Society of Steel Construction (JSSC)**

848 Shin Tokyo Building, 3-3-1 Marunouchi Chiyoda-Ku, J-Tokyo 100  
011-81-3/32120875  
011-81-3/32120878 (fax)  
[www.jssc.or.jp](http://www.jssc.or.jp)

**Mexican Institute of Steel Construction (MISC)**

Amores 388, Col. del Valle, Mexico, DF  
011-525-565-6800  
011-525-390-1416 (fax)

**South African Institute of Steel Construction (SAISC)**

7th Floor, Metal Industries House, 42 Anderson Street, Johannesburg, South Africa 2001  
PO Box 1338, Johannesburg, South Africa 2000  
011-27-22-838-1665  
011-27-11-834-4301 (fax)  
[www.saisc.co.za/](http://www.saisc.co.za/)

# INDEX

## A

Accelerated cooling, A10  
 Acceleration ratio, S20, S22-24  
 Acrylics, S30  
 Additives, S26-29, S53  
 Adhesion testing of coating, S47  
 AESS (see Architecturally exposed structural steel)  
 AISC Quality Certification, A3, A28, A104, A105  
 Alkyds, S30, S32, S46, S49  
 Anchors, D6-8, D14, D15  
 Angles (L-Shapes), M3-5  
     Dimensions, M23-26  
     Shape and box perimeters, M57-60  
 Architecturally exposed structural steel, A112-115, S72, S73  
 ASTM A6/A6M, A3-5, A13-14, A16, A36, A64-65  
 ASTM E119 test method, S57, S60, S61, S71, S76

## B

Back-up systems, D14  
 Bars, M6-7  
 Beam web penetrations, D17, S15, S16  
 Bearing piles (HP-Shapes), M4  
     Dimensions, M18  
     Shape and box perimeters, M54  
 Bending and shaping structural members, A12, S97, S99  
 Binders (see Non-volatile vehicles)  
 Bolt holes, A8, A10, A11  
     Long-slotted holes, A12, A17  
     Short-slotted holes, A17  
 Braced frames, S11-14  
 Bracing members, D3, D19  
 Brick, D5, D6  
 Blast cleaning  
     Brush off (SSPC-SP7), S40  
     Commercial (SSPC-SP6), S40, S42  
     Near-white metal (SSPC-SP10), S40, S42, S43  
     White metal (SSPC-SP5), S40

## C

Cantilevered members, D10  
 Certified Mill Test Report (CMTR), A3, A5-7  
 Channels, M4  
     American standard (C-Shapes)  
         Dimensions, M21  
         Shape and box perimeters, M55  
     Miscellaneous (MC-Shapes)  
         Dimensions, M22  
         Shape and box perimeters, M56  
 Chevron bracing, S13  
 Coating evaluation, S50  
     Quality assurance, S49  
 Coating systems, S21, S31, S36, S42, S44, S45, S48, S50, S53  
 Coating test methods, procedures, S46-48, S51, S53  
 Code of Standard Practice, A8, A12-17, A19, A20, A25-116  
 Coefficient of linear expansion and contraction, S17  
 Cohesion testing of coating, S47  
 Cold bending (see Bending and shaping structural members)  
 Compatibility of overcoating system, S48  
 Composite steel floor deck, D3  
 Composition of coatings, S26  
 Concrete masonry unit (CMU), D5, D6, D14, D15  
 Contraction, S17  
 Contracts, A107-111  
 Corrosion process, S25, S26  
 Corrosive environments, S33-34, S36, S38, S51-54  
 Critical damping, S20, S21  
 Cross bracing, S12  
 C-Shapes (see Channels)  
 Cutting steel, A7-8  
 Cyclically loaded structures, A4, A10, A13

## D

Damping, vibration control, S20-S24  
 Dead loads, S9, S77, S78, S89  
 Diagonal bracing, detailing, D18-19

Diaphragm, S11, S15  
Double-column movement connection, S19  
Drilling, A9, A10, A108  
Dry film thickness testing, S46, S48  
Dynamic loading, S20, S21

## E

Eccentrically braced frames, S13  
Edge discontinuities, A4  
Enclosure system, D3, D5, D6, D9, D16  
Epoxy, S27, S29, S32  
Erection, A79-103  
Expansion, S17, S18, S42, S67, S71, S72, S73  
Expansion joint, S17, S18  
Exposed welded connections, S99

## F

Fabrication and delivery, A68-78  
Fillet welds, S44, S99, S100  
Finishing steel, A7-9

- Face machining, A8
- Grinding, A8, A9, A11, A12, A20, A101, A114
- Milling, A8, A69, A108
- Planing, A8, A108

Fire protection, S57-74

- Architecturally exposed steel (exterior), S72
- Architecturally exposed steel (interior), S73
- Building codes, S57
- Combustibility of structural materials, S58
- Effect of temperature on steel, S60
- Fire resistance of structure, S58
- General factors, S57
- Rational fire design, S74
- Restrained and unrestrained construction, S65
- Temperatures of fire exposed structural steel, S60
- Weight-to-heated perimeter ratio, S60-62

Fire protection materials, S62-65

- Concrete and masonry, S64
- Gypsum, S62
- Intumescent coating, S65
- Spray-applied materials, S63
- Suspended ceiling systems, S64
- Fireproofing, D4, D6, S59
- Firestopping, D10-12, D14-16
- Flame cutting, A6, A8, A10, A11
- Flexible diaphragm, S11
- Floor panel, S22
- Floor structures
  - Resonance, S20, S21
  - Stiffness, S20, S72
- Floor system, D3, D4
- Floor vibration, S20-24
- Floor/ceiling sandwich, detailing, D17
- Free vibration, S21
- Frequency, S21-24
- Full penetration weld, S15, S100

## G

- Galvanized steel-painted (duplex system), S32
- Gravity load, D9, S9, S13, S14, S89
- Groove welds, S99, S100

## H

- Hand tool cleaning (SSPC-SP2), S40, S45, S46, S49
- Harmonic multiple, S20, S21, S23
- Heat straightening, A10
- Hole sawing, A10
- Hollow structural sections (HSS), A3, A5, M5-6
  - Round HSS
    - Dimensions, M36-39
    - Shape and box perimeters, M83-86
  - Rectangular and square HSS
    - Dimensions, M27-35
    - Shape and box perimeters, M71-82
- Hot-dip galvanizing, S31, S32



HP-Shapes (see Bearing piles)  
HSS (see Hollow structural sections)

## I

Inside corners, detailing, D9  
Intumescent paints, S31, S65

## L

Lateral load, S10-15, D9  
Lateral resistance, S11, S79, S80, S89  
Lateral systems, D3, D9, D18, S11-15  
Limestone panels, detailing, D14  
Live loads, S9, S20, S23, S77, S89  
Load flow, S9  
Longitudinal stiffeners, A14, A15  
L-Shapes (see Angles)

## M

Masonry, detailing, D5-8  
MC-Shapes (see Channels)  
Metal deck, D3, D4  
Metal stud back-up system, D5  
Metric design equivalent, A5  
Modal analysis, S22  
M-Shapes  
    Dimensions, M19  
    Shape and box perimeters, M52

## N

Natural frequency (see Frequency)  
Non-composite steel floor deck, D3  
Non-volatile vehicles, S26, S27

## O

Overcoat paint process, S38, S42, S46, S48, S49  
Oversized holes, A17

**P**

Paint system guides (see insert after S56)  
Paint systems, S25, S32, S36, S37, S38, S48, S52  
Painting  
    Blast profile limits, A20  
    Contract documents, A18-21  
    Determining film thickness, A18-20  
    Economics, S54-55  
    Edge preparation, A8, A20  
    Film thickness inspections, A19  
    Shop coat, A18, A73-75, S39, S42, S44,  
    Welded surfaces, A21  
Peak acceleration for human comfort, S23  
Pickling (SSPC-SP8), S40  
Pigments, S26, S27, S46  
Pipe, M6  
    Dimensions, M40  
    Shape and box perimeters, M87  
Plans and specifications, A49-57  
Plates, M6-7  
Polyurethane, S27-30, S53  
Power tool cleaning (SSPC-SP3), S40, S41, S43, S44, S46, S48  
Power tool cleaning (SSPC-SP11), S40, S41, S44, S46, S48  
Precast concrete, detailing, D9-13  
Preparing bare metals, S42-46

**R**

Re-entrant corners, A9  
Reaming, A10, A12, A101  
Record retention, A7  
Repairing notches or gouges, A9, A11  
Resonance, S20, S21  
Rigid diaphragm, S11  
Rigid frames, S11, S14, S15

**S**

Seal weld, S100

Seismic activity, S9-13

Shear walls, S11, S15, D3

Shop and erection drawings, A58-63

Sizing

    Girders and beams, S77-88

    Interior columns, S89-96

Slide bearing connection, S18, S19

Society for Protective Coatings, A133, S39-49, S52

Solvent cleaning (SSPC-SP1), S40, S41, S45, S48, S49

Solvents (see Volatile vehicles)

Span ranges of structural steel, S77, S78, S88

Spandrel, D9, D10

Special purpose coatings, S31, S32

Spectrum, S22

Spray-applied fire protection, S25, S35, S63-65

S-Shapes

    Dimensions, M20

    Shape and box perimeters, M53

Steady state motion, S21

Step frequency, S21

Stiffener plates, D10

Structural tees, M5

    Cut from M-Shapes

        Dimensions, M44

        Shape and box perimeters, M69

    Cut from S-Shapes

        Dimensions, M44

        Shape and box perimeters, M70

    Cut from W-Shapes

        Dimensions, M41-43

        Shape and box perimeters, M61-68

Structural tubing (see Hollow structural sections)

Sub-punching, A10  
Substrate examination and evaluation, S50, S51, S53  
Supports, D3, D5, D9, D14  
Surface condition, A3, A4, A9, A18  
Surface preparation, S32, S39-42, S44-46, S48-50, S55

## T

Tees (see Structural tees)  
Tension-only members, S12  
Thermal movement of structural steel, S17, S18  
Thin stone veneer, detailing, D15  
Tolerances, A16

- Construction, D9
- Erection, A13-18, A21
- Fabrication, A13, A14, A16
- Mill, A3, A13, A65

Torsional forces, D9, D10  
Traceability, A6, A7  
Transient motion, S9, S20, S21  
Tubes (see Hollow structural sections)

## U

Underwriters Laboratories, D4, A135

## V

Vertical loads, S9, S11

Vibration (see Floor vibration)

Volatile vehicles (solvents), S26

## W

Web penetrations (see Beam web penetrations)

Welding symbols, S99, S100, S102-103

Wind forces, S10, S11, D9, D14, D16

Window wall, detailing, D16

Work lines, D18

Work point, D19

W-Shapes, M3-4

    Dimensions, M11-17

    Shape and box perimeters, M45-51

## Z

Zinc-rich primers, S29

