

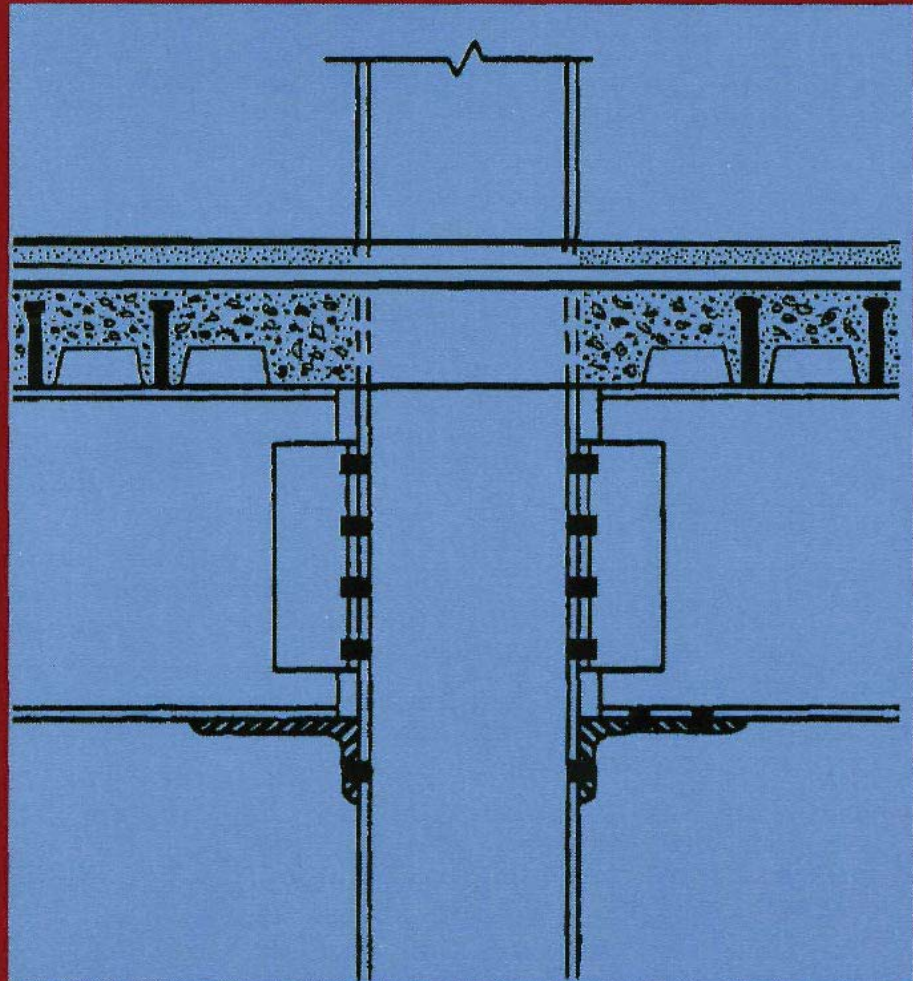

# 8

*Steel Design Guide Series*

# *Partially Restrained Composite Connections*





***Steel Design Guide Series***

# ***Partially Restrained Composite Connections***

## **A Design Guide**

Roberto T. Leon  
Georgia Institute of Technology  
Atlanta, Georgia

Jerod J. Hoffman  
Meyer, Borgman and Johnson, Inc.  
Minneapolis, Minnesota

Tony Staeger, RE.  
Hammel Green & Abrahamson, Inc.  
Minneapolis, Minnesota

Copyright © 1996

by

American Institute of Steel Construction, Inc.

*All rights reserved. This book or any part thereof  
must not be reproduced in any form without the  
written permission of the publisher.*

The information presented in this publication has been prepared in accordance with recognized engineering principles and is for general information only. While it is believed to be accurate, this information should not be used or relied upon for any specific application without competent professional examination and verification of its accuracy, suitability, and applicability by a licensed professional engineer, designer, or architect. The publication of the material contained herein is not intended as a representation or warranty on the part of the American Institute of Steel Construction or of any other person named herein, that this information is suitable for any general or particular use or of freedom from infringement of any patent or patents. Anyone making use of this information assumes all liability arising from such use.

Caution must be exercised when relying upon other specifications and codes developed by other bodies and incorporated by reference herein since such material may be modified or amended from time to time subsequent to the printing of this edition. The Institute bears no responsibility for such material other than to refer to it and incorporate it by reference at the time of the initial publication of this edition.

Printed in the United States of America

Second Printing: October 2003

# TABLE OF CONTENTS

<b>PART I: BACKGROUND</b> .....	<b>1</b>
1. Introduction .....	1
2. Characterization of Connection Behavior.....	1
3. Advantages and Limitations .....	3
4. Connection $M-\theta$ Curves .....	3
5. Analysis.....	5
5.1 Service Load Range .....	5
5.2 Beam Line Analysis for Gravity Loading at Service .....	5
5.3 Connection Ultimate Strength (Gravity Loads) .....	6
5.4 Frame and Beam Ultimate Strength.....	7
6. Design Considerations.....	8
6.1 PR Beam Deflections .....	8
6.2 Lateral Drift .....	9
6.3 Beam Stiffness .....	9
6.4 PR-CC Effect on Column End Restraint.....	10
6.5 Bottom Angle Connection .....	10
7. Detailing .....	11
8. References.....	12
<b>PART II DESIGN PROCEDURES</b> .....	<b>15</b>
1. Introduction .....	15
2. PR-CCs for Gravity Design in Braced Frames ....	15
2.1 Introduction.....	15
2.2 Recommended Design Procedure— Braced Frames .....	16
3. PR-CCs for Lateral Resistance in Unbraced Frames.....	18
3.1 Introduction.....	18
3.2 Design Procedure for Unbraced Frames .....	18

<b>PART III: DESIGN EXAMPLE</b> .....	<b>21</b>
PR-CCs in Braced Frames: N-S Direction.....	23
PR-CCs in Unbraced Frames: E-W Direction .....	27

<b>PART IV: TABLES AND DESIGN AIDS</b> .....	<b>37</b>
Table 1—Prequalified PR-CCs for unbraced frames..	37
Table 2— $M1$ and $M2$ values for PR-CCs.....	40
Table 3—Beam line and deflection coefficients for common loading patterns .....	44
Table 4—Collapse mechanism coefficients for beams	45
Table 5— $S_p$ values .....	46
Table 6— $C_\theta$ values .....	46
Table 7—Negative bending moments of inertia.....	47
Table 8—Details of prequalified connections .....	53

<b>APPENDIX A</b> .....	<b>57</b>
-------------------------	-----------

<b>NOTATION</b> .....	<b>59</b>
-----------------------	-----------

## List of Figures

Figure 1—Partially restrained composite connection ..	1
Figure 2—Characterization of connection behavior ...	2
Figure 3—Complete $M-\theta$ curves for a typical PR-CC..	4
Figure 4—Beam line analysis.....	6
Figure 5—Plastic collapse mechanism.....	7
Figure 6—Components of PR frame drift .....	9
Figure 7—Detailing requirements .....	11
Figure 8—Detailing requirements .....	11

# Preface

This booklet was prepared under the direction of the Committee on Research of the American Institute of Steel Construction, Inc. as part of a series of publications on special topics related to fabricated structural steel. Its purpose is to serve as a supplemental reference to the *AISC Manual of Steel Construction* to assist practicing engineers engaged in building design.

This document is intended to provide guidelines for the design of braced and unbraced frames with partially restrained composite connections (PR-CCs). The design procedures and examples in this guide represent a refinement of the work presented by Ammerman and Leon<sup>7,8</sup> and is thoroughly documented in more recent work by the authors.<sup>12,21</sup> The design of structures utilizing PR-CCs for gravity and wind loads falls under the provisions of Section A2.2 of the LRFD Specification for Structural Design of Buildings. Design for seismic loads is allowed under Section 7.4.1 of the latest version of the NEHRP provisions.

The guide is divided into four parts. The first part is an introduction dealing with topics pertinent to partially restrained (PR) analysis and design, and discusses some of the important design choices utilized in the design procedures and examples. The second part contains detailed, concise design procedures for both braced and unbraced frames with partially restrained composite connections. The third part consists of a detailed design example for a four-story building. The design is for an unbraced frame in one principal direction and for a braced frame in the other. The fourth part contains design aids in the form of Tables and Appendices.

It is important that the reader recognize that the guide is intended to be a self-contained document and thus is longer than comparable documents dealing with similar topics. The reader is advised, on a first reading, to read Parts I and III carefully, consulting Part IV as necessary. Once the reader is familiar with the topic, he/she will only need to consult Parts II and IV in doing routine design work.

The design guidelines suggested by the authors that are outside the scope of the AISC Specification or Code do not represent an official position of the Institute and are not intended to exclude other design methods and procedures. It is recognized that the design of structures is within the scope of expertise of a competent licensed structural engineer, architect, or other licensed professional for the application of principles to a particular structure.

## Acknowledgments

The authors would like to thank the following people who have been very helpful in the writing of this design guide and have also been key players in its development: Heinz Pak, former Manager of Building Engineering for AISC, initiated and sponsored the guide; Larry Kloiber of LeJeune Steel provided input particularly in the practical fabrication aspects of the connection; Dave Galey, Zina Dvoskin, and Johanna Harris of HGA's Structural Engineering Department who helped developed the first draft of this guide and provided invaluable input and assistance throughout the project; Bob Lorenz, Director of Education and Training, and Nestor Iwankiw, Vice President of Technology and Research for AISC, whose patience and support made this document possible.

*The information presented in this publication has been prepared in accordance with recognized engineering principles and is for general information only. While it is believed to be accurate, this information should not be used or relied upon for any specific application without competent professional examination and verification of its accuracy, suitability, and applicability by a licensed professional engineer, designer, or architect. The publication of the material contained herein is not intended as a representation or warranty on the part of the American Institute of Steel Construction, Inc. or the American Iron and Steel Institute, or of any other person named herein, that this information is suitable for any general or particular use or of freedom infringement of any patent or patents. Anyone making use of this information assumes all liability arising from such use.*

# Part I BACKGROUND

## 1. INTRODUCTION

Partially restrained connections, referred to as PR connections in the LRFD provisions<sup>1</sup> and Type 3 connections in the ASD provisions,<sup>2</sup> have been permitted by the AISC Specifications since 1949. With some notable exceptions, however, this type of connection has not received widespread application in practice due both to (a) the perceived complexity of analysis required, and (b) the lack of reliable information on the moment-rotation characteristics of the connections as required by design specifications. The notable exceptions involve specific types of connections that have been demonstrated, through experience in the field and extensive analytical work,<sup>3,4</sup> to provide equivalent response under design conditions to that of rigid connections. The Type 2 or "wind" connections allowed under the ASD provisions are a good example of this approach. In these cases the specification essentially prequalifies a simple connection under gravity loads as a rigid connection under lateral loads. In reality, of course, these connections are neither fully rigid (FR) nor simple but partially restrained (PR). The code uses this artifice to simplify the analysis and design, but requires a guaranteed rotational and strength capacity from these connections.

After 10 years of research and development a new type of semi-rigid connection, labelled the Partially Restrained Composite Connection or PR-CC,\* can be added to this list.<sup>5-12</sup> The word "composite" is used to indicate that this connection engages the reinforcing steel in the concrete slab to form the top portion of the moment resisting mechanism under both live loads and additional dead loads applied after the end of construction (Figure 1). The bottom portion is typically provided by a steel seat angle with web angles providing the shear resistance. This connection may be used to economize beam sizes for gravity loading or to resist lateral loads in unbraced frames. The design of this type of system is based not only on the work of the senior author at the University of Minnesota,<sup>5-12,21</sup> but also on that of many researchers throughout the U.S. and Europe.<sup>11,13-19</sup> The extensive experimental work required in the development of these connections is discussed elsewhere<sup>5,6,9</sup> and will not be repeated here.

Part I of this design guide is organized as follows. First, some discussion of partially restrained connection behavior

will be given to put PR-CC design in its proper context. Second, the advantages and limitations of PR-CCs are discussed in the context of simplified or code-oriented design. Third, the assumptions and theory applied in their design are described. Fourth, detail recommendations for the connections under both gravity and lateral loads are given. In Part II a step-by-step procedure is presented in outline form followed by corresponding detailed calculations for an example problem in Part III. The 1993 *Load and Resistance Factor Design* (LRFD) Specification<sup>1</sup> is used in the design and ASCE 7-93<sup>20</sup> is used for load determination. Tables and design aids are included in Part IV to facilitate the design.

## 2. CHARACTERIZATION OF CONNECTION BEHAVIOR

The behavior of structural connections can be visualized for design purposes with the aid of moment-rotation  $M-\theta$  curves (Figure 2). These curves are generally taken directly from individual tests or derived by best-fit techniques from the results of multiple tests.<sup>22,23</sup> All design specifications require that the structural engineer have a reliable  $M-\theta$  curve for the PR connections to be used in design since such curves syn-

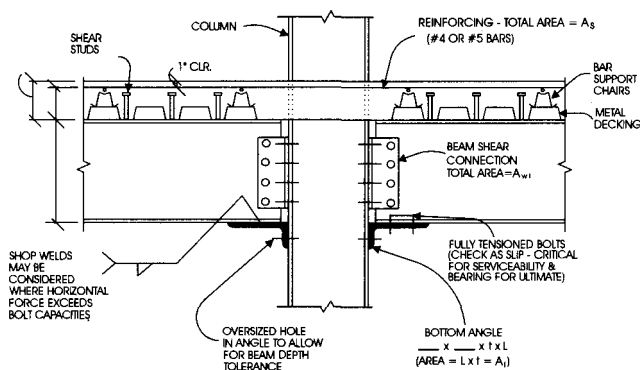

Fig. 1. Partially restrained composite connection (PR-CC).

\* The label PR-CC is meant to encompass the connections previously labelled semi-rigid composite connections (SRCC) by the senior author.

the size the connection's main characteristics: stiffness, strength, and ductility.<sup>6</sup> The application of PR-CCs to design implies that reliable  $M$ - $\theta$  relationships have been developed and are simple enough to use in design. The  $M$ - $\theta$  equations developed for SRCCs will be discussed in detail in Section 4.

In Figure 2(a), the stiffness of the connection corresponds to the slope of the  $M$ - $\theta$  curve. For most connections, such as PR-CCs, the slope changes continuously as the moment increases. The real stiffness of the connection at any stage of the  $M$ - $\theta$  curve corresponds to the tangent stiffness ( $K_{tan} = \Delta M / \Delta \theta$ ). However, for design purposes it is customary to assume a linear approximation for the service range ( $\theta < \theta_{ser}$ ), generally in the form of a secant stiffness ( $K_{conn} = M_{ser} / \theta_{ser}$ ). This stiffness is generally less than the initial stiffness of the connections ( $K_i$ ), and corresponds closely to the unloading stiffness ( $K_{unloading}$ ).

Based on the initial ( $K_i$  or service stiffness ( $K_{conn}$ ), connec-

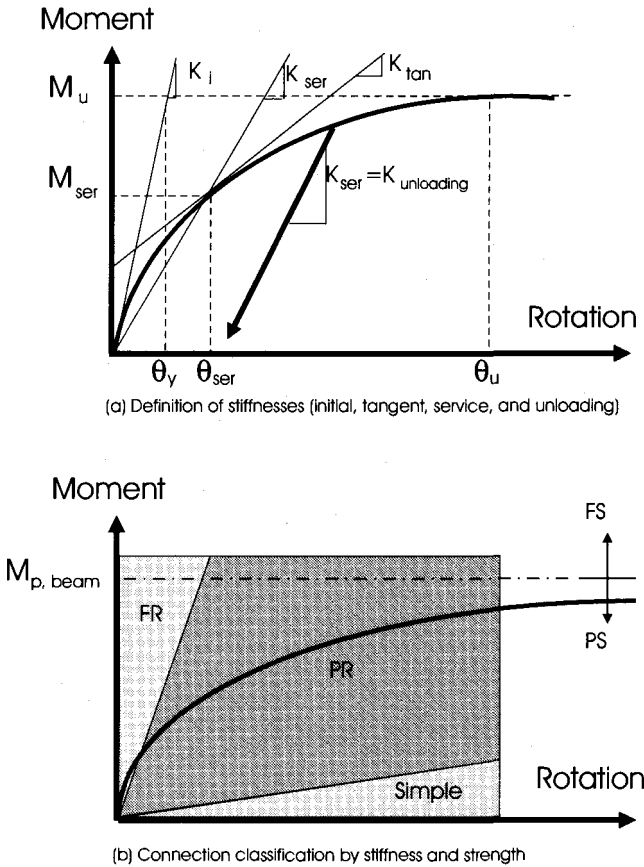

Fig. 2. Characterization of connection behavior.

tions can be classified as fully restrained (FR), partially restrained (PR) or simple depending on the degree of restraint provided (Figure 2(b)). The current approach in design is to assume that for members framing into relatively rigid supports, if the connection stiffness is about 25 times that of the girder (i.e.,  $(K_{conn}L_g / EI_g) > 25$ ), the connection can be considered rigid. Conversely, if the connection provides a stiffness less than 0.5 times that of the girder, then it should be considered simple.\* The classification by stiffness is valid only for the service load range and for connections which do not exhibit significant non-linear behavior at  $M_{ser}$ .

Insofar as strength is concerned, joints can be classified either as full strength (FS) when they are capable of transferring the full moment capacity of the steel beam framing into them or as partial strength (PS) when they are not (Figure 2(b)). The schematic moment-rotation curve for a PR-CC shown in Figure 2(b) does not reach the full  $M_p$  capacity, and thus is a partial strength connection. Partial strength is desirable in seismic design because it permits a calculation of the maximum forces that a structural element will be required to withstand under the uncertain ground motions that serve as an input. If the designer knows what is the maximum moment that a connection can transmit, he/she can insure that other key elements, columns for example, remain elastic and suffer no damage even when the seismic input far exceeds the code prescribed forces. This design philosophy, known as capacity design,<sup>24</sup> is employed in this design guide. Capacity design requires that any hinging region be carefully detailed to dissipate energy and that all other elements in the structure remain basically elastic when the maximum plastic capacity of these regions is reached. Following this design philosophy, the detailing of the PR-CCs is driven by the need to provide a stable, ductile yielding mechanism such as tension yielding of the angle legs rather than a sudden, brittle failure such as bolt shearing.

Ductility is required in structural design so that some moment redistribution can occur before the connection fails. In applications for unbraced frames, and particularly if seismic loads are important, large ductilities are required. Ductilities can be defined in relative terms ( $\theta_u / \theta_y$ , or ultimate rotation capacity divided by a nominal yield one, see Figure 2(a)) or in absolute terms ( $\theta_u > 0.05$  radians, for example). The required ductilities are a function of the structural system being used and whether large cyclic loads need to be considered in the design. In general cyclic ductilities greater than 6 (relative ductility) or 0.035 radians (absolute ductility) are desirable for frames with PR-CCs designed in areas of low to moderate seismic risk. Demands in unbraced frames for areas where wind governs the design or for braced frames are lower.

\* The values of 25 and 0.5 selected here were chosen arbitrarily; ranges from 18 to 25 for the FR limit and 0.2 to 2 for the simple limit are found in the literature. The selection of specific values is beyond the scope of this guide. These values are cited only for illustrative purposes.



The PR-CCs described in this guide meet the criteria for areas of low to moderate seismic risk and can be used for the other design conditions described above.

It is important to recognize at the outset that for design purposes an exact, non-linear moment-rotation curve such as those shown in Figure 2 may not be necessary. In fact, only two important points need to be known for design. The first corresponds to the serviceability level where the stiffness,  $K_{conn}$ , must be known for deflection and drift calculations. The second point is the ultimate strength ( $M_{ult}$ ) and rotation ( $\theta_{ult}$ ) achievable by the connection to insure that adequate plastic redistribution of stresses can occur.

### 3. ADVANTAGES AND LIMITATIONS

There are several practical advantages to PR-CCs. By using reinforcing in the slab the need for a top angle or top plate is eliminated. This provides a more economical solution for several reasons:

- (a) The top force and moment arm are increased resulting in either (1) a reduction of the forces in the connection for a given design moment, or (2) an increase in the connection moment capacity. The difference in strength can be substantial because the ultimate capacity of a seat angle in tension is only about one-third of its capacity in compression (area of its leg times its yield stress). Thus an A 36 1/2-in. top angle 8-in. wide (total force =  $8 \times 0.5 \times 36 \times 0.33 = 48$  kips) can be replaced with four #4 Grade 60 reinforcing bars (total force =  $0.2 \times 4 \times 60 = 48$  kips). The capacity of the connection can then be controlled by the amount of steel in the slab. In addition, in a floor system with shallow beams (say W14s or W16s) the increase in moment arm ( $Y3$ ) can add 20 to 25 percent additional capacity.
- (b) In gravity design PR connections result in an efficient increase of the end moments. For a composite section, the strength in positive bending is typically on the order of 1.8 times that of the steel beam alone ( $M_p$ ). Under a uniformly distributed load, if simple connections are used, the structural efficiency of the system is low because the large capacity of the system is required only at the centerline; most of the section strength is wasted. Similarly, if rigid connections are used the efficiency of the composite system is considerably reduced because the end moments ( $wL^2/12$ ) are large where the section strength is small ( $M_p$ ), and the midspan moments are small ( $wL^2/24$ ) are small where the section strength is large ( $1.8M_p$ ). Only the use of semi-rigid connections and composite action allows the designer to "balance" the connection such that the demand (external moment) is balanced by the supply (section capacity).

- (c) The use of PR-CCs reduces the required beam size and/or reduces deflection and vibration problems because of the composite action provided by the slab. The use of reinforcing bars, as opposed to the common steel mesh used for temperature and shrinkage crack control, is necessary to achieve these benefits. The use of distributed steel reinforcing bars around the columns considerably reduces crack widths over beam and column lines.
- (d) From the construction standpoint the need to cut and resupport the steel decking around the support is eliminated. The placement of some additional reinforcing bars in the slab should not represent significant additional costs.

Connection research on PR frames until recently considered only bending about the strong axis of wide flange columns. In this guide some preliminary recommendations for extending their use to the weak axis of columns in braced frames are given. When used on the weak axis the web angles are typically not used and the connection strength is reduced slightly. In general a stiffened seat is used to help carry the shear force in this situation.

Because of its increased flexibility relative to rigid (Type 1 or FR) connections, the system is most applicable in structures that are ten stories or less, and it should be limited to use with lateral wind forces or seismic loading with ground accelerations less than or equal to 0.2g only, pending further research.

It should also be clear that PR-CCs cannot, in general, be used as substitutes for rigid connections on a one-to-one basis. This implies that more connections will have to participate in resisting the lateral loads in a SRCC frame. The key to the economy of the system is that it allows the designer to turn simple connections into semi-rigid ones by adding only slab steel. The latter is inexpensive and is already being used by many designers to control cracking over column lines. Thus the additional costs for material and labor will be small. The gains in structural efficiency and redundancy will far outweigh the additional construction costs. The recent experience with the Northridge earthquake clearly points out the need for redundancy and ductility in steel lateral load resisting systems. PR-CCs clearly provide a superior level of performance in this respect and can be adopted as a secondary lateral-load resisting system in areas of high seismic risk and as the primary system in areas of low to moderate seismic risk.

### 4. CONNECTION $M-\theta$ CURVES

The most accurate way of modelling the  $M-\theta$  behavior of a semi-rigid connection such as that shown in Figure 2 is through either a continuous exponential or a piecewise linear



function. In advanced computer programs, spring elements with similar  $M-\theta$  characteristics can be input at the ends of the beams to simulate the behavior of the connections. Frames can then be analyzed under a variety of load combinations and the second order effects included directly through the use of a geometric stiffness matrix.

The design procedure proposed here simplifies the analysis to a two-level approach:

- (a) a first order elastic analysis with linear springs at service to check beam deflections and frame drift. These results will be extended to the case of factored loads in order to check the beam-column strength equations.
- (b) a simplified second-order, rigid-plastic analysis with a weak beam-strong column mechanism will be used to check ultimate strength and stability of the frame.

The first level is very similar to what would be used today for a rigid frame design. Many commercially available computer programs incorporate linear springs and thus this type of analysis is well within reach of the average practitioner.

The second level is used here as opposed to the conventional B1 and B2 approach for frame stability because the development of that technique for PR frames, and for frames using PR-CCs in particular, is still underway.<sup>25</sup> Several other alternatives, including (a) a rigorous analysis that models both the non-linearities in the connections and the  $P-\Delta$  effects directly, or (b) an analysis with linear springs, using a secant stiffness to  $\theta_u$ , are possible. The second-order plastic analysis described here is useful for preliminary design. The final design should be checked using advanced analysis tools if the geometry of the frame is not regular with respect to vertical

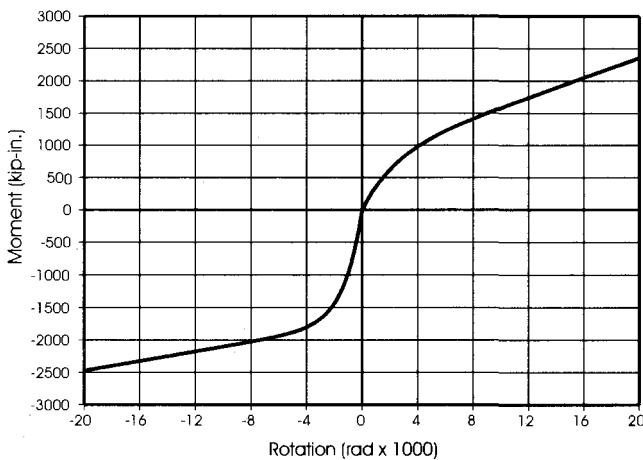

Fig. 3. Complete  $M-\theta$  curve for a typical PR-CC.

and horizontal stiffness distribution. The simplifications required to carry out this two-level approach will be discussed in Section 5.

As noted earlier, specifications require that the engineer have a good idea of the strength and stiffness characteristics of these connections before he/she utilizes them in design. For PR-CCs, the work of Leon et al.<sup>5,26,27</sup> has led to the following expression for the  $M-\theta$  curve under negative bending (slab steel in tension):

$$M_n^- = C1(1 - e^{-C2\theta}) + C3\theta$$

where

$$C1 = 0.18(4 \times A_s F_{yb} + 0.857A_w F_y)(d + Y3)$$

$$C2 = 0.775$$

$$C3 = 0.007(A_i + A_w)F_y (d + Y3)$$

$\theta$  = girder end rotation, radians

$d$  = girder depth, in.

$Y3$  = distance from the top flange of the girder to the centroid of the reinforcement, in.

$A_s$  = steel reinforcing area, in.<sup>2</sup>

$A_i$  = area of bottom angle, in.<sup>2</sup>

$A_w$  = gross area of double web angles for shear calculations, in.<sup>2</sup>

$F_{yb}$  = yield stress of reinforcing, ksi

$F_y$  = yield stress of seat and web angles, ksi

Since the connection behavior is not symmetrical with respect to either strength or stiffness, a similar expression is needed for positive bending (bottom angle in tension):

$$M_n^+ = C1(1 - e^{-C2\theta}) + (C3 + C4)\theta \quad (2)$$

where

$$C1 = 0.2400 \times [(0.48 \times A_w + A_i) \times (d + Y3) \times F_y]$$

$$C2 = 0.02Wx(d + Y3/2)$$

$$C3 = 0.0100 \times (A_w + A_i) \times (d + Y3) \times F_y$$

$$C4 = 0.0065 \times A_w \times (d + Y3) \times F_y$$

These curves were derived from tests and FE parametric studies.<sup>5-6,26-27</sup> The complete curve given by Equations 1 and 2 for a typical PR-CC is shown in Figure 3. This corresponds to a connection of a W18x35 A36 beam with 8 #4 Grade 60 bars in the slab. The bottom angle area is 2.38 in.<sup>2</sup> and the area of the web angles is 4.25 in.<sup>2</sup> The effective depth is 17.7 inches assuming  $Y3$  equal to 4 inches.

Fortunately, experience has shown that PR-CCs in unbraced frames seldom unload into positive moment even under the full factored loads. Thus use of Equation 1 is justified for the service load level and up to the factored loads. Equation 1, however, is still cumbersome for use in design. Given the detailing requirements for capacity design described in Section 7, it is more practical to develop design tables for specific connections. Such tables are shown as Tables 1 and 2, which contain all the necessary design infor-

mation for a series of "prequalified connections."\* In this guide all the connections designed are "prequalified connections" which have been checked for a large number of failure mechanisms and loading conditions.

Table 1 shows some of the key values to be used in design: the ultimate strength of the connection ( $\phi M_n$ ) and the stiffness for checking drift ( $K-lat$ ). Table 1 is divided into two parts, showing values for both angles with 36 ksi and 50 ksi nominal yields. In these tables  $Y3$  is the distance from the top flange of the beam to the centroid of the slab steel. The derivation of the values in Tables 1 and 2 are discussed in the next section, while the detailing is discussed in Section 7.

## 5. ANALYSIS

Once the  $M-\theta$  characteristics are known the next problem is how to analyze frames containing such connections. In this section the analysis and design assumptions used in the design examples (Part III) will be discussed.

### 5.1 Service Load Range

There are several ways to evaluate the performance of beams with PR connections under gravity and lateral loads. They range from using modified slope-deflection or moment distribution equations to using elements with non-linear springs in a computer program that incorporates  $P-\Delta$  effects directly. The following observations are pertinent:

- The latest versions of the better commercial structural analysis packages (stiffness-based methods) allow designers to specify linear springs at the ends of beam elements. Design procedures should strive to use these elements since the availability of multi-linear or fully non-linear (exponential) spring elements in these software packages is not foreseen in the near future.
- While the behavior of the connections is non-linear, the use of a secant stiffness up to about 2.5 milliradians of rotation does not introduce significant error in the force or displacement calculations. Thus the use of linear spring is justified for design of PR-CCs provided the designer keeps in mind that this approach will probably overestimate the forces at the connections but underestimate the deflections.
- Modified slope-deflection, moment distribution, and similar classical approaches, while of great value for those familiar with their implementation, are tedious and prone to errors.<sup>17</sup>
- For those interested in gaining a better insight into connection behavior, a beam-line analysis, described in

detail below, is the preferred method. Note that use of the beam line technique is not advocated for design; it is merely a great educational tool and it is used here in that vein.

In both (a) and (c) above the only unknown is the stiffness to be assigned to the connections. From a simple rigid-plastic analysis where (a) all rotations are lumped at the PR joints and column bases, and (b) a strong column-weak beam mechanism is assumed, it can be shown that the rotation is proportional to the allowable drift. For an allowable drift of  $H/400$ , the corresponding rotation is 0.0025 radian or 2.5 milliradians. Since the deformations of the beams and columns are not included in this calculation, this value overestimates the rotations of the connections. This simplified analysis does not include any  $P-\Delta$  effects which are expected to be negligible at this level even for PR frames. From experience with PR-CCs, it appears that to check service drifts a secant stiffness measured at a rotation of 2 milliradians is sufficiently conservative to avoid too many redesign iterations. The values of the stiffness for drift calculations for the "prequalified connections" are shown in Table 1 as  $K-lat$ . Note that the secant stiffness used is different from the tangent stiffness that would be obtained by differentiating Equation 1 directly and substituting a value of  $\theta = 0.002$  radians.

Following a similar line of reasoning, one could derive conservative values for deflections under gravity loads. Assuming an allowable vertical deflection of  $L/360$ , a value of  $\theta_{ser} = 0.0025$  seems reasonable. Solving Equation 1 for the moment ( $Ml$ ) at the service rotation leads to a similar stiffness for gravity loads ( $K-grav = Ml/0.0025$ ). These moments,  $Ml$ , are tabulated in Table 2, Part IV, for the "prequalified connections". Table 2 is given for different values of  $Y3$  and is divided into connections for braced and unbraced frames because the detailing requirements differ as will be described later. The reader is cautioned not to confuse  $K-lat$ , the connection stiffness for lateral drift, with  $K-grav$ , the connection stiffness for live load deflections. While the difference in the rotations at which they are calibrated is small, this effect has been integrated directly into the design procedure.

### 5.2 Beam Line Analysis for Gravity Loading at Service

The connection must be designed to resist the support moments resulting from gravity loads after the slab has cured and the member is acting as a composite beam. The magnitude of negative gravity moment will always be less than that assuming a fully rigid connection and is dependent on the stiffness of the connection. This can be determined by a beam-line analysis. The three key elements for the beam-line analysis are the moment-rotation relationship of the connection, the

\* The tables are included at end of this guide (Part IV) and are kept separate from the text to facilitate their use in later designs.

simply supported end rotation of the beam, and the fixed end moment assuming a fully rigid connection of the beam. Note that the beam line as defined herein is only applicable in the elastic range.

The moment-rotation relationship for one of the typical connections in Table 1 (W18×35 with 8 #4 bars,  $Y3 = 5$  in.,  $F_y = 36$  ksi) is shown as a solid line in Figure 4. To simplify the beam line analysis the moment-rotation relationship will be reduced to a linear spring. The linear spring is represented in Figure 4 by the dashed line. The corresponding stiffness is given by  $K_{grav} = M1/\theta1 = 147/0.0025 = 58,800$  kip-ft/radian. The values of  $M1$ , again, are tabulated in Table 2.

Two values are needed to define the beam line: the fixed end moment,  $M_F$ , and simply supported end rotation,  $\theta_{ss}$ . These values can be determined by conventional beam analysis methods such as slope deflection, virtual work, or moment area, or can be found in reference tables for most loading patterns. These values have been tabulated for the most common loading patterns in Table 3, Part IV. The fixed end moment depends on whether the connection at the other end is PR or pinned. If the far end restraint is PR then the

fixed-fixed end moment ( $M_{ff}$ ) is used and if it is pinned the fixed-pinned end moment ( $M_{fp}$ ) is used. With the above key elements established, two lines can be drawn, and the intersection of those lines will provide the actual moment and rotation under gravity loading as shown in Figure 4. This intersection point can be solved directly by an equation which results from the solution of simultaneous equations for the two lines in the beam line analysis. The equation of the connection line is:

$$M = K\theta \quad (3)$$

The equation for the beam line is:

$$M = M_F - \left( \frac{M_F}{\theta_{ss}} \right) \theta \quad (4)$$

The value of  $\theta$  at the intersection of these lines is given by:

$$\theta = \frac{M_F}{K_{grav} + \frac{M_F}{\theta_{ss}}} \quad (5)$$

The exact solution, the intersection of the solid line and the beam line, can be obtained by setting Equations 1 and 4 equal to one another and solving for  $\theta$ . This is tedious and generally yields a value very close to that from the linear approximation. Therefore the use of the exact solution is not warranted for preliminary design purposes.

### 5.3 Connection Ultimate Strength (Gravity Loads)

The ultimate capacity of the connection is based on work by Kulkarni.<sup>26</sup> A resistance factor ( $\phi$ ) of 0.85 is recommended and is the same value used for composite beam design in Chapter I of the LRFD Specification.  $M2$  in Figure 4 and Table 2 is the moment which corresponds to a rotation,  $\theta2$ , of 20 milliradians. Most of the connections tested have reached and exceeded this value. Considerable connection yielding and deformation is present at this stage. This moment is included in Figure 4 and the design tables for two reasons. First, it illustrates the ductility of the connections. Second, if the user has software which allows a bi-linear spring to be input for connections,  $M1$  and  $M2$  are useful values which allow a bi-linear curve to approximate the actual curve.

The connection ultimate strength is defined in both the positive and negative directions. The negative bending ultimate strength ( $M_n^-$ ), when the bottom angle is in compression, is:

$$M_n^- = 0.245(4A_s F_{yrb} + A_w F_y)(d + Y3) \quad (6)$$

The positive bending ultimate strength ( $M_n^+$ ) is:

$$M_n^+ = 0.25(1.25A_{wl} + 1.35A_l)(F_y) \left( D + \frac{Y3}{2} \right) \quad (7)$$

The area of the angle,  $A_l$ , is equal to the width of the horizontal

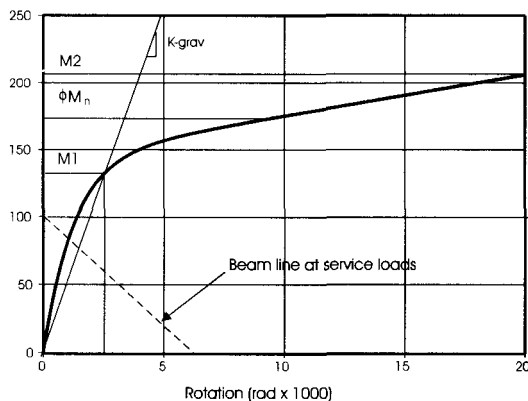
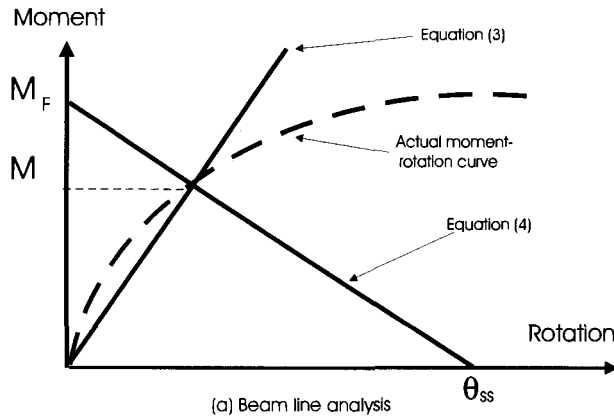

(b) Typical moment-rotation curve for PR-CC and definitions of values in Table 1

Fig. 4. Beam line analysis.

leg times the thickness of the angle leg. The area  $A_{wl}$  is equal to the gross area of the web angles in shear, and  $A_s$  is the total area of steel reinforcing provided in the concrete slab over a width not to exceed seven times the steel column width. The values from Equation 6 evaluated at 10 milliradians and including a  $\phi$  factor of 0.85 are tabulated for the different connections in Table 1 as  $\phi M_n$ . These values have been arbitrarily selected as the design strength for these connections.

The connection can also be used in braced frames without web angles. This would be a simple modification from the current seated beam design useful in designing connections to the weak axis of a column. The bottom angle required for the seated beam would generally be adequate to supply the bottom part of the force couple and a small amount of reinforcement in the slab would provide the top force. The seat angle would need to be thickened or stiffened as needed to take care of the shear force. The ultimate capacity of this connection is:

$$M_n = A_s F_{yb} (d + Y3) \quad (8)$$

Tables 1 and 2, Part IV, provide key information regarding the moment-rotational relationship, ultimate moment capacity, and connection stiffness for a series of typical connection types using steel reinforcement ranging from an area of 1.2 in.<sup>2</sup> to 3.1 in.<sup>2</sup> and beam depths from 12 to 24 inches. The connections selected meet the criteria of explained above plus the detailing requirements discussed in the next section. The force given in the tables is for the design of bolts or welds between the beam bottom flange and angle.

#### 5.4 Frame and Beam Ultimate Strength

Ultimate strength checks will be made for both individual beams and the frame as a whole using plastic analysis.<sup>28-30</sup> The applicable load combinations for ultimate beam capacity from ASCE 7-93 are:

$$1.4D \quad (9)$$

$$1.2D + 1.6L + 0.5(L_r, S, R) \quad (10)$$

$$1.2D' + 1.6(L_r, S, R) + (0.5L, 0.8W) \quad (11)$$

For frame ultimate capacity they are:

$$1.2D + 1.3W + 0.5L + 0.5(L_r, S, R) \quad (12)$$

$$1.2D + 1.0E + 0.5L + 0.2S \quad (13)$$

$$0.9D \pm (1.3W, 1.0E) \quad (14)$$

$$E = \pm 1.0Q_E \pm 0.5A_1 D \quad (15)$$

#### 5.4.1 Beam Ultimate Capacity

The load combination used to calculate the beam load factor is the most critical of combinations given by Equations 9-11.

Commonly the most critical load combination is given by Equation 10. The load factors for beam mechanisms of four different common load cases and for three different connection relationship are shown in Table 4. The general form for these load factors is:

$$\lambda_b = \frac{d}{(P_u \text{ or } w_u L)L} [(aM_{p,c1}) + (bM_{p,c2}) + (cM_{p,b})] \quad (16)$$

where

- $\lambda_b$  = is the load factor,
- $a, b, c,$  and  $d$  = the coefficients given in Table 4, Part IV,
- $M_{p,c1}$  and  $M_{p,c2}$  = are the negative bending ultimate design capacities ( $\phi M_n$ ) of connections 1 and 2, and
- $M_{p,b}$  = is the ultimate moment capacity of the composite beam in positive bending.

#### 5.4.2 Frame Ultimate Capacity

An approximate second order rigid plastic analysis is carried out to determine the overall adequacy of the frame. The controlling combination is generally given by Equations 12 or 13. The collapse mechanism governing this type of design is a weak girder-strong column one (Figure 5).

In plastic analysis two possibilities, proportional and non-proportional loading, arise. Proportional loading, in which both the lateral and gravity loads are increased simultaneously, is commonly used. This design procedure, however, is calibrated to non-proportional loading. In this case the gravity loads are held constant and the lateral loads are increased. Thus, if Equation 12 or 13 is used, the gravity loads ( $D, L, L_r,$  and/or  $S$ ) are kept constant while the lateral loads ( $W$  or  $E$ ) are increased from zero to failure. The multiplier on the lateral loads at failure is the ultimate load factor for the frame,  $\lambda_f$ .

To obtain  $\lambda_f$  the second order effects must be considered.

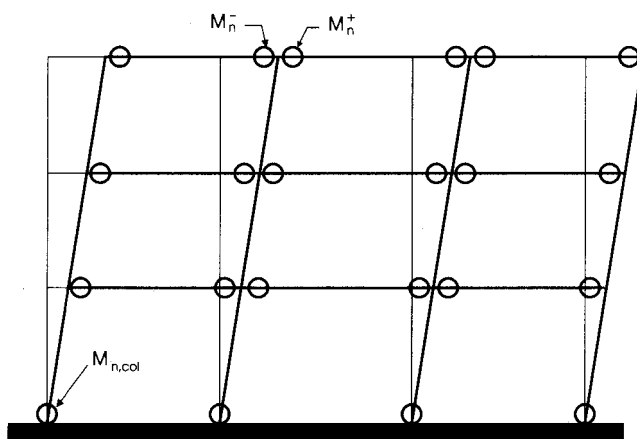

Fig. 5. Plastic collapse mechanism.

Here an approximate method, called the mechanism curve method<sup>28</sup> is used. Before calculating  $\lambda_f$  the first order load factor must be calculated. The first order rigid plastic load factor,  $\lambda_p$ , is calculated as:

$$\lambda_p = \frac{\Sigma \phi M_n}{\Sigma V_i h_i} \quad (17)$$

where  $\phi M_n$  is the moment capacity of a hinge or connection,  $V_i$  is the factored lateral force at story  $i$ , and  $h_i$  is the height from the base to story  $i$ . In this equation the numerator represents the internal resisting forces provided by all hinging regions, while the denominator represents the external loads. Thus any value of  $\lambda_p$  greater than one represents a safe condition. The summation of the connection design strengths are over all the connections, while the summation of  $V_i h_i$  is from 1 to  $S$ , the number of stories.

The calculation of the internal resisting moments requires computing the resistance provided by all elements hinging: the column bases, the external and the internal moments. Symbolically:

$$\Sigma \phi M_n = \Sigma \phi M_{n,col}(R) + \quad (18)$$

$$\Sigma[(N-1)(\phi M_n^+ + \phi M_n^-)_{Inte}] + \Sigma[(\phi M_n^+ + \phi M_n^-)_{Exte}]$$

where

$\Sigma \phi M_{n,col}(R)$  = the summation of the reduced design plastic capacity of the columns at the base of the structure,

$N$  = the number of bays, and

"Inte" and "Exte" refer to the interior and exterior frame connections.

In this equation the summation of positive ( $\phi M_n^+$ ) and negative moment capacities ( $\phi M_n^-$ ) assumes that the connections on either side of each joint have reached their ultimate design capacity. If the exterior connections are simple, then the last term above is zero. To account for the presence of axial load on the plastic capacity of the base columns the following approach is used. If  $P_u < 0.15P_y$  then  $\phi M_{n,col}(R) = \phi M_{n,col}$ , or else:

$$\phi M_{n,col}(R) = 1.18 \left( 1 - \frac{P_u}{P_y} \right) \phi M_{n,col} \quad (18a)$$

where

$P_u$  = the factored load on the column for the lateral load combination, and

$P_y$  = is the axial yield capacity of the column. Now the approximate ultimate load factor including second order effects may be calculated by:

$$\lambda_f = \lambda_p - S_p \lambda_p^2 \left( \frac{\Sigma P \delta}{\Sigma M_n} \right) \quad (19)$$

where

- $P$  = is the story axial load for the frame under analysis,
- $\delta$  = is the interstory drift at 1.0E (or 1.0W),
- $\Sigma M_n$  = is the *nominal* summation of design moment values, and
- $S_p$  = is the sway parameter calibrated for these frames (see table below and Table 5).

Values of $S_p$ for Different Frame Geometries			
No. of Stories	Story Height (ft)		
	12	14	16
4	4.85	4.40	3.10
6	3.70	2.95	2.55
8	2.45	1.95	1.35

The  $S_p$  values above may be interpolated. Note that these values have been calibrated to frames designed with PR-CCs by the present procedure. These values are currently under further evaluation and should not be used with any other frame and connection types.

## 6. DESIGN CONSIDERATIONS

This section explains a number of the design choices made by the authors in selecting, checking and detailing the connections. The topics are separate and are arranged in the order they appear in the design procedure.

### 6.1 Deflections for Beams with PR Connections

The effect of having semi-rigid connections must be included in service deflection checks. The following equation gives the deflection ( $\delta_{SR}$ ) of a symmetrically loaded beam with equal or unequal connection stiffnesses

$$\delta_{SR} = \delta_{FF} + \frac{C_\theta \theta_{sym} L}{4} \quad (20)$$

where

$\delta_{SR}$  = is the deflection of the beam with semi-rigid connections,

$\delta_{FF}$  = is the deflection of the beam with fixed-fixed connections,

$C_\theta$  = is a deflection coefficient, and

$\theta_{sym}$  = is the service load rotation corresponding to a beam with both connections equal to the stiffest connection present.

When the beam has equal connection stiffnesses  $C_\theta$  equals one. When the connection stiffnesses are different  $C_\theta$  may be found in Table 6. The values in Table 6 depend on the ratio of

the less stiff to more stiff connection and on the ratio of the semi-rigid to the fixed-fixed end moment for the stiffer connection. If  $K_a$  is the stiffness of the stiffer connection, the ratio of semi-rigid to fixed-fixed end moment can be expressed as:

$$\frac{M_{SR}}{M_{FF}} = \frac{1}{1 + \alpha}, \quad \alpha = \frac{2EI}{K_a L} \quad (21)$$

where

$M_{FF}$  and  $M_{SR}$  = the fixed-fixed and semi-rigid end moments, respectively.

For design purposes it is beneficial to assume a service rotation for preliminary deflection requirements and then check that deflection after connections have been chosen by either beam line analysis or from:

$$\theta = \frac{M_{FF}}{K_a + \frac{2EI}{L}} \quad (22)$$

Using a 2.5 milliradian service rotation, the connection will add an additional  $L/1600$  to the deflection when the connection stiffnesses are equal. If  $L/360$  is the service limit, this approach now requires that the service load deflection based on a fixed-fixed beam approach be kept below  $L/465$ .

When the beam has one semi-rigid connection and one pinned connection the following equation provides a conservative deflection for any connection stiffness:

$$\delta_{SR} = \delta_{FP} + \frac{\theta L}{5.4} \quad (23)$$

where

$d_{FP}$  = the beam deflection with one end fixed and the other end pinned and

$Q$  = the actual rotation of the semi-rigid connection.

The rotation  $Q$  may be found by a beam line analysis using the fixed-pinned end moment,  $M_{FP}$ .

## 6.2 Lateral Drift

When used in unbraced frames, the flexibility of the connections will cause the lateral deflections of the frame to increase over that which would occur if the connection was fully rigid. To illustrate this effect, the contributions of the columns ( $\Delta_c$ ), beams ( $\Delta_b$ ), and connections ( $\Delta_{conn}$ ) to the total drift ( $\Delta_{total}$ ) can be separated as illustrated in Figure 6.

For preliminary design, the engineer can either estimate the size of the columns based on experience or use a trial-and-error approach combined with a computer program. A hand method to estimate the column sizes, based on the approach given in Figure 6, is included in Appendix A.

In general the design of frames with PR-CCs does not require that the column sizes be increased significantly over those used for an equivalent rigid frame. This is because the

design of frames with PR-CCs takes advantage of the additional stiffness in the beams provided by the composite action (see next section). Thus the additional flexibility due to the PR connections is balanced by a larger beam stiffness and the column sizes need to be increased generally by only one or two sections.

The flexibility of the column base plate connections should be incorporated into these calculations. Drifts in the first floor will probably control the design of many low-rise PR frames. As for unbraced FR frames, the assumption of full fixity at the base should not be made unless careful analysis and detailing of the column base plate justify it.

## 6.3 Beam Stiffness

In modelling PR-CC frame behavior, the effective moment of inertia of the beams ( $I_{eq}$ ) should take into account the non-prismatic nature of the beam, i.e. the variation in moment of inertia for a composite beam with SRCC between areas of positive and negative bending. The moment of inertia in positive areas ( $I_B$ ) can be determined in the traditional way for composite beams and it is recommended that the lower

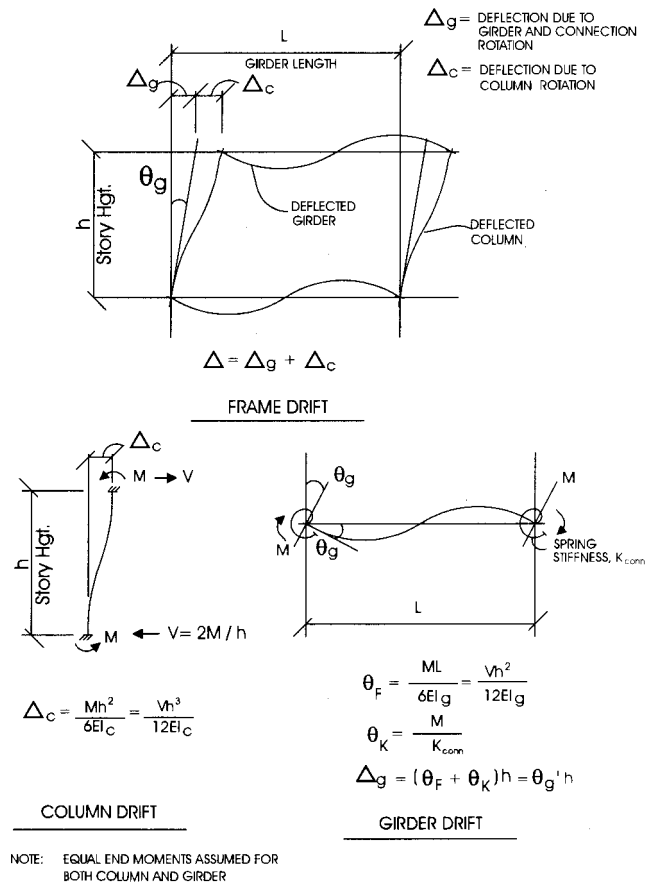

Fig. 6. Components of PR frame drift.

bound tables in the LRFD Manual be used for its determination. The moment of inertia in the negative areas ( $I_n$ ) is a function of the steel beam and the reinforcing in the slab. This can be determined using the parallel axis theory. Table 7 provides values for several combinations of reinforcing and beam sizes for a  $Y3$  (distance from the top flange to centroid of the reinforcing) equal to 3, 4, 5, and 6 inches.

If the positive moment of inertia is denoted as  $I_{LB}$  and the negative moment of inertia is denoted as  $I_n$ , then  $I_{eq}$  is the "prorated" average of the two. For beams with SRCC connections at both ends it is recommended that the following value be used:

$$I_{eq} = 0.6I_{LB} + 0.4I_n \quad (24)$$

When one end has a SRCC and on end pinned:

$$I_{eq} = 0.75I_{LB} + 0.25I_n \quad (25)$$

#### 6.4 PR Connection Effect on Column End Restraint

PR connections reduce the amount of end restraint provided by the beams to the columns when compared to FR connections. This must be considered when carrying out stability checks. The effective moment of inertia of a beam including the effect of the PR connections to be used in calculating  $G$  factors is:<sup>25,31</sup>

$$I_{eff} = I_{eq} \left( \frac{1}{1 + C\alpha} \right) \quad (26)$$

$$\alpha = \frac{2EI_{eq}}{LK_{tan}} \quad (27)$$

where

- $L$  and  $I_{eq}$  = are the beam length and equivalent moment of inertia,
- $K_{tan}$  = is the connection tangent stiffness, and  $C = 1$  for braced frames and  $C = 3$  for unbraced ones.

The main problem in utilizing this formula is that  $K_{tan}$  at the factored load where stability is being checked must be known for each connection. Several simplifications to this approach have been proposed:

- (a) For a frame subjected to lateral loads the connections on one side of the column will continue to rotate in the same direction as the rotations imposed by the gravity loads, while the connection on the other side will rotate in the opposite direction.<sup>25,31</sup> For the connection that continues to load, the stiffness of the connection will decrease and in the limit (i.e. at very large rotations) this stiffness will be zero. The connections on the other side of the column will unload along a path with a stiffness close to the service level stiffness. In calculating  $G$  one can then assume that for one side of the connection the effective beam stiffness ( $I_{eff}$ ) in Equation 26 can be calculated by setting  $K_{tan} = 0$  while for the

other side  $K_{tan} = K_{lar}$ . This results in only one side of the connection, the unloading side, contributing to  $G$ . This procedure is overconservative.

- (b) A similar reasoning for braced frames implies that both connections are loading and that therefore their restraint to the column is negligible. For this case  $K=1$ .
- (c) For unbraced frames, a better, less conservative estimate can be made by assuming that the loading connection has not reached its ultimate capacity. In this case the stiffness of the loading side can be approximated as the slope of a line connecting the service ( $M1, \theta1$ ) and ultimate ( $M2, \theta2$ ) points. The stiffness for the unloading side should still be taken as  $K_{ser}$ .
- (d) Recently it has been suggested that the use of a secant stiffness to the ultimate point ( $M2, \theta2$ ) should also provide a reasonable lower bound to the frame stability. In this case both connections are assumed to have the same stiffness.
- (e) If an advanced analysis is carried out, then the  $K$ -factors can be calculated in the usual manner by using an equivalent stiffness as given by:

$$I_{eff} = I_{eq} \left( \frac{1}{2 \left( 1 + \frac{3}{\alpha/2} \right) - \frac{M_f}{M_n}} \right) \quad (28)$$

where

- $\alpha$  is calculated from Equation 27 using the tangent stiffness, and
- $M_f$  and  $M_n$  are the changes in moment during the last step in the loading at the far and near end of the element, respectively.

For the design example, the stability was checked following the procedure described in (a). A more thorough treatment of this topic, including an example utilizing the same frame as in this design guide, can be found in.<sup>31</sup> In Chapter 3 of this reference, in addition, there is extensive treatment of the extension of the story-based stability procedures to PR frames.

#### 6.5 Bottom Angle Connection

For unbraced frames the bottom angle thickness should be increased so that approximately the same stiffness is provided in the positive direction as the negative direction. To accomplish this the yield force in the bottom angle,  $A_l \times F_y$ , should be at least 1.2 times the force in the reinforcement,  $A_s \times F_{yrb}$ , assuming the angle width remains constant. For braced frames the bottom angle is sized for a force equal to  $A_s F_{yrb}$ .

As shown in Figure 1, the bottom angle is usually connected to the bottom flange of the beam by ASTM A325 or A490 bolts. A 6-in. long angle leg can normally accept 4 bolts (2 rows of 2), but in some cases a 7- or 8-in. leg may be necessary. Bolt bearing and shear must be checked at ultimate



loading assuming some bolt slippage occurs. For service loading, however, it is important that the bolts not slip to ensure that the spring stiffness response is maintained. For this reason, an additional check should be made for service gravity and wind loading against the slip-critical shear values for the bolts, and the bolts should always be fully tensioned. Welding the angle to the bottom flange can also be considered for large forces; in this case the serviceability check need not be performed. Welding of the angle to the column is discouraged since the ductility of the system depends on the ability of the angle to deform plastically as a two member frame.

For each set of reinforcement a set of bottom angles and bolts have been chosen that have passed all the required connection checks by LRFD. These angles and bolts are

shown in Table 8. The force in the bottom angle that was designed for was based on the ultimate capacity design approach. Two of the same type of bolts as for the horizontal leg were used in the vertical leg of the angle for connections to resist tension in unbraced frames. Prying action of the angle was considered. If any other angle and bolt set is used all connection checks must be carried out.

### 7. DETAILING

For SRCCs, the authors and their co-workers have developed the following recommendations (Figures 7 and 8):

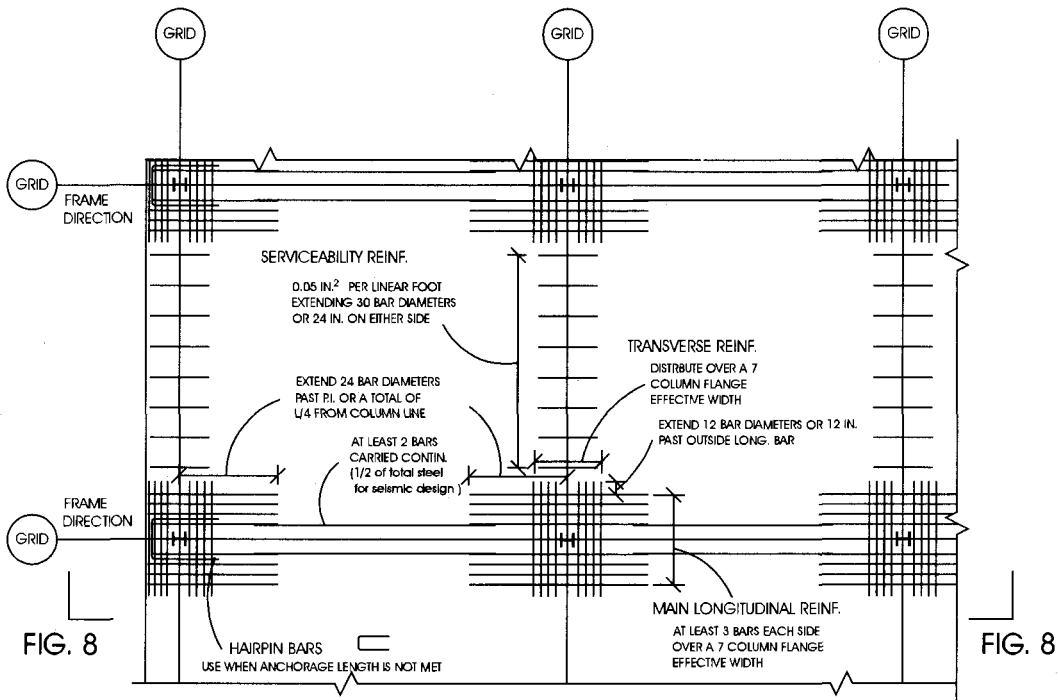

Fig. 7. Detailing requirements (plan view).

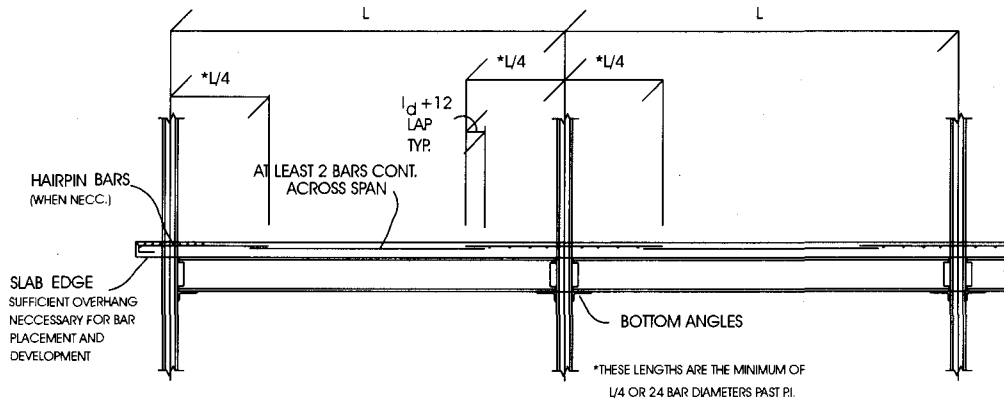

Fig. 8. Detailing requirements (elevation).

- (1) For designs where seismic forces control and a weak beam-strong column mechanism is desirable:

$$\Sigma M_{p,columns} / \Sigma M_{p,conn} > 1.2 \quad (29)$$

In this equation the moment capacities of the columns should account for the decrease due to axial loads (Equation 18), while the moment capacity of the connections should be increased by 1.25 to account for the overstrength of the slab steel. The usual  $\phi$  factors should be included in this calculation, and thus the ratio of nominal capacities should be greater than 1.6.

- (2) The longitudinal slab steel should be kept within a column strip less than or equal to seven column flange widths. Tests have shown that the steel must be close to the column to be activated at low drifts. Since the intent is to obtain a connection that is stiff at service loads, the placement of the slab steel is a key detailing issue.
- (3) The slab steel should extend at least  $l_d$  plus 12 inches past the point of inflection or  $L/4$ , whichever is longest. At least two bars should be run continuously for unbraced frames governed by wind. At least two bars for the case where wind governs or one half of the steel for the case where seismic governs, should be run continuously for unbraced frames since the point of inflection can change drastically under seismic loading
- (4) The bar size should be kept small (between #4 and #6), and at least three bars on either side of the column should be used.
- (5) Transverse steel must be provided at each column line, and must extend at least 12 inches into the slab strip. To reduce serviceability problems a minimum of 0.05 in.<sup>2</sup> of steel per lineal foot must be provided over the girders, with this reinforcement extending at least 24 inches or 30 bar diameters, whichever is greater, on either side of the girder. Reinforcing transverse to the direction of the moment connection serves a structural purpose and deserves attention. Moments imposed by lateral loads cause a transfer of forces from the reinforcing to the column by means of shear in the slab and bearing at the columns. The transverse reinforcing, therefore, acts as concrete shear reinforcing for this mechanism and it is recommended that the area of the transverse reinforcing be made approximately equal to the main reinforcing.
- (6) The development of the equations for  $M-\theta$  curves for PR-CCs assumed that friction bolts (i.e., slip-critical) are used in the seat angle. The intent is not to prevent slip at service loads, but to minimize it.
- (7) Full shear connection in the form of headed shear studs should be provided. Partial shear connection can be used for non-seismic cases, but the designer is cautioned that there is no experimental evidence to justify any design guidelines in this area.

- (8) Other failure modes such as local buckling of the beam flange or web in negative moment regions, yielding of the column panel zone, bolt bearing stresses, and spacing requirements should be checked as per current specifications.

Because the reinforcing in the slab is an integral part of the connection, the quantity, spacing, and location of the reinforcing should be monitored very closely during construction.

## 8. REFERENCES

1. American Institute of Steel Construction, *Manual of Steel Construction, Load Resistance Factor Design*, 2nd Ed., 1994.
2. American Institute of Steel Construction, *Manual of Steel Construction, Allowable Stress Design*, 9th Ed., 1989.
3. Ackroyd, M. H., and Gerstle, K. H., "Strength and Stiffness of Type 2 Frames," *Report to the American Institute of Steel Construction*, University of Colorado, Boulder, 1977.
4. Gerstle, K. H., and Ackroyd, M. H., "Behavior and Design of Flexibly-Connected Building Frames," *AISC Engineering Journal*, 1st Qtr., 1990, pp. 22-29.
5. Ammerman, D. A., and Leon, R. T., "Behavior of Semi-Rigid Composite Connections", *AISC Engineering Journal*, 2nd Qtr., 1987, pp. 53-62.
6. Leon, R. T., Ammerman, D. J., Lin, J., and McCauley, R. D., "Semi-Rigid Composite Steel Frames," *AISC Engineering Journal*, 4th Qtr., 1987, pp. 147-155.
7. Leon, R. T., and Ammerman, D. J., "Semi-Rigid Composite Connections for Gravity Loads," *AISC Engineering Journal*, 1st Qtr., 1990, pp. 1-11.
8. Ammerman, D. J., and Leon R. T., "Unbraced Frames With Semi-Rigid Composite Connection," *AISC Engineering Journal*, 1st Qtr., 1990, pp. 12-21.
9. Leon, R. T., "Semi-Rigid Composite Construction," *J. of Constructional Steel Research*, Vol. 15, Nos. 1&2, 1990, pp. 99-120.
10. Leon, R. T., and Forcier, G. P., "Parametric Study of Composite Frames," *Proceedings of the Second International Workshop on Connections in Steel Structures* (R. Bjorhovde and A. Colson, eds.), AISC, Chicago, 1992, pp. 152-159.
11. Leon, R. T., and Zandonini, R., "Composite Connections," *Steel Design: An International Guide* (R. Bjorhovde, J. Harding and P. Dowling, eds.), Elsevier Publishers, November 1992, pp. 501-522.
12. Leon, R. T., "Composite Semi-Rigid Construction," *AISC Engineering Journal*, 2nd Qtr., 1994, pp. 57-67.
13. Johnson, R. P., and Law, C. L. C., "Semi-Rigid Joints for Composite Frames," in *Proc. Int. Conf. on Joints in*

- Structural Steelwork*, J.H. Hewlett et al. (eds.), Pentech Press, London, 1981, pp. 3.3-3.19
14. Zandonini, R., "Semi-Rigid Composite Joints," *Structural Connections: Stability and Strength*, (R. Narayanan, ed.), Elsevier Applied Science Publishers, 1989, pp. 63-120.
  15. Jaspert, J. P., Maquoi, R., Altmann, R. and Scheleich, J. B., "Experimental and Theoretical Study of Composite Connections," *IABSE Symposium on Mixed Structures including New Materials*, Brussels, Belgium, 1990, pp. 407-412.
  16. Azizinamini, A., Bradburn, J. H., and Radziminski, J. B., "Static and Cyclic Behavior of Semi-Rigid Steel Beam-Column Connections," *Report*, Department of Civil Engineering, University of South Carolina, March 1985.
  17. Johnston, B., and Mount, E., "Analysis of Building Frames with Semi-Rigid Connections," *Transactions of the American Society of Civil Engineers*, No. 2152, 1942, pp. 993-1019.
  18. Bjorhovde, R., "Effect of End Restraint on Column Strength—Practical Applications," *AISC Engineering Journal*, 1st Qtr., 1984, pp. 1-13.
  19. Liu, E., and Chen, W. R., "Steel Frame Analysis with Flexible Joints," *Journal of Constructional Steel Research*, Vol. 8, pp. 161-202.
  20. American Society of Civil Engineers, *Minimum Design Loads for Buildings and Other Structures*, ASCE, New York, NY, 1994.
  21. Hoffman, J. J., "Design Procedures and Analysis Tools for Semi-Rigid Composite Members and Frames," *M.S. Thesis*, Graduate School, University of Minnesota, December 1994.
  22. Goverdham, A. V., "A Collection of Experimental Moment-Rotation Curves and Evaluation of Prediction Equations for Semi-Rigid Connections," *Ph.D. Thesis*, Vanderbilt University, Nashville, TN, 1984.
  23. Kishi, N., and Chen, W. R., "Database of Steel Beam-to-Column Connections," *Structural Engineering Report CE-STR-86-26*, School of Civil Engineering, Purdue University, West Lafayette, IN, August 1986.
  24. Park, R., and Paulay, T, *Reinforced Concrete Structures*, John Wiley & Sons, New York, 1975, 769 pp.
  25. Chen, W. R., and Lui, E. M., *Stability Design of Steel Frames*, CRC Press, Boca Raton, FL, 1991.
  26. Lin, J., "Prediction of the Inelastic Behavior of Semi-Rigid Composite Connections," *M.S. C.E. Thesis*, University of Minnesota, October 1986.
  27. Kulkarni, P., "Analytical Determination of the Moment-Rotation Response of Semi-Rigid Composite Connections," *M.S.C.E. Thesis*, University of Minnesota, December 1988.
  28. Home, M. R., and Morris, L. J., *Plastic Design of Low-Rise Frames*, The MIT Press, Cambridge, Massachusetts, 1981.
  29. Leon, R. T., "Analysis and Design of Semi-Rigid Composite Frames," *Proceedings, III Simposio Internacional Y VI, Simposio Nacional de Estructuras de Acero*, Oaxaca, Mexico, November 1993.
  30. *ASCE-Manuals and Reports on Engineering Practice, No. 41, Plastic Design in Steel*, ASCE, New York, NY, 1971.
  31. ASCE Task Committee on Effective Length, "Effective Length and Notional Load Approaches for Assessing Frame Stability," *ASCE Technical Committee on Load and Resistance Factor Design*, ASCE, New York, 1996 (in press).

# Part II

## DESIGN PROCEDURES

### 1. INTRODUCTION

Two practical design procedures for designing PR-CCs are presented in this section. The first procedure is for PR-CC use in braced frames. In this case the connections provide continuity for composite beams or girders carrying gravity loads. The beam size or the amount of composite action required may be reduced because of the use of PR-CCs. Partial composite action is permitted in these members since they are not part of the lateral load resisting system. The second procedure presented is for PR-CC use in unbraced frames. This design is centered around providing enough connection stiffness to meet interstory drift criteria, as the frame's stiffness and not strength typically controls the design. For the main girders in the lateral load resisting system only use of full interaction is permitted.

Both procedures are based on a two-level approach; elastic analysis for service loads and plastic analysis for ultimate strength. This approach was chosen because of the nature of the moment-rotation relationship of PR-CCs. Under service loads the connections are approximated as linear elastic springs. At ultimate loads, plastic analysis is used because of its simplicity. Consequently, painstaking techniques to determine exactly where the connection is on the nonlinear moment-rotation are not necessary for ultimate strength checks. Beams are analyzed by plastic analysis as described in Part I. For unbraced frames, the capacity of the frame under nonproportional loading is determined by second-order plastic analysis as outlined in Part I.

The procedures are given in step-by-step outline form. For completeness all of the important steps are given. The design of a frame with PR-CC's only entails a departure from conventional design in the selection of the amount of end restraint and moment desired (Step 2 in the design of braced frames and Step 5 in the design for unbraced frames.) Both procedures are geared towards design using the AISC LRFD Manual and many references will be made to design provisions found in this manual. In addition, the Tables found in Part IV of this document will be referenced.

A few notes on the notation that is used throughout the procedures must be made. The dead load on the members is divided into the portion that is applied before composite action,  $DL_b$ , which includes weight of the slab, steel framing and decking, and the dead load after composite action,  $DL_A$ , which includes superimposed dead loads such as ceilings, mechanical systems, and partitions. The factored simply supported moment is denoted as  $M_u$ . The amount of composite

action in the beams is designated by the plastic neutral axis (PNA), as defined by AISC LRFD. Thus a PNA equal to the top of the top flange (TFL) is considered full composite action, and a PNA equal to position 7, as defined by AISC LRFD, is considered to be the minimum composite action (25 percent composite by LRFD).

### 2. DESIGN PROCEDURE FOR BRACED FRAMES

#### 2.1 Introduction

Partially restrained composite connections may be utilized in braced frames for beams framing into columns to reduce the beam size or amount of composite action required. In addition many of the filler beams can also be designed following this procedure. In many instances beams usually considered simply supported may be designed with PR-CCs with very few modifications in order to improve their deflection and vibration characteristics. The following paragraphs include a brief overview of this design procedure which is given in a step-by-step form in Section 2.2.

In the first step the minimum beam size is determined based on construction loading conditions, assuming unshored construction. In the second step the capacity of the bare beam chosen for construction conditions is compared with the requirements of ultimate strength and service deflections for a composite section based on the same beam. It is the aim of this procedure to utilize the beneficial effects of PR-CCs so that the "construction beam" may be adequate for ultimate strength and serviceability. Therefore, the second step is used to determine if (a) it is possible to use PR-CCs with the "construction beam", (b) the beam needs to be increased in size, or (c) the superimposed loads are so small that the "construction beam" is adequate at low composite action and semi-rigid connections are not required.

After the need for PR-CCs has been determined, the magnitude of end restraint required for strength and stiffness is determined in Step 3, and the connection is chosen. In Step 4 the connection details are established, including the seat angle, web angle, and connection reinforcement.

The ultimate strength of the connections is checked in Step 5 by plastic analysis. Finally, the connections are checked for compatibility at service loads. This is done to verify that the connections' rotations are less than that assumed for deflection checks.

Please refer to the Notation for definition of the terms used in the design procedures.

## 2.2 Recommended Design Procedure—Braced Frames

### STEP 1. Select Steel Beam Based on Construction Loads

Loading:

$$1.4DL_B + 1.6LL \rightarrow \text{Determine } M_{u,cons}$$

$$\text{Beam plastic capacity} = \phi M_{p,bare} \geq 0.9M_{u,cons}$$

The beam chosen in this step will be referred to as the "construction beam" and can be selected in a conventional manner. The 0.9 represents a 10 percent decrease in the simply supported moment due to some connection fixity during construction.

### STEP 2. Determine End Restraint Required

In this step it is determined if PR-CCs may be used. In Step 3 the size of the PR-CCs will be determined. The approach here is to try use the "construction beam" (not increasing the beam size) by providing enough end restraint to satisfy strength and stiffness criteria. In some instances the amount of end restraint required will be greater than available or practical and a larger beam will need to be chosen.

#### Step 2.1. Ultimate Strength Requirement:

Loading:

$$1.2(DL_B + DL_A) + 1.6LL \rightarrow \text{Determine } M_u$$

Determine

$$\phi M_{n,PNA7} = \text{capacity of composite beam with PNA} = 7$$

Determine

$$\phi M_{n,PNA1} = \text{capacity of composite beam with PNA} = 1 = \text{TFL}$$

If  $\phi M_{n,PNA7} \geq M_u$  then PR-CCs are not needed for strength.

If  $\phi M_{n,PNA7} < M_u$  then PR-CCs may be utilized.

If  $\phi M_{n,PNA1} \leq M_u$  then PR-CCs are needed for strength.

The construction beam is checked with the lowest recommended amount of composite action to determine if PR-CCs are needed for strength. If  $\phi M_{n,PNA7} < M_u$ , then PR-CCs may be used or the amount of composite action increased. If  $\phi M_{n,PNA1} < M_u$  then PR-CCs should be used or the "construction beam" increased.

#### Step 2.2. Service Deflection (Stiffness) Requirement

Establish live load deflection limit =  $\delta_{sr}$  (e.g.  $L/360$ )

Determine service loads (use of  $1.0D I_A + 1.0LL$  recommended)

Determine

$$I_{LB,PNA7} = \text{Lower bound moment of inertia (PNA7, LRFD Manual)}$$

Check

$$I_{LB,PNA7} \text{ against } I_{LB}(ss) \text{ and } I_{LB}(PR) \text{—see Sects. 2.2.1 and 2.2.2}$$

The moment of inertia of the composite beam with minimum interaction (25 percent) is checked against two lower bound moment of inertias,  $I_{LB}(ss)$  and  $I_{LB}(PR)$ . The first one,  $I_{LB}(ss)$ , defines adequacy as a simply supported beam and the second,  $I_{LB}(PR)$ , as a partially restrained beam.

#### Step 2.2.1. Required Simply Supported Moment of Inertia— $I_{LB}(ss)$

Use  $\delta_{ss}$  formulas from Table 3 (Part IV) to calculate  $I_{LB}(ss)$

#### Step 2.2.2. Required PR Moment of Inertia— $I_{LB}(PR)$

Determine what the relationship between the two end connections will be and use the appropriate equations below to calculate  $I_{LB}(PR)$ . For most interior beams the connections will be equal (Section 2.2.2a).

##### Step 2.2.2.a. Equal Connection Stiffnesses

$$\delta_{sr} = \delta_{ff} + \theta_{sym} L/4, \text{ with}$$

$$\text{Set } \theta_{sym} = 0.0025 \text{ radians and } I_{eq} = I_{LB}(PR) / 1.25$$

Since the  $I_{eq}$  (Equation 24, Part I) to be used in the deflection equation is dependent on the connection stiffness, which is unknown at this point, an approximate relationship is used between  $I_{eq}$  and  $I_{LB}(PR)$ . Similarly, the rotation at the service level is unknown, so  $\theta_{sym}$  is arbitrarily taken as 0.0025 radian. For this value of  $\theta_{sym}$ ,  $\delta_{sr} = L/360$ , and  $E = 29,000$  ksi, the required  $I_{LB}(PR)$  under a uniformly distributed load is  $ML/16.63$  where  $M = wL^2/8$ . In this relationship  $M$  and  $L$  are in kip and feet, while  $I_{LB}(PR)$  is in  $\text{in}^4$ .

##### Step 2.2.2.b. One End Pinned

$$\delta_{sr} = \delta_{ff} + \theta_{sym} L / 5.4$$

$$\text{Set } \theta_{sym} = 0.0025 \text{ radians and } I_{eq} = I_{LB} / 1.15$$

For  $\theta_{sym} = 0.0025$ ,  $\delta_{sr} = L/360$ , and  $E = 29,000$  ksi, the required  $I_{LB}(PR)$  under a uniformly distributed load is  $ML/9.375$  where  $M = wL^2/8$ . In this relationship  $M$  and  $L$  are in kip and feet, while  $I_{LB}(PR)$  is in  $\text{in}^4$ .

##### Step 2.2.2.C. Unequal Connection Stiffnesses

$$\delta_{sr} = \delta_{ff} + C_\theta \theta_{sym} L / 4$$

$$\text{Set } \theta_{sym} = 0.0025 \text{ radians and an assumed } C_\theta \text{ from Table 6}$$

$$\text{Set } I_{eq} = I_{LB} / 1.25$$

Determine relationship between  $I_{LB,PNA7}$  of the construction beam and the two lower bound moment of inertias calculated:

If  $I_{LB}(ss) < I_{LB,PNA7}$  No end restraint is required

If  $I_{LB}(sr) \leq I_{LB,PNA7} < I_{LB}(ss)$  PR-CCs may be used

If  $I_{LB,PNA7} < I_{LB}(sr)$  A larger beam or more composite action needed

If  $I_{LB,PNA7} < I_{LB}(sr)$ , choose a larger beam or more composite action, and recalculate  $I_{LB}$  for the corresponding PNA location. Then, determine where it falls in respect to  $I_{LB}(sr)$  and  $I_{LB}(ss)$  and proceed.

### STEP 3. Design PR-CCs for Gravity

If the beam analyzed in Step 2 requires an increase in strength, stiffness, or both, this step is used to choose a PR-CC to meet those requirements.

#### Step 3.1. Ultimate Strength Design

Calculate  $\phi M_{n,conn}$  and choose a connection with this strength from Table 1 (Part IV).

Step 3.1.1. If the beam has two PR-CCs then the required connection design strength is:

$$\phi M_{n,conn}(ave) = M_u - \phi M_{n,comp}$$

$\phi M_{n,comp}$  = composite beam strength (positive moment.)

The  $M_{n,conn}(ave)$  is the average connection strength of the two connections at the end of the beam. If the same connection is used at each end, then the average is the connection strength required at both ends.

Step 3.1.2. If one end is pinned:  $\phi M_{n,conn} = 2(M_u - \phi M_{n,comp})$

The following limits apply to the connection strength:

Step 3.1.3.a.  $\phi M_{n,conn} \leq$  Maximum connection strength available from Table 1

Step 3.1.3.b. For beams with two semi-rigid connections:

$$\phi M_{n,conn}(ave) \leq M_u \text{ based on } (1.2DL_A + 1.6LL)$$

For beams with one end pinned:

$$\phi M_{n,conn}(ave) \leftarrow 2M_u \text{ based on } (1.2DL_A + 1.6LL)$$

Step 3.1.3.c.  $M_{n,conn} / M_{p,bar} \leq 1.2$

Step 3.1.3.d.  $\Sigma Q_n(\text{composite beam}) \geq$  Force in connection (See Table 2, Part IV)

If any of these limits is not satisfied then more composite action or a larger beam must be used. Determine the new  $\phi M_{n,comp}$  and return to the beginning of this step.

#### Step 3.2. Stiffness Design

Use the smallest connection (6 #4 from Table 2, Part IV), unless a larger one is required for strength.

Calculate  $I_{eq}$  using Equation 24,  $I_{eq} = 0.6I_{LB(+)} + 0.4I_n$ , if there are two connections, or Equation 25,  $I_{eq} = 0.75I_{LB(+)} + 0.25I_n$ , if one end is pinned. Check that:

$$I_{eq} \geq I_{LB}(PR) / 1.25 \text{ for 2 connections or}$$

$$I_{eq} \geq I_{LB}(PR) / 1.15 \text{ for one connection}$$

where

$I_{LB}(PR)$  was determined in Step 2.

### STEP 4. Design Connection Details

#### Step 4.1. Seat Angle

The required angle area for the connection bending,  $A_p$  is listed in Table 2, Part IV. Check if a larger angle is required for the chosen connection type. Table 8, Part IV lists possible seat angle and bolt sets that have passed angle bearing and bolt shear requirements.

#### Step 4.2. Web Angle

The web angles must be designed for the factored shear corresponding to the critical gravity loading (typically,  $1.2(DL_B + DL_A) + 1.6LL$ ) and must have at least two bolts.

Whether or not gravity PR-CCs are designed with or without web angle depends on their use. Typically a stiffened seated beam connection is used on the weak axis of columns. Gravity PR-CCs with double web angles will commonly be used on the strong axis of columns in braced frames.

#### Step 4.3. Reinforcement

Reinforcement for gravity PR-CCs is to be detailed as described in Section 7, Part I.

### STEP 5. Determine Ultimate Strength by Plastic Analysis

Use Equation 16, Part I, and Table 7 to determine the beam load factor,  $\lambda_b$ . If  $\lambda_b$  is greater than one then the beam and connections are adequate for ultimate strength. If not, larger connections and/or beam are required.

### STEP 6. Establish Compatibility at Service Loads by Beam Line Analysis

Calculate actual connection rotation,  $\theta$ , by beam line analysis (Equations 3 and 5, Part I.), where  $K = MI/0.0025$ , and  $MI$  may be found in Table 2, Part IV. Note that loading is at service ( $1.0DL_A + 1.0LL$ ). If  $\theta \leq 2.5$  milliradians, then compatibility has been satisfied. If  $\theta > 2.5$  milliradians, then one of the following two steps must be taken:

Step 6.1. If  $I_{eq} > I_{LB}(sr) / 1.1$  then:

Step 6.1.1. Recalculate a new moment  $MI$  at  $\theta' = \theta + 0.5$

milliradian using Equation 1, Part I. Use A, from Table 2, Part IV, regardless of actual seat angle area.

*Step 6.1.2.* Recalculate  $\theta$  using the beam line equation with the new  $MI$ . Check if  $\theta \leq \theta'$ . Continue Steps 6.1.1 and 6.1.2 until this condition is met.

*Step 6.1.3.* Calculate service deflection using  $\theta'$ . Check to see if it is within the limits. If not, continue on to Step 6.2.

*Step 6.2.* If not, increase connection size and return to Step 3.

### 3. DESIGN PROCEDURE FOR UNBRACED FRAMES

#### 3.1 Introduction

This section outlines the steps required for design of PR-CCs in unbraced frames. Since the lateral stiffness requirements usually control over strength ones in unbraced frames with PR-CCs, this design procedure is a stiffness-based one. Many of the steps include here are not unique to design with semi-rigid connections, but have been included for completeness. The following paragraphs give a brief overview of the steps used in this procedure.

The procedure begins with determining column gravity loads and the lateral loads on the system, and then selecting preliminary column sizes based on strength (Steps 1-3). Next, the girders in the unbraced frame are sized for construction loads and the required moment of inertia for service deflections (Step 4). At this point, the connections are not chosen and the ultimate strength of the composite beam with PR-CCs is not evaluated. The construction beam size and composite beam moment of inertia are used in conjunction with the lateral stiffness requirements in Step 5 to determine the final beam and connection size.

The next step (Step 5) uses the approximate interstory drift equation presented in Appendix A, Part I to size the columns, girders, and connections for lateral stiffness requirements. This step uses a hand calculation approach. If a computer program with linear springs is available, then it may be more efficient to utilize it. In Step 6 the connection details are determined, including the bottom angle, bolts, and the web angle.

The beams and the frame as a whole are analyzed for ultimate strength by plastic analysis (Step 7). The loads used for plastic analysis are the factored load combinations. Therefore, calculated load factors of one or greater represent adequacy for plastic analysis.

The columns are checked for adequacy by the AISC LRFD interaction equations. For determining end restraint, an effective moment of inertia is used for the girders. Lastly, the beams are checked for compatibility under service gravity loads. This is done to determine the semi-rigid connection

rotation and verify the use of the linear spring approximation at 2.5 milliradians.

This procedure requires a plane frame program with linear spring elements for connections to calculate final values, including frame forces, interstory drifts, and unbalanced moments. At the user's discretion, the approximate methods used in this procedure for preliminary calculations may be used as final calculations for low-rise frames with no stiffness irregularities (NEHRP 1994).

#### 3.2 Design Procedure for Unbraced Frames

##### *STEP 1. Determine Column Loads*

This is done in the same manner as for frames without semi-rigid connections.

##### *STEP 2. Determine Lateral Loads and Approximate Lateral Moments*

###### *2.1. Lateral Loads*

The procedure for lateral loads is the same as for frames without semi-rigid connections, except when considering the actual frame period for unbraced frames under seismic loads.

Semi-rigid connections may increase the period of the building, in effect decreasing the amount of base shear. However, there are no current code provisions for estimating the fundamental period of a PR frame nor limits on the period increase allowed over that of a similar rigid frame. In lieu of calculating the fundamental period of a frame with semi-rigid connections, the code procedures for approximating rigidly connected frame periods may be used.

###### *2.2. Estimate Lateral Moments*

Use either the portal method (see Appendix A, Part I) or a preliminary frame analysis with linear springs for connections. Partial rigidity of the column to footing connection should be included in the frame analysis.

##### *STEP 3. Select Preliminary Column Sizes Based on Strength*

Consider the following load cases:

$$1.2DL+1.6LL$$

$$1.2DL + 0.5L + (1.3W \text{ or } 1.0E)$$

Using the approximate method given on page 3-11 of the 1994 LRFD Manual. A value for the  $K$  factor must be assumed ( $K=1.5$  usually provides a good initial estimate).

##### *STEP 4. Select Preliminary Beam Sizes Based on Gravity Requirements*

This step is used to determine the construction strength and service deflection requirements for the composite beams.



This step is similar to Step 2 in the design of braced PR-cCCs and the steps are not repeated here.

*STEP 5. Select Preliminary Beam, Column, and Connections by Lateral Drift Requirements*

Determine lateral interstory drift limit,  $\Delta_{total}$  (e.g. H/400)

Either the sum or average moment of inertia's of the beams and columns and the connection stiffnesses will be calculated next. If the frame has nearly the same gravity loading throughout a story, then the average values should be calculated and the same members and connections chosen for that story. For other circumstances the sum of inertia's and connection stiffnesses may be more appropriate. If a computer program with linear springs is available, and/or if the designer has experience with PR connections, a trial-and-error procedure may also be followed. For the purposes of discussion here a manual approach will be illustrated.

*Step 5.1. Columns*

Use Equation A-5, Part I to determine either the sum or average column moment of inertia's required for each story. Choose columns with moment of inertias near those required.

*Step 5.2. Beams and Connections*

*Step 5.2.1.* Calculate the sum or average beam moment of inertia,  $I_{eq}$ , for each story using Equations 24 or 25, Part I. If the exterior connection is pinned then only  $1/2$  may be used for the exterior beams contribution to the number of girders,  $N_g$ .

*Step 5.2.2.* Calculate the sum or average connection stiffness,  $K_{conn}$ , for each story using Equation A-6, Part 1.

*Step 5.2.3. Choose Connections and Beams*

Since  $I_{eq}$  is a function of both  $I_{LB}$  and  $I_n$ , the connection and girder will need to be chosen together. One approach to selecting the connection and girder is the following:

*Step 5.2.3.a.* Enter Table 1, Part IV and find a connection with  $K_{lap}$  approximately equal to  $K_{conn}$  for the desired beam depth. Note that the minimum beam depth that can be chosen is that from Step 4.

*Step 5.2.3.b.* Select a beam such that  $I_{LB} \approx 1.2I_{eq}(req'd)$ . If the design is for seismic forces then the beam must be fully composite; if it is for wind, the beam must be at least 75 percent composite. Note that the minimum beam size that can be chosen is from Step 4.

*Step 5.2.3.C.* Enter Table 7, Part IV to determine  $I_n$  and then calculate  $I_{eq}$  using the appropriate weighted formulas (Equations 24 and 25, Part I). Check that  $I_{eq}(calc) \approx I_{eq}(req'd)$ .

*STEP 6. Determine Connection Details*

*Step 6.1. Bottom Angle and Bolts*

Choose bottom angle and bolt sets for each connection from

Table 8. Check bearing on beam flange. If any other configuration is used all connection checks must be made.

*Step 6.2. Web Angles*

The same bolts chosen for the bottom angle should be used for the web angles to avoid confusion at the job site.

*Step 6.2.1.* Calculate the maximum web angle shear  $V_u$  by the capacity design approach as the largest of:

1.  $V_{grav}$  from  $1.2D + 1.6L$  or critical gravity load combination
2.  $V_{grav} + V_{lat}$ , from  $1.2D + 0.5L + (1.3W$  or  $1.0E)$  or critical lateral load combination.  $V_{lat}$  is computed based on capacity design:

$$V_{lat} = 2 \times M_{n,conn} / L$$

where

$M_{n,conn}$  = the nominal ultimate capacity of the connection (Table 1, Part IV) values divided by 0.85), and

$L$  = is the beam length.

*Step 6.2.2.* Determine adequate double angles using a minimum of 3 bolts and total area of both web angles,  $A_{wr}$ , greater than or equal to  $A_p$ , the area of the bottom seat angle. Web angles may be chosen from Table 9.2 of the 1994 LRFD Manual.

*Step 6.3. Column Stiffeners and Bearing*

Column stiffeners will seldom if ever be required in the design of PR-CCs.

Check sections K1.2 - K1.4, K1.6, and K1.7 of Chapter K of LRFD Specifications. See notes in Part I for a discussion on the forces to design for. The N distance used in Sections K1.3 and K1.4 (LRFD) may be taken as the  $k$  distance of the angles.

*Step 6.4. Connection Detailing*

The detailing requirements of Section 7, Part 1 must be followed.

*Step 6.5. Connection Summary*

The positive and negative connection strengths and the moment-rotation curve, if desired, are tabulated here for future use.

*Step 6.5.1. Negative Connection Strength,  $\phi M_n^-$*

Use the value from Table 1 or 2 or calculate by Equation 6, Part I, and include

$$\phi = 0.85$$

*Step 6.5.2. Positive Connection Strength,  $\phi M_n^+$*

Calculate using Equation 7, Part I, and  $\phi = 0.85$ .

### Step 6.5.3. Moment Rotation Curve

If a frame analysis using nonlinear connections will be used for final analysis, moment values by Equation 1, Part I at desired  $\theta$  values should be calculated.

### STEP 7. Check Ultimate Strength of Beams and Frames Using Plastic Analysis

Since the members and connections of unbraced frames are almost always controlled by stiffness requirements this ultimate strength check will rarely indicate inadequate beams and frames. Therefore, not much guidance is given for inadequate members and frames.

#### Step 7.1. Beams

Use Equation 15, Part I and Table 4, Part IV to determine the beam load factor,  $\lambda_b$ . If  $\lambda_b$  is greater than or equal to one then the beam and connections are adequate for ultimate strength. If not, larger connections and/or beam are required.

#### Step 7.2. Frames

Calculate the first order load factor,  $\lambda_p$  (Equation 17, Part I) and the approximate failure load,  $\lambda_f$  (Equation 19, Part I and Table 5, Part IV). The plastic moment capacity of the bottom story (base) columns must be reduced per Equation 18, Part I. If  $\lambda_f$  is greater than or equal to one then the frame is adequate. If the value is less than one, then larger frame members and/or connections must be chosen.

### STEP 8. Check Column Adequacy by Interaction Equations

Two approaches may be used to determine unbalanced moments for columns. Elastic frame analysis with rigid connections may be used as a conservative approach. A more accurate approach is to use a program that uses at least linear springs. It is suggested to use the second approach. When calculating column moments due to lateral loads a program with linear springs for connections is necessary for accurate results.

### Step 8.1. Unbalanced Moments

Note that the unbalanced moment is due to  $DL_A$  and  $LL$  and not loads before the curing of the concrete. If the column has semi-rigid connections in the weak axis direction, the unbalanced moment from these connections must also be considered.

### Step 8.2. Beam Moment of Inertias

Due to the presence of semi-rigid connections the beam moment of inertias must be changed to effective values,  $I_{eff}$ .

#### Step 8.2.1. Columns with PR-CCs on Both Sides

For the two beams framing into the column, the following two  $I_{eff}$  are used:

(a)  $I_{eff}(1) = 0$

(b)  $I_{eff}(2) =$  Equation 26, Part I, where  $K_{ult}$  is  $K_{lat}$  from Table 1, Part IV.

#### Step 8.2.2. Columns with One PR-CCS (typically exterior columns)

Assume that this is effectively a leaner column and  $K$  (factor) equal to 1.0.

### STEP 9. Establish Compatibility at Service Loads by Beam Line Analysis

Follow the same steps outlined in Step 6 of the recommended procedure for braced frames. If the connection size is increased then Steps 6, 8, and 9 must be redone.

### STEP 10. Determine the Number of Shear Connectors for Beams

The number of shear connectors must provide full composite action for beams in seismic design and at least 75 percent of full composite action for wind design.

This requirement is intended to insure that the assumptions made in developing Equations 24 through 27 are satisfied. Beams with low degrees of interaction have not been shown experimentally to provide adequate lateral stiffness.

# Part III

## DESIGN EXAMPLE

A four story office building with a penthouse was chosen for the design example. The design codes used are the 1993 ASCE-7 for loads and the AISC LRFD 1993 for member and frame design. For the seismic design portions of the new Chapter 7 of the 1994 NEHRP provisions were used. Details of the final frames designed are given in Figures E-1 through E-4.

### Gravity Loads

The floor framing system consists of composite metal decking supported by composite purlins and girders. The slab consists of a 2-in. composite deck with 3/4-in. lightweight concrete topping for a total thickness of 5 1/4-in. The main roof and penthouse floor are constructed with the concrete slab system. The penthouse roof is metal roof decking without a slab. The exterior wall consists of brick veneer with light gage back-up resulting in a wall weight of 50 psf. The penthouse wall is a lightweight metal panel, weighing 9 psf. The design loading is as follows:

(a) *Dead Load Before Composite Action (DL<sub>b</sub>):*

Slab	44 psf
Framing	6 psf
Total	50 psf

(b) *Dead Load After Composite Action (DL<sub>a</sub>):*

<i>Floors</i>	
Ceiling, Mech, Misc	15 psf

Partitions	20 psf
Total	35 psf

*Penthouse Floor*

Ceiling, Mech, Misc	15 psf
Penthouse Roof	32 psf

*Main Roof*

Ceiling, Mech, Misc	15 psf
Roofing Ballast and Insulation	15 psf
Total	30 psf

(c) *Live Loads*

Office Space	60 psf
Penthouse Floor	60 psf
Snow	30 psf

### Lateral Loads

The following are the applicable lateral loading code criteria:

- (a) *Wind:* 80 MPH, Exposure B  
Importance Factor = 1.0
- (b) *Seismic:*  $A_v = A_a = 0.2g$   
Site Factor,  $S = 1.2$   
Seismic Hazard Exposure Group = I

### Materials

Reinforcing: ASTM A615, Grade 60  
Beams: ASTM A572, Grade 50

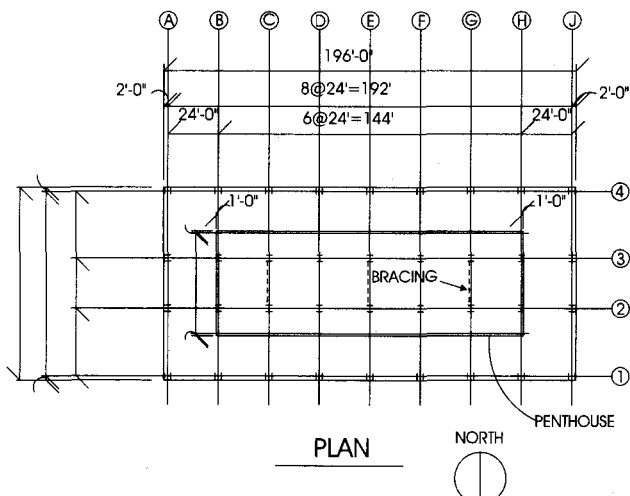

Figure E-1.

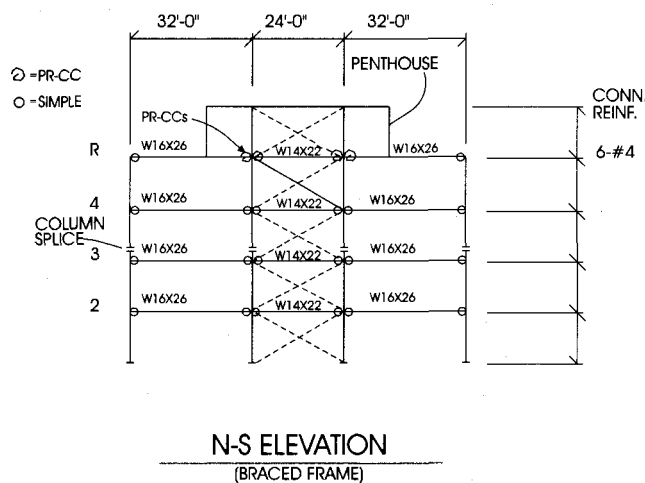

Figure E-2.

Columns: ASTM A572, Grade 50  
 Angles: ASTM A36  
 Concrete:  $f'_c = 3.5$  ksi (lightweight)

Figures E-1 through E-3 show the geometry of the building and the column layout. Figure E-4 shows a typical girder and purlin layout. The structure is unbraced in the E-W direction and braced in the N-S direction. PR-CCs are used on the strong axis of the columns in the E-W direction, utilizing all

four frames for the lateral resistance. In the N-S direction PR-CCs to the weak axis of the columns in the braced frame are considered. The slab edge at the perimeter is 24 inches beyond the grid centerline. The exterior connections at the exterior bays are taken to be pinned in the braced frame. In the unbraced frame PR-CCs are utilized to include the exterior columns and connections in resisting lateral loads.

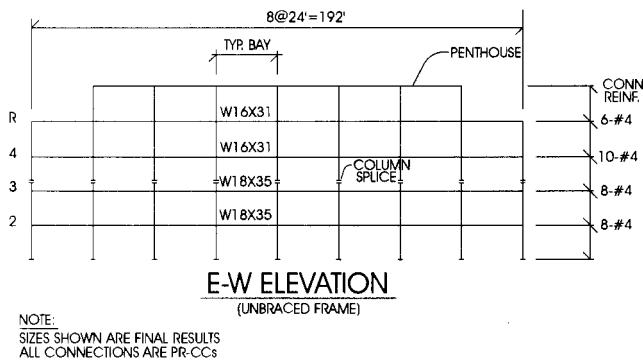

Figure E-3.

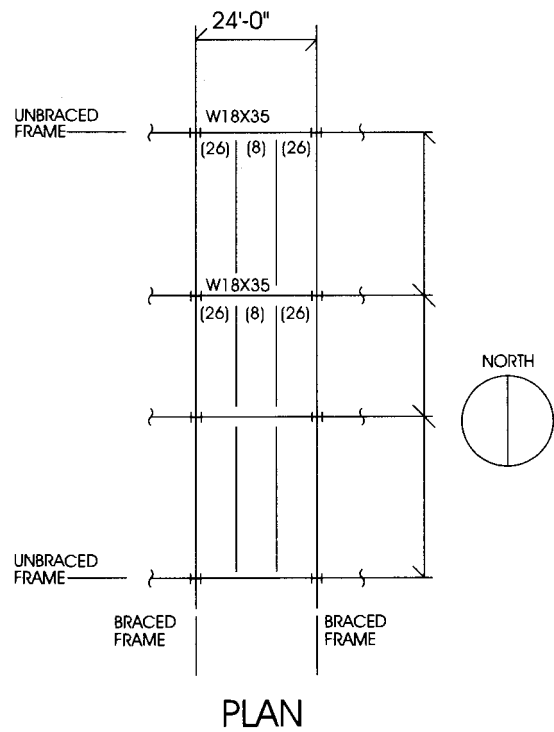

Figure E-4.

## PR-CCs IN BRACED FRAMES: N-S DIRECTION

### A. Steps 1 and 2—Composite Beam Design for Gravity Loads

The floor beams were designed for gravity loading. The following calculations show the computations for a typical interior floor purlin and an exterior roof beam. The latter was the only typical member to require PR-CCs.

#### (1) Typical Interior Bay Floor Purlin:

Direction: N-S  
 Member Type: Floor  
 Span (ft): 24  
 Trib. Width (ft): 8  
 Influence Area (sf): 384  
 LL Reduction (%): N/A

The design loads are as follows:

Load Case	Distributed Load (lb/ft)	V (k)	M (k-ft)	LF	Mu (k-ft)
$DL_B$	50 psf × 8 ft = 400	4.8	28.8	1.2	34.6
$DL_A$	35 psf × 8 ft = 280	3.4	20.2	1.2	24.2
LL	60 psf × 8 ft = 480	5.8	34.6	1.6	55.3
Total		13.9	83.5		114.0
Construction Loads					
$DL_B$	50 psf × 8 ft = 400		28.8	1.4	40.3
CLL	20 psf × 8 ft = 160		11.5	1.6	18.4
Total			40.3		58.8

#### Step 1. Construction Requirements

During the construction phase the loads on the bare steel beam can control the beam size. In addition to the strength requirement for construction, a stiffness requirement has also been included in this design. A construction deflection check including  $1.0DL_B$  and  $1.0CLL$  was carried out assuming a limit deflection of  $L/240$ .

$$M_{ser,cons} = M(DL_B + CL) = 40.3 \text{ kip-ft}$$

$$I_{s,min} = (Mcst \times 240L) / (161 \times 12)$$

$$= (40.3 \times 24 \times 240) / (161 \times 12)$$

$$= 120 \text{ in.}^4$$

Select W14×22 (lightest section in W14 group),  $I_s = 199 \text{ in.}^4$   
**o.k.**

$$\phi M_p = 125 \text{ k-ft} > 58.8 \text{ k-ft} \quad \text{o.k.}$$

The deflection of this beam under the construction loads is 0.52 inches and no cambering will be specified.

#### Step 2. Ultimate Strength (Completed Structure)

For checking ultimate strength  $Y2$ , the distance from the top flange of the beam to the centroid of the concrete in compression, is needed.  $Y2$  varies with the depth of the compression block. Two extremes were considered in design. When designing for full composite action the depth of the compression block is assumed to be the thickness of the slab above the decking and thus  $Y2$  is 3.5 in. ( $Y2 = 5.25 \text{ in.} - (3.25 \text{ in.}/2) = 3.63 \text{ in.}$  say 3.5 in.). When a minimal amount of composite action is required (PNA7), the depth of the compression block is assumed to be 1.5 inches and  $Y2$  is 4.5 inches. From the Tables in the LRFD Manual, for a W14×22 with  $Y2 = 4.5$  inches, and PNA=7:

$$\phi Mn = 172 \text{ k-ft} > 114.0 \text{ k-ft} \quad \text{o.k.}$$

The capacity of the studs with  $f'_c = 3.5$  ksi and weight of concrete at 115 pcf is 19.8 kips as per the AISC Specification. The maximum stud spacing is 8 times the total slab thickness ( $8 \times 5.25 = 42 \text{ in.}$ ) (LRFD Specification reference 15.6) assuming that steel deck to supporting steel members have fusion welds at 18" on center (LRFD Specification reference I3.5.b).

$$\Sigma Qn = 81.8 \text{ kips} = 4.1 \text{ studs} \geq \text{Use 12 studs total}$$

Serviceability (Completed Structure): Deflection Checks

$$I_{LB} = 367 \text{ in.}^4$$

$$\delta_{LL+DLA} = (20.2 + 34.6)24^2 / (161 \times 367) = 0.53 \text{ in.}$$

$$= L/543 < L/360 \quad \text{o.k.}$$

#### (2) Typical Exterior Bay Column Framed Beam

Direction: N-S  
 Member Type: Roof  
 Span (ft): 32  
 Trib. Width (ft): 8  
 Influence Area (sf): 256  
 LL Reduction (%): N/A

Load Case	Distributed Load (lb/ft)	V (k)	M (k-ft)	LF	Mu (k-ft)
$DL_B$	50 psf × 8 ft = 400	6.4	51.2	1.2	61.4
$DL_A$	35 psf × 8 ft = 280	4.5	35.8	1.2	43.0
LL	0.92 × 60 × 8 ft = 442	7.1	56.6	1.6	90.5
Total		18.0	143.6		195.0
Construction Loads					
$DL_B$	50 psf × 8 ft = 400		51.2	1.4	71.7
CLL	20 psf × 8 ft = 160		20.5	1.6	32.8
Total			71.7		104.4

These members also carry the following loads from the penthouse:

$$(a) \text{ Penthouse Column: Trib. Area} = 6 \text{ ft} \times 24 \text{ ft} = 144 \text{ sf}$$

$$P-DL_A = 32 \text{ psf} \times 144 = 4.6 \text{ kips}$$

$$P-LL = 30 \text{ psf} \times 144 = 4.3 \text{ kips}$$

(b) Penthouse wall: Trib. Width = 8 ft  
 $P-DL_A = 15 \text{ lb/ft} \times 8 \text{ ft} = 0.12 \text{ kips}$

In addition, part of these members acts as a roof so snow loads must be accounted for. The snow load is 30 psf, but the snow drift adjacent to penthouse wall results in an increase from 30 psf to 74 psf in the last 10 ft. The total loads are summarized below:

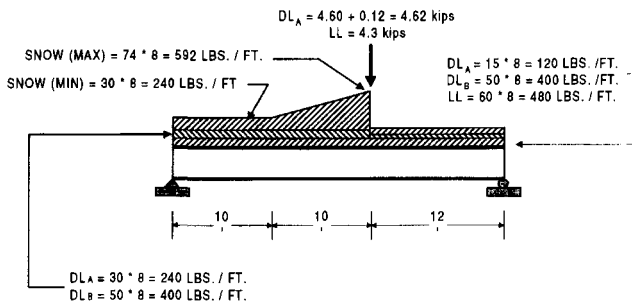

The total moments are:

$$M-DL(b) = 51.2 \times 1.2 = 61.4 \text{ k-ft}$$

$$M-DL(a) = 59.0 \times 1.2 = 70.8$$

$$M-LL = 82.8 \times 1.6 = 132.5$$

$$\text{Total} = 264.7 \text{ kip-ft}$$

Following the calculations for the interior purlin shown above:

### Step 1. Construction Requirements

$$M_{ser,cons} = M(DL_B + CL) = 71.7 \text{ kip-ft}$$

$$I_{s,min} = (M_{cst} \times 240L) / (161 \times 12)$$

$$= (71.7 \times 32 \times 240) / (161 \times 12)$$

$$= 285 \text{ in.}^4$$

Select W 16x26 (lightest section in W16 group),  $I_s = 301 \text{ in.}^4$  **o.k.**

$$\phi Mp = 166 \text{ k-ft} > 104.4 \text{ k-ft} \quad \text{**o.k.**}$$

### Step 2. Ultimate Strength (Completed Structure)

From the Tables in the LRFD Manual, for a W16x26 with  $Y_2 = 4.5$  inches, and  $PNA=7$ :

$$\phi Mn = 227 \text{ k-ft} < 264.7 \text{ k-ft} \quad \text{not o.k.} \rightarrow \text{Use PR-CC or more composite action}$$

### Serviceability (Completed Structure)

From the Tables in the LRFD Manual, for a W 16x26 with  $Y_2 = 4.5$  inches, and  $PNA=7$ :

$$I_{LB,PNA7} = 535 \text{ in.}^4$$

$$M_{ser} = (59.0 + 82.8) = 141.8 \text{ kip ft.}$$

$$I_{LB(ss)} = (M \times L \times 360) / (161 \times 12) = 846 \text{ in.}^4$$

$$I_{LB(PR)} = (M \times L) / 9.375 = (141.8 \times 32 / 9.375) = 484 \text{ in.}^4$$

Note that since this is a member framing into an exterior column, one end is pinned and the other can be PR.

$$\text{Since } I_{LB,PNA7} < 846 \text{ in.}^4 \text{ and } > 484 \text{ in.}^4 \rightarrow \text{Use PR-CC}$$

### (3) Summary

The table below shows the final member sizes that have been chosen. The types of beam connections are denoted as pinned (PIN) or partially restrained composite (PRCC). If only one beam is listed then the column framed beam did not necessitate partially restrained connections. Parenthesis indicate the total number of shear connectors (studs) on a beam.

Beam Locations	Connections	Beam and Studs	$M_u$ (kip-ft)	$L/B$ (in.)
Interior bay floor	PIN-PIN	W14x22 (12)	114	367
Exterior bay floor	PIN-PIN	W16x26 (16)	195	622
Interior bay roof	PRCC-PRCC	W14x22 (12)	100	348*
Exterior bay roof	PIN-PIN	W18x35 (16)	265	877
Exterior bay	PRCC-PIN	W16x26 (16)	265	513*

## B. Step 3. Connection Design

From Steps 1 and 2 it has been determined that only the exterior roof beam requires a larger beam or utilization of PR-CCs over what is required for construction conditions. Since it is not typical to design for one semi-rigid connection and one pinned connection on opposite sides of an interior connection, two options may be considered. Either the exterior beam is increased in size or the amount of composite action (in this case a W18x35, PNA 7 would be required), or the connection to the interior beam is also made semi-rigid. The second option will be selected out here to show the use of Steps 3 through 6. The calculations for the interior beam will be included where appropriate.

Step 3 is used to calculate the required moment at the connection and to check if the equivalent beam moment of inertia is greater than that approximated in Step 2. The amount of moment that can be utilized at the connection is limited by (a) the maximum connection strength available, (b) the amount of moment that can be transmitted after the curing of the concrete, (c) the strength of the beam at its ends, and (d) the amount of force that can be transmitted through composite action of the beam.

### A) Ultimate Strength Design

Interior Beam: W14×22,  $L = 24$  ft

Assume  $Y_3 = 5\frac{1}{4}$  in. - 1 in. =  $4\frac{1}{4}$  in., say  $Y\# = 4$  in.

Use 6 #4 connection  $\rightarrow \phi M_{n,conn} = 125$  k-ft (Table 1, Part IV)

This connection is not needed for strength or stiffness, so this connection passes checks (a) and (b) limits for the design procedure as stated in Part II. Check (c) and (d):

c)  $M_{n,conn} / M_p = 120 / 139 = 0.86 < 1.2$  o.k.

d)  $\Sigma Q_n = 81.1$  kips  $> 72$  kips = Force (Table 1, Part IV)

Exterior Beam: W5W16×22,  $L = 32$  ft

Required  $\phi M_{n,conn} = 2(M_u - \theta M_{n,comp}) = 2(265 - 227) = 76$  k-ft

Choose 6 #4  $\rightarrow \phi M_{n,conn} = 125$  kip-ft (Table 2, Part IV)

Limits on Connection Strength:

a)  $\phi M_{n,conn} = 125$  kip-ft (provided)  $> \phi M_{n,conn} = 76$  k-ft (required) o.k.

b)  $\phi M_{n,conn} = 125$  kip-ft  $< 2(1.2DL_A + 1.6LL) = 406.6$  k-ft o.k.

c)  $M_{n,conn} / M_p = 125 / 166 = 0.75 < 1.2$  o.k.

d)  $\Sigma Q_n = 96$  kips  $> 72$  kips = Force (Table 1, Part IV)

### B) Stiffness Design

Interior Beam:

$I_n = 319$  in.<sup>4</sup> (Table 7, Part IV)

$I_{eq} = 0.6I_{LB} + 0.4I_n = 0.6(367) + 0.4(319) = 345$  in.<sup>4</sup>

Exterior Beam:

$I_n = 447$  in.<sup>4</sup> (Table 7, Part IV)

$I_{eq} = 0.75I_{LB} + 0.25I_n = 0.75(535) + 0.25(447) = 513$  in.<sup>4</sup>

Check that  $I_{eq}$  is greater than the assumed value of  $I_{LB} / 1.15$ :

$I_{eq} = 513$  in.<sup>4</sup>  $> I_{LB}(PR) / 1.15 = 484 / 1.15 = 421$  in.<sup>4</sup>

### C. Step 4. Connection Design

In this step the seat angle, bolts, reinforcement, and double web angles are designed for the chosen connection. If the seat angle is to provide shear resistance its area must meet the requirements for the particular type of connection. The seat angle must be designed for the most critical case, either shear or for the moment arm force.

### A) Seat Angle

Interior Beam:

Area required for PR-CC =  $2.0$  in.<sup>2</sup> (Table 1, Part IV)

Area required for seated beam =  $8$  in.  $\times$   $\frac{3}{8}$  in. =  $3.0$  in.<sup>2</sup> (LRFD, Table 9-6)

$V_u = 16.8$  kips,  $t_w = 0.23$  in.

Use a L6×4× $\frac{3}{8}$ ×8 in. seat angle

Use 4  $\frac{3}{4}$  A325N bolts

$4 \times (\phi V_n / 0.8) = 4 \times (15.9 / 0.8) = 79.5$  kips  $> 72$  kips = Force (Table 1, Part IV)

Note that the LRFD tabulated values have been increased by 1/0.8 to account for connection length less than 10 inches.

Exterior Beam:

Area required for PR-CC =  $2.0$  in.<sup>2</sup> (Table 1, Part IV)

Area required for seated beam =  $8$  in.  $\times$   $\frac{1}{2}$  in. =  $4.0$  in.<sup>2</sup> (LRFD, Table 9-6)

$V_u = 30.1$  kips,  $t_w = 0.25$  in.

Use a L6×4× $\frac{1}{2}$ ×8 in. seat angle

Use 4  $\frac{3}{4}$  A325N bolts:

$4 \times (\phi V_n / 0.8) = 4 \times (15.9 / 0.8) = 79.5$  kips  $> 72$  kips = Force (Table 1, Part IV)

### C) Reinforcement

Interior Beam: 6 #4 bars as main longitudinal reinforcement, placed within 7 column flanges and extended  $L/4 = 6$  ft into span

Exterior Beam: 6 #4 bars as main longitudinal reinforcement, placed within 7 column flanges and extended  $L/4 = 8$  ft into span

Interior and Exterior Beams: #3 @ 18 inches as serviceability reinforcement, placed outside main longitudinal reinforcement and extended 2 ft on each side of the column line.

Transverse Reinforcement: 3 #4 on each side of the column, placed within 7 column flanges and extended 12 ft past main reinforcement

### D. Step 5. Check on Ultimate Strength by Plastic

Plastic analysis is used to simply determine if the beam is adequate at ultimate loads. Table 4 is used for most general cases.

Interior Beam:

$M_{p,b} = 172$  k-ft



$$M_{p,c1} = 125 \text{ k-ft}$$

$$w = 1.392 \text{ k/ft} = 1.2(DL_B + DL_A) + 1.6LL$$

Using load case 5 for  $M_{p,c1} = M_{p,c2}$  from Table 4, Part IV, and Equation 16, Part I:

$$\lambda_b = \{8/(1.392 \times 24^2)\} \times (125 + 172) = 2.96 > 1.0 \quad \text{o.k.}$$

Exterior Beam:

$$M_{p,b} = 227 \text{ k-ft}$$

$$M_{p,c1} = 125 \text{ k-ft}$$

$$X = 0.37L = 11.9 \text{ ft (Equation for X, Table 4, Part IV)}$$

$$\text{Using equivalent loads, } w \text{ (equiv)} = 2.083 \text{ k/ft}$$

Using load case 5 for  $M_{p,c2} = 0$  from Table 4, Part IV, and Equation 16, Part I:

$$\lambda_b = \{2 \times 32 / (2.083 \times 32^2 \times (32 - 11.9))\} \times (125 + (32/11.9) \times 227) = 1.10 > 1.0 \quad \text{o.k.}$$

### E. Step 6. Beam-Line Analysis

The last step for semi-rigid beams in braced frames is to determine if the assumption that the rotation at service is less than or equal to 2.5 milliradians is correct. If  $\theta_{ser}$ , the rotation at service, is larger than 2.5 milliradians then a further analysis into what the actual rotation is must be conducted. In this case a check to insure that the service deflection requirement is still met must also be carried out.

For this beam line analysis,  $M_f$  and  $\theta_{ss}$  are calculated by hand for the exterior beam due to the non-symmetric loading. Typically these values would be computed from Table 3, Part IV.  $MI$  is taken from Table 2, Part IV, (is computed from Equation 5, Part I, and  $M$  from Equation 3, Part I.

Input						Calc. Values		Beam Line	
Level	Beam Loc.	L (ft)	I <sub>eq</sub> (in. <sup>4</sup> )	w (k/ft)	MI (k-ft)	M <sub>f</sub> (k-ft)	θ <sub>ss</sub> (mrad)	θ <sub>ss</sub> (mrad)	M (k-ft)
Roof	Int	24	348	0.6	82.7	28.8	4.93	0.74	24.5
Roof	Ext	32	513	—	91.9	146.8	12.96	3.05	112.2

Note that the roof exterior beam exceeds the limit rotation of 0.25 milliradians, and thus further checks are necessary. Use the approach described in Step 6, Part II:

$$(a) \theta' = 3.05 + 0.5 = 3.55 \text{ milliradians}$$

(b) Recalculate:  $MI = 101.2 \text{ kip-ft}$  (from Equation 1, Part I)

$$M_f = 146 \text{ kip-ft}$$

$$\theta_{ss} = 12.96 \text{ milliradians}$$

$$\theta = 3.48 \text{ milliradians}$$

$$M = 107.6 \text{ kip-ft}$$

(c) Check deflection with  $\theta' = 3.55$  milliradians:

$$\delta = \delta(\text{FR}) + \theta' L / 5.4$$

Use  $w$  (equiv.) = 1.147 k/ft

$$\delta = 1.01 \text{ in} < L/360 = 1.07 \text{ in.} \quad \text{o.k.}$$

### Braced Frame Design: Beam and Connection Summary

(a) Interior Beam:

Beam: W14×22, 12 studs total, no camber

Connection: 6 #4 bars, L6×4×<sup>3</sup>/<sub>8</sub>×8-in. seat angle, 4<sup>3</sup>/<sub>4</sub> A325N bolts

(b) Exterior Beam:

Beam: W16×26, 16 studs total, 1 inch camber

Connection: 6 #4 bars, L6×4×<sup>1</sup>/<sub>2</sub>×8-in. seat angle, 4<sup>3</sup>/<sub>4</sub> A325N bolts

# PR-CCs IN UNBRACED FRAMES: E-W Direction

## A. Step 1. Column Loads:

The design of the unbraced frames entails first a determination of the gravity loads in the columns so that a preliminary estimate of the column sizes can be made. The following table summarizes these calculations (all loads are in kips).

Col	Level	Service DL	Service LL	Load Comb1	Load Comb 2	Load Comb 3
Typ Int <i>A</i> = 672	4-R	77	51	175	118	126
	3-4	136	73	280	199	213
	2-3	194	91	379	279	298
	1-2	253	108	477	358	383
Typ Ext Line 1 <i>A</i> = 384	4-R	42	15	74	58	62
	3-4	92	29	157	125	134
	2-3	142	41	236	191	205
	1-2	175	52	294	237	254
Typ Ext Line A <i>A</i> = 336	4-R	32	10	55	44	47
	3-4	80	23	134	108	116
	2-3	129	34	209	172	184
	1-2	158	44	261	212	228
Corner <i>A</i> = 192	4-R	21	6	34	28	30
	3-4	57	15	92	76	81
	2-3	93	22	147	122	132
	1-2	110	29	178	147	158
Int Corner <i>A</i> = 672	4-R	62	36	132	93	99
	3-4	121	58	237	174	186
	2-3	179	76	337	253	271
	1-2	238	93	434	332	356

**Notes**

1. The area given (*A* =) represents the most typical area for the column. The interior corner column is the first interior column in both directions such as B-2.
2. Load Combination 1 is 1.2*D* + 1.6*L*; Load Combination 2 is 1.2*D* + .5*L*; Load Combination 3 is 1.3*D* + .5*L* (seismic combination, ASCE 7, Sec 2.4.2, Eq. 5).
3. The table values include live load reductions per ASCE 7-93.

## B. Step 2. Lateral Loads

### (1) Wind Loading (ASCE 7-93, Chapter 6)

The wind loads correspond to an 80 mph, Exposure B structure and the following parameters:

- L* / *B* = 2.1
- C<sub>p</sub>* (windward) = 0.8
- C<sub>p</sub>* (leeward) = -0.3
- G<sub>h</sub>* = 1.37
- GC<sub>p</sub>* = 0

The wind forces for the E-W direction were calculated as follows:

The calculations assume that the wind forces are distributed according to the tributary areas of the frames. The interior frames are assumed to have a tributary width of 28 ft

while the exterior ones have a tributary width of 16 ft. More details of the wind forces and the relevant calculations are shown in Figure E-5.

Level	Trib (ft)	Wind/ft (lb/ft)	V (k)	Sum V (k)	Interior Bays		Exterior Bays	
					V per bay (k)	Sum V per bay (k)	V per bay (k)	Sum V per bay (k)
R-P	50	115	5.8	—	1.8	—	1.0	—
4-R	42/50	156/218	17.5	23.2	5.6	7.4	3.2	4.2
3-4	92	199	18.3	41.6	5.8	13.2	3.3	7.6
2-3	92	176	16.2	57.8	5.2	18.4	2.9	10.5
1-2	92	155	14.2	72.0	4.5	22.9	2.6	13.1

### (2) Seismic Forces (ASCE 7-93 and NEHRP 1994)

The design for seismic forces will be made as per ASCE 7-93, but the *R* factor will be taken from the NEHRP 1994 provisions. The latter is the only document that currently assigns both an *R* factor (*R* = 6) and a *C<sub>d</sub>* factor (*C<sub>d</sub>* = 5.5) to PR-CCs frames. In the computations the period of the structure is taken as that of a fully rigid frame since the codes do not contain any guidelines on estimating the fundamental period for PR frames. This assumption results in larger forces and is therefore conservative.

The following quantities were used in the ASCE 7-93 calculations:

*A<sub>v</sub>* = 0.20

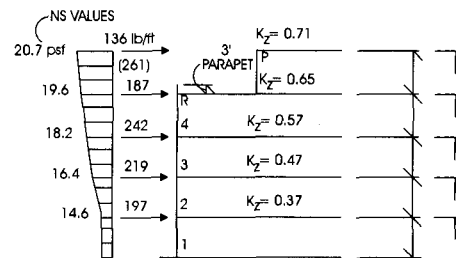

ELEVATION

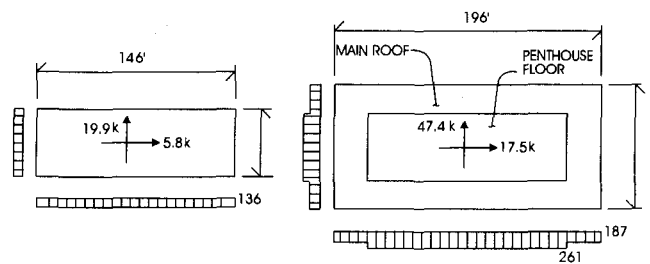

PENTHOUSE PLAN

ROOF PLAN

WIND LOADS

Figure E-5.

$$R = 6$$

$$S = 1.2$$

$$I = 1.0$$

Using the approximate period (Equation 9.4-6, ASCE 7-893):

$$T(\text{actual}) \leq C_a \times T_a, C_a = 1.4 \text{ (Table 9.4-1)}$$

$$T_a = C_t \times (h_n)^{3/4}$$

$$C_t = 0.035$$

$$h_n = 53.33 \text{ ft}$$

$$T_a = 0.035(53.33)^{3/4} = 0.69 \text{ sec}$$

$$k = 1.10$$

$$C_s = 0.0614 < 0.083 \text{ max}$$

$$V = 0.0614W$$

The building masses to be used in calculating  $W$  were taken as follows:

Slab and framing DL	50 psf
Miscellaneous equipment on penthouse floor	25 psf
Storage	0 psf
Partitions	16 psf
Permanent equipment	15 psf
Snow load	0 psf

Note that this building was intended as an outpatient clinic for a health maintenance organization and that the operating rooms were in the penthouse. This results in some large equipment loads (25 psf additional) in this area which were initially considered as part of the live loads for the gravity design. For seismic design, however, this equipment was considered to be part of the permanent loads on the structure.

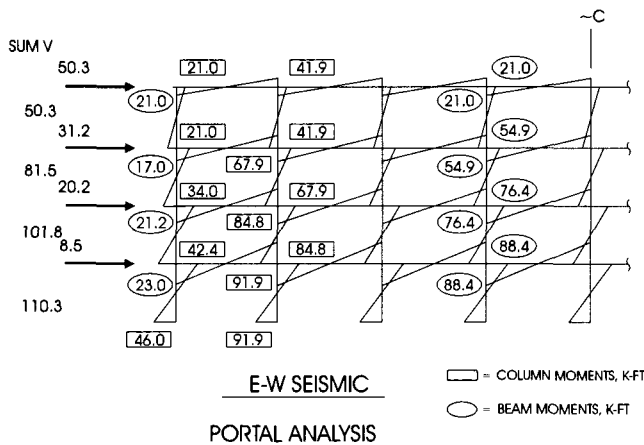

Figure E-6.

Level	Framing			Wall		Part (k)	Equip/Misc (k)	Total (k)	Sum (k)
	Area (ft <sup>2</sup> )	PSF	DL (k)	Area (ft <sup>2</sup> )	DL (k)				
Pent	6900	32	221	5120	49	—	104	373	373
Roof	17200	50	860	3840	192	110	515	1678	2051
4th	17200	50	860	7680	384	275.2	258	1777	3828
3rd	17200	50	860	7680	384	275.2	258	1777	5605
2nd	17200	50	860	7680	192	275.2	258	1585	7190

The distribution of the horizontal shears is as follows:

Level	(k)	h (ft)	w x h <sup>*</sup>	Cvx	H (k)	Sum f <sub>x</sub> (k)
Roof	2051	53.33	159869	0.45	200	200
4th	1777	40.00	101110	0.29	126	326
3rd	1777	26.67	64855	0.18	81	408
2nd	1585	13.33	27060	0.08	34	441
Sum	7190	—	352895	1.00	441	—

Figure E-6 shows the distribution of forces from a simplified portal analysis for the forces calculated above. Each of the four frames in the E-W direction was assumed to carry one-quarter of the load.

### C. STEP 3. Preliminary Column Sizes Based on Strength:

The preliminary column design is made assumed that the strong axis will govern and that the effective length factor,  $K$ , can be taken as 1.5 for preliminary design. The numbers 1 and 3 in this table and other tables in this section refer to the ASCE load combinations. Load Combination 1 is  $1.2D + 1.6L$ ; Load Combination 3 is  $1.3D + .5L$  (seismic combination, ASCE 7, Sec 2.4.2, Equation 5). The following tables summarize the results of the column design procedure, following the approach given on p. 3-11 of the LRFD Manual.

(1) Exterior Frame: Typical column (Line 1)

Level	KL (ft)	Pu (k)		M (k-ft)	m	Pu-eff (k)		Size
		1	3			1	3	
4-R	20	74	62	41.9	1.3	74	116	W10x49
3-4	20	157	134	67.9	1.3	157	222	W10x49
2-3	20	236	205	84.8	1.3	236	315	W12x65
1-2	20	294	254	91.9	1.3	294	373	W12x65

(2) Exterior Frame: Corner column

Level	KL (ft)	Pu(k)		M (k-ft)	m	Pu-eff(k)		Size
		1	3			1	3	
4-R	20	34	30	21.0	1.3	34	57	W10x33
3-4	20	92	81	34.0	1.3	92	125	W10x33
2-3	20	147	132	42.4	1.3	147	187	W10x49
1-2	20	178	158	46.0	1.3	178	218	W10x49

(3) Interior Frame: Typical interior column

Level	KL (ft)	Pu(k)		M (k-ft)	m	Pu-eff(k)		Size
		1	3			1	3	
4-R	20	175	126	41.9	1.3	175	180	W10x49
3-4	20	280	213	67.9	1.3	280	301	W10x49
2-3	20	379	298	84.8	1.3	379	408	W12x65
1-2	20	477	383	91.9	1.3	477	502	W12x65

(4) Interior Frame: Typical corner column

Level	KL (ft)	Pu(k)		M (k-ft)	m	Pu-eff(k)		Size
		1	3			1	3	
4-R	20	132	99	41.9	1.3	132	153	W10x49
3-4	20	237	186	67.9	1.3	237	274	W10x49
2-3	20	337	271	84.8	1.3	337	381	W12x65
1-2	20	434	356	91.9	1.3	434	475	W12x65

(5) Preliminary Estimate of P-Δ Effects (ASCE 7-93, Section 9.4.6.2)

This is a preliminary check to determine if stability effects will be important. Note that all columns are assumed to participate in carrying the lateral loads; thus there are no leaning columns in this system. Typical column loads were used and a maximum drift of 2 percent assumed.

Level	H (in.)	Int	Ext 1	Ext 2	Cor	Int-Cor	Sum P	Sum Fx	Delta (in.)	—
4-R	160	1028	695	149	94	321	2287	194	2.56	0.034
3-4	160	1722	1493	369	257	599	4439	313	3.20	0.052
2-3	160	2400	2273	583	415	870	6541	389	3.20	0.061
1-2	160	3070	2821	722	498	1137	8248	420	3.20	0.071

From these computations it appears that P-Δ effects will not govern since  $\theta < 0.1$ . These calculations are based on assuming rigid connections and thus a more detailed analysis will be required latter to verify the stability limit state.

**D. STEP 4. Composite Beam Design for Gravity**

The floor beams were designed for gravity loading just as for the braced frame case. The following calculations show the computations for a typical interior floor girder. The biggest differences between this member and those designed for the

braced case is that (a) full composite action and (b) the presence of PR-CCs will be assumed since this member is part of the lateral load resisting system:

Direction: E-W  
 Member Type: Floor girder  
 Span (ft): 24  
 Trib. Width (ft): 8 (per purlin)  
 Tributary Area (sf): 448 (2 purlins x (12 ft + 16 ft) x 8 ft)  
 Influence Area (sf): 896  
 LL Reduction (%): 0.24

Load Case	P (k)	V (k)	M (k-ft)	LF	Mu (k-ft)
$DL_B$	50 psf x 224 = 11.2	11.2	89.6	1.2	107.5
$DL_A$	35 psf x 224 = 7.8	7.8	62.7	1.2	75.3
LL	.76x60x224=11.1	11.1	88.8	1.6	142.1
Total		30.1	241.1		<b>324.9</b>
Construction					
$DL_B$	11.2		89.6	1.4	125.4
Const LL	20 psf x 224 = 4.5	4.5	35.8	1.6	57.3
Total			125.4		<b>182.8</b>

Following the calculations for the braced case:

Construction Requirements:

$$M_{ser,cons} = M(DL_B + CL) = 125.4 \text{ kip-ft}$$

$$I_{s,min} = (M_{cst} \times 240L) / (161 \times 12)$$

$$= (125.4 \times 24 \times 240) / (161 \times 12)$$

$$= 373 \text{ in.}^4$$

Select **W16x31**,  $I_s = 375 \text{ in.}^4$  **o.k.**

$$\phi Mp = 203 \text{ k-ft} > 182.5 \text{ k-ft} \text{ o.k.}$$

Note that this member, designed by ultimate strength, is very close to yielding ( $SF_y = 196.6 \text{ kip-ft}$ ) at the full factored construction load. Although the current LRFD Specification does not require a check on yielding, the latter is highly recommended.

Ultimate Strength (Completed Structure):

From the Tables in the LRFD Manual, for a W16x31 with  $72 = 3.5 \text{ in.}$ , and PNA= 1 (TFL):

$$\phi Mn = 370 \text{ k-ft} < 324.9 \text{ k-ft} \text{ o.k.}$$

Serviceability (Completed Structure):

From the Tables in the LRFD Manual, for a W16x31 with  $Y2 = 3.5 \text{ in.}$ , and PNA=1(TFL):

$$I_{LB,PNA1} = 972 \text{ in.}^4$$

$$M_{ser} = (62.7 + 88.8) = 150.5 \text{ kip-ft.}$$

$$I_{LB,Required} = (M \times L) / 14.97 = (150.5 \times 24 / 16.63) = 217 \text{ in.}^4$$

Since  $I_{LB,PNA1} > I_{LB,Required}$  there is no need for PR-CC's for gravity loads. They will be present in this member, however, because it is part of the lateral load resisting system.

Similar calculations indicated that the following sections would work:

Exterior Frame: Floor—W 16x26  
 Roof—W16X26  
 Interior Frame: Floor—W16x31  
 W16x31

### E. Step 5. Preliminary Member Sizes Based on Lateral Drift Requirements

The girders, columns, and connections were chosen for a typical E-W frame based on seismic drift requirements. The allowable elastic interstory drift under the full lateral load is  $0.02h / C_d$  (ASCE 7-93), where  $h$  is the story height and  $C_d$  is the deflection amplification factor. With  $C_d$  equal to 5.5 and  $h$  equal to 13 ft 4 in., the interstory drift limit is 0.582 inches. This design can be carried out by trial-and-error using a computer program with linear springs or by using the portal method and simplified equations such as those given in Part I. A hand-calculation procedure, using Equations A-5, A-6 and A-7, from Appendix A, Part I, was used here. Since the girder's equivalent moment of inertia ( $I_{eq}$ ) is dependent on the connection ( $I_n$ ), the approximate relationship of  $I_{eq} = I_{LB} / 1.2$  was used. Connections have been chosen from Table 1, Part IV with stiffnesses ( $K_{lat}$ ) near those computed below.

Floor	Height (in.)	Sum $V_i$ (k)	Calculated Values			
			Columns $I(ave)$	Connect $K(ave)$	Girders $I(ave)$	Approx.
R	160	50.3	343	34931	694	833
4	160	81.5	555	56597	1124	1349
3	160	101.8	693	70694	1404	1685
2	160	110.3	548	62044	1232	1479

From the calculations above the following beams, columns, and connections were selected:

Floor	Columns		Girders				Connections	
	Shape	$I$	Shape	$I_{Lb}$	$I_n$	$I_{eq}$	Rein.	$K-ser$
R	W14x53	541	W16x31	972	526	794	6 #4	44195
4	W14x53	541	W16x31	972	609	827	10 #4	72980
3	W14x68	723	W18x40	1530	899	1278	10 #4	80278
2	W14x68	723	W18x40	1530	899	1278	10 #4	80278

After the member and connection selection the interstory drifts were calculated for these frames by both the approximate interstory drift equation (Equation A-1, Appendix A) and a linear elastic frame program with linear springs as partially restrained connections. A difference of less than 15

percent was found, with the approximate equation being conservative. The results are as follows:

Level	Interstory Drift (in.)				
	Interstory Equation	Fixed Base		PR Base	
		Analy.	% Diff.	Analy.	% Diff.
4-R	0.422	0.3660	15.3	0.3660	15.3
3-4	0.576	0.5330	8.1	0.5390	6.9
2-3	0.612	0.5480	11.7	0.5770	6.1
1-2	0.524	0.3590	46.0	0.5260	-0.4

### F. Step 6. Connection Details

In Step 6 the bottom angle, bolts, web angles, and connection reinforcement are chosen. In addition, the need for column stiffeners is evaluated and points on the moment-rotation curves are calculated in case a nonlinear connection model is to be used. The bottom angles (A36) and bolt sets for the E-W unbraced frames were selected based on the results of Step 5 and are listed below.

The seat angles and bolts were selected and checked with the aid of Table 8, Part IV. The negative and positive forces shown correspond to the governing criteria for the design of the top and bottom portion of the connection. The checks here include bolt shear, angle yielding, web crippling, web yielding, and need for stiffeners.

Level	Angle (k)	AL (in. <sup>2</sup> )	Negative Force (k)	Positive Force (k)	Bolts
R	L6x4x <sup>5</sup> / <sub>16</sub> x8	2.5	90	30.4	4- <sup>7</sup> / <sub>8</sub> -in. A325N
4	L6x4x <sup>1</sup> / <sub>2</sub> x8	4	144	48.6	4-1-in. A490N
3	L6x4x <sup>7</sup> / <sub>16</sub> x7.5	3.281	118	39.9	4-1-in. A325N
2	L6x4x <sup>7</sup> / <sub>16</sub> x7.5	3.281	118	39.9	4-1-in. A325N

The web angles and bolts were selected based on a capacity design approach. The governing shears are given as  $V-grav$  for the shear due  $1.3D + 0.5L$  and  $V-lat$  for the shear due to  $E$ . The  $\phi R_n$  values are taken from the Manual (AISC Table 9-2). The  $M_{n,conn}$  shown is the nominal connection strength taken from Table 1, Part IV.

Level (frame)	$V-grav$ (k)	$M_{n,conn}$ (k-ft)	$V-lat$ (k)	$V_u$ (k)	Web Angle	$\phi R_n$ (k)	$A_w$ (in. <sup>2</sup> )	$A_w > A_l$ (Y, N)
(Int)								
R	31.5	154	12.9	44.4	L4x4x <sup>1</sup> / <sub>4</sub> x8.5	71.8	4.25	Y
4	30.3	255	21.2	51.5	L4x4x <sup>1</sup> / <sub>4</sub> x8.5	66.7	4.25	Y
3	30.3	226	18.8	49.1	L4x4x <sup>1</sup> / <sub>4</sub> x8.5	66.7	4.25	Y
2	30.3	226	18.8	49.1	L4x4x <sup>1</sup> / <sub>4</sub> x8.5	66.7	4.25	Y
(Ext)								
R	18.6	154	12.9	31.5	L4x4x <sup>1</sup> / <sub>4</sub> x8.5	71.8	4.25	Y
4	28.8	255	21.2	50.0	L4x4x <sup>1</sup> / <sub>4</sub> x8.5	66.7	4.25	Y
3	28.8	226	18.8	47.6	L4x4x <sup>1</sup> / <sub>4</sub> x8.5	66.7	4.25	Y
2	28.8	226	18.8	47.6	L4x4x <sup>1</sup> / <sub>4</sub> x8.5	66.7	4.25	Y

The column stiffener checks have been carried out per Section

6.2 of the design procedure outlined in Part II. The following tables contain the values used in these calculations.  $P_u$  is the point load on the beam due to  $1.2DL_A + 1.6LL$  and the critical case is from interior connections.

Level	Beam	$P_u$ (k)	$l_{eq}$ (in.)	$\phi M_n, conn$ (k-ft)	$M(FE)$ (k-ft)	$1/(1+a)$	$M(SR)$ (k-ft)	Angle Force (k)
R	W16x31	33.4	794	130.4	178.1	0.54	95.3	57.5
4	W16x31	27.1	827	215.3	144.5	0.65	93.4	56.4
3	W18x35	27.1	1076	189.1	144.5	0.55	79.8	44.1
2	W18x35	27.1	1076	189.1	144.5	0.55	79.8	44.1

To determine the need for stiffeners, three types of loads were considered: Type 1 is a single compression force =  $A_c F_y$ ; Type 2 is a single tension force =  $0.3375 A_c F_y$ ; and Type 3 is compression on both sides. All of these come from the  $1.2DL_A + 1.6LL$  load case.

Level	Force Type		
	1	2	3
R	90	30.4	57.5
4	144	48.6	56.4
3	118.1	39.9	44.1
2	118.1	39.9	44.1

Input Data for Column Stiffener Checks:

Level	Column Size	$d$ (in.)	$t_w$ (in.)	$t_f$ (in.)	$h$ (in.)	$k$ (in.)	$N$ (in.)
R	14x61	13.89	0.375	0.645	11	1.44	0.8125
4	14x61	13.89	0.375	0.645	11	1.44	1
3	14x82	14.31	0.51	0.855	11	1.625	1
2	14x82	14.31	0.51	0.855	11	1.625	1

Ratios of Resistance Provided/Resistance Required (values  $> 1.0$  are **o.k.**):

$\phi R_n / R_u$				
Local Flange Buckling (K1-1)	Local Web Yielding (K1-2)	Web Crippling (K1-4)	Compression Buck. of Web (K1-8)	Panel-Zone Web Shear (K1-9)
Force Type 2	Type 1	Type 1	Type 3	Type 1
3.85	1.67	1.58	2.17	2.60
2.41	1.07	1.00	2.22	1.63
5.15	1.97	2.24	7.13	2.78
5.15	1.97	2.24	7.13	2.78

None of the columns required stiffeners.

Connection Summary:

Connection Strength by Ultimate Strength Equations (Equations 6 and 7 from Part I):

Level	$A_s$ (in. <sup>2</sup> )	$Y_3$ (in.)	Girder Depth (in.)	$A_l$ (in. <sup>2</sup> )	$A_w$ (in. <sup>2</sup> )	$\phi M_n(-)$ (k-ft)	$\phi M_n(+)$ (k-ft)
R	1.2	4	15.88	2.5	4.25	130.4	99.0
4	2	4	15.88	4	4.25	215.3	122.1
3	1.6	4	17.7	3.281	4.25	189.1	122.3
2	1.6	4	17.7	3.281	4.25	189.1	122.3

Moment-Rotation Curves: The negative bending moment-rotation relationships were calculated by Equation 1, Part I. The negative bending values at 1, 2.5, and 20 milliradians were used to define the trilinear moment-rotation relationship of the PR-CC's for use in the advanced analysis.

Rotation (mrad)	Nominal Moment (k-in.)	(k-ft)	Secant Stiffness (k-in./rad)	(k-ft/rad)
0	0.0	0.0		
1	738.5	61.5	738450	61538
2.5	1202.9	100.1	481156	40096
5	1448.5	120.7	289709	24142
10	1644.2	137.0	164418	13701
20	1982.9	165.2	99145	8262

Level: R; Beam: W16x31; Connection 6 #4  
 $C_1 = 1306.6$ ;  $C_2 = 0.775$ ;  $C_3 = 33.8$

Rotation (mrad)	Nominal Moment (k-in.)	(k-ft)	Secant Stiffness (k-in./rad)	(k-ft/rad)
0	0.0	0.0		
1	1205.8	100.5	1205798	100483
2.5	1951.5	162.6	780598	65050
5	2321.1	193.4	464215	38685
10	2571.6	214.3	257161	21430
20	2985.8	248.8	149292	12441

Level: 4; Beam: W16x31; Connection 10 #4  
 $C_1 = 2159.2$ ;  $C_2 = 0.775$ ;  $C_3 = 41.3$

Rotation (mrad)	Nominal Moment (k-in.)	(k-ft)	Secant Stiffness (k-in./rad)	(k-ft/rad)
0	0.0	0.0		
1	1063.3	88.6	1063305	88609
2.5	1725.2	143.8	690082	57507
5	2061.9	171.8	412374	34364
10	2306.3	192.2	230630	19219
20	2718.9	226.6	135947	11329

Level: 2&3; Beam: W18x35; Connection 8 #4  
 $C_1 = 1895.3$ ;  $C_2 = 0.775$ ;  $C_3 = 41.2$

### G. Step 7. Ultimate Strength Check of Beams and Frames

Plastic analysis is used to check the adequacy of the beams and frames at ultimate load level. The approximate second order analysis and sway parameters presented in Part I were

used to determine the failure load factor ( $\lambda_p$ ) of the interior and exterior E-W frames. The interior and exterior frames have the same members and connections and the equivalent lateral loads, but the gravity loads are different. The interstory drifts used to calculate second order effects are those from Step 5. The column plastic capacities have been reduced for axial loads as per Equation 18, Part I. The resulting failure load factor by this method is 1.42 for the interior frames and 2.31 for the exterior frames, both of which define adequacy by plastic analysis.

Reduced Base Column Plastic Capacities:

Column	$P_u$ (k)	Column Shape	$P_y$ (k)	$P_u/P_y$	$\Phi M_n$ (k-ft)	$\Phi M_{r-f}$ (k-ft)	% of $\Phi M_n$
Int	383	W14x82	1259	0.30	577	473.7	0.82
Int-Cor	356	W14x82	1259	0.28	577	488.3	0.85
Ext, Ln.A	228	W14x82	1259	0.18	577	557.6	0.97
Weighted Ave = 495.6							

First and Second-Order Rigid Plastic Load Factors

Level	$h_i$ (ft)	(k)	$\Phi M_n(-)$ Connection (k-ft)	$\Phi M_n(+)$ Connection (k-ft)	$\Phi M_{r-f}$ Column (k-ft)	Story Axial Ld. (k)	Story Drift (in.)
R	53.3	48.6	130.4	99	—	749	0.366
4	40.0	29.6	215.3	122.1	—	1345	0.539
3	26.7	19.0	189.1	122.3	—	1926	0.577
2	13.3	7.9	189.1	122.3	495.6	2464	0.526

Level	Sum $\Phi M_n$ (k-ft)	Sum $V_{i-h}$ (k-ft)	Sum $P-\Delta$ (k-ft)
R	1835	2593	23
4	2699	1182	60
3	2491	506	93
2	6952	105	108
SUM Sum $M_n$	13977 16152	4386	284
$\lambda-p$ , 1st order, 3.19 $\lambda-f$ , 2nd order, 1.42 $S_p=9.9$			

The  $S_p$  value is the result of interpolation from Table 6, Part IV. Similar calculations for the exterior frames resulted in  $\lambda-p = 3.72$  and  $\lambda-f = 2.31$

The beam ultimate capacities were also checked by plastic analysis:

Level	Girder	Connect.	$\Phi M_n(-)$ (k-ft)	$\Phi M_n(+)$ (k-ft)	Exterior Frames		Interior Frames	
					$P_u$	$\lambda-b$	$P_u$	$\lambda-b$
R	W16x31	6 #4	130.4	370	24.92	2.51	46.8	1.34
4	W16x31	10 #4	215.3	370	34.8	2.10	40.56	1.36
3	W18x35	8 #4	189.1	451	34.8	2.30	40.56	1.58
2	W18x35	8 #4	189.1	451	34.8	2.30	40.56	1.58

## H. Step 8. Interaction Checks:

A linear elastic frame analysis program with linear springs was used to determine the unbalanced and lateral moments in the frame. For the unbalanced moments four live load patterns were considered. The unbalanced moment was also calculated for the dead load after the hardening of the concrete ( $DL_A$ ), and only the exterior connections produced considerable unbalanced moments due to this load. The unbalanced moment due to the PR-CC's at roof level in the N-S direction was also calculated. These moments are on the weak-axis of the columns. The results of this analysis are shown in Figure E-9.

When determining the  $K$  factor by LRFD the effective girder moment of inertias were used ( $I_{eff}$ ). Two load combinations were considered; gravity load ( $1.2D + 1.6L$ ) and lateral load ( $1.3D + 0.5L + 1.0E$ ). The effective girder moment of inertial for the lateral load case of one connection loaded and one unloaded was used to determine the  $K$  factor values for both the gravity and lateral load combinations. The connection at the exterior column (Ext. Line A) was considered to be loaded with negligible stiffness, making it a leaner column with the  $K$  factor equal to one. The results of the interaction equations are tabulated below for the interior columns:

Level	Ld case	Gtop	Gbot	Kx		B1	$P_u / P_n$	Interaction
				value	controls?			
*4-R	1	4.22	7.16	2.32	No	1.00	0.31	0.86
	3	4.22	7.16	2.32	No	1.00	0.23	0.61
3-4	1	7.16	7.23	2.60	Yes	1.00	0.52	0.61
	3	7.16	7.23	2.60	Yes	1.00	0.40	0.59
2-3	1	7.23	8.38	2.69	Yes	1.04	0.53	0.59
	3	7.23	8.38	2.69	Yes	1.03	0.42	0.58
1-2	1	8.38	1.00	1.85	No	1.00	0.63	0.68
	3	8.38	1.00	1.86	No	1.00	0.51	0.68

Typical result for all members are shown below:

Level	Typical Interior	Interior Corner	Exterior Line A
4-R	0.86	0.77	0.21
3-4	0.61	0.55	0.37
2-3	0.59	0.55	0.37
1-2	0.68	0.65	0.43

Note that stability should be checked by a more advanced method that includes the concept of summation of story forces (See Reference [31], Part I).

### I. Step 9. Compatibility Check by Beam Line Analysis:

This step is used to establish compatibility of the moment-rotation relationship of the connection and the end rotation of the beam at service gravity loads. Beam line analysis was performed with  $M1$  values (connection moment at 2.5 milliradians) from Table 2, Part IV. The results, shown below, indicate that the all rotations are less than the 2.5 milliradians assumed, with an average rotation of 1.47 milliradians. Therefore, compatibility is satisfied and the service deflection checks (in the form of required lower bound moment of inertias) that assumed a rotation of 2.5 milliradians in Step 4 are valid.

Exterior Frame:

Input					Calc. Values		Beam	Line
Level	(ft)	$I_{eq}$ (in. <sup>4</sup> )	P (k)	$M1$ (k-ft)	$M_{ff}$ (k-ft)	$\theta(ss)$ (mrad)	$\theta$ (mrad)	M (actual) (k-ft)
R	24	794	12.1	96.4	64.5	4.84	1.24	48.0
4	24	827	19.8	159	105.6	7.61	1.36	86.7
2 & 3	24	1076	19.8	141	105.6	5.85	1.42	80.0

Interior Frame:

Input					Calc. Values		Beam	Line
Level	L (ft)	$I_{eq}$ (in. <sup>4</sup> )	P (k)	$M1$ (k-ft)	$M_{ff}$ (k-ft)	$\theta(ss)$ (mrad)	$\theta$ (mrad)	M (actual) (k-ft)
R	24	794	22.6	96.4	120.5	9.05	2.32	89.6
4	24	827	18.9	159	100.8	7.26	1.30	82.7
2 & 3	24	1076	18.9	141	100.8	5.58	1.35	76.4

## ADVANCED ANALYSIS

To check the accuracy of the design steps and the simplifications that have been made, an advanced analysis has been carried out on the E-W interior frame. To compare these results with those from the design steps the differences in the two analysis must be considered. For each comparison given there will be a discussion on the differences in the analysis that must be accounted for. The program used for the analysis

is a second order elasto-plastic analysis with connections that have tri-linear moment rotation curves. The moment rotation curves are for one direction only, therefore the negative bending moment rotation curves are used (negative bending at the connection is when the reinforcement is in tension). Since gravity loading puts all the connections in negative bending, using only the negative moment rotation curve is reasonable.

### Load Drift Behavior

The frame loading is carried out in a two step fashion. First the gravity load is applied in one step. Secondly, the frame is laterally loaded in a step by step progression from zero load to collapse of the structure. The final load reached is referred to as the failure load, and this value over the design lateral load is the failure load factor,  $\lambda_f$ . Therefore, the loading for this frame may be expressed as  $(1.3D + 0.5L + \lambda \times E)$  where  $\lambda$  is the load factor that increases from zero to  $\lambda_f$ . The design load for this frame is reached when  $\lambda$  equals 1.0. The full load deflection behavior of the frame is shown in Figure E-8. The drift recorded is that of the top story, and the drift factor is defined as the total drift over the allowable drift,  $0.00363h$ , where  $h$  is the height of the top story.

### Moments, Rotations, And Drift At The Design Load

Next the moments, rotations, and interstory drifts that correspond to the design load case,  $1.3D + 0.5L + 1.0E$  will be examined. The moments and rotations for the E-W interior frame may be found in Figure E-9. It should be noted that these values should not be directly compared to those in Figure E-7. Figure E-7 includes lateral loads only and the base column connections are considered as partially restrained. In the advanced analysis there are both gravity and lateral loads and the base columns are fixed. The maximum connection moments in both the positive and negative direction and the design strengths for each connection type have been tabulated below. In can be seen that all the moments are below the design values.

Level	Connect.	Connection Moment (k-ft)			
		Negative Moment		Positive Moment	
		$M_n(max)$	$\theta M_n(-)$	$M_n(max)$	$\theta M_n(+)$
R	6 #4	96.6	130.4	N/A	99
4	10 #4	124.8	215.3	N/A	122.1
2 & 3	8 #4	139.5	189.1	25.4	122.3

Note:  
N/A indicates that there were no positive moments in these connections.

Next, the connection rotations will be examined. The rotations for the frame may be found in Figure E-9. It can be seen that the majority of the rotations under the factored lateral load case are in the negative direction, due to gravity loading. The connections that continue to rotate in the same direction



as caused by gravity loads when the lateral loads are applied are referred to as the loaded connection. The ones that rotate in the opposite direction are the unloaded connections. The average rotation for the loaded connections throughout the frame is  $-2.24$  milliradians, and for the unloaded connections is  $-0.16$ . Note that the average unloaded connection is still a negative rotation.

It should also be noted that these values are based on live loads that have been reduced for the tributary area of the inframing beams only. When considering the entire frame, it

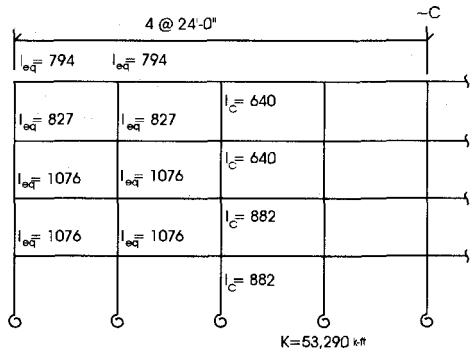

COMPUTER MODEL

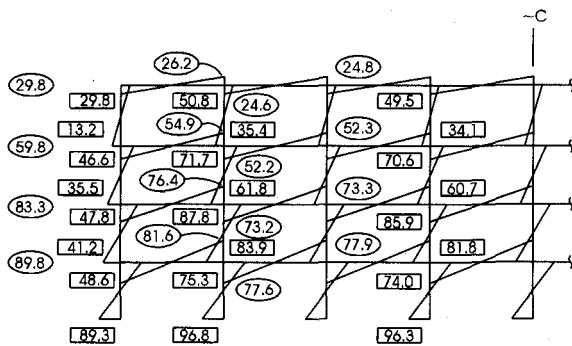

RESULTS : SEISMIC LOADS

□ = COLUMN MOMENTS, K-FT  
○ = BEAM MOMENTS, K-FT

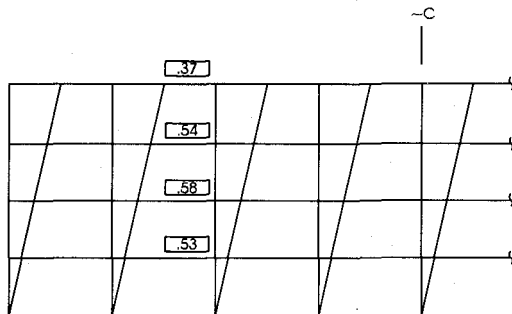

INTERSTORY DRIFT, INCHES

Figure E-7.

is more realistic to reduce the live loads based on the tributary area of multi-levels. This additional load along with the additional  $P-\Delta$  effects affect the forces, rotations, and drift of the frame. In light of the method for live load reduction, when the large stiffnesses of the unloaded connections are averaged with the loaded connection stiffnesses it is clear that the use of 2 milliradians for the lateral stiffness in Table 1 is indeed conservative in this case.

In the following table the interstory drifts are compared to the values calculated in Step 5 using linear springs and a fixed base. The  $P-\Delta$  effects are larger in this analysis due to an increase in dead load from  $1.0D$  to  $1.3D$  and also the method of live load reduction as just discussed. Therefore, the increase in the interstory drifts in this analysis are to be expected.

Level	Interstory (in.)		
	Elastic w/springs	Advanced	% Difference
4-R	0.366	0.398	8.7
3-4	0.533	0.573	7.5
2-3	0.548	0.595	8.6
1-2	0.359	0.379	5.6

### Failure Load Factor

In Step 7 an approximate failure load factor was calculated to be 2.37 for the interior frames. The failure load factor calculated in this advanced analysis is 3.51, which is quite a bit larger than the approximate value. This can be attributed to several discrepancies in the modeling. In the analysis the connections can continue to rotate past the 20 milliradians at the same stiffness and never reach a moment plateau (a plastic hinge). It was found that the average connection rotations at failure were  $-27$  milliradians for the loaded connections and  $+18$  for the unloaded connections. Therefore the moments at

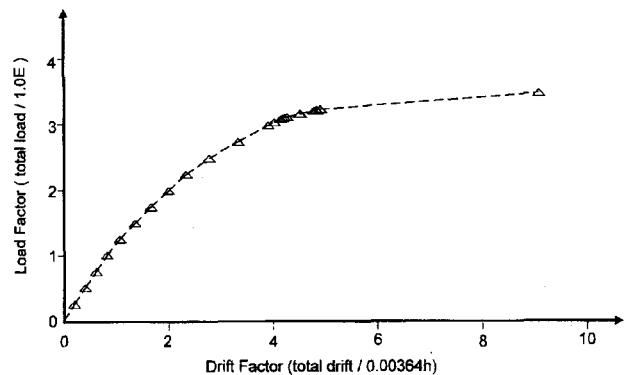
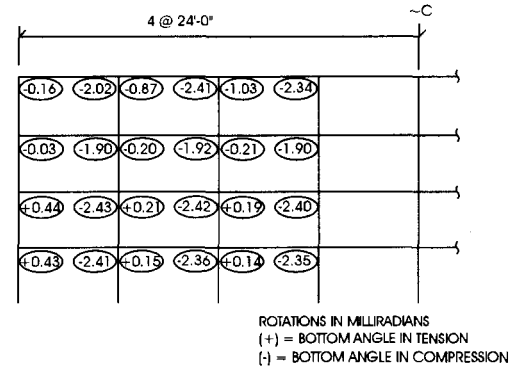

Figure E-8.

these connections correspond to larger moments than the design values used in Step 7. In addition to this, the nominal member strengths are used in the advanced analysis and design values are used in the calculation in Step 7. Furthermore, the use of connection moment rotation curves only in the negative direction contribute more to the frame over-

strength at failure than at design load levels, due to much more rotation in positive bending. With these things considered the difference between the failure load factors calculated by Step 7 and the advanced analysis is reasonable. The approximate failure load value in Step 7 is a conservative lower bound.



**CONNECTION ROTATIONS**

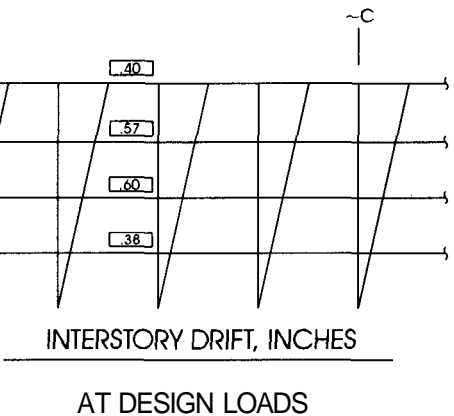
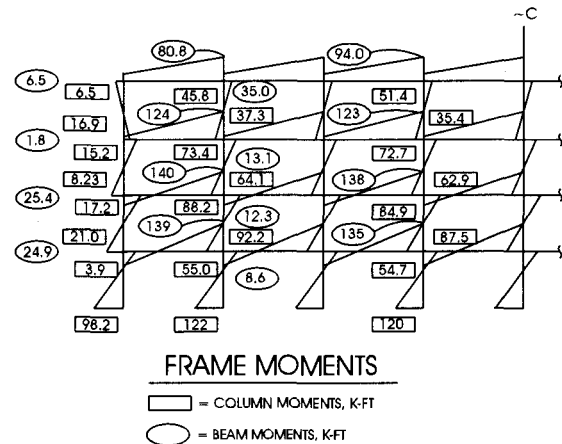

Figure E-9.

# Part IV

## TABLES AND DESIGN AIDS

**Table 1.**  
**Prequalified PR-CCs (Unbraced Frames— $F_y = 36$  ksi)**

Connection	Depth (in.)	Y3 = 3		Y3 = 4		Y3 = 5		Y3 = 6	
		$\phi M$ (k-ft)	$K-lat$ (k-ft/rad)	$\phi M$	$K-lat$ (k-ft/rad)	$\phi M$	$K-lat$ (k-ft/rad)	$\phi M$	$K-lat$ (k-ft/rad)
6 - #4 L6x4x5/16x6  $A_s$ (in. <sup>2</sup> ) = 1.2 $A_I$ (in. <sup>2</sup> ) = 1.875 Force ( $k$ ) = 68	12	92.5	33146	99	35356	105	37566	111	39775
	14	105	37566	111	39775	117	41985	123	44195
	16	117	41985	123	44195	130	46405	136	48614
	18	130	46405	136	48614	142	50824	148	53034
	21	148	53034	154	55243	160	57453	167	59663
	24	167	59663	173	61873	179	64082	185	66292
8 - #4 L6x4x5/16x7.5  $A_s$ (in. <sup>2</sup> ) = 1.6 $A_I$ (in. <sup>2</sup> ) = 2.34 Force ( $k$ ) = 84	12	122	44032	130	46968	138	49903	146	52839
	14	138	49903	146	52839	154	55774	163	58710
	16	154	55774	163	58710	171	61645	179	64581
	18	171	61645	179	64581	187	67516	195	70451
	21	195	70451	203	73387	211	76322	219	79258
	24	219	79258	228	82193	236	85129	244	88064
10 - #4 L6x4x3/8x8  $A_s$ (in. <sup>2</sup> ) = 2 $A_I$ (in. <sup>2</sup> ) = 3 Force ( $k$ ) = 108	12	153	54735	163	58384	173	62033	184	65682
	14	173	62033	184	65682	194	69331	204	72980
	16	194	69331	204	72980	214	76629	224	80278
	18	214	76629	224	80278	235	83927	245	87576
	21	245	87576	255	91225	265	94874	276	98524
	24	276	98524	286	102173	296	105822	306	109471
12 - #4 L6x4x1/2x7  $A_s$ (in. <sup>2</sup> ) = 2.4 $A_I$ (in. <sup>2</sup> ) = 3.5 Force ( $k$ ) = 126	12	183	66292	195	70712	207	75131	219	79551
	14	207	75131	219	79551	231	83970	244	88390
	16	231	83970	244	88390	256	92809	268	97229
	18	256	92809	268	97229	280	101648	292	106067
	21	292	106067	305	110487	317	114906	329	119326
	24	329	119326	341	123745	353	128165	365	132584
10 - #5 L8x4x9/16x8  $A_s$ (in. <sup>2</sup> ) = 3.07 $A_I$ (in. <sup>2</sup> ) = 4.5 Force ( $k$ ) = 162	12	234	84626	250	90268	265	95910	281	101552
	14	265	95910	281	101552	296	107193	312	112835
	16	296	107193	312	112835	328	118477	343	124119
	18	328	118477	343	124119	359	129760	374	135402
	21	374	135402	390	141044	406	146686	421	152327
	24	421	152327	437	157969	452	163611	468	169253

**NOTES:**

- 1) Y3 is the distance from the top of the beam flange to the centroid of the reinforcement.
- 2) The Force ( $k$ ) is the force in kips of the horizontal shear in the bottom angle =  $A_I \times F_y$ .
- 3)  $K-lat$  is the secant stiffness of the connection at 2 milliradians.
- 4) Bottom angles may require an 7- or 8-in. horizontal leg, depending on bolt spacing.

**Table 1.(cont.)  
Prequalified PR-CCs (Unbraced Frames—Fy = 50 ksi)**

Connection	Depth (in.)	Y3 = 3		Y3 = 4		Y3 = 5		Y3 = 6	
		$\phi M$ (k-ft)	K-lat (k-ft/rad)	$\phi M$	K-lat (k-ft/rad)	$\phi M$	K-lat (k-ft/rad)	$\phi M$	K-lat (k-ft/rad)
6 - #4 L6x4x5/16x6  As (in. <sup>2</sup> ) = 1.2 AI (in. <sup>2</sup> ) = 1.875 Force (k) = 94	12	99.4	33146	106	35356	113	37566	119	39775
	14	113	37566	119	39775	126	41985	132	44195
	16	126	41985	132	44195	139	46405	146	48614
	18	139	46405	146	48614	152	50824	159	53034
	21	159	53034	166	55243	172	57453	179	59663
	24	179	59663	185	61873	192	64082	199	66292
8 - #4 L6x4x5/16x7.5  As (in. <sup>2</sup> ) = 1.6 AI (in. <sup>2</sup> ) = 2.34 Force (k) = 117	12	130	44032	139	46968	148	49903	157	52839
	14	148	49903	157	52839	165	55774	174	58710
	16	165	55774	174	58710	183	61645	191	64581
	18	183	61645	191	64581	200	67516	209	70451
	21	209	70451	217	73387	226	76322	235	79258
	24	235	79258	244	82193	252	85129	261	88064
10 - #4 L6x4x3/8x8  As (in. <sup>2</sup> ) = 2 AI (in. <sup>2</sup> ) = 3 Force (k) = 150	12	164	54735	175	58384	186	62033	197	65682
	14	186	62033	197	65682	208	69331	219	72980
	16	208	69331	219	72980	230	76629	241	80278
	18	230	76629	241	80278	251	83927	262	87576
	21	262	87576	273	91225	284	94874	295	98524
	24	295	98524	306	102173	317	105822	328	109471
12 - #4 L6x4x1/2x7  As (in. <sup>2</sup> ) = 2.4 AI (in. <sup>2</sup> ) = 3.5 Force (k) = 175	12	195	66292	209	70712	222	75131	235	79551
	14	222	75131	235	79551	248	83970	261	88390
	16	248	83970	261	88390	274	92809	287	97229
	18	274	92809	287	97229	300	101648	313	106067
	21	313	106067	326	110487	339	114906	352	119326
	24	352	119326	365	123745	378	128165	391	132584
10 - #5 L8x4x9/16x8  As (in. <sup>2</sup> ) = 3.07 AI (in. <sup>2</sup> ) = 4.5 Force (k) = 225	12	250	84626	267	90268	284	95910	300	101552
	14	284	95910	300	101552	317	107193	334	112835
	16	317	107193	334	112835	351	118477	367	124119
	18	351	118477	367	124119	384	129760	401	135402
	21	401	135402	417	141044	434	146686	451	152327
	24	451	152327	467	157969	484	163611	501	169253

NOTES:

- 1) Y3 is the distance from the top of the beam flange to the centroid of the reinforcement.
- 2) The Force(k) is the force in kips of the horizontal shear in the bottom angle =  $A/x F_y$ .
- 3) K-lat is the secant stiffness of the connection at 2 milliradians.
- 4) Bottom angles may require an 7- or 8-in. horizontal leg, depending on bolt spacing.

**Table 1. (cont.)  
Prequalified PR-CCs (Braced Frames)**

Connection	Depth (in.)	$\phi M$ (kip-ft)							
		Design With Web Angles				Design Without Web Angles			
		Y3(in.)				Y3(in.)			
		3	4	5	6	3	4	5	6
6 - #4  As (in. <sup>2</sup> ) = 1.2 A1-36 (in. <sup>2</sup> ) = 2 A1-50 (in. <sup>2</sup> ) = 1.44 Force (k) = 72	12	93.7	100	106	112	77	82	87	92
	14	106	112	119	125	87	92	97	102
	16	119	125	131	137	97	102	107	112
	18	131	137	144	150	107	112	117	122
	21	150	156	162	169	122	128	133	138
24	169	175	181	187	138	143	148	153	
8 - #4  As (in. <sup>2</sup> ) = 1.6 A1-36 (in. <sup>2</sup> ) = 2.67 A1-50 (in. <sup>2</sup> ) = 1.92 Force (k) = 96	12	125	133	142	150	102	109	116	122
	14	142	150	158	167	116	122	129	136
	16	158	167	175	183	129	136	143	150
	18	175	183	192	200	143	150	156	163
	21	200	208	217	225	163	170	177	184
24	225	233	242	250	184	190	197	204	
10 - #4  As (in. <sup>2</sup> ) = 2 A1-36 (in. <sup>2</sup> ) = 3.33 A1-50 (in. <sup>2</sup> ) = 2.4 Force (k) = 120	12	156	167	177	187	128	136	145	153
	14	177	187	198	208	145	153	162	170
	16	198	208	219	229	162	170	179	187
	18	219	229	239	250	179	187	196	204
	21	250	260	271	281	204	213	221	230
24	281	292	302	312	230	238	247	255	
12 - #4  As (in. <sup>2</sup> ) = 2.4 A1-36 (in. <sup>2</sup> ) = 4 A1-50 (in. <sup>2</sup> ) = 2.88 Force (k) = 144	12	187	200	212	225	153	163	173	184
	14	212	225	237	250	173	184	194	204
	16	237	250	262	275	194	204	214	224
	18	262	275	287	300	214	224	235	245
	21	300	312	325	337	245	255	265	275
24	337	350	362	375	275	286	296	306	
10 - #5  As (in. <sup>2</sup> ) = 3.07 A1-36 (in. <sup>2</sup> ) = 5.12 A1-50 (in. <sup>2</sup> ) = 3.68 Force (k) = 184	12	240	256	272	288	196	209	222	235
	14	272	288	304	320	222	235	248	261
	16	304	320	336	352	248	261	274	287
	18	336	352	368	384	274	287	300	313
	21	384	400	416	432	313	326	339	352
24	432	448	464	479	352	365	378	391	

Notes:

- 1) Y3 is the distance from the top of the beam flange to the centroid of the reinforcement.
- 2) The Force (k) is the force in kips of the horizontal shear =  $Al \times F_y = As \times F_y r_b$ .
- 3) A1-36 and A1-50 are the areas of the bottom angle required using 36 and 50 ksi steel, respectively.
- 4) Bottom angles with areas greater than or equal to A1 are required. The angles in Table 5.6 are suggested for use.

**Table 21.**  
**PR-CCs and M2 Values— Y3= 3 in.**

Connection	Depth (in.)	Unbraced Frames				Braced Frames (36 or 50 ksi)		
		Fy(angle) = 36 ksi		Fy(angle) = 50 ksi		M1	M2	
		M1	M2	M1	M2		With Web	Without Web
6 - #4  As (in. <sup>2</sup> ) = 1.2 Al-Unb (36) = 2.5 Al-Unb (50) = 1.875 Al-Br (in. <sup>2</sup> ) = 2	12	72.3	114	73.0	116	68.9	98	91.3
	14	81.9	129	82.7	131	78.1	111	103
	16	91.6	144	92.5	147	87.3	124	116
	18	101	159	102	162	96	137	128
	21	116	182	117	185	110	156	146
	24	130	205	131	208	124	176	164
8 - #4  As (in. <sup>2</sup> ) = 1.6 Al-Unb (36) = 3.28 Al-Unb (50) = 2.34 Al-Br (in. <sup>2</sup> ) = 2.67	12	96	151	96	150	92	130	122
	14	109	171	109	170	104	147	138
	16	122	191	121	190	116	165	154
	18	134	211	134	210	129	182	170
	21	154	241	153	240	147	208	195
	24	173	271	173	270	165	234	219
10 - #4  As (in. <sup>2</sup> ) = 2 Al-Unb (36) = 4 Al-Unb (50) = 3 Al-Br (in. <sup>2</sup> ) = 3.33	12	119	186	120	189	115	163	152
	14	135	211	137	215	130	184	172
	16	151	236	153	240	146	206	193
	18	167	261	169	265	161	228	213
	21	191	298	193	303	184	260	243
	24	215	335	217	341	207	293	274
12 - #4  As (in. <sup>2</sup> ) = 2.4 Al-Unb (36) = 5 Al-Unb (50) = 3.5 Al-Br (in. <sup>2</sup> ) = 4	12	145	227	144	225	138	195	183
	14	164	258	163	255	156	221	207
	16	183	288	182	284	175	247	231
	18	202	318	201	314	193	273	256
	21	231	364	230	359	221	312	292
	24	260	409	259	404	248	351	329
10 - #5  As (in. <sup>2</sup> ) = 3.07 Al-Unb (36) = 6.13 Al-Unb (50) = 4.5 Al-Br (in. <sup>2</sup> ) = 5.12	12	183	285	184	288	176	250	234
	14	208	324	208	326	200	283	265
	16	232	362	233	365	223	316	296
	18	256	400	258	403	247	350	327
	21	293	457	294	461	282	399	374
	24	330	514	331	518	317	449	420

NOTES:

- 1) Y3 is the distance from the top of the beam flange to the centroid of the reinforcement.
- 2) M1 and M2 are the nominal connection strengths at 2.5 and 20 milliradians, respectively.
- 3) Al-Unb (36) and Al-Unb (50) are the areas of the bottom angle checked by capacity design (Table 5.5).
- 4) M2 is an approximate for the unbraced frame and braced frame with double web angles. A lower bound web angle area equal to Al is used for the unbraced value and 0.5Al for the braced value.

**Table 2.2.**  
**PR-CCs and M2 Values—Y3 = 4 in.**

Connection	Depth (in.)	Unbraced Frames				Braced Frames (36 or 50 ksi)		
		Fy(angle) = 36 ksi		Fy(angle) = 50 ksi		M1	M2	
		M1	M2	M1	M2		With Web	Without Web
6 - #4 <i>As</i> (in. <sup>2</sup> ) = 1.2 <i>Al-Unb</i> (36) = 2.5 <i>Al-Unb</i> (50) = 1.875 <i>Al-Br</i> (in. <sup>2</sup> ) = 2	12	77.1	121	77.9	123	73.5	104	97.4
	14	86.7	136	87.6	139	82.7	117	110
	16	96.4	152	97.3	154	91.9	130	122
	18	106	167	107	170	101	143	134
	21	120	189	122	193	115	163	152
24	135	212	136	216	129	182	170	
8 - #4 <i>As</i> (in. <sup>2</sup> ) = 1.6 <i>Al-Unb</i> (36) = 3.28 <i>Al-Unb</i> (50) = 2.34 <i>Al-Br</i> (in. <sup>2</sup> ) = 2.67	12	102	161	102	160	98	139	130
	14	115	181	115	180	110	156	146
	16	128	201	128	200	123	173	162
	18	141	221	141	220	135	191	179
	21	160	251	160	250	153	217	203
24	179	281	179	280	172	243	227	
10 - #4 <i>As</i> (in. <sup>2</sup> ) = 2 <i>Al-Unb</i> (36) = 4 <i>Al-Unb</i> (50) = 3 <i>Al-Br</i> (in. <sup>2</sup> ) = 3.33	12	127	199	129	202	123	173	162
	14	143	223	145	227	138	195	183
	16	159	248	161	253	153	217	203
	18	175	273	177	278	168	239	223
	21	199	310	201	316	191	271	254
24	223	348	225	354	214	304	284	
12 - #4 <i>As</i> (in. <sup>2</sup> ) = 2.4 <i>Al-Unb</i> (36) = 5 <i>Al-Unb</i> (50) = 3.5 <i>Al-Br</i> (in. <sup>2</sup> ) = 4	12	154	242	153	240	147	208	195
	14	173	273	172	270	165	234	219
	16	193	303	192	299	184	260	243
	18	212	333	211	329	202	286	268
	21	241	379	239	374	230	325	304
24	270	424	268	419	257	364	341	
10 - #5 <i>As</i> (in. <sup>2</sup> ) = 3.07 <i>Al-Unb</i> (36) = 6.13 <i>Al-Unb</i> (50) = 4.5 <i>Al-Br</i> (in. <sup>2</sup> ) = 5.12	12	195	305	196	307	188	266	249
	14	220	343	221	345	212	300	280
	16	244	381	245	384	235	333	311
	18	269	419	270	422	259	366	343
	21	305	476	307	480	294	416	389
24	342	533	343	537	329	466	436	

NOTES:

- 1) Y3 is the distance from the top of the beam flange to the centroid of the reinforcement.
- 2) M1 and M2 are the nominal connection strengths at 2.5 and 20 milliradians, respectively.
- 3) *Al-Unb* (36) and *Al-Unb* (50) are the areas of the bottom angle checked by capacity design (Table 5.5).
- 4) M2 is an approximate for the unbraced frame and braced frame with double web angles. A lower bound web angle area equal to *Al* is used for the unbraced value and  $\frac{6A}{4}$  for the braced value.

**Table 2.3.**  
**PR-CCs and M2 Values— Y3 = 5 in.**

Connection	Depth (in.)	Unbraced Frames				Braced Frames (36 or 50 ksi)		
		$F_y(\text{angle})= 36 \text{ ksi}$		$F_y(\text{angle})= 50 \text{ ksi}$		$M1$	$M2$	
		$M1$	$M2$	$M1$	$M2$		With Web	Without Web
6 - #4  $A_s (\text{in.}^2) = 1.2$ $AI-Unb (36) = 2.5$ $AI-Unb (50) = 1.875$ $AI-Br (\text{in.}^2) = 2$	12	81.9	129	82.7	131	78.1	111	103.5
	14	91.6	144	92.5	147	87.3	124	116
	16	101.2	159	102.2	162	96.5	137	128
	18	111	174	112	177	106	150	140
	21	125	197	127	201	119	169	158
24	140	220	141	224	133	189	176	
8 - #4  $A_s (\text{in.}^2) = 1.6$ $AI-Unb (36) = 3.28$ $AI-Unb (50) = 2.34$ $AI-Br (\text{in.}^2) = 2.67$	12	109	171	109	170	104	147	138
	14	122	191	121	190	116	165	154
	16	134	211	134	210	129	182	170
	18	147	231	147	230	141	200	187
	21	166	261	166	260	159	226	211
24	186	291	185	290	178	252	235	
10 - #4  $A_s (\text{in.}^2) = 2$ $AI-Unb (36) = 4$ $AI-Unb (50) = 3$ $AI-Br (\text{in.}^2) = 3.33$	12	135	211	137	215	130	184	172
	14	151	236	153	240	146	206	193
	16	167	261	169	265	161	228	213
	18	183	285	185	290	176	249	233
	21	207	323	209	328	199	282	264
24	231	360	233	366	222	314	294	
12 - #4  $A_s (\text{in.}^2) = 2.4$ $AI-Unb (36) = 5$ $AI-Unb (50) = 3.5$ $AI-Br (\text{in.}^2) = 4$	12	164	258	163	255	156	221	207
	14	183	288	182	284	175	247	231
	16	202	318	201	314	193	273	256
	18	222	349	220	344	211	299	280
	21	251	394	249	389	239	338	316
24	280	439	278	434	267	377	353	
10 - #5  $A_s (\text{in.}^2) = 3.07$ $AI-Unb (36) = 6.13$ $AI-Unb (50) = 4.5$ $AI-Br (\text{in.}^2) = 5.12$	12	208	324	208	326	200	283	265
	14	232	362	233	365	223	316	296
	16	256	400	258	403	247	350	327
	18	281	438	282	441	270	383	358
	21	317	495	319	499	306	433	405
24	354	552	356	557	341	483	452	

NOTES:

- 1) Y3 is the distance from the top of the beam flange to the centroid of the reinforcement.
- 2)  $M1$  and  $M2$  are the nominal connection strengths at 2.5 and 20 milliradians, respectively.
- 3)  $AI-Unb (36)$  and  $AI-Unb (50)$  are the areas of the bottom angle checked by capacity design (Table 5.5).
- 4)  $M2$  is an approximate for the unbraced frame and braced frame with double web angles. A lower bound web angle area equal to  $AI$  is used for the unbraced value and  $0.5AI$  for the braced value.



**Table 2.4.**  
**PR-CCs and M2 Values— Y3= 6 in.**

Connection	Depth (in.)	Unbraced Frames				Braced Frames (36 or 50 ks)		
		$F_y(\text{angle}) = 36 \text{ ksi}$		$F_y(\text{angle}) = 50 \text{ ksi}$		M1	M2	
		M1	M2	M1	M2		With Web	Without Web
6 - #4  As (in. <sup>2</sup> ) = 1.2 Al-Unb (36) = 2.5 Al-Unb (50) = 1.875 Al-Br (in. <sup>2</sup> ) = 2	12	86.7	136	87.6	139	82.7	117	109.5
	14	96.4	152	97.3	154	91.9	130	122
	16	106.0	167	107.0	170	101.1	143	134
	18	116	182	117	185	110	156	146
	21	130	205	131	208	124	176	164
24	145	227	146	231	138	195	183	
8 - #4  As (in. <sup>2</sup> ) = 1.6 Al-Unb (36) = 3.28 Al-Unb (50) = 2.34 Al-Br (in. <sup>2</sup> ) = 2.67	12	115	181	115	180	110	156	146
	14	128	201	128	200	123	173	162
	16	141	221	141	220	135	191	179
	18	154	241	153	240	147	208	195
	21	173	271	173	270	165	234	219
24	192	301	192	300	184	260	243	
10 - #4  As (in. <sup>2</sup> ) = 2 Al-Unb (36) = 4 Al-Unb (50) = 3 Al-Br (in. <sup>2</sup> ) = 3.33	12	143	223	145	227	138	195	183
	14	159	248	161	253	153	217	203
	16	175	273	177	278	168	239	223
	18	191	298	193	303	184	260	243
	21	215	335	217	341	207	293	274
24	239	372	241	379	230	325	304	
12 - #4  As (in. <sup>2</sup> ) = 2.4 Al-Unb (36) = 5 Al-Unb (50) = 3.5 Al-Br (in. <sup>2</sup> ) = 4	12	173	273	172	270	165	234	219
	14	193	303	192	299	184	260	243
	16	212	333	211	329	202	286	268
	18	231	364	230	359	221	312	292
	21	260	409	259	404	248	351	329
24	289	455	287	449	276	390	365	
10 - #5  As (in. <sup>2</sup> ) = 3.07 Al-Unb (36) = 6.13 Al-Unb (50) = 4.5 Al-Br (in. <sup>2</sup> ) = 5.12	12	220	343	221	345	212	300	280
	14	244	381	245	384	235	333	311
	16	269	419	270	422	259	366	343
	18	293	457	294	461	282	399	374
	21	330	514	331	518	317	449	420
24	366	571	368	576	353	499	467	

NOTES:

- 1) Y3 is the distance from the top of the beam flange to the centroid of the reinforcement.
- 2) M1 and M2 are the nominal connection strengths at 2.5 and 20 milliradians, respectively.
- 3) Al-Unb (36) and Al-Unb (50) are the areas of the bottom angle checked by capacity design (Table 5.5).
- 4) M2 is an approximate for the unbraced frame and braced frame with double web angles. A lower bound web angle area equal to Al/is used for the unbraced value and 0.5Al for the braced value.

**Table 3.  
Beam Line and Deflection Coefficients for Common Loading Patterns**

Load Cases						
	1	2	3	4	5	
	↓	↓ ↓	↓ ↓ ↓	↓ ↓ ↓ ↓	↓ ↓ ↓ ↓ ↓	w 
Load Case	Coefficients, $C_0$					
	$M_{ff}$	$M_{fp}$	$\theta_{ss}$	$\delta_{ff}$	$\delta_{fp}$	$\delta_{ss}$
1	$1/8$	$3/16$	$1/16$	$1/192$	0.01	$1/48$
2	$2/9$	$1/3$	$1/9$	$5/648$	0.02	$23/648$
3	$5/16$	$15/32$	$5/32$	$1/96$	0.02	$19/384$
4	$2/5$	$3/5$	$1/5$	$13/1000$	0.03	$63/1000$
5	$1/12$	$1/8$	$1/24$	$1/384$	$1/185$	$5/384$

Note: Spaces between point loads are equal for each beam.

The following three equations are used with the coefficient values in the table above to calculate beam values:

$$M_{ff}, M_{fp} = C_0(PL \text{ or } wL^2)$$

$$\theta_{ss} = \frac{C_0(PL^2 \text{ or } wL^3)}{EI}$$

$$\delta_{ff}, \delta_{fp}, \delta_{ss} = \frac{C_0(PL^3 \text{ or } wL^4)}{EI}$$

where

$M$  = the fixed end moment

$\theta$  = the beam end rotation

$\delta$  = the maximum beam deflection

$P$  and  $w$  = the point and distributed loads

$l$ ,  $E$ , and  $I$  = length, modulus of elasticity, and moment of inertia of the beam, respectively, and

$C_0$  = the coefficient for each case, listed in Table 2.2.

The subscripts  $ff$ ,  $fp$ , and  $ss$  denote the type of beam end conditions: both ends fixed ( $ff$ ), one end fixed and one pinned ( $fp$ ), and both ends pinned ( $ss$ , simply supported).

**Table 4.  
Collapse Mechanism Coefficients for Beams**

Load Cases												
<div style="display: flex; justify-content: space-around; align-items: center;"> <div style="text-align: center;">1 ↓</div> <div style="text-align: center;">2 ↓ ↓</div> <div style="text-align: center;">3 ↓ ↓ ↓</div> <div style="text-align: center;">4 ↓ ↓ ↓ ↓</div> <div style="text-align: center;">5 w </div> </div>												
Note: Spaces between point loads are equal for each beam.												
Load Case	Connection Relationship											
	$M_{p,c1} = M_{p,c2}$				$M_{p,c1} > M_{p,c2}$				$M_{p,c2} = 0$			
	a	b	c	d	a	b	c	d	a	b	c	d
1	1	0	1	4	1	1	2	2	1	0	2	2
2	1	0	1	3	1	2	3	1	1	0	3	1
3	1	0	1	2	1	1	2	1	1	0	2	1
4	1	0	1	$\frac{5}{3}$	2	3	5	$\frac{5}{12}$	2	0	5	$\frac{5}{12}$
5	1	0	1	8					1	0	$\frac{L}{x}$	$\frac{2L}{L-x}$

$$x = \frac{M_{p,b}}{M_{p,c1}} L \left( \sqrt{1 + \frac{M_{p,c1}}{M_{p,b}}} - 1 \right)$$

Table 5. Values of $S_p$ for different frame geometries			
No. of Stories	Story Height (ft)		
	12	14	16
4	4.85	4.40	3.10
6	3.70	2.95	2.55
8	2.45	1.95	1.35

Table 6. C-θ									
Kb/Ka	1/(1 + α)								
	0.9	0.8	0.7	0.6	0.5	0.4	0.3	0.2	0.1
1	1	1	1	1	1	1	1	1	1
0.9	1.05	1.04	1.04	1.03	1.03	1.02	1.02	1.01	1.01
0.8	1.11	1.09	1.08	1.07	1.05	1.04	1.03	1.02	1.01
0.7	1.18	1.15	1.13	1.11	1.09	1.07	1.05	1.03	1.02
0.6	1.27	1.22	1.18	1.15	1.12	1.09	1.07	1.04	1.02
0.5	1.39	1.31	1.25	1.20	1.16	1.12	1.08	1.05	1.03
0.4	1.54	1.41	1.32	1.25	1.20	1.15	1.10	1.07	1.03
0.3	1.76	1.55	1.41	1.32	1.24	1.18	1.12	1.08	1.04
0.2	2.09	1.72	1.52	1.39	1.29	1.21	1.15	1.09	1.04
0.1	2.63	1.97	1.66	1.47	1.34	1.25	1.17	1.10	1.05
0.0	3.70	2.32	1.83	1.57	1.40	1.28	1.19	1.12	1.05

Symbols:  
 Kb = Stiffness of the less stiff connection  
 Ka = Stiffness of the stiffer connection  
 $1/(1 + \alpha) = M(PR)/M(\text{fix-fix})$   
 $\alpha = 2EI/(KaL)$

**Table 7a.**  
**Negative Bending Moments of Inertia (W12 and W14)**

12-in. Beams		Y3=3in.					Y3=4in.				
Reinforcing Bars Area of Reinf., In. <sup>2</sup>		6-#4 1.2	8-#4 1.6	10-#4 2.0	12-#4 2.4	10-#5 3.1	6-#4 1.2	8-#4 1.6	10-#4 2.0	12-#4 2.4	10-#5 3.1
Wt of stl	Is	In	In	In	In	In	In	In	In	In	In
14	88.6	163	181	197	211	230	181	203	222	239	264
16	103	180	200	217	232	253	199	222	243	262	289
19	130	211	232	251	268	293	230	256	280	300	331
22	156	241	264	284	303	331	260	288	314	337	371
26	204	290	314	336	356	386	310	339	366	391	428
30	238	327	352	375	397	429	347	378	407	433	473
35	285	377	403	428	452	487	398	430	461	489	533
40	310	398	423	448	470	506	418	450	480	508	552
45	350	440	466	492	516	553	461	494	525	554	601
50	394	486	513	540	565	604	507	541	573	604	653
53	425	516	543	570	595	634	537	571	603	634	683
58	475	568	596	623	649	690	589	624	657	689	740
65	533	626	654	682	708	750	647	682	716	749	801
72	597	692	721	749	776	820	713	749	784	818	872

14-in. Beams		Y3=3in.					Y3=4in.				
Reinforcing Bars Area of Reinf., In. <sup>2</sup>		6-#4 1.2	8-#4 1.6	10-#4 2.0	12-#4 2.4	10-#5 3.1	6-#4 1.2	8-#4 1.6	10-#4 2.0	12-#4 2.4	10-#5 3.1
Wt of stl	Is	In	In	In	In	In	In	In	In	In	In
22	199	298	324	348	370	402	319	351	380	406	445
26	245	348	376	402	426	462	370	404	435	465	508
30	291	395	424	452	477	515	417	453	486	516	563
34	340	447	478	506	533	574	469	507	541	574	624
38	385	494	526	556	585	628	517	556	592	626	679
43	428	534	565	595	623	667	557	595	630	664	718
48	485	593	626	656	686	732	616	656	693	728	784
53	541	652	685	717	747	795	675	715	754	791	849
61	640	751	785	818	849	899	775	816	856	894	954
68	723	837	872	906	938	990	860	903	944	983	1046
74	796	912	948	982	1016	1070	936	979	1021	1062	1127
82	882	1000	1037	1072	1107	1163	1024	1069	1112	1154	1221
90	999	1114	1150	1185	1220	1275	1138	1182	1224	1266	1333
99	1110	1227	1264	1300	1335	1392	1251	1296	1340	1382	1451

**Table 7a. (cont.)  
Negative Bending Moments of Inertia (W12 and W14)**

12-in. Beams		Y3=5in.					Y3=6in.				
Reinforcing Bars Area of Reinf., In. <sup>2</sup>		6-#4 1.2	8-#4 1.6	10-#4 2.0	12-#4 2.4	10-#5 3.1	6-#4 1.2	8-#4 1.6	10-#4 2.0	12-#4 2.4	10-#5 3.1
Wt of stl	Is	In	In	In	In	In	In	In	In	In	In
14	88.6	200	227	251	271	301	222	254	282	306	341
16	103	219	247	273	295	328	241	275	305	332	370
19	130	251	283	311	336	373	274	311	345	375	419
22	156	282	316	346	374	415	306	346	382	415	464
26	204	332	367	400	429	474	356	398	437	472	525
30	238	370	407	441	473	522	394	438	479	517	575
35	285	421	460	497	531	584	446	493	536	577	640
40	310	441	480	516	550	603	466	512	555	596	659
45	350	484	524	561	597	653	509	557	601	644	710
50	394	531	572	611	648	707	556	605	652	696	766
53	425	561	602	641	678	737	586	635	682	726	796
58	475	613	655	695	734	795	639	689	737	783	855
65	533	671	714	754	794	857	697	748	796	843	918
72	597	738	781	823	864	929	764	816	866	914	991

14-in. Beams		Y3=5in.					Y3=6in.				
Reinforcing Bars Area of Reinf., In. <sup>2</sup>		6-#4 1.2	8-#4 1.6	10-#4 2.0	12-#4 2.4	10-#5 3.1	6-#4 1.2	8-#4 1.6	10-#4 2.0	12-#4 2.4	10-#5 3.1
Wt of stl	Is	In	In	In	In	In	In	In	In	In	In
22	199	342	380	414	446	493	367	412	452	489	544
26	245	393	434	472	506	559	419	467	511	552	613
30	291	441	484	523	559	615	467	517	563	606	671
34	340	494	538	580	618	678	521	573	621	667	736
38	385	542	588	631	672	735	570	623	674	722	795
43	428	581	627	670	710	773	608	662	712	760	834
48	485	641	688	733	775	842	669	724	776	826	904
53	541	700	749	795	839	908	728	785	839	890	972
61	640	800	850	897	942	1014	828	886	941	995	1079
68	723	887	937	986	1033	1108	915	974	1031	1086	1174
74	796	962	1014	1064	1112	1189	991	1051	1110	1166	1257
82	882	1051	1104	1155	1204	1284	1080	1142	1202	1260	1353
90	999	1165	1217	1267	1316	1396	1193	1254	1314	1371	1465
99	1110	1278	1331	1383	1434	1515	1307	1369	1430	1489	1585

**Table 7b.**  
**Negative Bending Moments of Inertia (W16 and W18)**

16-in. Beams		Y3=3in.					Y3=4in.				
Reinforcing Bars Area of Reinf., In. <sup>2</sup>		6-#4 1.2	8-#4 1.6	10-#4 2.0	12-#4 2.4	10-#5 3.1	6-#4 1.2	8-#4 1.6	10-#4 2.0	12-#4 2.4	10-#5 3.1
Wt of stl	Is	In	In	In	In	In	In	In	In	In	In
26	301	423	457	488	516	559	447	487	524	558	609
31	375	502	538	571	602	650	526	569	609	646	702
36	448	577	614	649	682	732	601	646	687	727	787
40	518	650	689	725	760	813	675	721	764	805	869
45	586	721	761	799	835	891	746	794	839	882	949
50	659	796	838	877	915	974	822	871	918	963	1033
57	758	899	942	983	1022	1084	925	976	1025	1071	1145
67	954	1095	1138	1180	1221	1285	1121	1173	1223	1271	1347
77	1110	1254	1299	1343	1385	1453	1281	1335	1386	1436	1516
89	1300	1448	1495	1540	1584	1656	1476	1531	1585	1637	1721
100	1490	1642	1690	1737	1783	1857	1670	1727	1782	1836	1923

18-in. Beams		Y3=3in.					Y3=4in.				
Reinforcing Bars Area of Reinf., In. <sup>2</sup>		6-#4 1.2	8-#4 1.6	10-#4 2.0	12-#4 2.4	10-#5 3.1	6-#4 1.2	8-#4 1.6	10-#4 2.0	12-#4 2.4	10-#5 3.1
Wt of stl	Is	In	In	In	In	In	In	In	In	In	In
35	510	661	704	745	783	842	687	739	787	831	901
40	612	768	813	856	897	960	795	848	899	946	1021
46	712	871	919	964	1007	1074	899	955	1008	1058	1137
50	800	960	1008	1053	1097	1165	987	1044	1097	1148	1229
55	890	1052	1102	1149	1194	1265	1080	1138	1193	1246	1330
60	984	1149	1199	1248	1294	1368	1177	1236	1293	1348	1434
65	1070	1237	1289	1338	1386	1462	1266	1326	1384	1440	1529
71	1170	1340	1392	1443	1492	1570	1369	1430	1490	1547	1639
76	1330	1497	1549	1599	1648	1725	1526	1586	1645	1702	1793
86	1530	1700	1754	1806	1856	1937	1729	1792	1853	1912	2007
97	1750	1924	1979	2033	2085	2169	1954	2018	2080	2141	2240
106	1910	2087	2143	2197	2251	2337	2116	2182	2246	2308	2409
119	2190	2371	2429	2485	2540	2630	2401	2468	2534	2598	2703
130	2460	2645	2705	2763	2820	2913	2676	2745	2813	2879	2988

**Table 7b. (cont.)  
Negative Bending Moments of Inertia (W16 and W18)**

16-in. Beams		Y3 = 5 in.					Y3 = 6 in.				
Reinforcing Bars Area of Reinf., In. <sup>2</sup>		6-#4 1.2	8-#4 1.6	10-#4 2.0	12-#4 2.4	10-#5 3.1	6-#4 1.2	8-#4 1.6	10-#4 2.0	12-#4 2.4	10-#5 3.1
Wt of stl	Is	In	In	In	In	In	In	In	In	In	In
26	301	472	519	563	603	663	500	555	605	652	721
31	375	553	603	650	693	760	581	640	694	744	821
36	448	628	680	729	775	846	657	718	774	828	910
40	518	702	756	807	855	930	732	794	853	909	996
45	586	774	830	883	933	1012	804	869	930	988	1079
50	659	850	908	963	1015	1097	881	947	1010	1071	1166
57	758	954	1013	1070	1125	1211	984	1053	1119	1182	1282
67	954	1150	1210	1269	1325	1414	1181	1251	1318	1383	1487
77	1110	1310	1373	1433	1491	1585	1342	1414	1484	1551	1660
89	1300	1505	1570	1632	1693	1792	1537	1612	1684	1754	1868
100	1490	1700	1766	1831	1893	1995	1732	1808	1883	1956	2073

18-in. Beams		Y3 = 5 in.					Y3 = 6 in.				
Reinforcing Bars Area of Reinf., In. <sup>2</sup>		6-#4 1.2	8-#4 1.6	10-#4 2.0	12-#4 2.4	10-#5 3.1	6-#4 1.2	8-#4 1.6	10-#4 2.0	12-#4 2.4	10-#5 3.1
Wt of stl	Is	In	In	In	In	In	In	In	In	In	In
35	510	716	776	831	883	964	747	815	879	939	1032
40	612	824	886	945	1000	1086	855	927	994	1058	1156
46	712	929	994	1055	1113	1204	961	1035	1106	1172	1277
50	800	1017	1083	1145	1204	1297	1049	1124	1196	1264	1371
55	890	1111	1178	1242	1303	1400	1143	1220	1293	1364	1475
60	984	1208	1276	1342	1405	1505	1241	1319	1395	1467	1582
65	1070	1297	1367	1434	1498	1601	1330	1410	1487	1561	1679
71	1170	1400	1471	1540	1606	1712	1433	1515	1593	1669	1791
76	1330	1557	1627	1695	1761	1867	1590	1671	1749	1824	1946
86	1530	1761	1833	1903	1972	2082	1795	1877	1958	2036	2162
97	1750	1985	2060	2132	2202	2316	2019	2104	2187	2268	2398
106	1910	2148	2224	2298	2370	2487	2183	2269	2354	2436	2570
119	2190	2433	2511	2587	2661	2782	2468	2557	2644	2729	2867
130	2460	2709	2788	2866	2943	3068	2744	2835	2924	3011	3154



**Table 7c.  
Negative Bending Moments of Inertia (W21 and W24)**

21-in. Beams		Y3=3 in.					Y3=4in.				
Reinforcing Bars Area of Reinf., In. <sup>2</sup>		6-#4 1.2	8-#4 1.6	10-#4 2.0	12-#4 2.4	10-#5 3.1	6-#4 1.2	8-#4 1.6	10-#4 2.0	12-#4 2.4	10-#5 3.1
Wt of stl	Is	In	In	In	In	In	In	In	In	In	In
44	843	1038	1096	1151	1203	1284	1069	1136	1199	1259	1353
50	984	1184	1244	1301	1355	1441	1215	1284	1350	1413	1512
57	1170	1375	1437	1497	1554	1645	1406	1478	1547	1613	1717
62	1330	1535	1598	1658	1716	1809	1567	1639	1709	1776	1882
68	1480	1688	1753	1815	1874	1970	1720	1794	1866	1935	2045
73	1600	1811	1876	1939	2001	2098	1843	1918	1991	2061	2174
83	1830	2045	2112	2178	2241	2343	2078	2155	2230	2303	2420
93	2070	2289	2358	2425	2491	2596	2322	2402	2479	2554	2675
101	2420	2636	2704	2771	2836	2941	2669	2747	2824	2899	3020
111	2670	2889	2959	3027	3093	3201	2922	3002	3080	3157	3281
122	2960	3182	3253	3323	3391	3502	3216	3297	3377	3455	3583
132	3220	3445	3518	3588	3658	3771	3479	3562	3643	3723	3853
147	3630	3860	3934	4006	4078	4194	3894	3979	4062	4144	4278
166	4280	4517	4594	4670	4744	4866	4552	4640	4726	4811	4951

24-in. Beams		Y3=3in.					Y3=4in.				
Reinforcing Bars Area of Reinf., In. <sup>2</sup>		6-#4 1.2	8-#4 1.6	10-#4 2.0	12-#4 2.4	10-#5 3.1	6-#4 1.2	8-#4 1.6	10-#4 2.0	12-#4 2.4	10-#5 3.1
Wt of stl	Is	In	In	In	In	In	In	In	In	In	In
55	1350	1594	1668	1739	1807	1914	1628	1713	1794	1871	1993
62	1550	1799	1875	1948	2019	2131	1834	1920	2004	2084	2212
68	1830	2080	2157	2232	2304	2418	2115	2203	2288	2370	2500
76	2100	2355	2434	2511	2585	2704	2390	2480	2568	2652	2788
84	2370	2629	2710	2789	2865	2988	2665	2757	2847	2933	3073
94	2700	2964	3047	3128	3207	3335	3000	3095	3187	3276	3421
103	3000	3269	3354	3437	3518	3650	3305	3402	3496	3588	3737
104	3100	3361	3443	3524	3603	3730	3397	3491	3582	3672	3817
117	3540	3805	3890	3973	4054	4185	3842	3938	4032	4124	4273
131	4020	4290	4377	4462	4545	4680	4327	4425	4521	4616	4770
146	4580	4856	4944	5031	5117	5257	4893	4993	5092	5189	5348
162	5170	5451	5542	5631	5719	5863	5489	5591	5693	5792	5955
176	5680	5966	6059	6150	6240	6387	6004	6109	6212	6314	6480
192	6260	6551	6645	6738	6830	6981	6589	6696	6801	6905	7075

**Table 7c. (cont.)  
Negative Bending Moments of Inertia (W21 and W24)**

21-in Beams		Y3=5 in.					Y3=6in.				
Reinforcing Bars Area of Reinf., In. <sup>2</sup>		6-#4 1.2	8-#4 1.6	10-#4 2.0	12-#4 2.4	10-#5 3.1	6-#4 1.2	8-#4 1.6	10-#4 2.0	12-#4 2.4	10-#5 3.1
Wt of stl	Is	In	In	In	In	In	In	In	In	In	In
44	843	1101	1178	1250	1319	1427	1136	1223	1305	1383	1505
50	984	1248	1327	1402	1474	1587	1283	1373	1458	1540	1668
57	1170	1440	1522	1601	1676	1795	1476	1569	1658	1743	1879
62	1330	1600	1683	1763	1839	1961	1636	1730	1821	1907	2045
68	1480	1754	1839	1920	1999	2125	1791	1887	1979	2068	2210
73	1600	1877	1963	2046	2127	2255	1914	2011	2105	2196	2342
83	1830	2112	2201	2286	2369	2503	2149	2249	2346	2440	2592
93	2070	2357	2448	2536	2621	2760	2395	2497	2597	2693	2850
101	2420	2704	2793	2881	2966	3104	2741	2842	2941	3038	3194
111	2670	2957	3049	3138	3225	3367	2995	3098	3199	3298	3458
122	2960	3251	3344	3435	3524	3670	3289	3394	3497	3598	3762
132	3220	3515	3609	3702	3792	3941	3553	3660	3764	3867	4034
147	3630	3930	4026	4121	4214	4367	3969	4077	4184	4289	4461
166	4280	4589	4689	4787	4883	5042	4628	4740	4851	4960	5138

24-in Beams		Y3=5in.					Y3= 6 in.				
Reinforcing Bars Area of Reinf., In. <sup>2</sup>		6-#4 1.2	8-#4 1.6	10-#4 2.0	12-#4 2.4	10-#5 3.1	6-#4 1.2	8-#4 1.6	10-#4 2.0	12-#4 2.4	10-#5 3.1
Wt of stl	Is	In	In	In	In	In	In	In	In	In	In
55	1350	1665	1760	1852	1939	2077	1703	1811	1913	2011	2166
62	1550	1870	1969	2063	2153	2298	1910	2020	2125	2227	2389
68	1830	2152	2252	2347	2440	2587	2191	2303	2411	2514	2680
76	2100	2428	2530	2628	2724	2877	2467	2582	2692	2799	2971
84	2370	2703	2807	2908	3006	3164	2743	2860	2973	3083	3260
94	2700	3038	3145	3249	3350	3513	3079	3199	3315	3428	3611
103	3000	3344	3453	3559	3663	3831	3385	3507	3626	3742	3930
104	3100	3435	3541	3644	3745	3909	3475	3594	3710	3823	4007
117	3540	3880	3989	4095	4198	4367	3921	4043	4161	4277	4466
131	4020	4366	4477	4585	4691	4865	4407	4531	4653	4772	4966
146	4580	4932	5045	5157	5266	5445	4974	5101	5225	5347	5547
162	5170	5528	5644	5758	5870	6053	5571	5700	5827	5952	6157
176	5680	6044	6162	6278	6392	6580	6087	6218	6348	6475	6685
192	6260	6630	6749	6867	6984	7176	6672	6806	6938	7068	7282

**Table 8.**  
**Details of Prequalified Connections**  
**Unbraced  $F_y = 36$  ksi**

Connection							Bolt Shear			
Rein.	Neg For (k)	Pos For (k)	horz-leg (in.)	vert-leg (in.)	$t$ (in.)	$L$ (in.)	$V_u/bolt$ (k)	$d$ (in.)	Type	Shear (k)
6 #4	90.0	30.4	6	4	0.3125	8	22.5	0.75	3X/4N	24.9
	90.0	30.4	6	4	0.3125	8	22.5	0.875	325N	27.0
8 #4	118.1	39.9	6	4	0.4375	7.5	29.531	0.875	3X/4N	33.9
	118.1	39.9	6	4	0.4375	7.5	29.531	1	325N	35.4
10 #4	144.0	48.6	6	4	0.5	8	36	0.875	490X	42.4
	144.0	48.6	6	4	0.5	8	36	1	3X/4N	44.1
12 #4	180.0	60.8	6	4	0.625	8	45	1	490X	55.3
10 #5	220.5	74.4	6	4	0.875	7	55.125	1	490X	55.3

Notes:

- (1) Four bolts are used for the bottom angle to beam connection.
- (2) The design shear strength of the bolts is the 1994 LRFD Table 8-11 values divided by 0.8.
- (3) 3X/4N denotes that either A325X or A490N high strength bolts may be used.
- (4) Values of bolt shear are the design values.

Bearing on Angle							Tension Yield and Rupture				
Rein.	$L_e$ (in.)	$S$ (in.)	Rq. spac (Y/N)	$R_u(int)$ (k)	$R_u(ext)$ (k)	Sum $R_u$	$A_g$ (in. <sup>2</sup> )	$A_n$ (in. <sup>2</sup> )	$A_n/A_g$	Yield	Rupture
						Neg forc				Pos forc	Pos forc
6 #4	2.25	2.5	Y	24.5	24.5	1.09	2.50	1.99	0.80	2.67	2.85
	2.25	2.5	N	28.0	28.5	1.26	2.50	1.91	0.77	2.67	2.74
8 #4	2.25	2.5	N	39.3	40.0	1.34	3.28	2.46	0.75	2.67	2.69
	2.25	2.5	N	38.1	42.8	1.37	3.28	2.35	0.72	2.67	2.57
10 #4	2.25	2.5	N	44.9	45.7	1.26	4.00	3.06	0.77	2.67	2.74
	2.25	2.5	N	43.5	48.9	1.28	4.00	2.94	0.73	2.67	2.63
12 #4	2.25	2.5	N	54.4	61.2	1.28	5.00	3.67	0.73	2.67	2.63
10 #5	2.25	2.5	N	76.1	85.6	1.47	6.13	4.27	0.70	2.67	2.49

Notes:

- (1) Y/N denotes whether the required bolt spacing of 3db and edge spacing of 1.5db is met.
- (2) The critical values to be checked are expressed as the provided over the required value. If this ratio is greater than 1 then the check passes.
- (3) 3X/4N denotes that either A325X or A490N high strength bolts may be used.

Prying Action											
Conn & Bolts	$R_{ut}$ (k)	$R_u$ (k)	$b$ (in.)	$a$ (in.)	$b'$ (in.)	$a'$ (in.)	$\delta$	$t_c$ (in.)	$\alpha$	$q_u$ (k)	$R_{ut} + q_u$
											Pos forc
3/4-in. 3X 3/4-in. 4N 7/8-in. 3N	15.2	29.8	2.19	1.81	1.81	2.19	0.80	1.29	9.65	11.1	1.13
	15.2	37.4	2.19	1.81	1.81	2.19	0.80	1.45	9.65	11.1	1.42
	15.2	40.6	2.19	1.81	1.75	2.25	0.77	1.48	9.65	10.4	1.59
7/8-in. 3X 7/8-in. 4N 1 in. 3N	19.9	40.6	2.06	1.94	1.63	2.38	0.75	1.47	6.09	11.2	1.30
	19.9	51.0	2.06	1.94	1.63	2.38	0.75	1.65	6.09	11.2	1.64
	19.9	53.0	2.06	1.94	1.56	2.44	0.72	1.65	6.07	10.4	1.75
7/8-in. 4X 1 in. 3X 1 in. 4N	24.3	51.0	2.00	2.00	1.56	2.44	0.77	1.57	4.81	12.3	1.39
	24.3	53.0	2.00	2.00	1.50	2.50	0.73	1.57	4.76	11.3	1.49
	24.3	66.6	2.00	2.00	1.50	2.50	0.73	1.76	4.76	11.3	1.87
1 in. 4X	30.4	66.6	1.88	2.13	1.38	2.63	0.73	1.68	3.13	11.1	1.61
1 in. 4X	37.2	66.6	1.63	2.03	1.13	2.53	0.70	1.62	1.33	8.0	1.47

Notes:

- (1) The critical values to be checked are expressed as the provided over the required value. If this ratio is greater than 1 then the check passes.
- (2) The gage for the vertical connection leg is 2.5 inches.
- (3) The tributary bearing length for prying,  $p$ , is  $L/2$ .
- (4) The value "a" in prying action for 10 #5 was taken as the maximum value = 1.25b.
- (5) 3X/4N denotes that either A325X or A490N high strength bolts may be used.

**Table 8. (cont.)  
Details of Prequalified Connections  
Braced  $F_y = 36$  ksi**

Connection						Bolt Shear			
Rein.	Neg For (k)	horz-leg (in.)	vert-leg (in.)	$t$ (in.)	$L$ (in.)	$V_u/bolt$ (k)	$d$ (in.)	Type	$V_u$ (k)
6 #4	78.8	6	4	0.3125	7	19.7	0.75	325N	19.9
8 #4	101.3	6	4	0.375	7.5	25.3	0.875	325N	27.0
10 #4	126.0	6	4	0.5	7	31.5	1	325N	35.4
	126.0	6	4	0.5	7	31.5	0.875	3X/4N	33.9
12 #4	144.0	6	4	0.5	8	36.0	1	490N	44.1
	144.0	6	4	0.5	8	36.0	0.875	490X	42.4
10 #5	189.0	6	4	0.75	7	47.3	1	490X	55.3

**Bearing on Angle**

Rein.	$L_e$ (in.)	$S$ (in.)	Rq. spac (Y/N)	$R_u(Int)$ (k)	$R_u(ext)$ (k)	Sum $R_n$
						Neg forc
6 #4	2.25	2.5	Y	24.5	24.5	1.24
8 #4	2.25	2.5	N	33.6	34.2	1.34
10 #4	2.25	2.5	N	43.5	48.9	1.47
	2.25	2.5	N	44.9	45.7	1.44
12 #4	2.25	2.5	N	43.5	48.9	1.28
	2.25	2.5	N	44.9	45.7	1.26
10 #5	2.25	2.5	N	65.3	73.4	1.47

Notes:

- (1) These are the minimum angle and bolt sizes that are acceptable by capacity design.
- (2) The bearing on angle check is expressed as the provided over the required value. If this ratio is greater than 1 then the check passes.
- (3) The design shear strength of the bolts is the 1994 LRFD Table 8-11 value divided by 0.8.
- (4) 3X/4N denotes that either A325X or A490N high strength bolts may be used.

**Table 8. (cont.)  
Details of Prequalified Connections  
Unbraced  $F_y = 50$  ksi**

Connection							Bolt Shear			
Rein.	Neg For (k)	Pos For (k)	horz-leg (in.)	vert-leg (in.)	t (in.)	L (in.)	Vu/bolt (k)	d (in.)	Type	Shear (k)
6 #4	93.8	31.6	6	4	0.3125	6	23.44	0.75	3X/4N	24.9
	93.8	31.6	6	4	0.3125	6	23.44	0.875	325N	27.0
8 #4	117.2	39.6	6	4	0.3125	7.5	29.30	0.875	3X/4N	33.9
	117.2	39.6	6	4	0.3125	7.5	29.30	1	325N	35.4
10 #4	150.0	50.6	6	4	0.375	8	37.5	0.875	490X	42.4
	150.0	50.6	6	4	0.375	8	37.5	1	3X/4N	44.1
12 #4	175.0	59.1	6	4	0.5	7	43.75	1	3X/4N	44.1
10 #5	225.0	75.9	6	4	0.5625	8	37.5*	1	3X/4N	44.1

Notes:

\*6 bolts must be used for 10 #5

- (1) Four bolts are used for the bottom angle to beam flange connection except for 10 #5.
- (2) The design shear strength of the bolts is the 1994 LRFD Table 8-11 values divided by 0.8.
- (3) 3X/4N denotes that either A325X or A490N high strength bolts may be used.

Connection		Bearing on Angle					Tension Yield and Rupture					
Rein.	Bolts	Le (in.)	S (in.)	Rq. spac (Y/N)	Ru(int) (k)	Ru(ext) (k)	Sum Ru	Ag (in. <sup>2</sup> )	An (in. <sup>2</sup> )	An/Ag	Yield	Rupture
							Neg forc				Pos forc	Pos forc
6 #4	3X/4N	2.25	2.5	Y	27.4	27.4	1.17	1.88	1.37	0.73	2.67	2.11
	325N	2.25	2.5	N	31.4	32.0	1.35	1.88	1.29	0.69	2.67	1.99
8 #4	3X/4N	2.25	2.5	N	31.4	32.0	1.08	2.34	1.76	0.75	2.67	2.17
	325N	2.25	2.5	N	30.5	34.3	1.11	2.34	1.68	0.72	2.67	2.07
10 #4	490X	2.25	2.5	N	37.7	38.4	1.01	3.00	2.30	0.77	2.67	2.21
	3X/4N	2.25	2.5	N	36.6	41.1	1.04	3.00	2.20	0.73	2.67	2.12
12 #4	3X/4N	2.25	2.5	N	48.8	54.8	1.18	3.50	2.44	0.70	2.67	2.01
10 #5	3X/4N	2.25	2.5	N	54.8	61.7	1.04	4.50	3.30	0.73	2.67	2.12

Notes:

- (1) Y/N denotes whether the required bolt spacing of 3db and edge spacing of 1.5db is met.
- (2) The critical values to be checked are expressed as the provided over the required value. If this ratio is greater than 1 then the check passes.
- (3) 3X/4N denotes that either A325X or A490N high strength bolts may be used.

Connection		Prying Action										
Rein.	Bolts	Rut (k)	Ru (k)	b (in.)	a (in.)	b' (in.)	a' (in.)	$\delta$	tc (in.)	$\alpha$	qu (k)	Rut + qu
												Pos forc
6 #4	3/4-in. 3X	15.8	29.8	2.19	1.81	1.81	2.19	0.73	1.26	10.55	11.6	1.09
	3/4-in. 4N	15.8	37.4	2.19	1.81	1.81	2.19	0.73	1.42	10.55	11.6	1.37
	7/8-in. 3N	15.8	40.6	2.19	1.81	1.75	2.25	0.69	1.45	10.75	10.8	1.52
8 #4	7/8-in. 3X	19.8	40.6	2.19	1.81	1.75	2.25	0.75	1.30	9.86	13.5	1.22
	7/8-in. 4N	19.8	51.0	2.19	1.81	1.75	2.25	0.75	1.45	9.86	13.5	1.53
	1 in. 3N	19.8	53.0	2.19	1.81	1.69	2.31	0.72	1.46	9.90	12.6	1.64
10 #4	7/8-in. 4X	25.3	51.0	2.13	1.88	1.69	2.31	0.77	1.38	7.50	15.7	1.24
	1 in. 3X	25.3	53.0	2.13	1.88	1.63	2.38	0.73	1.38	7.48	14.7	1.33
	1 in. 4N	25.3	66.6	2.13	1.88	1.63	2.38	0.73	1.55	7.48	14.7	1.67
12 #4	1 in. 4X	29.5	66.6	2.00	2.00	1.50	2.50	0.70	1.59	5.02	13.8	1.54
10 #5	1 in. 4X	38.0	66.6	1.94	2.06	1.44	2.56	0.73	1.46	3.85	15.7	1.24

Notes:

- (1) The critical values to be checked are expressed as the provided over the required value. If this ratio is greater than 1 then the check passes.
- (2) The gage for the vertical connection leg is 2.5 inches.
- (3) The tributary bearing length for prying,  $p$ , is  $L/2$ .
- (4) 3X/4N denotes that either A325X or A490N high strength bolts may be used.

**Table 8. (cont.)  
Details of Prequalified Connections  
Braced  $F_y= 50$  ksi**

Connection						Bolt Shear			
Rein.	Neg For (k)	horz-leg (in.)	vert-leg (in.)	$t$ (in.)	$L$ (in.)	$V_u/bolt$ (k)	$d$ (in.)	Type	$V_u$ (k)
6 #4	72.0	6	4	0.3125	5	18.0	0.75	325N	19.9
8 #4	101.6	6	4	0.3125	6.5	25.4	0.875	325N	27.0
10 #4	125.0	6	4	0.3125	8	31.3	1	325N	35.4
	125.0	6	4	0.3125	8	31.3	0.875	3X/4N	33.9
12 #4	150.0	6	4	0.375	8	37.5	1	3X/4N	44.1
	150.0	6	4	0.375	8	37.5	0.875	490X	42.4
10 #5	175.0	6	4	0.5	7	43.8	1	3X/4N	44.1

**Bearing on Angle**

Rein.	$L_e$ (in.)	$S$ (in.)	Rq. spac (Y/N)	$R_u(int)$ (k)	$R_u(ext)$ (k)	Sum $R_n$
						Neg forc
6 #4	2.25	2.5	Y	27.4	27.4	1.52
8 #4	2.25	2.5	N	31.4	32.0	1.25
10 #4	2.25	2.5	N	30.5	34.3	1.04
	2.25	2.5	N	31.4	32.0	1.01
12 #4	2.25	2.5	N	36.6	41.1	1.04
	2.25	2.5	N	37.7	38.4	1.01
10 #5	2.25	2.5	N	48.8	54.8	1.18

Notes:

- (1) These are the minimum angle and bolt sizes that are acceptable by capacity design.
- (2) The bearing on angle check is expressed as the provided over the required value. If this ratio is greater than 1 then the check passes.
- (3) The design shear strength of the bolts is the 1994 LRFD Table 8-11 value divided by 0.8.
- (4) 3X/4N denotes that either A325X or A490N high strength bolts may be used.

# Appendix A

## STORY SWAY CALCULATIONS

With the assumption that the inflection points of the girders and columns are at midlength and midheight (assumptions made in a portal analysis, see Figure 6) the total interstory drift of story  $i$  due to column and beam flexure and rotation of the connections can be shown to be:

$$\Delta_{total} = V_i h_i^2 \left( \frac{1}{\Sigma K_c} + \frac{1}{\Sigma K_g} + \frac{1}{\Sigma K_{conn}} \right) \quad (A-1)$$

$$\Sigma K_c = \Sigma \frac{12EI_c}{h_i} = \text{story column stiffness} \quad (A-2)$$

$$\Sigma K_g = \Sigma \frac{12EI_g}{L} = \text{story girder stiffness} \quad (A-3)$$

$$\Sigma K_{conn} = \text{story connection stiffness} \quad (A-4)$$

where

- $I_{eq}$  = the equivalent girder inertias
- $I_c$  = the column inertias
- $L$  = the girder lengths
- $h_i$  = the height of story  $i$ , and
- $V_i$  = the shear at story  $i$ .

By letting:

$$\Delta_{column} = \Delta_{girder} = \Delta_{connection} = 1/3 \Delta_{total}$$

a well proportioned preliminary structure can easily be sized, where  $\Delta_{total}$  is the design interstory drift (e.g.,  $H/400$  for wind loads).

We can determine either the sum or average moment of inertia for the columns in story  $i$  by:

$$\Sigma I_c = N_c I_{c(ave)} = \frac{V_i h_i^3}{4E\Delta_{total}} \quad (A-5)$$

where

$$N_c = \text{the number of columns in a story.}$$

Similarly, the connection stiffness at story  $i$  is given by:

$$\Sigma K_{conn} = N_{conn} K_{conn(ave)} = \frac{3V_i h_i^2}{\Delta_{total}} \quad (A-6)$$

where

$$N_{conn} = \text{the number of connections for story } i.$$

When determining the girder moment of inertia two different equations can be used depending on whether all bays in the story are the same length. If all the bays are the same length then:

$$\Sigma I_{eq} = N_g I_{eq(ave)} = \frac{LV_i h_i^2}{4E\Delta_{total}} \quad (A-7)$$

If all the bays are not the same length, where  $N_{g1}$  have length  $L_1$ , and  $N_{g2}$  have length  $L_2$ , and  $I_{eq2}/I_{eq1} = C_I$ , then:

$$I_{eq1} = \frac{L_1 L_2}{(N_{g1} L_2 + N_{g2} C_I L_1)} \frac{V_i h_i^2}{4E\Delta_{total}} \quad (A-8)$$

Note that when the exterior connections are pinned the exterior columns are effectively gravity columns and cannot be included in the number of drift resisting columns. Also, the exterior girders are in single curvature instead of double curvature, as the interstory drift equation is based on. Therefore, only  $1/2$  of the exterior girders, or one total, should be used in this calculation.

When considering the base columns to be fixed, Equation (A-1) overestimates the first level interstory drift. Again this is because the equation is based on columns and girders in double curvature with inflection points at mid-height and mid-length. It is suggested to calculate the 1st story values using 90 percent of the story height. If this gives smaller required values then the 2nd story then the 1st story should be designed for the 2nd story values.

used for lateral drift analysis,  $K_{lat}$  is not the same as the gravity connection stiffness,  $K_{grav}$ .

# NOTATION

$A_s$	= steel reinforcing area	$M_n^+$	= connection nominal moment capacity (positive bending; from Equation 2)
$A_l$	= area of bottom angle	$M_n^-$	= connection nominal moment capacity (negative bending; from Equation 1)
$A_{wi}$	= gross area of double web angles for shear calculations	$Y3$	= distance from the top flange of the girder to the centroid of the reinforcement, in
$DL_A$	= dead loads applied after the slab hardens	$d$	= girder depth, in
$DL_B$	= dead loads applied before the slab hardens	$\phi M_{n,conn}$	= connection design capacity (from Table 1, Part IV or Eq. 6 with $\phi = 0.85$ )
$I_{LB(ss)}$	= lower bound moment of inertia required for simply-supported composite beam	$\phi M_{n,comp}$	= beam design capacity in positive bending $\phi = 0.85$
$I_{LB(PR)}$	= lower bound moment of inertia required for PR composite beam	$\phi M_{n,PNA=1}$	= capacity of composite beam with PNA = 1 (full interaction)
$I_{eq}$	= equivalent moment of inertia for composite beam (Equations (24) and (25), Part I)	$\phi M_{p,bare}$	= plastic design capacity of the steel beam
$I_{LB(+)}$	= lower bound moment of inertia ( $I_{LB}$ ) from LRFD Manual (positive moment)	$\phi M_{n,PNA=7}$	= plastic capacity of composite beam with PNA = 7 (25% interaction)
$I_n$	= lower bound moment of inertia (negative moment; from Table 7, Part IV)	$\delta_{sr}$	= live load deflection limit
$F_{yrb}$	= yield stress of reinforcing, ksi	$\delta_{ff}$	= deflection of the beam as a fixed-fixed system
$F_y$	= yield stress of seat and web angles, ksi	$\theta_{sym}$	= end rotation for PR beam with equal connections at either end
$L$	= beam or girder span	$\theta$	= rotation (radians)
$LL$	= live loads		
$M$	= moment		
$M_u$	= design strength		
$M_{u,cons}$	= design capacity for the "construction beam"		





**DESIGN GUIDE SERIES**  
**American Institute of Steel Construction, Inc.**  
**One East Wacker Drive, Suite 3100**  
**Chicago, Illinois 60601-2001**